

**INSTALLATION DETAIL**  
ALL DIMENSIONS TYPICAL  
EACH SIDE OF CONVEYOR  
ON ALL LAYOUTS

ITEM	QTY.	DESCRIPTION	PART NUMBER
1	*	HD DOUBLE APRON SEAL™	100861
2	**	HEAVY DUTY ANGLE CLAMP WELDMENT	34339
3	***	STUD 5/8-11NC X 4 ZP	34398
4	***	NUT FLANGE LOCKING 5/8-11NC ZP	34399
5	***	WASHER FLAT 5/8 ZP	16814
6	***	NUT HEX FLANGE 5/8-11NC PLAIN	38659

- \* - CUT TO LENGTH (SPECIFY LENGTH NEEDED IN FEET).
- \*\* - EACH WELDMENT IS 71.88 [1826] LONG. (1) WELDMENT REQUIRED PER EVERY 6'-0" [1829] OF HD DOUBLE APRON SEAL.
- \*\*\* - QTY. 1 EACH OF P/N 34398, 34399, 16814 & 38659 ARE SUPPLIED PER EACH FOOT OF HD APRON SEAL. P/N 34399 IS USED TO HOLD THE ANGLE CLAMP IN PLACE ON THE STUD. P/N 38659 IS WELDED TO THE CHUTE WALL AND THEN STUD IS INSERTED.

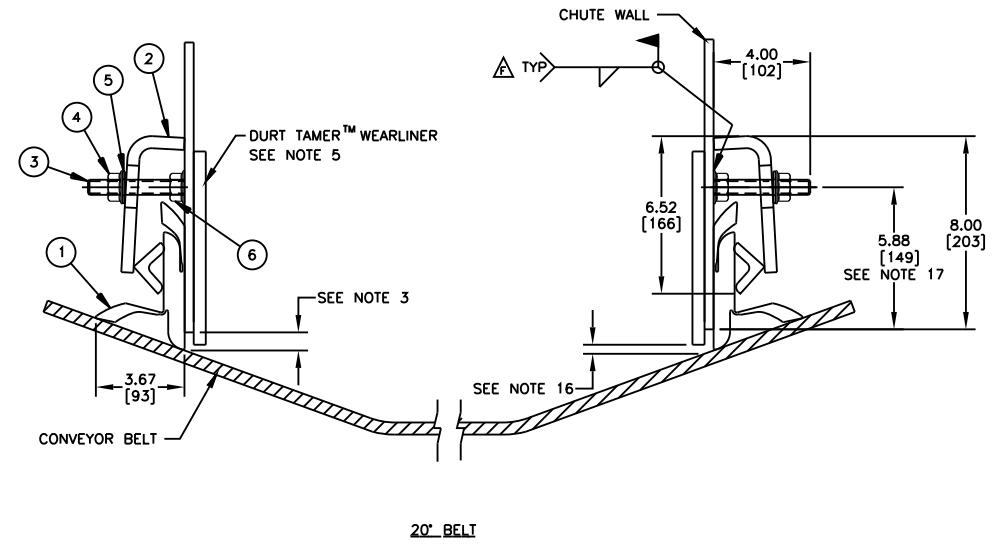
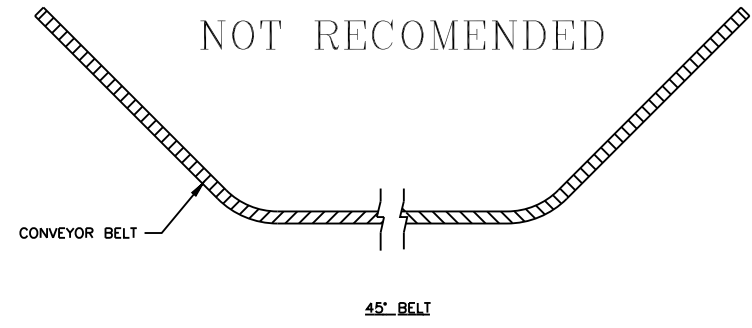

- NOTES:
- 1) ALL DIMENSIONS ARE GIVEN IN INCHES (MM).
  - 2) ALL DIMENSIONS ARE FOR REFERENCE ONLY.
  - 3) MARTIN ENGINEERING RECOMMENDS CHUTE WALL TO BE WITHIN .75 (19) OF BELT.
  - 4) A MIN. OF 8.00 (203) VERTICAL AND 5.00 (127) HORIZONTAL CLEARANCE REQUIRED TO INSTALL APRON SEAL™ & ANGLE CLAMPS.
  - 5) TO PROVIDE AN EFFECTIVE SEAL, DURT TAMER™ WEARLINERS (STRAIGHT OR DEFLECTOR) ARE RECOMMENDED TO PREVENT THE MAIN LOAD FROM CONTACTING THE APRON SEAL™ (STRAIGHT WEARLINER SHOWN).
  - 6) IF DURT TAMER™ WEARLINERS ARE BOLTED TO CHUTE WALL, APRON SEAL™ AND ANGLE CLAMPS ARE TO BE MOUNTED IN A MANNER AS TO ALLOW EASY ACCESS TO BOLTS.
  - 7) APRON SEAL™ IS DESIGNED AS A DUST SEAL ONLY. IT IS NOT TO BE USED AS A MATERIAL HOLDBACK OR LOAD CARRYING SURFACE.
  - 8) BELT MUST NOT LIFT OFF IDLERS DURING START-UP OR WHILE BELT IS IN OPERATION.
  - 9) BELT MUST TRACK PROPERLY TO PREVENT IT FROM RUNNING BEHIND APRON SEAL™.
  - 10) CONSULT MARTIN ENGINEERING FOR INSTALLATIONS WITH UNUSUAL OR SEVERE CONDITIONS, I.E.: CONCAVE/CONVEX CURVES, EXTREME SIDE PRESSURE, UNUSUALLY FAST OR SLOW MOVING BELTS, TEMPERATURE EXTREMES, ETC.
  - 11) APRON SEAL™ AND DURT TAMER™ WEARLINER SHOULD BEGIN AT LEAST 12.00 (305) BEFORE INLET SIDE OF CHUTE WALL.
  - 12) CONTACT MARTIN ENGINEERING PRIOR TO MOUNTING THESE PRODUCTS IN ANY WAY OTHER THAN WHAT IS DEPICTED ON THIS DRAWING OR IN OPERATOR'S MANUAL (M3248).
  - 13) ANGLE CLAMP WELDMENT (ITEM 2) IS TO BE FULLY TIGHTENED AGAINST CHUTE WALL.
  - 14) ANGLE CLAMP WELDMENT MUST HAVE FIRM BACKING TO ENSURE PROPER CLAMP FORCE.
  - 15) REFER TO OPERATOR'S MANUAL M3248 DURING INSTALLATION. THIS DRAWING NOT TO BE USED IN PLACE OF OPERATOR'S MANUAL.
  - 16) .38 (10) MAX. IN IMPACT AREA, TAPERING TO .75 (19) AT EXIT AREA.
  - 17) FOR FLAT TO 35° BELTS USE PRE-FAB CHUTE WALL P/N 33564-35.

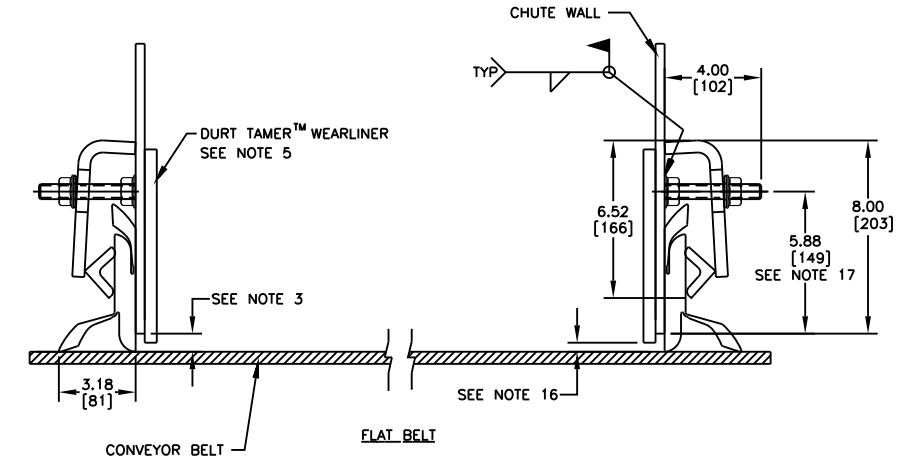
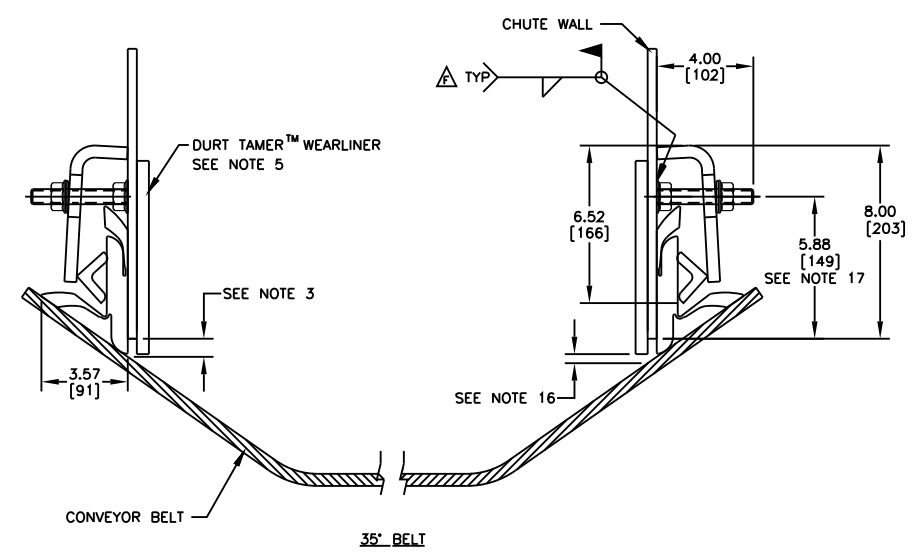

**INSTALLATION INSTRUCTIONS:**

- STEP 1: SCRIBE A LINE ON CHUTE WALL PARALLEL TO BELT SURFACE 6.63 [168] ABOVE BELT.
- STEP 2: ALONG THIS LINE, MAKE FIRST MARK 5.88 [149] FROM END OF CHUTE WALL AND MARK EVERY 12.00 [305] AFTER THAT.
- STEP 3: ON THESE MARKED CENTERS, WELD 5/8-11NC FLANGE NUTS (P/N 38659), THEN INSERT STUDS. MAKE SURE STUDS ARE PERPENDICULAR TO THE CHUTE WALL TO ENSURE EVEN CLAMP CONTACT.
- STEP 4: INSTALL HD APRON SEAL™ AND PLACE AGAINST CHUTE WALL, MAKING SURE THAT HD APRON SEAL™ IS ALSO TOUCHING THE BELT, SLIDE CLAMPS OVER STUDS.
- STEP 5: PUSH HD ANGLE CLAMP WELDMENT TIGHT AGAINST HD APRON SEAL™ AND INSTALL WASHER (P/N 16814) & FLANGE NUT (P/N 34399). TIGHTEN FLANGE NUT TO 40 FT./LBS.

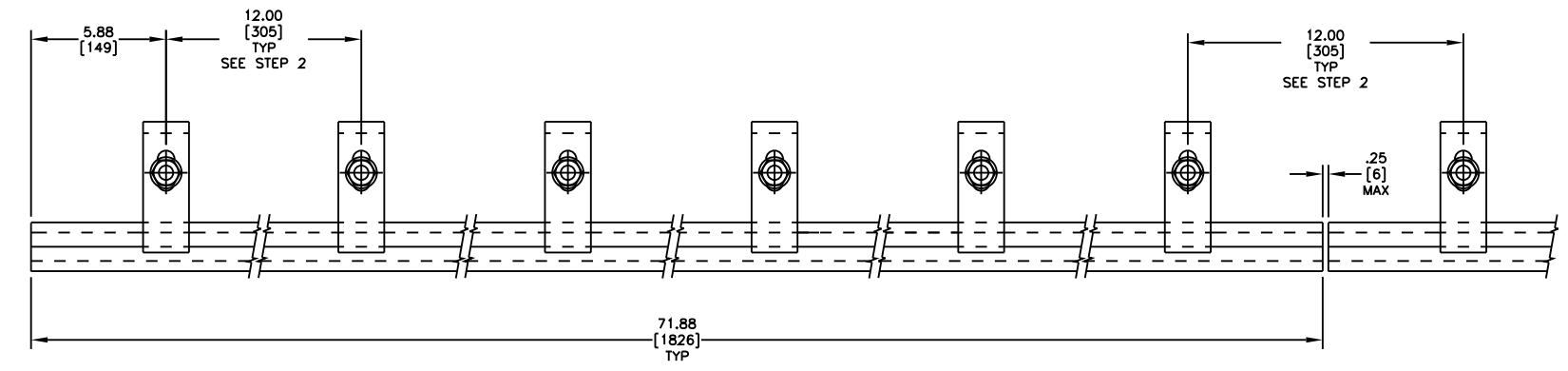

**ANGLE CLAMP DETAIL**

© Copyright 2010 Martin Engineering. All rights reserved. Covered by U.S. and foreign patents pending and issued. ® and ™ indicate trademarks of Martin Engineering.

**MARTIN ENGINEERING** NEPONSET ILLINOIS USA

TITLE	MARTIN® HEAVY DUTY DOUBLE APRON SEAL™ & HEAVY DUTY ANGLE CLAMP INSTALLATION DRAWING	DRAWN RND	DATE 05/13/10
NO.	DESCRIPTION	ECN	DATE
1	ADDED P/N 38659 TO BOM/UPDATED *** NOTE & INSTALLATION INSTRUCTION STEP 3 & 5	14606	07/22/16
SALES DRAWING		BY	MJB
AutoCAD		REVISION	

APPROVED	DATE 05/13/10	SCALE	1/4
M00807		S50065-HDC	

