

Martin® QC1™ Cleaner XHD Replacement Parts List

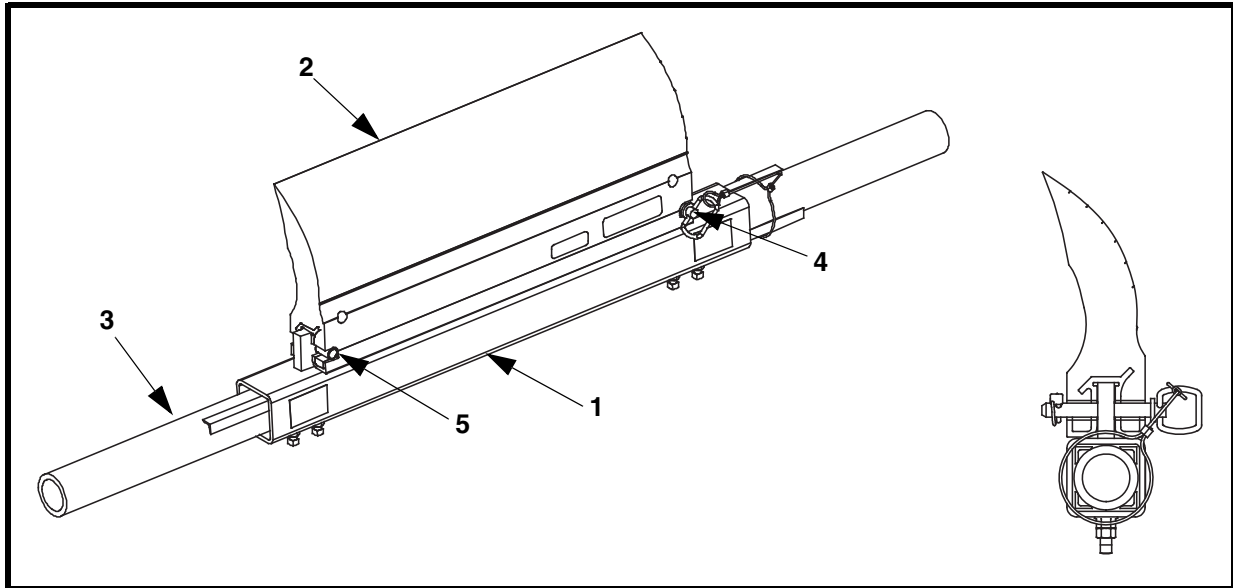

Martin® QC1™ Cleaner XHD Assembly, P/N 35899-XXXXXXXX

Item	Description	Part No.	Qty.
1	Mainframe	36231-XX	1
2	Blade	35897-XXXXXX	1
3	Pipe End Weldment	32332-XX	2
4	Hitch Pin with Lynch Pin	36976	1
5	Knurled Pin	36046	1
—	Mainframe Assembly without Blade	35899-XXA	—

BLADE NOMENCLATURE 35897 - XX XX XX

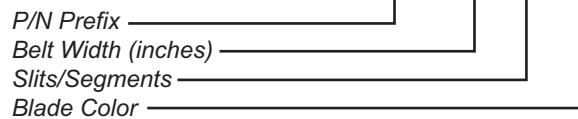

- SLITS/SEGMENTS**
11: No slits or segments
10: Segments only
01: Slits only
00: Slits & Segments

- BLADE COLOR**
BR: Brown
CL: Tan
GR: Green
NB: Navy Blue
Blank: Orange