

PART NO.	BELT WIDTH	DIM "A" MAX FRAME LENGTH	DIM "B" BLADE COVERAGE
35899-48XX42XXX	48.00 [1200-1400]	96.00 [2438]	42.00 [1067]
35899-54XX42XXX	54.00 [1400-1600]	102.00 [2591]	42.00 [1067]
35899-54XX48XXX	54.00 [1400-1600]	102.00 [2591]	48.00 [1219]
35899-60XX48XXX	60.00 [1600-1800]	108.00 [2743]	48.00 [1219]
35899-60XX54XXX	60.00 [1600-1800]	108.00 [2743]	54.00 [1372]
35899-66XX54XXX	66.00 [1700-1800]	114.00 [2896]	54.00 [1372]
35899-66XX60XXX	66.00 [1700-1800]	114.00 [2896]	60.00 [1524]
35899-72XX60XXX	72.00 [1800-2000]	120.00 [3048]	60.00 [1524]
35899-72XX66XXX	72.00 [1800-2000]	120.00 [3048]	66.00 [1676]

MOUNTING LOCATION CHART	
DIM "C" HEAD PULLEY DIAMETER *	DIM "D"
16 [400]	5.75 [146]
20 [500]	5.50 [140]
24 [600]	5.25 [133]
28 [700]	5.00 [127]
30-120 [750-3000]	4.75 [120]

* INCLUDES BELT AND LAGGING

ASSEMBLY PART NO.	COLOR
35899-XXXXXXX	ORANGE
35899-XXXXXXBRX	BROWN
35899-XXXXXXCLX	TAN
35899-XXXXXXGRX	GREEN
35899-XXXXXXNBX	NAVY BLUE
35899-XXXXXXCYX *	YELLOW W/BEADS
35899-XXXXXXYLX *	YELLOW

* ONLY OFFERED IN SEGMENTED (10)

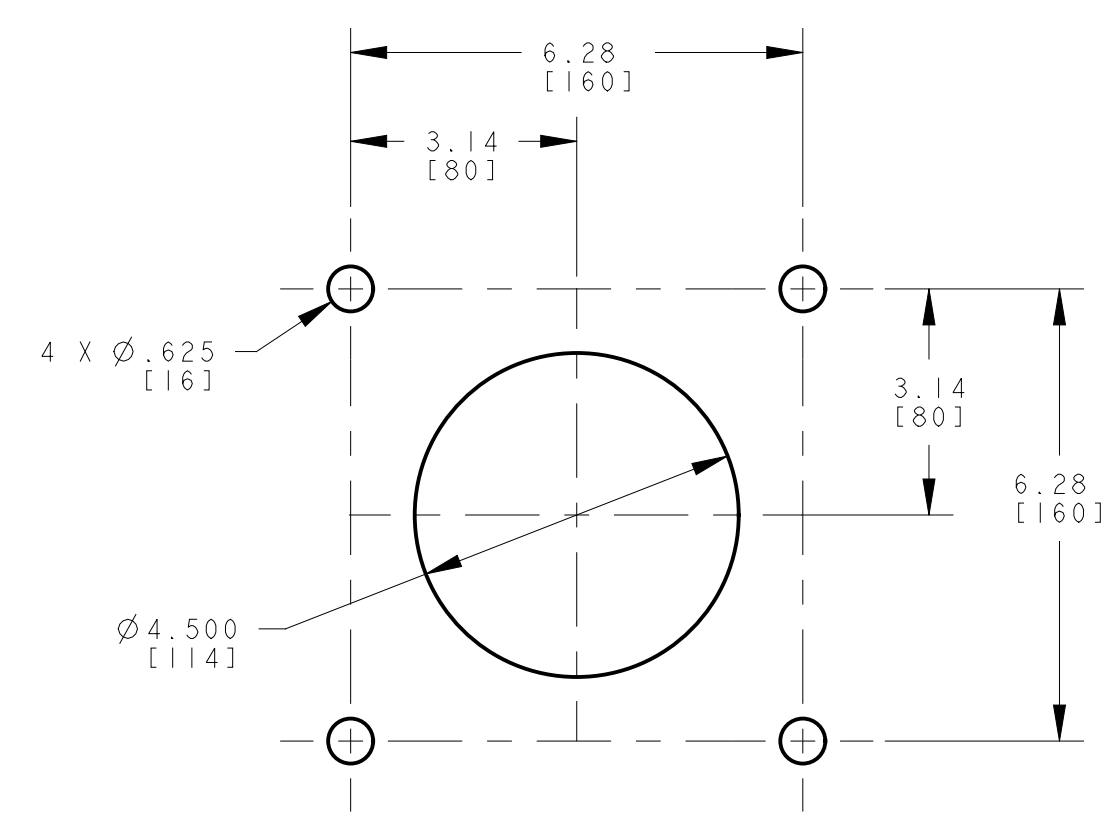
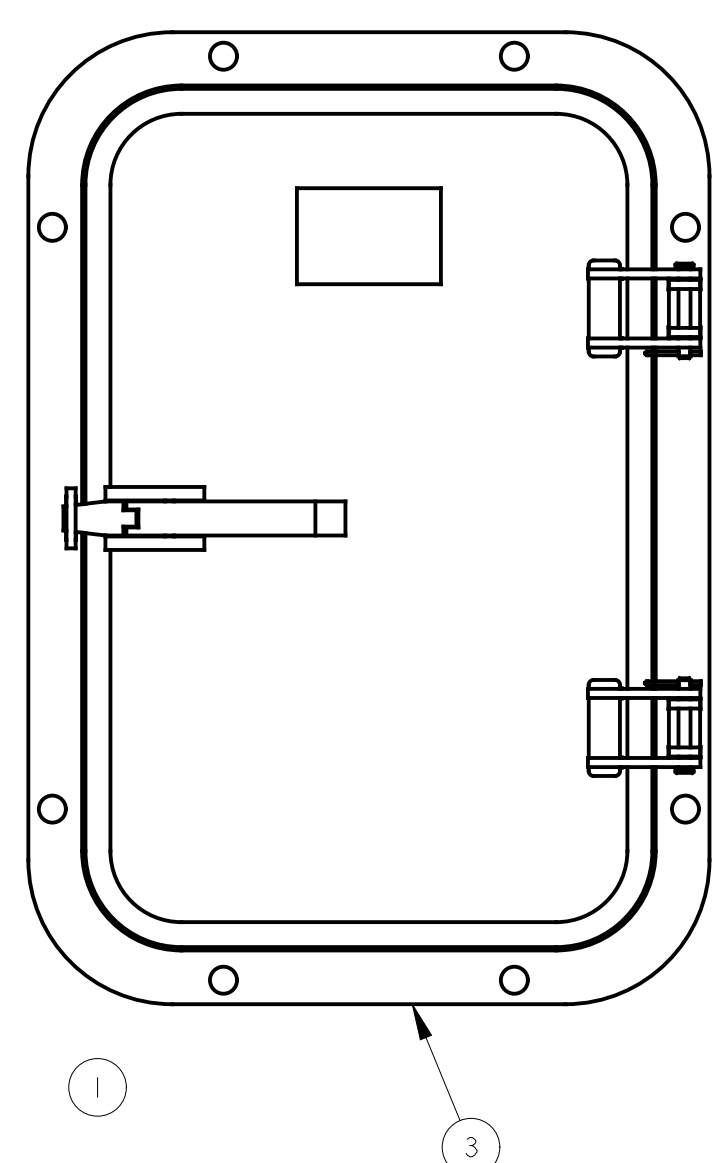
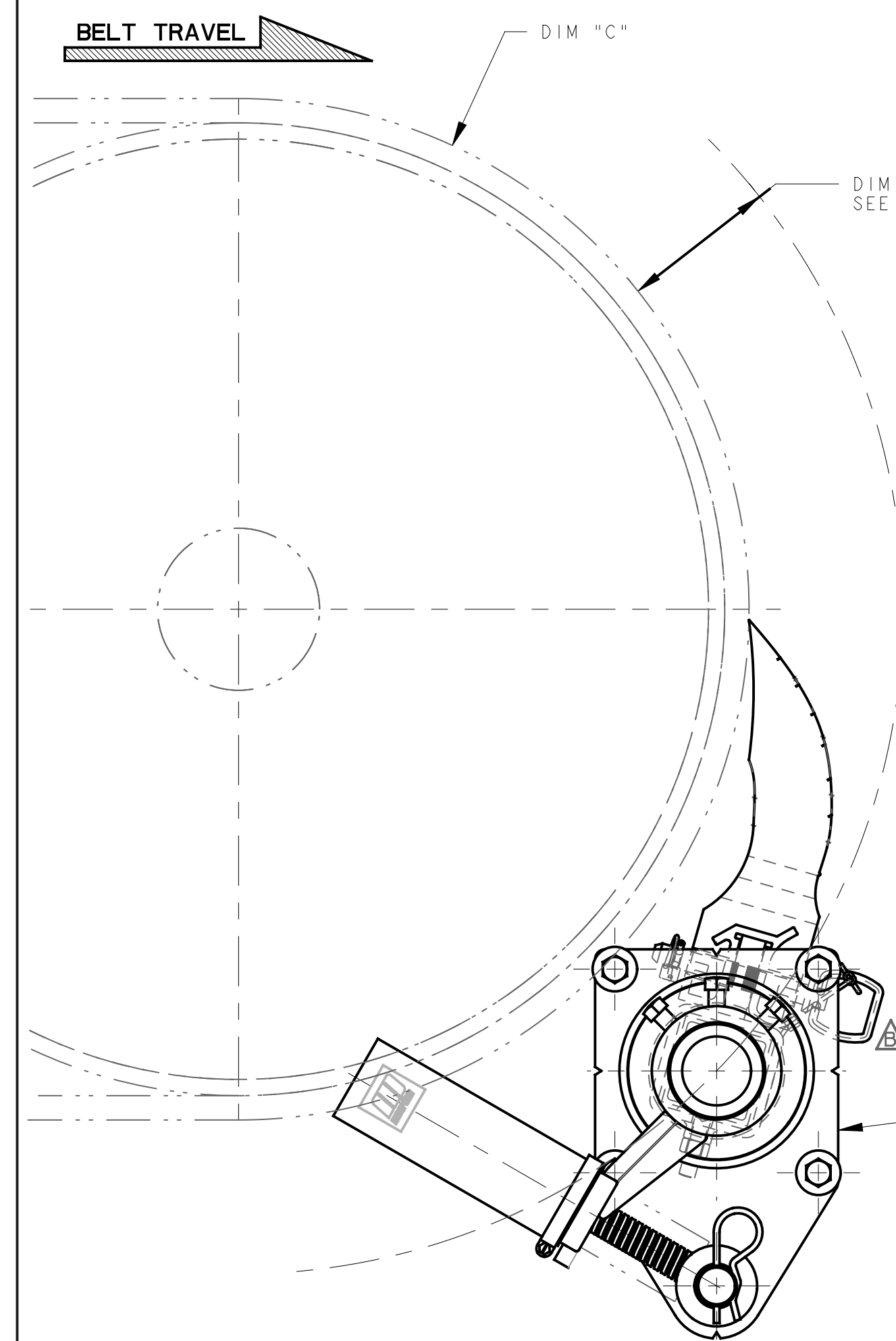

TENSIONER CHUTE CUTOUT DETAIL
SCALE 3/8
TYPICAL BOTH SIDES

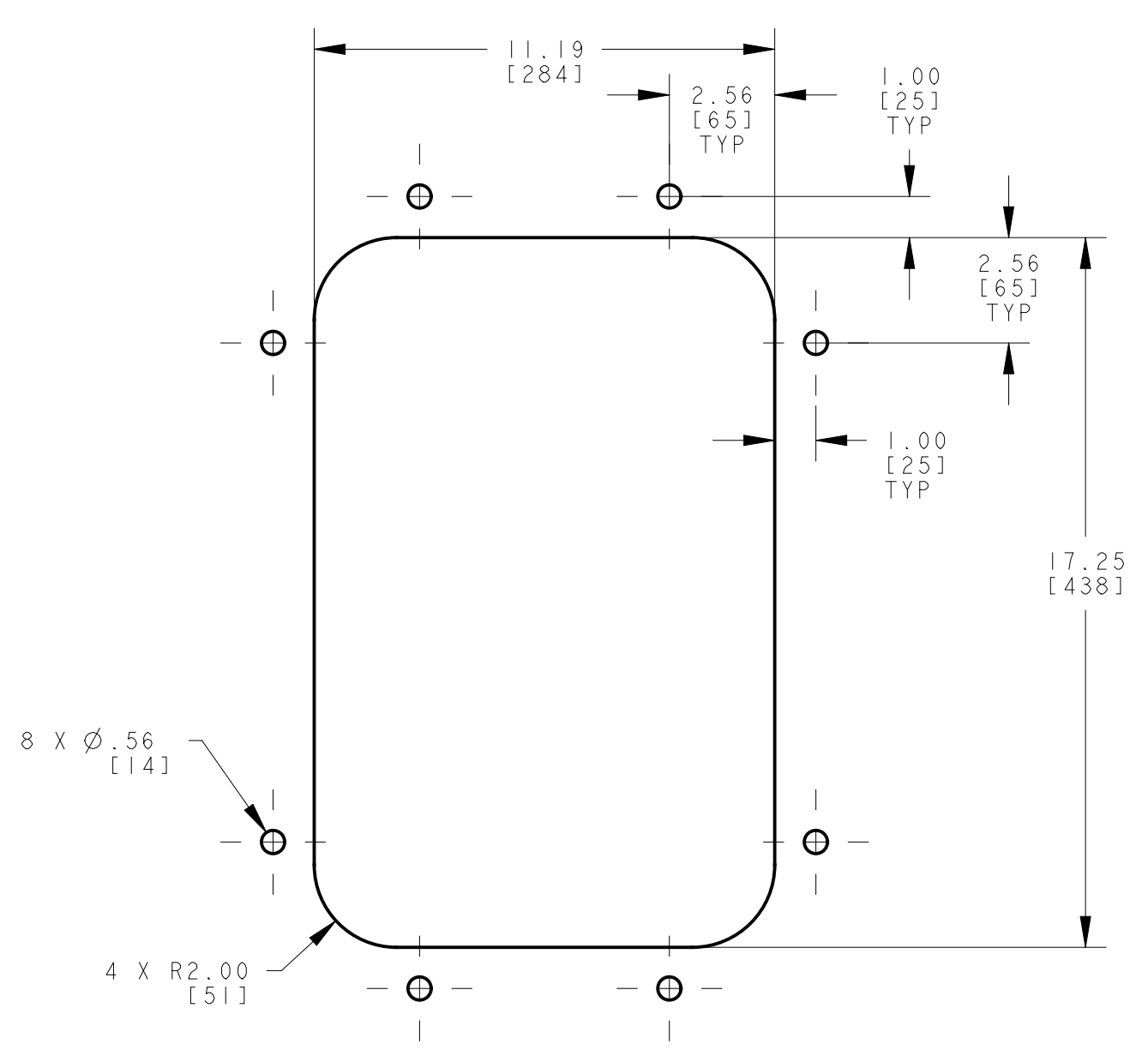

ACCESS DOOR CUTOUT DETAIL
SCALE 1/4

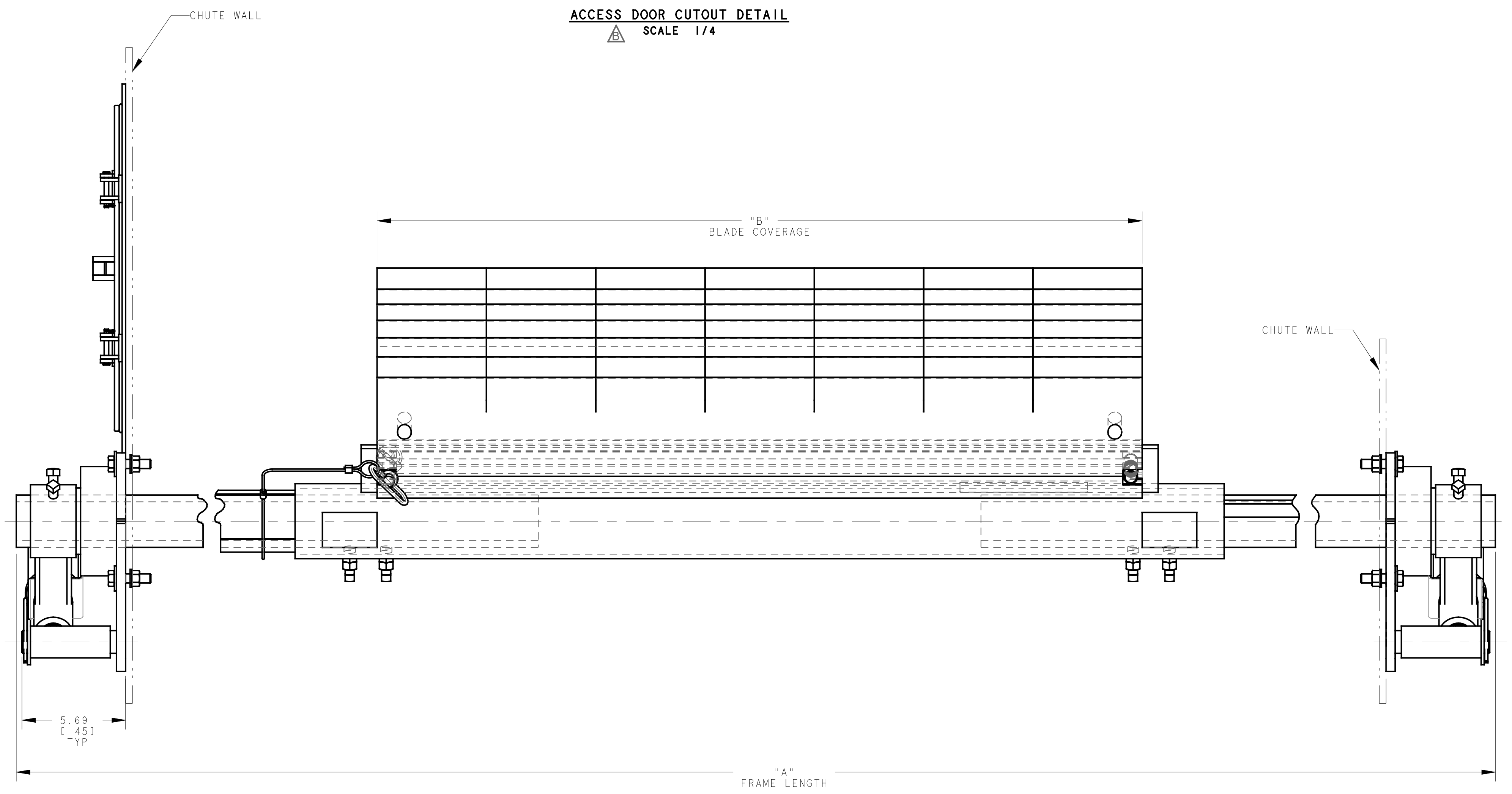

- NOTES:
- 1) ALL DIMENSIONS ARE GIVEN IN INCHES [MM].
 - 2) ALL DIMENSIONS ARE FOR REFERENCE ONLY.
 - 3) FOR EASY ACCESSIBILITY AND MAINTENANCE, MARTIN ENGINEERING RECOMMENDS BOLTING CLEANER TO EXISTING STRUCTURE WHEN APPLICABLE.
 - 4) CLEANER IS SHOWN IN RECOMMENDED WORKING POSITION.
 - 5) WHERE EXTREME OR UNUSUAL CONDITIONS EXIST, OR SPECIAL MAINFRAME LENGTHS ARE REQUIRED CONTACT MARTIN ENGINEERING.
 - 6) REFER TO OPERATOR'S MANUALS M3504, & M3127 FOR COMPLETE INSTALLATION INSTRUCTIONS.
 - 7) FOR BELT WIDTHS 42.00 [1067-1200] AND SMALLER, MARTIN ENGINEERING RECOMMENDS USING A SINGLE SPRING LEVER SHOCK MOUNT TENSIONER.
 - 8) CLEANER CAN BE LOCATED ANYWHERE ALONG THE ARC, AS LONG AS THE MAINFRAME IS OUT OF MATERIAL TRAJECTORY AND THE BLADE TIPS ARE BELOW THE HORIZONTAL CENTERLINE OF THE HEAD PULLEY.
 - 9) THE XHD QC#1 PRE-CLEANER BLADES ARE DESIGNED TO REMOVE HEAVY CARRYBACK ONLY. DO NOT OVERTENSION.
 - 10) ONE FULL TURN OF THE TENSIONING NUT ON THE SPRING TENSIONER IS EQUAL TO .20 [5].
 - 11) BLADE COVERAGE IS LESS THAN BELT WIDTH, DUE TO POSSIBLE MISTRACKING OR DAMAGED EDGES OF THE BELT.
 - 12) THE FIRST TWO XX'S OF THE CLEANER PART NUMBER INDICATE BELT WIDTH. THE THIRD X INDICATES SOLID (1) OR SLIT (0). THE FOURTH X INDICATES SOLID (1) OR SEGMENTED (0). THE NEXT TWO XX'S INDICATE BLADE WIDTH. THE LAST TWO XX'S INDICATE BLADE COLOR/MATERIAL.
EXAMPLE: 35899-481142BR (48.00 BELT WIDTH, 42.00 SOLID, BROWN BLADE).

ITEM	QTY.	DESCRIPTION	PART NUMBER
1	1	MARTIN® QC#1 XHD ASSEMBLY	SEE CHART
2	1	MARTIN® XHD DUAL SPRING TENSIONER	38003-2
3	1	MARTIN® LOW PROFILE ACCESS DOOR	CYA-1218

NO.	DESCRIPTION	ECN	DATE	BY
E	RMVD P/N 35899-XXXXXXBIX, COLOR OPTION BLACK FROM CHART	1564T	04/17/20	JAH
D	ADDED P/N 35899-XXXXXXYLX TO *ONLY OFFERED IN SEGMENTED (10)* OPTION	1517Z	08/16/18	JAH
C	ADDED 35899-XXXXXXBIX & -XXXXXXCYX TO THE CHART	----	04/30/12	MJB
B	UPDATED BLADE PROFILE AND DIMS / UPDATED NOTES AND CHARTS / CHG 34855-1218 TO CYA-1218 AND UPDATED CHUTE CUTOUT DETAIL	12574	03/04/09	JAP
A	ADDED MOUNTING LOCATION CHART/RMVD NOTE	11013	04/28/04	MJB

©Copyright 2020 Martin Engineering. All rights reserved. Covered by U.S. and foreign patents pending and issued. ® and TM indicate trademarks of Martin Engineering.

MARTIN ENGINEERING
NEPONSET, IL USA

TITLE
MARTIN® QC#1 XHD PRE-CLEANER WITH XHD DUAL SPRING TENS & 12X18 ACCESS DOOR

SALES DRAWING

DRAWN RND
DATE 01/31/06
CHECKED
ENG. JAP
DATE 02/07/06
APPROVED JMM
DATE 02/07/06
SCALE 1/4

REVISION
PR10311
S50033-D