

PART NUMBER	BELT WIDTH	DIMENSION "A" BLADE COVERAGE	DIMENSION "B" FRAME LENGTH
C1QCH3S54S8XXPX	1371.6 [54.00]	1168.4 [46.00]	2133.6 [84.00]
C1QCH3S54S6XXPX	1371.6 [54.00]	1219.2 [48.00]	2133.6 [84.00]
C1QCH3S54S4XXPX	1371.6 [54.00]	1270.0 [50.00]	2133.6 [84.00]
C1QCH3S60S8XXPX	1524.0 [60.00]	1320.8 [52.00]	2286.0 [90.00]
C1QCH3S60S6XXPX	1524.0 [60.00]	1371.6 [54.00]	2286.0 [90.00]
C1QCH3S60S4XXPX	1524.0 [60.00]	1422.4 [56.00]	2286.0 [90.00]
C1QCH3S66S8XXPX	1676.4 [66.00]	1473.2 [58.00]	2438.4 [96.00]
C1QCH3S66S6XXPX	1676.4 [66.00]	1524.0 [60.00]	2438.4 [96.00]
C1QCH3S66S4XXPX	1676.4 [66.00]	1574.8 [62.00]	2438.4 [96.00]
C1QCH3S72S8XXPX	1828.8 [72.00]	1625.6 [64.00]	2590.8 [102.00]
C1QCH3S72S6XXPX	1828.8 [72.00]	1676.4 [66.00]	2590.8 [102.00]
C1QCH3S72S4XXPX	1828.8 [72.00]	1727.2 [68.00]	2590.8 [102.00]
C1QCH3S78S8XXPX	1981.2 [78.00]	1778.0 [70.00]	2743.2 [108.00]
C1QCH3S78S6XXPX	1981.2 [78.00]	1828.8 [72.00]	2743.2 [108.00]
C1QCH3S78S4XXPX	1981.2 [78.00]	1879.6 [74.00]	2743.2 [108.00]
C1QCH3S84S8XXPX	2133.6 [84.00]	1930.4 [76.00]	2895.6 [114.00]
C1QCH3S84S6XXPX	2133.6 [84.00]	1981.2 [78.00]	2895.6 [114.00]
C1QCH3S84S4XXPX	2133.6 [84.00]	2032.0 [80.00]	2895.6 [114.00]
C1QCH3S90S8XXPX	2286.0 [90.00]	2082.8 [82.00]	3048.0 [120.00]
C1QCH3S90S6XXPX	2286.0 [90.00]	2133.6 [84.00]	3048.0 [120.00]
C1QCH3S90S4XXPX	2286.0 [90.00]	2184.4 [86.00]	3048.0 [120.00]
C1QCH3S96S8XXPX	2438.4 [96.00]	2235.2 [88.00]	3200.4 [126.00]
C1QCH3S96S6XXPX	2438.4 [96.00]	2286.0 [90.00]	3200.4 [126.00]
C1QCH3S96S4XXPX	2438.4 [96.00]	2336.8 [92.00]	3200.4 [126.00]
C1QCH3A2S8XXPX	2590.8 [102.00]	2387.6 [94.00]	3352.8 [132.00]
C1QCH3A2S6XXPX	2590.8 [102.00]	2438.4 [96.00]	3352.8 [132.00]
C1QCH3A2S4XXPX	2590.8 [102.00]	2489.2 [98.00]	3352.8 [132.00]
C1QCH3A8S8XXPX	2743.2 [108.00]	2540.0 [100.00]	3505.2 [138.00]
C1QCH3A8S6XXPX	2743.2 [108.00]	2590.8 [102.00]	3505.2 [138.00]
C1QCH3A8S4XXPX	2743.2 [108.00]	2641.6 [104.00]	3505.2 [138.00]

- NOTES:
- ALL DIMENSIONS ARE GIVEN IN MILLIMETERS [INCHES] AND ARE FOR REFERENCE ONLY.
 - IN THE C1QCH3 PART NUMBER THE FIRST SXX INDICATES THE BELT WIDTH IN STANDARD INCH UNITS FOR BELT WIDTHS 54 THRU 108.
 S54 = 54
 S96 = 96
 SA2 = 102
 SA8 = 108
 THE NEXT SX INDICATES THE LESS BELT WIDTH BLADE COVERAGE IN STANDARD INCH UNITS.
 00 = NO BLADE
 S4 = 4 LESS BELT WIDTH
 S6 = 6 LESS BELT WIDTH
 S8 = 8 LESS BELT WIDTH
 THE FOURTH X IN THE PART NUMBER INDICATES THE BLADE COLOR:
 0 = NO BLADE
 B = BROWN
 T = TAN
 G = GREEN
 N = NAVY BLUE
 O = ORANGE
 C = YELLOW WITH CERAMIC BEADS (72.00 MAX. BLADE WIDTH)
 THE FIFTH X INDICATES IF THE BLADE IS SOLID OR SEGMENTED:
 0 = SEGMENTED BLADE / NO BLADE
 1 = SOLID BLADE / CERAMIC BLADE ONLY AVAILABLE AS SOILD
 THE P IN THE PART NUMBER INDICATES A PAINTED STEEL MAINFRAME
 THE LAST X INDICATES THE TENSIONER OPTIONS:
 BLANK = NO TENSIONER
 T = TWIST TENSIONER (38850-2)
 S = SPRING TENSIONER (38180-2)
 ADD AN L TO THE END OF THE PART NUMBER TO GET A CLEANER LESS THE TORQUE TUBES.
 3) THE FRAME IS ADJUSTABLE TO DESIRED LENGTH.
 4) FOR BELT WIDTHS 48 AND UNDER A SINGLE TWIST TENSIONER ASSEMBLY IS REQUIRED (P/N 38850). SEE S50129-TS.
 5) WHERE EXTREME OR UNUSUAL CONDITIONS EXIST, OR SPECIAL MAINFRAME LENGTHS ARE REQUIRED CONTACT MARTIN ENGINEERING.
 6) INSIDE CHUTE WALL WIDTH MUST BE A MINIMUM OF BELT WIDTH PLUS 127.0 [5.00] IN ORDER FOR CLEANER TO BE INSTALLED WITH TENSIONERS BOLTED DIRECTLY TO CHUTE WALL.
 7) REFER TO OPERATOR'S MANUALS M3837 AND M4124 FOR INSTALLATION INSTRUCTIONS.
 8) CLEANER CAN BE LOCATED ANYWHERE ALONG THE ARC, AS LONG AS THE MAINFRAME IS OUT OF MATERIAL TRAJECTORY AND THE BLADE TIPS ARE BELOW THE HORIZONTAL CENTERLINE OF THE HEAD PULLEY.
 9) THE QC1+ HD PRE-CLEANER BLADE IS DESIGNED TO REMOVE THE INITIAL CARRYBACK ONLY. DO NOT OVER TENSION.
 10) THE QC1+ HD PRE-CLEANER BLADE IS DESIGNED FOR HEAD PULLEYS WITH A DIAMETER OF 406.4 [16.00] TO 558.8 [22.00].
 11) BLADE COVERAGE IS LESS THAN BELT WIDTH, DUE TO POSSIBLE MISTRACKING OR DAMAGED EDGES OF THE BELT.

ASSEMBLY PART NO.	COLOR
C1QCH3SXXXSXBXPX	BROWN
C1QCH3SXXSXTXPX	TAN
C1QCH3SXXSXGXPX	GREEN
C1QCH3SXXSXNXPX	NAVY BLUE
C1QCH3SXXSXOXXPX	ORANGE
C1QCH3SXXSXCPX	YELLOW WITH CERAMIC BEADS

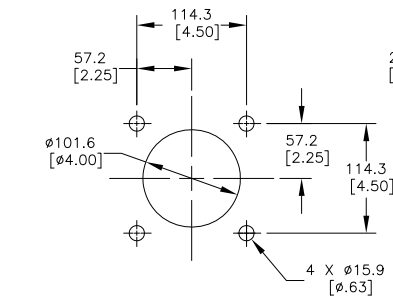

TENSIONER CHUTE WALL CUTOUT DETAIL
TYPICAL BOTH SIDES

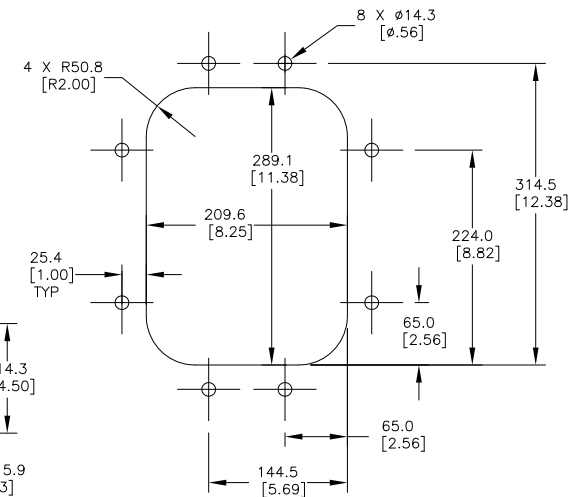

DOOR CUTOUT DETAIL
FOR STEEL ACCESS DOOR

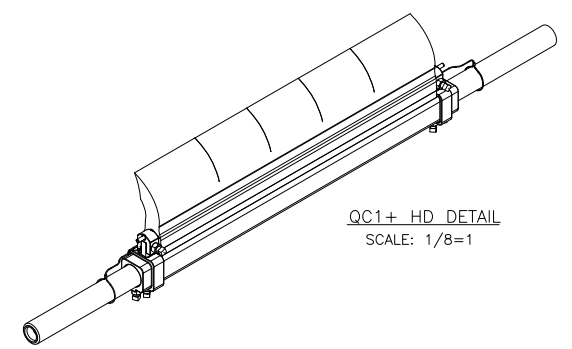

QC1+ HD DETAIL
SCALE: 1/8=1

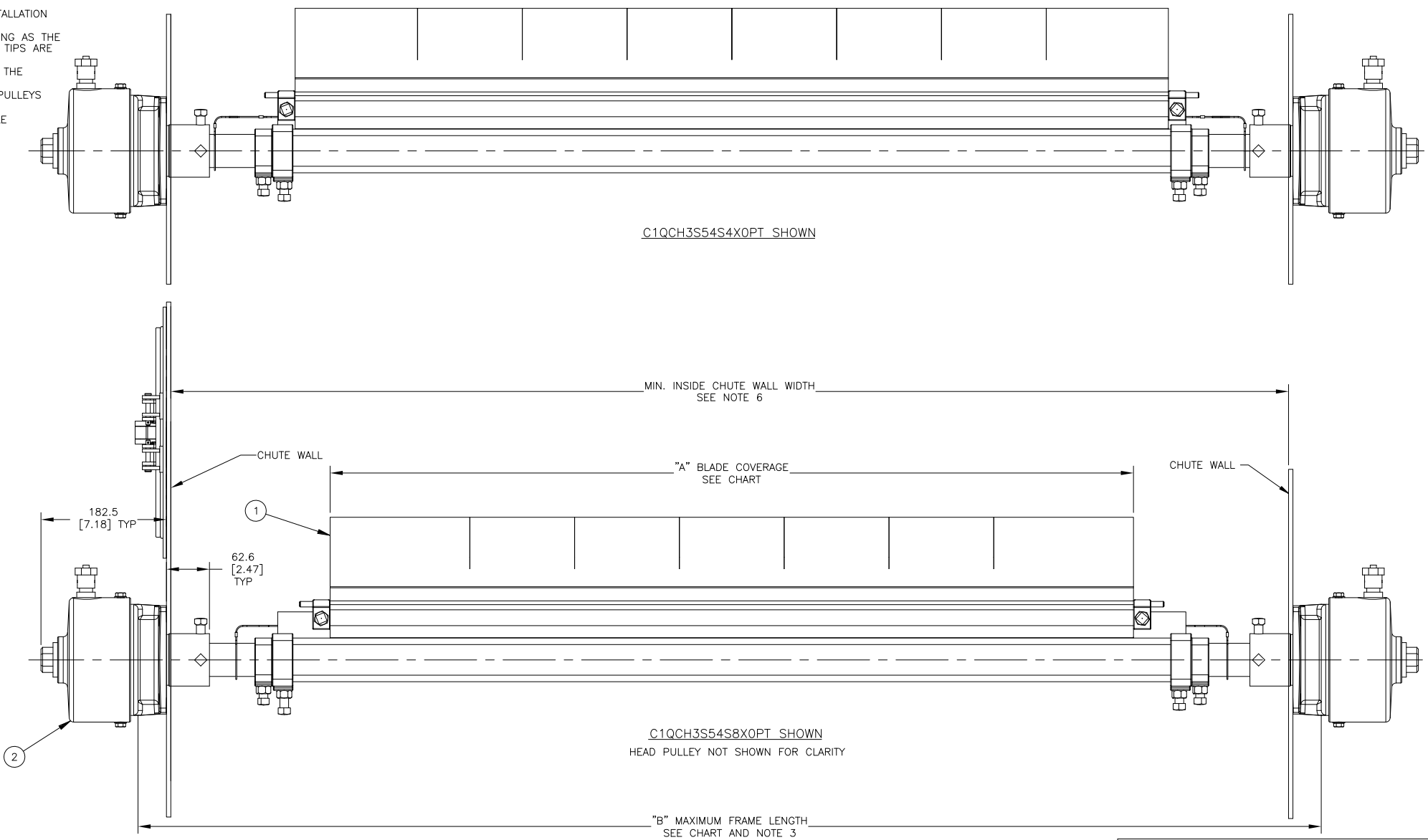
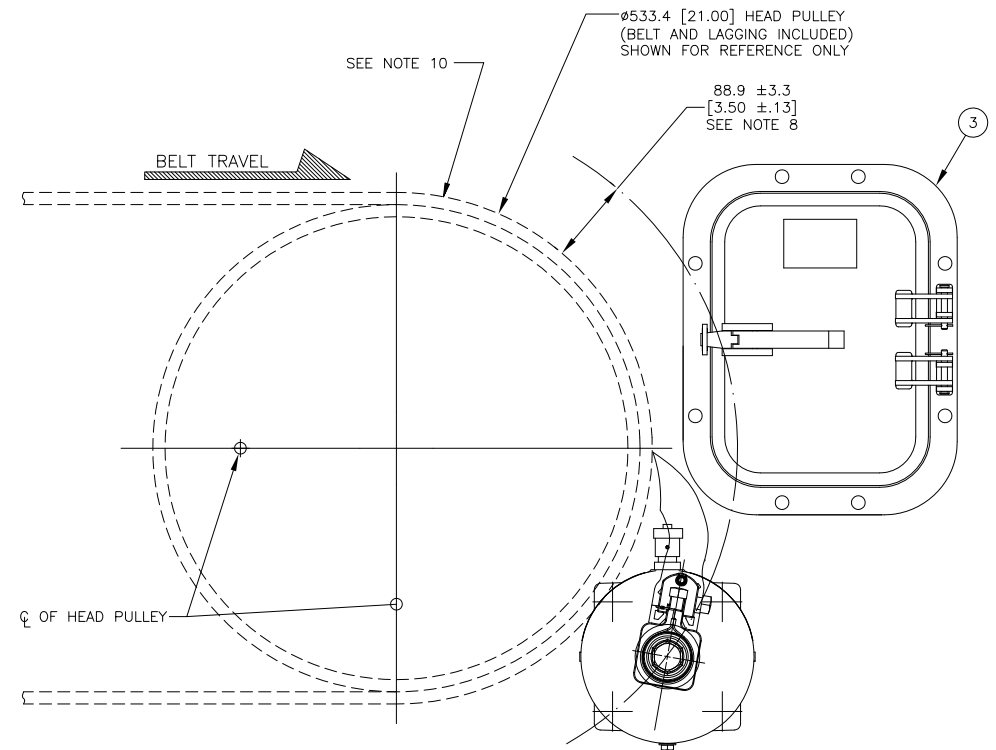

© Copyright 2019 Martin Engineering. All rights reserved. Covered by U.S. and foreign patents pending and issued. ® and TM indicate trademarks of Martin Engineering.

MARTIN ENGINEERING
NEPONSET, IL USA

TITLE	MARTIN QC1+ HD 3-PC ASM WITH DUAL TWIST TENS ASM & STEEL DOOR	228.6 [9] X 304.8 [12]
DATE	05/02/19	CHECKED
ENG.	JAH	DATE 05/29/19
APPROVED	JAH	DATE 05/29/19
SALES DRAWING	S50129-TD	SCALE 1/4

NO.	DESCRIPTION	ECN	DATE	BY
A	UPDATED P/N NOTE	15751	10/06/20	JAH

AutoCAD REVISION