

PART NUMBER	BELT WIDTH	DIMENSION "A" BLADE COVERAGE	DIMENSION "B" FRAME LENGTH
C1QCH3S54S8XXFX	1371.6 [54.00]	1168.4 [46.00]	2133.6 [84.00]
C1QCH3S54S6XXFX	1371.6 [54.00]	1219.2 [48.00]	2133.6 [84.00]
C1QCH3S54S4XXFX	1371.6 [54.00]	1270.0 [50.00]	2133.6 [84.00]
C1QCH3S60S8XXFX	1524.0 [60.00]	1320.8 [52.00]	2286.0 [90.00]
C1QCH3S60S6XXFX	1524.0 [60.00]	1371.6 [54.00]	2286.0 [90.00]
C1QCH3S60S4XXFX	1524.0 [60.00]	1422.4 [56.00]	2286.0 [90.00]
C1QCH3S66S8XXFX	1676.4 [66.00]	1473.2 [58.00]	2438.4 [96.00]
C1QCH3S66S6XXFX	1676.4 [66.00]	1524.0 [60.00]	2438.4 [96.00]
C1QCH3S66S4XXFX	1676.4 [66.00]	1574.8 [62.00]	2438.4 [96.00]
C1QCH3S72S8XXFX	1828.8 [72.00]	1625.6 [64.00]	2590.8 [102.00]
C1QCH3S72S6XXFX	1828.8 [72.00]	1676.4 [66.00]	2590.8 [102.00]
C1QCH3S72S4XXFX	1828.8 [72.00]	1727.2 [68.00]	2590.8 [102.00]
C1QCH3S78S8XXFX	1981.2 [78.00]	1778.0 [70.00]	2743.2 [108.00]
C1QCH3S78S6XXFX	1981.2 [78.00]	1828.8 [72.00]	2743.2 [108.00]
C1QCH3S78S4XXFX	1981.2 [78.00]	1879.6 [74.00]	2743.2 [108.00]
C1QCH3S84S8XXFX	2133.6 [84.00]	1930.4 [76.00]	2895.6 [114.00]
C1QCH3S84S6XXFX	2133.6 [84.00]	1981.2 [78.00]	2895.6 [114.00]
C1QCH3S84S4XXFX	2133.6 [84.00]	2032.0 [80.00]	2895.6 [114.00]
C1QCH3S90S8XXFX	2286.0 [90.00]	2082.8 [82.00]	3048.0 [120.00]
C1QCH3S90S6XXFX	2286.0 [90.00]	2133.6 [84.00]	3048.0 [120.00]
C1QCH3S90S4XXFX	2286.0 [90.00]	2184.4 [86.00]	3048.0 [120.00]
C1QCH3S96S8XXFX	2438.4 [96.00]	2235.2 [88.00]	3200.4 [126.00]
C1QCH3S96S6XXFX	2438.4 [96.00]	2286.0 [90.00]	3200.4 [126.00]
C1QCH3S96S4XXFX	2438.4 [96.00]	2336.8 [92.00]	3200.4 [126.00]
C1QCH3S2S8XXFX	2590.8 [102.00]	2387.6 [94.00]	3352.8 [132.00]
C1QCH3S2S6XXFX	2590.8 [102.00]	2438.4 [96.00]	3352.8 [132.00]
C1QCH3S2S4XXFX	2590.8 [102.00]	2489.2 [98.00]	3352.8 [132.00]
C1QCH3S8S8XXFX	2743.2 [108.00]	2540.0 [100.00]	3505.2 [138.00]
C1QCH3S8S6XXFX	2743.2 [108.00]	2590.8 [102.00]	3505.2 [138.00]
C1QCH3S8S4XXFX	2743.2 [108.00]	2641.6 [104.00]	3505.2 [138.00]

- NOTES:
- ALL DIMENSIONS ARE GIVEN IN MILLIMETERS [INCHES] AND ARE FOR REFERENCE ONLY.
 - IN THE C1QCH3 PART NUMBER THE FIRST SXX INDICATES THE BELT WIDTH IN STANDARD INCH UNITS FOR BELT WIDTHS 54 THRU 108.
S54 = 54
S96 = 96
S84 = 84
S72 = 72
S66 = 66
S60 = 60
S54 = 54
 - THE NEXT SIX INDICATES THE LESS BELT WIDTH BLADE COVERAGE IN STANDARD INCH UNITS.
00 = NO BLADE
S4 = 4 LESS BELT WIDTH
S6 = 6 LESS BELT WIDTH
S8 = 8 LESS BELT WIDTH
 - THE FOURTH X IN THE PART NUMBER INDICATES THE BLADE COLOR:
0 = NO BLADE
B = BROWN
T = TAN
G = GREEN
N = NAVY BLUE
O = ORANGE
 - THE FIFTH X INDICATES IF THE BLADE IS SOLID OR SEGMENTED:
0 = SEGMENTED BLADE / NO BLADE
1 = SOLID BLADE
 - THE F IN THE PART NUMBER INDICATES A STAINLESS STEEL MAINFRAME THE LAST X INDICATES THE TENSIONER OPTIONS:
BLANK = NO TENSIONER
F = STAINLESS STEEL TWIST TENSIONER (31443-DSS)
P = STAINLESS STEEL SPRING TENSIONER (38180-2SS)
 - ADD AN L TO THE END OF THE PART NUMBER TO GET A CLEANER LESS THE TORQUE TUBES.
 - THE FRAME IS ADJUSTABLE TO DESIRED LENGTH.
 - FOR BELT WIDTHS 48.00 AND UNDER A SINGLE SPRING TENSIONER ASSEMBLY IS REQUIRED (P/N 38180-SS). SEE S50129-SSS.
 - WHERE EXTREME OR UNUSUAL CONDITIONS EXIST, OR SPECIAL MAINFRAME LENGTHS ARE REQUIRED CONTACT MARTIN ENGINEERING.
 - SPRING TENSIONER MAY BE BOLTED OR WELDED IN PLACE. MARTIN ENGINEERING RECOMMENDS BOLTING WHEN APPLICABLE FOR EASIER MAINTENANCE AND ACCESSIBILITY.
 - REFER TO OPERATOR'S MANUALS M3263 AND M4124 FOR INSTALLATION INSTRUCTIONS.
 - CLEANER CAN BE LOCATED ANYWHERE ALONG THE ARC, AS LONG AS THE MAINFRAME IS OUT OF MATERIAL TRAJECTORY AND THE BLADE TIPS ARE BELOW THE HORIZONTAL CENTERLINE OF THE HEAD PULLEY.
 - THE QC1+ HD PRE-CLEANER BLADE IS DESIGNED TO REMOVE THE INITIAL CARRYBACK ONLY. DO NOT OVER TENSION.
 - THE QC1+ HD PRE-CLEANER BLADE IS DESIGNED FOR HEAD PULLEYS WITH A DIAMETER OF 406.4 [16.00] TO 558.8 [22.00].
 - BLADE COVERAGE IS LESS THAN BELT WIDTH, DUE TO POSSIBLE MISTRACKING OR DAMAGED EDGES OF THE BELT.
 - INSIDE CHUTE WALL WIDTH MUST BE A MINIMUM OF BELT WIDTH PLUS 127.0 [5.00] IN ORDER FOR CLEANER TO BE INSTALLED WITH TENSIONERS BOLTED DIRECTLY TO CHUTE WALL.

ASSEMBLY PART NO.	COLOR
C1QCH3SXXSXBFX	BROWN
C1QCH3SXXSXTFX	TAN
C1QCH3SXXSXGFX	GREEN
C1QCH3SXXSXNFX	NAVY BLUE
C1QCH3SXXSXOXFX	ORANGE

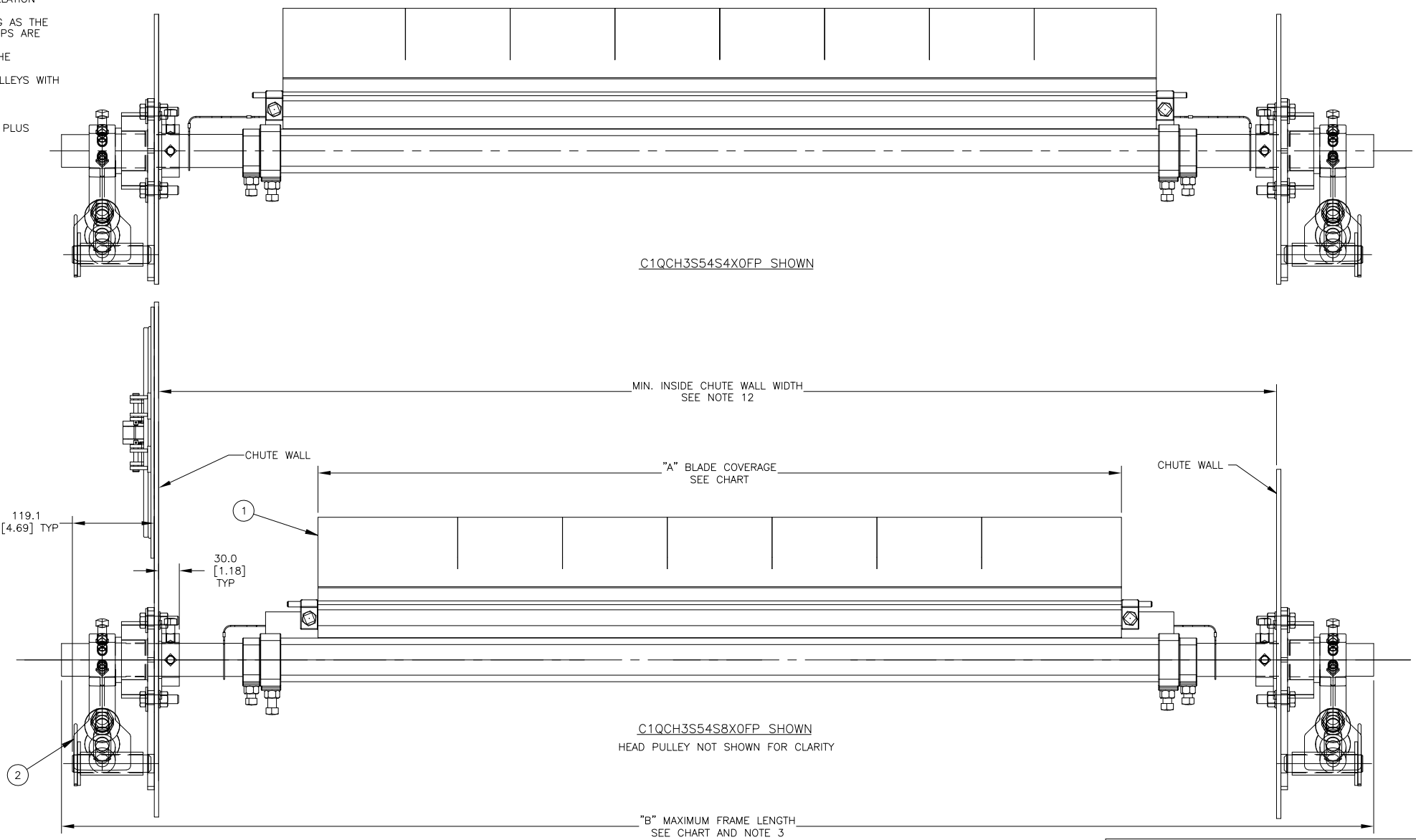
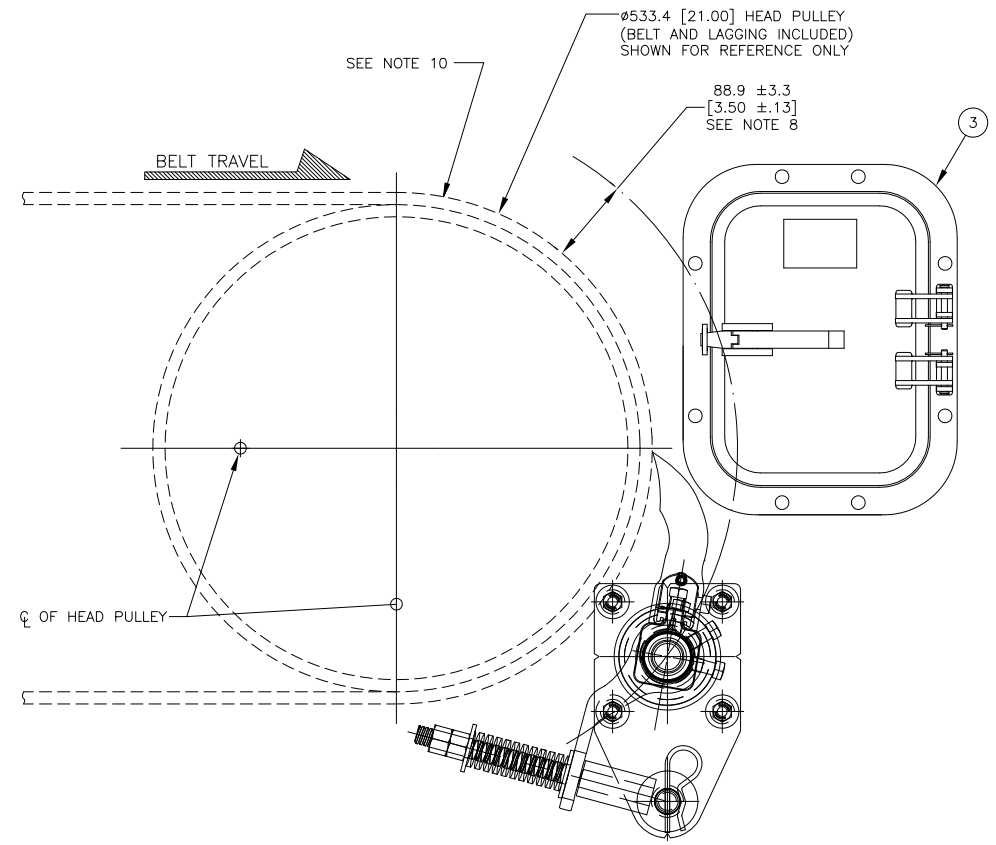
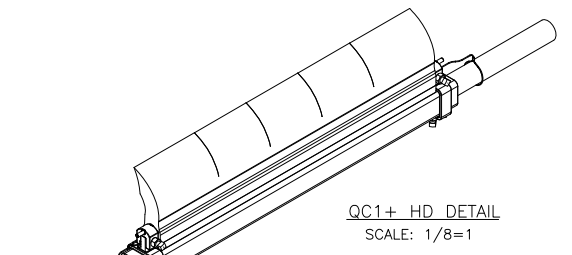
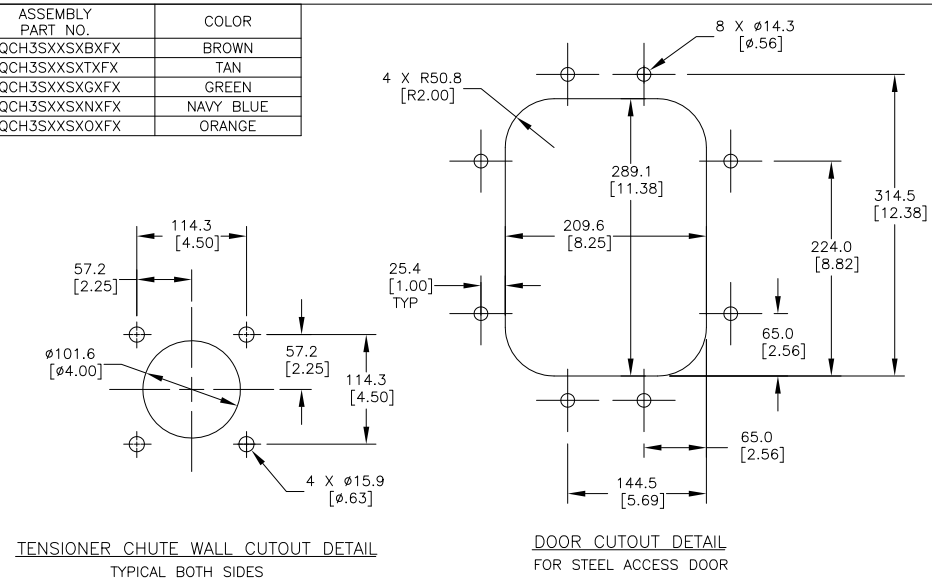

© Copyright 2019 Martin Engineering. All rights reserved. Covered by U.S. and foreign patents pending and issued. ® and TM indicate trademarks of Martin Engineering.

MARTIN ENGINEERING
NEPONSET, IL USA

TITLE: MARTIN QC1+ HD SS 3-PC ASM DUAL SS SPR TENS ASM & SS STEEL DOOR 228.6 [9] X 304.8 [12]

DRAWN RND DATE 05/14/19
CHECKED
ENG. 743
DATE 05/29/19
APPROVED 743
DATE 05/29/19
SCALE 1/4

NO.	DESCRIPTION	ECN	DATE	BY
A	UPDATED P/N NOTE	15751	10/06/20	JAH

SALES DRAWING S50129-SDS

NO.	DESCRIPTION	ECN	DATE	BY
A	UPDATED P/N NOTE	15751	10/06/20	JAH