

***martin***<sup>®</sup>

***Martin***<sup>®</sup>  
***Electric Vibrators***

[Go to Martin<sup>®</sup> Electric Vibrators web page](#)



***Operator's Manual***  
***M3910***

# Important

MARTIN ENGINEERING HEREBY DISCLAIMS ANY LIABILITY FOR: DAMAGE DUE TO CONTAMINATION OF THE MATERIAL; USER'S FAILURE TO INSPECT, MAINTAIN AND TAKE REASONABLE CARE OF THE EQUIPMENT; INJURIES OR DAMAGE RESULTING FROM USE OR APPLICATION OF THIS PRODUCT CONTRARY TO INSTRUCTIONS AND SPECIFICATIONS CONTAINED HEREIN. MARTIN ENGINEERING'S LIABILITY SHALL BE LIMITED TO REPAIR OR REPLACEMENT OF EQUIPMENT SHOWN TO BE DEFECTIVE.

Observe all safety rules given herein along with owner and Government standards and regulations. Know and understand lockout/tagout procedures as defined by American National Standards Institute (ANSI) z244.1-1982, *American National Standard for Personnel Protection - Lockout/Tagout of Energy Sources - Minimum Safety Requirements* and Occupational Safety and Health Administration (OSHA) Federal Register, Part IV, 29 CFR Part 1910, *Control of Hazardous Energy Source (Lockout/Tagout); Final Rule*.

The following symbols may be used in this manual:



**Danger:** Immediate hazards that will result in severe personal injury or death.



**Warning:** Hazards or unsafe practices that could result in personal injury.



**Caution:** Hazards or unsafe practices that could result in product or property damages.



**Important:** Instructions that must be followed to ensure proper installation/operation of equipment.



**Note:** General statements to assist the reader.

# Table of Contents

---

<b>Section</b>	<b>Page</b>
List of Figures .....	ii
List of Tables .....	ii
Introduction .....	1
General .....	1
References .....	1
Safety .....	1
Materials required .....	1
Storage .....	2
Before Installing Vibrator .....	3
Installing Vibrator .....	4
Mounting vibrator onto structure .....	4
Nut and cap screw torque .....	8
Connecting power to vibrator .....	8
Installing overload, short-circuit, and ground-fault protection .....	13
After Installing Vibrator .....	14
Checking shaft rotation .....	14
Adjusting eccentric weights for 00–10 frame .....	14
Adjusting eccentric weights for 20–105 frame .....	17
Initial start up/checking line current .....	19
Variable frequency inverter .....	20
Maintenance .....	21
Lubricating vibrator .....	21
Repairing motor and replacing bearings .....	23
Inspecting vibrator .....	23
Part Numbers .....	24
Appendix. Martin <sup>®</sup> Electric Vibrator Dimensions .....	A-1

## **List of Figures**

---

<b>Figure</b>	<b>Title</b>	<b>Page</b>
1	Locating Vibrator on Hoppers . . . . .	4
2	W-beam Mount . . . . .	5
3	Mounting Bolt Tightening Sequence . . . . .	6
4	Installing Restraining Cable . . . . .	7
5	Cord Grip Installation . . . . .	9
6	Single Phase Wiring Diagrams . . . . .	10
7	Three Phase Wiring Diagrams. . . . .	11
8	Installing Wire Connector . . . . .	12
9	Adjusting Eccentric Weights . . . . .	15
10	Adjusting Eccentric Weights . . . . .	18
11	Example of Adjustable Weights Set at 50% . . . . .	18
12	Setting Sets of Eccentric Weights to Mirror Images . . . . .	19

## **List of Tables**

---

<b>Table</b>	<b>Title</b>	<b>Page</b>
I	Mounting Bolts and Torque Requirements . . . . .	6
II	Vibrator Nut and Cap Screw Torque Requirements . . . . .	8
III	Cord Grip Specifications . . . . .	9
IV	Eccentric Weight Settings . . . . .	15
V	Lubrication Schedule For Each Bearing . . . . .	22
VI	Martin <sup>®</sup> Electric Vibrator Model Numbers and Part Numbers . . . . .	24

# Introduction

---

## **General**

Martin® Electric Vibrators (M Series) are designed and manufactured to ensure the best performance and reliability in severe-duty applications. The vibrator motor has a recommended operational ambient temperature and mounting surface temperature range of -22 to 104°F (-30 to 40°C). If operating the motor in environments beyond these temperatures, call Martin Engineering, as the vibrator may require rating reduction, more frequent lubrication, or lubrication substitution.

The vibrators in this manual may be referred to by their model numbers or part numbers. Table VI in the “Part Numbers” section provides model numbers and part numbers together with frame size. The following letter designations are used throughout this manual:

- MM (Martin® Vibrator bolt pattern).
- MC (Cougar® Vibrator bolt pattern)
- MI (Invicta Vibrator bolt pattern)
- MV (Vimarc® Vibrator bolt pattern)
- MU (Uras® Vibrator bolt pattern)
- MB (Bosch® Vibrator bolt pattern)

## **References**

The following documents are referenced in this manual:

- *The National Electrical Code (NEC)*, National Fire Protection Association, 1 Batterymarch Park, P.O. Box 9101, Quincy MA 02269-9101.
- American National Standards Institute (ANSI) z244.1-1982, *American National Standard for Personnel Protection - Lockout/Tagout of Energy Sources - Minimum Safety Requirements*, American National Standards Institute, Inc., 1430 Broadway, New York, NY 10018.
- Code of Federal Regulation (CFR) 29, Part 1910, *Control of Hazardous Energy Source (Lockout/Tagout); Final Rule*, Department of Labor, Occupational Safety and Health Administration (OSHA), 32nd Floor, Room 3244, 230 South Dearborn Street, Chicago, IL 60604.
- CFR 29, Part 1910.15, *Occupational Noise Exposure*, Department of Labor, OSHA, 32nd Floor, Room 3244, 230 South Dearborn Street, Chicago, IL 60604.

## **Safety**

All safety rules defined in the above documents and all owner/employer safety rules must be strictly followed when working on the vibrator.

## **Materials required**

In addition to metric hand tools, the following materials are required to install this equipment:

- Rigid beam or mounting plate.
- Martin® BBAC Cable Kit, P/N 32271, or equivalent.

(Mount Kit for Electric Vibrators, P/N 32401-XX includes W-beam Mount, mounting hardware, and Martin® BBAC Safety Cable Kit.)

## *Storage*

Store vibrator in an ambient temperature not less than 41°F (5°C) with a relative humidity not more than 60%. If the vibrator has been stored for 2 or more years, remove bearings, wash them, and repack them with new grease (see “Maintenance”).

# Before Installing Vibrator

---

## IMPORTANT

The delivery service is responsible for damage occurring in transit. Martin Engineering CANNOT enter claims for damages. Contact your transportation agent for more information.

1. Inspect shipping container/pallet for damage. Report damage to delivery service immediately and fill out delivery service's claim form. Keep any damaged goods subject to examination.
2. Remove vibrator from shipping container/pallet.
3. If anything is missing contact Martin Engineering or a representative.



## WARNING

Turn off and lockout / tagout / blockout / testout all energy sources to conveyor/loading systems to mounting structure.

4. Before installing vibrator, turn off and lockout / tagout / blockout / testout all energy sources to conveyor/loading systems to mounting structure according to ANSI standards (see "References").

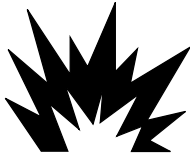

## WARNING

If equipment will be installed in an enclosed area, gas level or dust content must be tested before using a cutting torch or welding. Using a cutting torch or welding in an area with gas or dust may cause an explosion.

5. If using a cutting torch or welding, test atmosphere for gas level or dust content.
6. Mounting surface must be strong and flat, 0.01 in. (0.25 mm) across vibrator feet. (This will minimize internal stress to vibrator casting when tightening mount bolts. Welding in the area of the mounting surface could affect its flatness.)
7. Make sure mounting surface is free of paint and debris and foot of vibrator is clean.

# Installing Vibrator

## IMPORTANT

Read entire section before beginning work.

## ▲ CAUTION

If installation instructions are not followed, structure and vibrator can be damaged. Abusing or handling vibrator carelessly will accelerate wear and shorten bearing life.

### *Mounting vibrator onto structure*

1. See Figure 1. Locate vibrator in lower 1/4 to 1/3 of structure slope length. If second vibrator is required, mount 180° from first vibrator and halfway up slope.

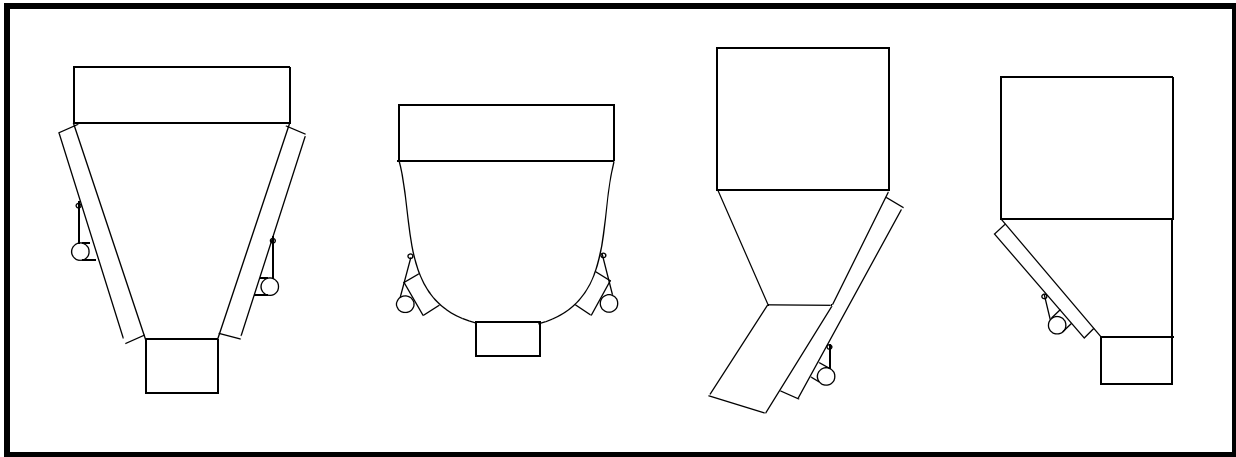

**Figure 1. Locating Vibrator on Hoppers**

## ▲ CAUTION

Never weld structure with vibrator mounted and wired. Welding may cause damage to motor windings and bearings.

## IMPORTANT

The object of rotary vibration on bins, hoppers, and chutes is to transmit vibration through the wall into the product contained inside. If structure is not made rigid, vibrator may draw high amperage and move material less efficiently.

**Make sure structure is free of paint before mounting vibrator.**

2. If using customer-supplied mounting plate to mount vibrator onto structure, do the following:
  - a. Make sure plate is at least the size of vibrator base.
  - b. Locate plate so that vibrator can be positioned as shown in Figure 1.
  - c. Weld mounting plate onto structure.
3. If using Martin® W-beam Mount (or equivalent) to mount vibrator onto structure (see Figure 2), do the following:



- a. Make sure mount plate is positioned on channel so that vibrator shaft is always 90° to the length of the channel.
- b. Locate beam so that vibrator can be positioned as shown in Figure 1.
- c. Extend beam at least 3/4 the length of sloped wall. Cut off end(s) of beam if necessary to fit on structure.
- d. Skip-weld beam in place: Weld 3 in. (76 mm), then skip 2 in. (51 mm). Repeat for entire perimeter of beam. Do not weld last 1 in. (25 mm) of either end of beam or any corner.
- e. Install vibrator onto W-beam mount.

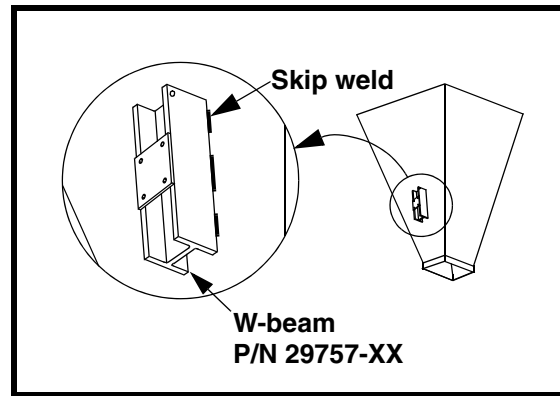

**Figure 2. W-beam Mount**

**⚠ CAUTION**

**Never weld structure with vibrator mounted and wired. Welding may cause damage to motor windings and bearings.**

**Use only new Grade 5 bolts and lock nuts to install vibrator. Old fasteners can break and cause damage to vibrator or structure.**

**Do not use split lock washers to install vibrator onto mount. Damage to vibrator could result.**

**Tighten mounting bolts in sequence shown in Figure 3. If not tightened in order, vibrator casting could be damaged.**

4. Before installing vibrator onto mount, apply thread sealing compound to all bolts.
5. Install vibrator onto mount with new lock nuts, compression washers, and bolts according to Table I. Tighten bolts in order given in Figure 3 to avoid damaging vibrator casting. (Contact fastener manufacturer for specific information regarding bolt torque.)

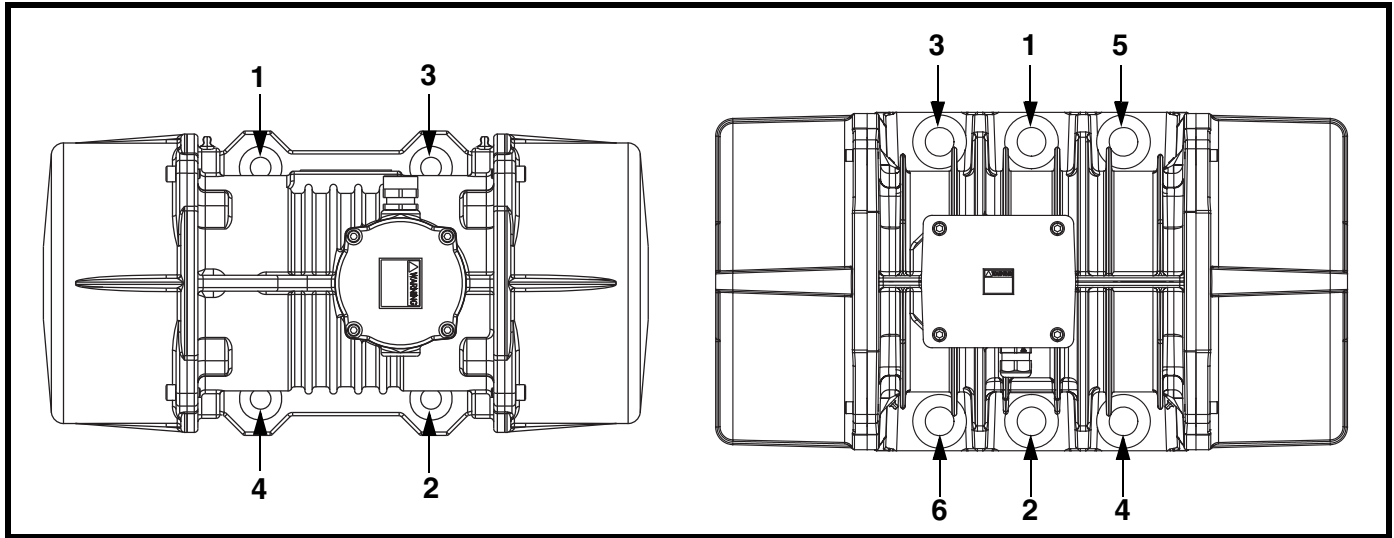

**Figure 3. Mounting Bolt Tightening Sequence**

6. After the vibrator has been operated for 10 to 20 minutes, check bolt torque. Tighten if necessary.

**Table I. Mounting Bolts and Torque Requirements\***

Vibrator Type	Frame Size*	English		Metric	
		Bolt Size (Gr 5)	Dry Torque (ft-lb)	Bolt Size	Dry Torque
MM	00	5/16 in. -18NC	15	M8	23 Nm
MM	10	3/8 in. -16NC	26	M10	42 Nm
MM	20	1/2 in. -13NC	64	M12	75 Nm
MM, MI, MV, MB	30, 33, 35, 40, 50	5/8 in. -11NC	128	M16	19 kgm
MC	30, 35	5/8 in. -11NC	128	M16	19 kgm
MC	40, 50	3/4 in. -10NC	227	M20	37 kgm
MM, MI, MV, MC	90, 95	1 in. -8NC	644	M25	89 kgm
MU	90, 95	1-1/2 in. -8NC	1950	M36	269 kgm
MM	97	1-1/2 in. -8NC	1950	M36	269 kgm
MI	97, 100	1 in. -8NC	644	M25	89 kgm
MM, MI	100, 105	1-3/4 in. -8NC	N/A	M42	290 kgm**

\*See "Part Numbers" section for specific model numbers.  
 \*\*Plated bolt with antiseize.

\*Torque specifications are for reference only. Contact fastener manufacturer for specific information regarding bolt torque.

## ⚠ WARNING

If vibrator is mounted more than 6 in. (152 mm) above ground, install cable securing vibrator to structure. Without cable, vibrator could fall and cause injury.

7. Secure vibrator to structure by installing Martin® BBAC Cable Kit, P/N 32271, or equivalent as follows (cable is included with Mount Kit for Electric Vibrators, P/N 32401-XX):

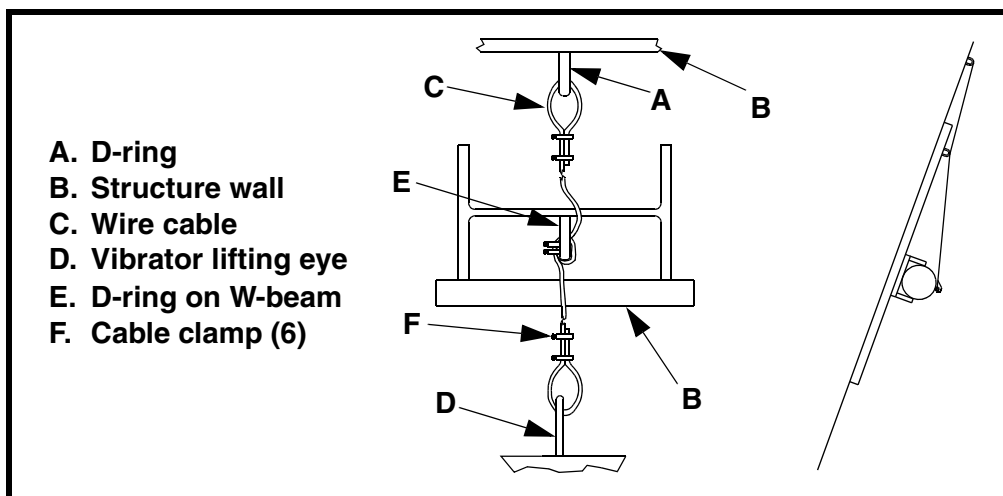

**Figure 4. Installing Restraining Cable**

- a. Weld D-ring (A, Figure 4) onto structure wall (B) above vibrator.
- b. Loop 1/4-in. (6 mm) wire cable (C) through vibrator lifting eye (D) and D-ring on structure wall.
- c. If using a Martin® W-beam Mount, also loop cable through D-ring on W-beam (E) as shown. Take up slack so cable is taut.
- d. Apply thread-sealing compound to nuts on cable clamps (F). Install six cable clamps (two on each end and two on loop around D-ring on W-beam) to secure cable to vibrator eye and D-rings. Torque nuts on cable clamps according to drawing 32401-XX supplied with Mount Kit for Electric Vibrators.
- e. Trim loose ends of wire cable.

***Nut and cap screw torque***

After removing any nuts or cap screws from vibrator assembly, re-install to the torque values specified in Table II.

**Table II. Vibrator Nut and Cap Screw Torque Requirements**

Cap Screws	ft/lb (kgm)	Shaft Nuts	ft/lb (kgm)	Terminal Block Nuts	ft/lb (kgm)
M6	7 (1)	M13x1	22 (3)	M4	0.87 (0.12)
M8	16.5 (2.3)	M15x1	36 (5)	M5	1.45 (0.20)
M10	35 (4.8)	M20x1	72 (10)	M6	2.17 (0.30)
M12	58 (8)	M25x1.5	123 (17)	M8	4.70 (0.65)
M14	94 (13)	M30x1.5	246 (34)	M10	9.80 (1.35)
M16	137 (19)	M45x1.5	360 (50)		
M18	195 (27)				
M20	275 (38)				

***Connecting power to vibrator***



**Wire vibrator in accordance with National Electrical Code Article 430. Have wiring installed by a qualified electrician only.**

1. Find wiring diagram number for your vibrator on vibrator nameplate.



**Before running cord to vibrator, make sure cord voltage rating equals or exceeds the voltage at which you will be operating the vibrator. It must have a minimum temperature rating of 221°F (105°C) and a diameter as shown in Table III. If wire is not proper diameter, cord grip will not tighten properly and vibrator could be damaged by moisture or material getting inside wiring compartment. If cord is damaged, it could short power supply or short to ground causing damage to vibrator.**

2. Table III provides information on securing the electric vibrator cord grip when installing power supply and thermistor circuit cords. The frame size of the electric vibrator will define the size of the cord grip. Each cord grip is designed for a specific cord diameter range. When installed at the factory, the cord used is noted in Table III.

**IMPORTANT**

See Figure 5. The compression nut must be tightened to a position that will provide proper strain relief for the cord. If the compression nut is not tight enough, the electrical connections may be stressed. If the compression nut is too tight, the cord may be damaged. When using a factory cord, tighten the compression nut to a position that meets the specified “Distance Between Flats.”

**Table III. Cord Grip Specifications**

Frame Size	Size	Part No.	Suitable Cord Diameter Range in. (mm)	Cord Provided by Factory		
				Size	Nominal Diameter, in.	Distance Between Flats, in.
00	1/2 NPT	194995	.17-.45 (4-12)	18/4	0.402	1/8 to 3/16
10	1/2 NPT	194851	.17-.45 (4-12)	18/4	0.402	1/8 to 3/16
20	1/2 NPT	194851	.17-.45 (4-12)	18/4	0.402	1/8 to 3/16
30-50	1/2 NPT	823002	.56-.63 (14-16)	14/4	0.575	1/8 to 3/16
90-95	3/4 NPT	823001	.51-.71 (13-18)	10/4	0.705	1/16 to 1/8
97-105	1 NPT	820003	.70-.85 (18-22)	8/4	0.807	1/8 to 3/16

Model	Size	Part No.	Suitable Cord Diameter Range in. (mm)	Cord Provided by Factory		
				Size	Nominal Diameter, in.	Distance Between Flats, in.
MB36-3000	1/2 NPT	194856	.38-.50 (10-13)	16/4	0.425	1/8 to 3/16

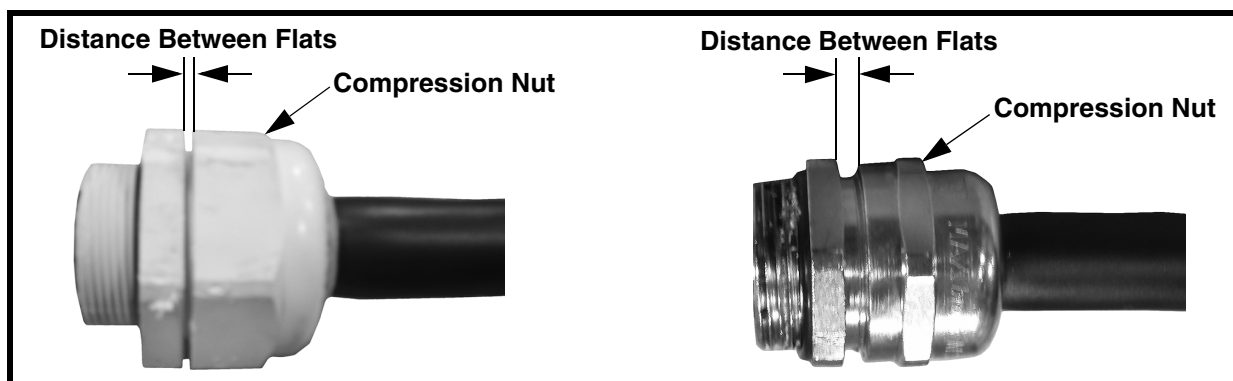
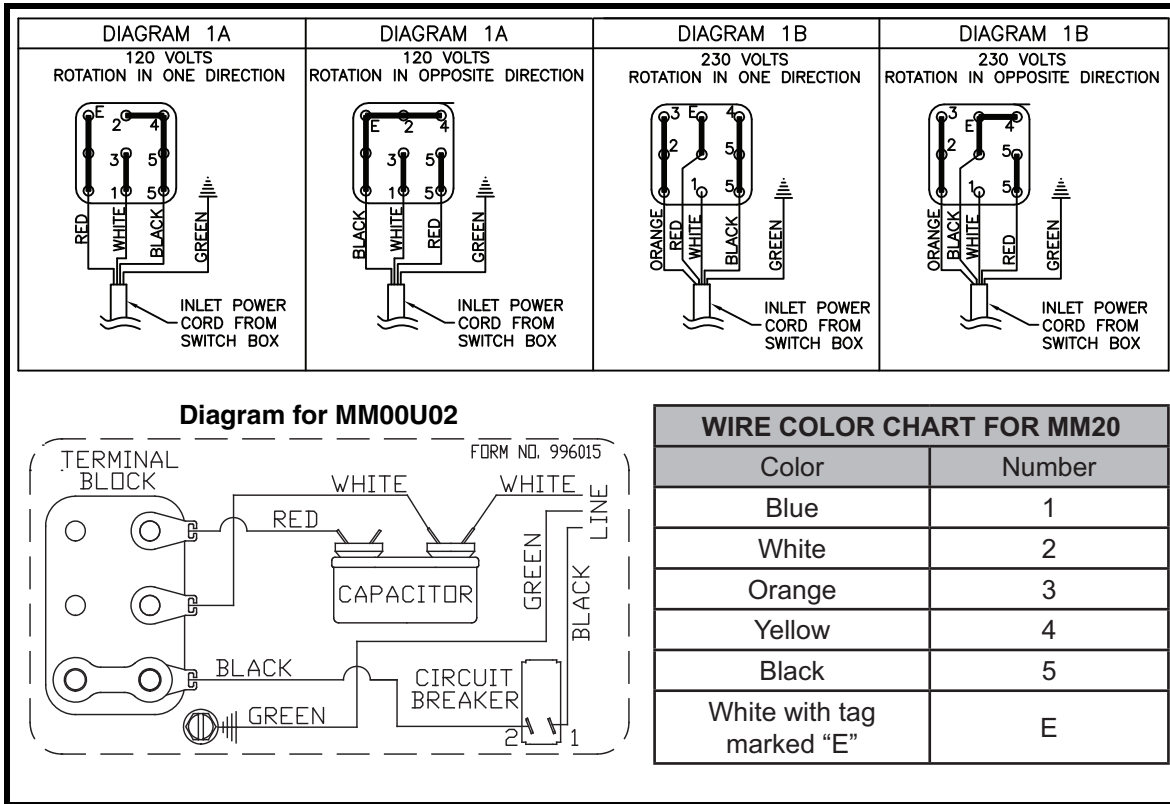

**Figure 5. Cord Grip Installation**

**IMPORTANT**

When wiring vibrator, leave slack in electrical cable so that cable does not become taut during vibration cycle and cause stress on wire connections. On applications where moisture is present, leave enough slack in power cable to prevent moisture from running down cable into vibrator.

- Wire vibrator according to appropriate wiring diagram inside terminal box or see Figure 6 or 7. **Use closed loop wire connectors only.**



**Figure 6. Single Phase Wiring Diagrams**

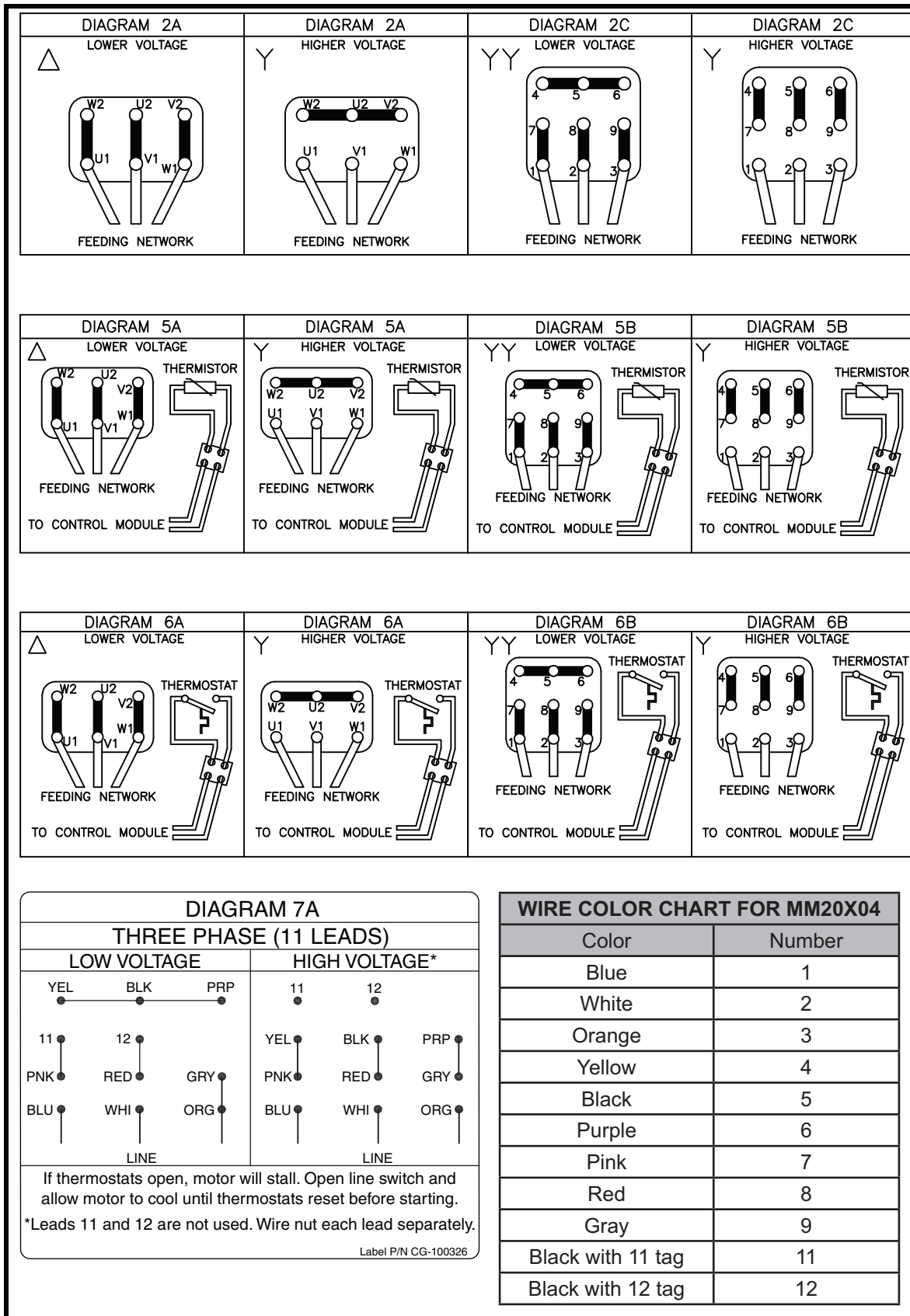

**Figure 7. Three Phase Wiring Diagrams**

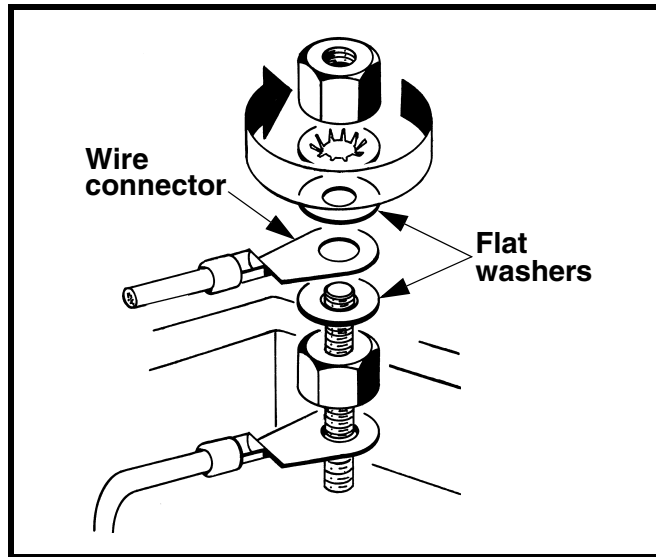

**Figure 8. Installing Wire Connector**

4. Install wire connector between the two flat washers. See Figure 8.

**⚠ WARNING**

**Vibrator must be grounded using the power supply ground wire (or other if specified in the NEC). Failure to properly ground vibrator can cause severe injury or death.**

5. Connect power supply ground wire (or other if specified in the NEC) to ground vibrator terminal. Use closed loop wire connector only.
6. Reassemble wiring cover, o-ring, and rubber compression block(s), taking care not to pinch the o-ring. Tighten cord grip around supply line(s).



*Installing  
overload, short-  
circuit, and  
ground-fault  
protection*

**⚠ CAUTION**

**Install overload protection for vibrator. If vibrator is not protected from overload, vibrator can be destroyed and warranty will be void. Determine size of overload protection according to NEC Article 430 and have it installed by a qualified electrician only.**

1. Determine overload, short-circuit, and ground-fault protection according to NEC Article 430.
2. Have qualified electrician install overload, short-circuit, and ground-fault protection.
3. If overload trips during operation, fix problem before resetting.

**⚠ CAUTION**

**For equipment using two vibrators, the two motors must be electrically interlocked. If using a single contactor, each motor must be provided with separate overload protection. The motor control circuit must be arranged so that if one motor becomes de-energized, the other motor will automatically and immediately become de-energized. Failure to properly interlock motors could result in severe damage to equipment if one vibrator fails.**

4. If using two vibrators, interlock the two vibrator motors and install separate overload protection for each.

## After Installing Vibrator

---

### *Checking shaft rotation*

#### **IMPORTANT**

Read entire section before beginning work.

1. Remove cap screws, washers, and vibrator weight covers.

#### **CAUTION**

**DO NOT run vibrator with eccentric weights removed. Running vibrator with eccentric weights removed will damage bearings.**

#### **WARNING**

**When checking shaft rotation with weight cover removed, keep hands away from swinging weights. Weights can crush fingers.**

2. Start vibrator for one second, then stop.
3. Observe direction of motor rotation. If motor is not rotating in correct direction, lockout / tagout / blockout / testout energy source and reverse rotation. To reverse rotation of three-phase vibrator, reverse any two of the three power supply wires.
4. Replace weight cover, taking care not to pinch o-ring.

### *Adjusting eccentric weights for 00–10 frame*

#### **NOTE**

Table IV shows the force output for each weight configuration.

#### **IMPORTANT**

**For the most efficient operation, vibrator eccentric weights should be adjusted to the lowest force setting required to move the material. This will increase vibrator life and reduce energy costs.**

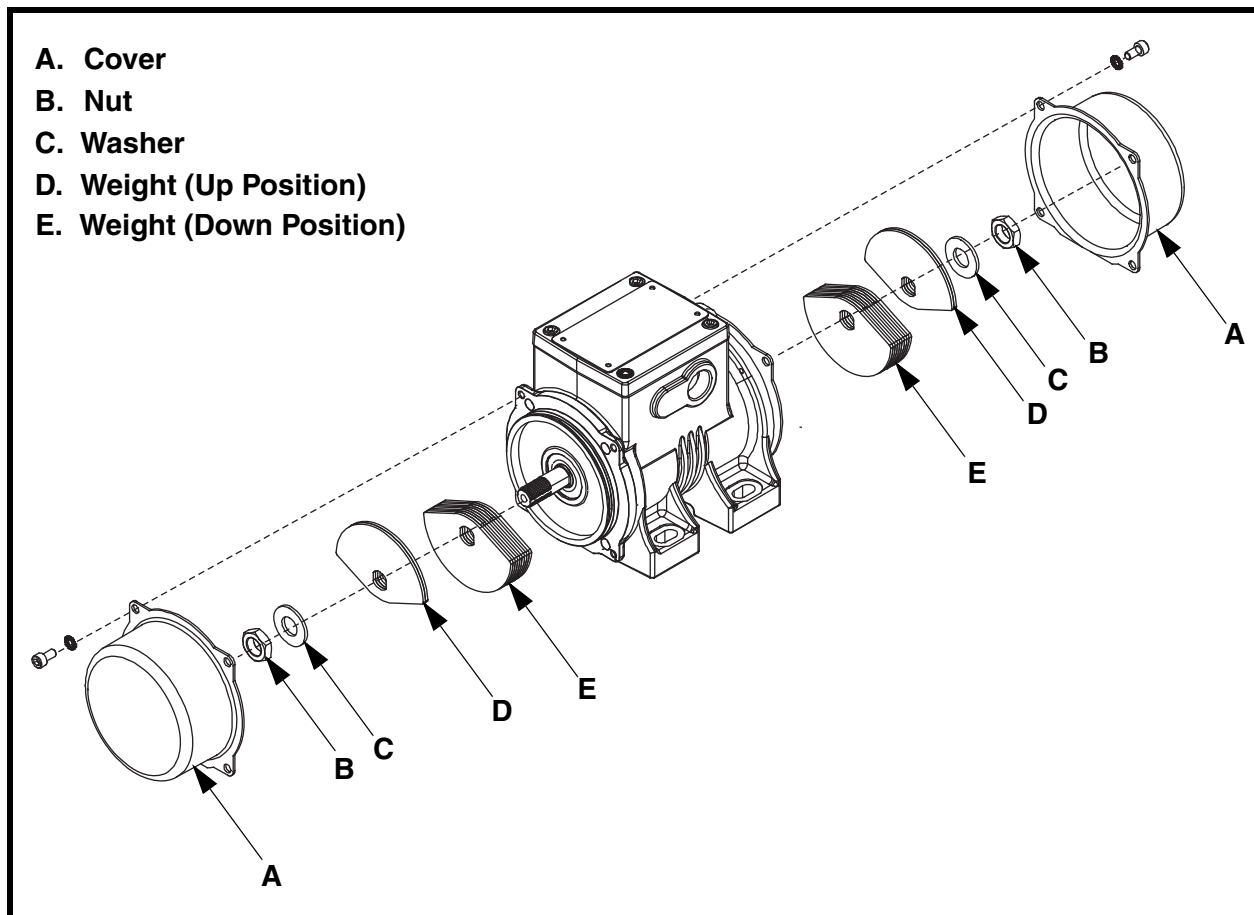

**Figure 9. Adjusting Eccentric Weights**

**Table IV. Eccentric Weight Settings**

Model MM00C02 & MM00U02		
Lbs of Force (60 Hz)	Qty of Weights in Up Position	Qty of Weights in Down Position
33	5	6
99	4	7
166	3	8
232*	2*	9*
298	1	10
380	0	11

*\*Factory Setting*

Model MM10C02 & MM10U02		
Lbs of Force (60 Hz)	Qty of Weights in Up Position	Qty of Weights in Down Position
149	5	8
248	4	9
348*	3*	10*
448	2	11
547	1	12
647	0	13

\*Factory Setting

Model MM10C04 & MM10U04		
Lbs of Force (60 Hz)	Qty of Weights in Up Position	Qty of Weights in Down Position
68	6	8
135	5	9
203	4	10
270*	3*	11*
338	2	12
405	1	13
473	0	14

\*Factory Setting

Model MM10A02 & MM10U02		
Lbs of Force (50 Hz)	Qty of Weights in Up Position	Qty of Weights in Down Position
138	8	12
208	7	13
276	6	14
345	5	15
414*	4*	16*
483	3	17
552	2	18
621	1	19
691	0	20

\*Factory Setting

Model MM10A04 & MM10U04		
Lbs of Force (50 Hz)	Qty of Weights in Up Position	Qty of Weights in Down Position
94	8	12
141	7	13
188	6	14
235	5	15
282*	4*	16*
329	3	17
375	2	18
422	1	19
470	0	20

\*Factory Setting



**⚠ WARNING**

**Before adjusting weights, turn off and lock out/tag out energy source to vibrator.**

1. Turn off and lock out/tag out energy source to vibrator according to ANSI standards (see “References”).
2. Remove weight cover (A).
3. Remove nut (B) and washer (C).
4. Adjust weights according to Table IV.
5. Check o-rings for damage. Replace if damaged.

**CAUTION**

Do not operate vibrator with weight covers removed. Dust accumulating around vibrator shaft could cause unit to fail.

- Replace weight covers.

**CAUTION**

Adjust both sets of eccentric weights to same setting (mirror images) or force output will be uneven.

- Repeat steps 1 through 6 for second set of weights. Set both sets of weights the same so they are mirror images.

**NOTE**

All Martin® Electric Vibrators 20–105 frame have one set of eccentric weights on each end of shaft.

The percentage increments on the weight or on the weight adjustment disks are percentages of the total force pounds listed on the nameplate. For example, if the nameplate shows 8340 lb, setting the weights to 50% would produce 4170 pounds of force.

**IMPORTANT**

For the most efficient operation, vibrator eccentric weights should be adjusted to the lowest force setting required to move the material. This will increase vibrator life and reduce energy costs.

**WARNING**

Before adjusting eccentric weights, turn off and lockout / tagout / blockout / testout energy source to vibrator.

**NOTE**

The fixed weight is keyed to the shaft. The adjustable weight rotates around the shaft.

- Turn off and lockout / tagout / blockout / testout energy source to vibrator according to ANSI standards (see “References”).
- Remove weight cover.
- Loosen socket head cap screw (A, Figure 10) so adjustable weight (B) will rotate around shaft (C).

### *Adjusting eccentric weights for 20–105 frame*

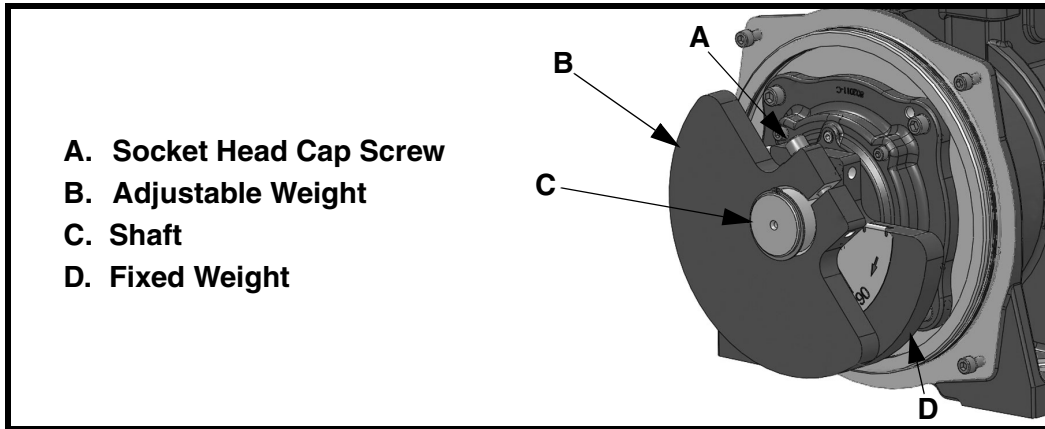

Figure 10. Adjusting Eccentric Weights

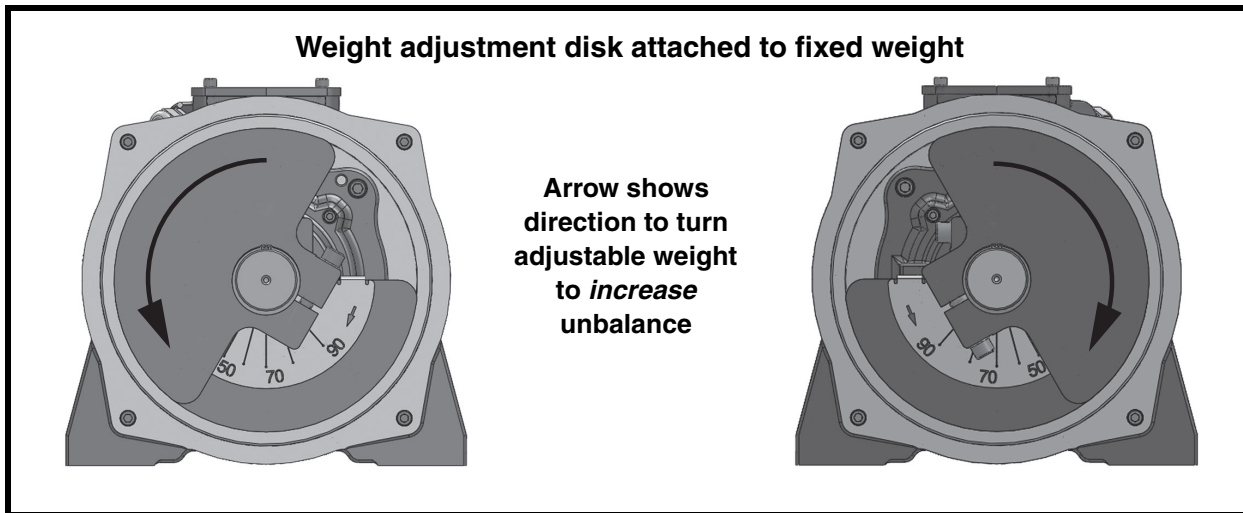

Figure 11. Example of Adjustable Weights Set at 50%

4. See Figure 11. Rotate adjustable eccentric weight to proper setting. To produce more force, move weight to higher setting (i.e., higher number). When set, tighten socket head cap screw according to Table II.
5. Check o-rings for damage. Replace if damaged.

**CAUTION**

Do not operate vibrator with weight covers removed. Dust accumulating around vibrator shaft could cause unit to fail.

6. Replace weight covers.

**⚠ CAUTION**

Adjust both sets of eccentric weights to same setting number (mirror images) or force output will be uneven.

7. Repeat steps 2 through 5 for second set of weights. Set both sets of weights to same setting number so they are mirror images, as shown in Figure 12.

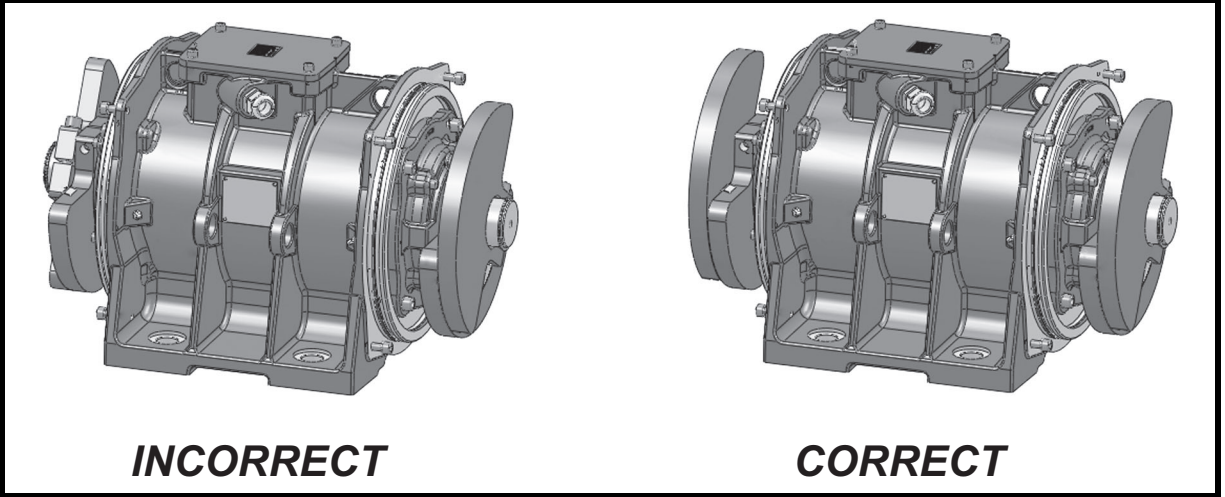

Figure 12. Setting Sets of Eccentric Weights to Mirror Images

***Initial start up/  
checking line  
current***

1. Close power supply disconnect switch and allow motor(s) to operate for 10 to 20 minutes.
2. If vibrator makes unusual or excessive noise, make sure mounting bolts are tight and mount welds are not damaged.

**⚠ WARNING**

Vibrator may produce loud noise during operation when mounted on structure. See OSHA 1910.95 for guidelines. If required, wear ear protection to avoid impairment or loss of hearing.

3. Check decibel level of vibrator noise during operation. See OSHA 1910.95 to determine whether noise exceeds safe limits. If required, wear ear protection to avoid impairment or loss of hearing.

**⚠ CAUTION**

Do not allow motor current to exceed nameplate rating. If vibrator is operated continuously with line current above nameplate rating, vibrator can be damaged.

4. After a few hours of operation, check each line current. If reading is higher than nameplate rating, reduce eccentric weight setting, stiffen vibrator mount, or move vibrator to more rigid location. After making adjustments, check line current again to ensure line current does not exceed nameplate rating.

*Variable  
frequency inverter*

5. After first 8 hours of use and periodically thereafter, check mounting bolts and tighten if necessary.

**⚠ CAUTION**

**All motors can be operated using a variable frequency inverter. NEVER operate the motor at a frequency higher than that specified on the nameplate. Damage to vibrator can result.**

Do not operate vibrator motor at frequency higher than specified on nameplate. Throughout frequency range, verify that each line current does not exceed current rating on nameplate. If reading is higher than nameplate, consult inverter manual. If necessary, adjust inverter, reduce eccentric weight setting, stiffen vibrator mount location, or move vibrator to more rigid location. After making adjustment, check line current again to ensure line current does not exceed nameplate rating.



## IMPORTANT

Read entire section before beginning work. Allow vibrator to cool to ambient temperature before working on it.

## NOTE

All vibrators are lubricated at the factory.

## ⚠ CAUTION

Use only prescribed grease in vibrator. If a different grease is used, vibrator can be damaged and warranty will be void.

Use only prescribed amount of grease to lubricate vibrator. Too much grease will cause bearings to overheat and result in premature bearing failure.

### *Lubricating vibrator*

1. See Table V for lubrication schedule and amount of grease required for your vibrator.

## ⚠ CAUTION

For 3600 rpm machines operating continuously or for long periods of time, reduce lubrication time and amount as shown in step 2. Failure to do so could run bearings dry and destroy unit.

2. If motor housing temperatures exceed 194°F (90°C), cut lubrication time and amount in half for every 18°F (10°C) increment that meets or exceeds 194°F (90°C). For example, if MM9-1440 motor housing temperature is 204°F (96°C), use 4.5 grams of grease per bearing every 1000 hours. (Maximum bearing temperature allowed is 248°F [120°C].) For motor housing temperatures above 212°F (100°C), consult Martin Engineering or a representative.

## NOTE

Kluber grease may be purchased from Martin Engineering by calling 800-544-2947.

3. For MM9, MM12, and MM18 model vibrators, lubricate frame size 35 and larger vibrators with Kluber Staburags NBU 8EP grease only. For MM36 and MB36 model vibrators, lubricate frame size 35 and larger vibrators with Isoflex NBU 15 grease only. Lubricate as follows:
  - a. Clean vibrator case around grease fitting.
  - b. Insert grease gun onto grease fitting. Add grease.

**Table V. Lubrication Schedule For Each Bearing  
(00–30 Frames are Lubricated for Life)**

<b>Model</b>	<b>Frame Size</b>	<b>Interval Hours</b>	<b>Kluber Grease Type</b>	<b>Amount Grams</b>
<b>M Series - 3600 RPM</b>				
MM36-2510	35	2000	Isoflex NBU 15	7
MB36-3000	35	2000	Isoflex NBU 15	7
MM36-3500	35	2000	Isoflex NBU 15	7
MM36-3280	50	2000	Isoflex NBU 15	16
MM36-4100	50	2000	Isoflex NBU 15	16
MM36-4910	50	2000	Isoflex NBU 15	16
<b>M Series - 1800 RPM</b>				
MM18-2150	35	2000	Staburags NBU 8EP	7
MM18-3190	40	2000	Staburags NBU 8EP	16
MM18-3870	50	2000	Staburags NBU 8EP	16
MM18-4500	50	2000	Staburags NBU 8EP	16
MM18-5500	50	2000	Staburags NBU 8EP	16
MM18-14500	90	1000	Staburags NBU 8EP	60
MM18-17600	95	1000	Staburags NBU 8EP	80
MM18-19700	97	1000	Staburags NBU 8EP	90
MM18-25300	100	1000	Staburags NBU 8EP	130
<b>M Series - 1200 RPM</b>				
MM12-1630	35	2000	Staburags NBU 8EP	7
MM12-1990	40	2000	Staburags NBU 8EP	9
MM12-2530	50	2000	Staburags NBU 8EP	16
MM12-3100	50	2000	Staburags NBU 8EP	16
MM12-11700	90	2000	Staburags NBU 8EP	50
MM12-14400	90	2000	Staburags NBU 8EP	50
MM12-17600	95	2000	Staburags NBU 8EP	80
MM12-14200	97	1000	Staburags NBU 8EP	90
MM12-20100	97	1000	Staburags NBU 8EP	90
MM12-26500	100	1000	Staburags NBU 8EP	130
MM12-31000	105	1000	Staburags NBU 8EP	150
MM12-37000	105	1000	Staburags NBU 8EP	180
<b>M Series - 900 RPM</b>				
MM9-910	35	2000	Staburags NBU 8EP	7
MM9-1440	40	2000	Staburags NBU 8EP	9
MM9-2020	50	2000	Staburags NBU 8EP	16
MM9-9310	90	2000	Staburags NBU 8EP	50
MM9-11700	90	2000	Staburags NBU 8EP	50
MM9-14400	95	2000	Staburags NBU 8EP	80
MM9-15500	95	2000	Staburags NBU 8EP	80
MM9-14500	97	1000	Staburags NBU 8EP	90
MM9-21900	97	1000	Staburags NBU 8EP	90
MM9-24800	100	1000	Staburags NBU 8EP	130
MM9-31000	105	1000	Staburags NBU 8EP	150
MM9-38000	105	1000	Staburags NBU 8EP	180

### *Repairing motor and replacing bearings*

#### **⚠ CAUTION**

**Do not attempt to repair vibrator motor or replace bearings yourself. If you attempt to do so during the warranty period, the warranty may be void.**

If vibrator motor needs repair or if bearings need to be replaced, call Martin Engineering at **800-544-2947** for instructions.

### *Inspecting vibrator*

At least quarterly, inspect vibrator, cable, and connections as follows:

#### **⚠ WARNING**

**Before inspecting vibrator, turn off and lockout / tagout / blockout / testout energy source to vibrator.**

1. Turn off and lockout / tagout / blockout / testout energy source to vibrator according to ANSI standards (see “References”).
2. Inspect weight covers for cracks and check cap screws for tightness.
3. Inspect cable for damage including cuts and abrasions. Replace if damaged.
4. Inspect ground connection. Make sure ground connection to motor enclosure does not exceed 0.1 ohm. Ensure screw on ground terminal is tightened to proper torque (see Table II).
5. Make sure all nuts on connections on terminal block are tightened to proper torque. Do not over tighten (see Table II).

# Part Numbers

This section provides model numbers and part numbers for the M Series Martin® Electric Vibrators and related equipment. Please call Martin Engineering at **800-544-2947** for replacement parts.

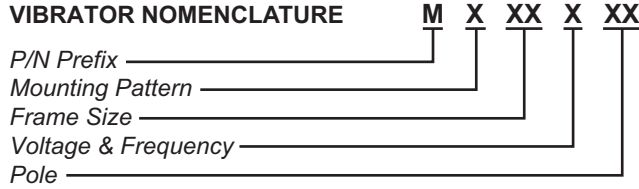

**MOUNTING PATTERN**

- M:** Martin®
- C:** Cougar®  
(30–50,90/95 Frame only)
- I:** Invicta
- V:** Vimarc®
- U:** Uras®
- B:** Bosch®

**VOLTAGE & FREQUENCY**

- A:** 220-240/380-415V 50Hz 3PH
- C:** 220-240/440-480V 60Hz 3PH
- F:** 330/575-600V 60Hz 3PH
- U:** 115V 60Hz 1PH
- W:** 230V 60Hz 1PH

**Table VI. Martin® Electric Vibrator Model Numbers and Part Numbers**

00 Frame		10 Frame		20 Frame		30 Frame	
Model	Part No.	Model	Part No.	Model	Part No.	Model	Part No.
MM36-380	MM00X02	MM18-660	MM10X04	MM18-1000	MM20X04	MM9-590	MX30X08
		MM36-660	MM10X02	MM36-1000	MM20X02	MM12-760	MX30X06
						MM18-1690	MX30X04
						MM36-1680	MX30X02

35,36,37 Frame		40 Frame		50,51,52 Frame		90, 91 Frame	
Model	Part No.	Model	Part No.	Model	Part No.	Model	Part No.
MM9-910	MX35X08	MM9-1400	MX40X08	MM9-2020	MX50X08	MM9-9310	MX90X08
MM12-1630	MX35X06	MM12-1990	MX40X06	MM12-2530	MX50X06	MM9-11700	MX91X08
MM12-2300	MX36X06	MM18-3190	MX40X04	MM12-3100	MX51X06	MM12-11700	MX90X06
MM18-2150	MX35X04			MM18-3870	MX50X04	MM12-14400	MX91X06
MM36-2510	MX35X02			MM18-4500	MX51X04	MM18-14500	MX90X04
MI36-2900	MI36X02			MM18-5500	MX52X04		
MB36-3000	MB35X02			MM36-3280	MX50X02		
MM36-3500	MX37X02			MM36-4100	MX51X02		
				MM36-4910	MX52X02		

95, 96 Frame		97, 100 Frame		105,106 Frame	
Model	Part No.	Model	Part No.	Model	Part No.
MM9-14400	MX95X08	MM9-21900	MX97X08	MM9-31000	MX105X08
MM9-15500	MX96X08	MM9-24800	MX100X08	MM9-38000	MX106X08
MM12-17600	MX95X06	MM12-20100	MX97X06	MM12-31000	MX105X06
MM18-17600	MX95X04	MM12-26500	MX100X06	MM12-37000	MX106X06
		MM18-19700	MX97X04		
		MM18-25300	MX100X04		

***Vibrator mounts***

**W-beam Mount:** P/N 29757-XX. XX indicates vibrator frame size for MM and MC models.

**Mount Kit for Electric Vibrators:** P/N 32401-XX. (Kit includes W-beam Mount, mounting hardware, and Martin® BBAC Cable Kit.)

Model	Frame Size	Part No.
MM	00	32401-01
	10	32401-10
	20	32401-20
	30/35	32401-30
	40/50	32401-50

Model	Frame Size	Part No.
MC	30/35	32401-B2
	40/50	32401-B3

***Miscellaneous***

**Martin® BBAC Cable Kit:** P/N 32271. (Kit includes D-ring, cable, cable clamps, and clamp hardware.)



**Appendix**  
**Martin® Electric Vibrator Dimensions**

Martin® Electric Vibrator Dimensions (in. [mm])\*

Frame Size	Pole	A	B	C	D	E	F	Foot Holes		H	I
								ØG	No.		
00	2	8.64 (220)	5.3 (135)	4.92 (125)	2.36-2.95 (60-75)	4.17 (106)	0.65 (16)	0.35 (9)	4	2.03 (52)	4.74 (120)
10	2,4	11.77 (299)	7.14 (181)	5.91 (150)	3.54 (90)	4.92 (125)	0.75 (19)	0.55 (14)	4	3.15 (80)	7.29 (185)
20	2,4	11.85 (301)	8.36 (212)	7.7 (195)	4.13-5 (105-127)	5.51-6 (140-152)	0.75 (19)	0.56 (14)	4	3.89 (99)	8.39 (213)
30	2, 4, 8	14.92 (379)	9.41 (239)	8.43 (214)	4.72 (120)	6.69 (170)	2.17 (55)	.669 (17)	4	4.53 (115)	6.88 (175)
	6	17.91 (455)	9.41 (239)	8.43 (214)	4.72 (120)	6.69 (170)	2.17 (55)	.669 (17)	4	4.53 (115)	6.88 (175)
35	2, 4, 6	14.92 (379)	9.41 (239)	8.43 (214)	4.72 (120)	6.69 (170)	2.17 (55)	.669 (17)	4	4.53 (115)	6.88 (175)
	8	17.91 (455)	9.41 (239)	8.43 (214)	4.72 (120)	6.69 (170)	2.17 (55)	.669 (17)	4	4.53 (115)	6.88 (175)
40	4, 6, 8	19.57 (497)	10.22 (260)	9.84 (250)	5.51 (140)	7.48 (190)	2.01 (51)	.669 (17)	4	5.02 (128)	7.87 (200)
50	2	16.42 (417)	10.22 (260)	9.84 (250)	5.51 (140)	7.48 (190)	2.01 (51)	.669 (17)	4	5.02 (128)	7.87 (200)
	4, 6, 8	19.57 (497)	10.22 (260)	9.84 (250)	5.51 (140)	7.48 (190)	2.01 (51)	.669 (17)	4	5.02 (128)	7.87 (200)
51	2	16.42 (417)	10.22 (260)	9.84 (250)	5.51 (140)	7.48 (190)	2.01 (51)	.669 (17)	4	5.02 (128)	7.87 (200)
	4, 6	19.57 (497)	10.22 (260)	9.84 (250)	5.51 (140)	7.48 (190)	2.01 (51)	.669 (17)	4	5.02 (128)	7.87 (200)
52	2	16.42 (417)	10.22 (260)	9.84 (250)	5.51 (140)	7.48 (190)	2.01 (51)	.669 (17)	4	5.02 (128)	7.87 (200)
90	4	27.28 (693)	15.24 (387)	15.91 (404)	7.87 (200)	12.60 (320)	1.13 (29)	1.10 (28)	4	7.48 (190)	13.79 (350)
	6, 8	35.28 (896)	15.24 (387)	16.14 (410)	7.87 (200)	12.60 (320)	1.13 (29)	1.18 (30)	4	7.48 (190)	13.79 (350)
91	6, 8	35.28 (896)	15.24 (387)	16.14 (410)	7.87 (200)	12.60 (320)	1.13 (29)	1.18 (30)	4	7.48 (190)	13.79 (350)
	4	27.28 (693)	15.24 (387)	16.14 (410)	7.87 (200)	12.60 (320)	1.13 (29)	1.18 (30)	4	7.48 (190)	13.79 (350)
95	6, 8	35.28 (896)	15.24 (387)	16.14 (410)	7.87 (200)	12.60 (320)	1.13 (29)	1.18 (30)	4	7.48 (190)	13.79 (350)
	4	27.28 (693)	15.24 (387)	16.14 (410)	7.87 (200)	12.60 (320)	1.13 (29)	1.18 (30)	4	7.48 (190)	13.79 (350)
96	6, 8	35.28 (896)	15.24 (387)	16.14 (410)	7.87 (200)	12.60 (320)	1.13 (29)	1.18 (30)	4	7.48 (190)	13.79 (350)
	4	35.28 (896)	15.24 (387)	16.14 (410)	7.87 (200)	12.60 (320)	1.13 (29)	1.18 (30)	4	7.48 (190)	13.55 (344)
97	4,6	33.82 (859)	18.70 (475)	18.11 (460)	4.92 (125)	14.96 (380)	1.50 (38)	1.54 (39)	6	9.17 (233)	17.60 (447)
	8	37.76 (959)	18.70 (475)	18.11 (460)	4.92 (125)	14.96 (380)	1.50 (38)	1.54 (39)	6	9.17 (233)	17.60 (447)
100	4	33.82 (859)	18.70 (475)	20.94 (532)	5.51 (140)	17.32 (440)	1.42 (36)	1.77 (45)	6	9.17 (233)	17.60 (447)
	6, 8	37.76 (959)	18.70 (475)	20.94 (532)	5.51 (140)	17.32 (440)	1.42 (36)	1.77 (45)	6	9.17 (233)	17.60 (447)

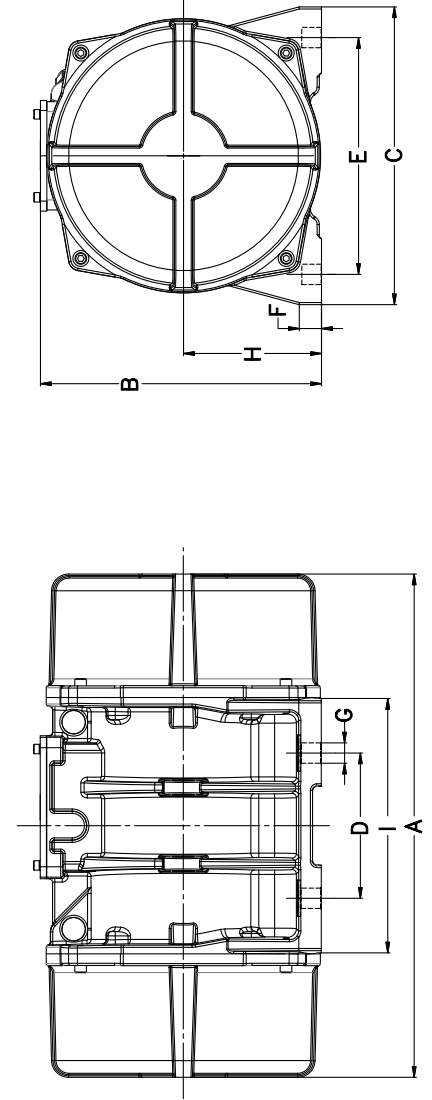



**Martin® Electric Vibrator Cougar Dimensions (in. [mm])\***

Frame Size	Pole	A	B	C	D	E	F	Foot Holes		H	I
								ØG	No.		
30	2, 4, 8	14.92 (379)	9.41 (239)	8.43 (214)	5.50 (140)	7.00 (178)	2.17 (55)	.669 (17)	4	4.53 (115)	6.88 (175)
	6	17.91 (455)	9.41 (239)	8.43 (214)	5.50 (140)	7.00 (178)	2.17 (55)	.669 (17)	4	4.53 (115)	6.88 (175)
35	2, 4, 6	14.92 (379)	9.41 (239)	8.43 (214)	5.50 (140)	7.00 (178)	2.17 (55)	.669 (17)	4	4.53 (115)	6.88 (175)
	8	17.91 (455)	9.41 (239)	8.43 (214)	5.50 (140)	7.00 (178)	2.17 (55)	.669 (17)	4	4.53 (115)	6.88 (175)
40	4, 6, 8	19.57 (497)	10.22 (260)	9.84 (250)	6.00 (152)	8.00 (203)	2.01 (51)	.669 (17)	4	5.02 (128)	7.87 (200)
	2	16.42 (417)	10.22 (260)	9.84 (250)	6.00 (152)	8.00 (203)	2.01 (51)	.669 (17)	4	5.02 (128)	7.87 (200)
50	4, 6, 8	19.57 (497)	10.22 (260)	9.84 (250)	6.00 (152)	8.00 (203)	2.01 (51)	.669 (17)	4	5.02 (128)	7.87 (200)
	2	16.42 (417)	10.22 (260)	9.84 (250)	6.00 (152)	8.00 (203)	2.01 (51)	.669 (17)	4	5.02 (128)	7.87 (200)
51	4, 6	19.57 (497)	10.22 (260)	9.84 (250)	6.00 (152)	8.00 (203)	2.01 (51)	.669 (17)	4	5.02 (128)	7.87 (200)
	2	16.42 (417)	10.22 (260)	9.84 (250)	6.00 (152)	8.00 (203)	2.01 (51)	.669 (17)	4	5.02 (128)	7.87 (200)

**Martin® Electric Vibrator Bosch Dimensions (in. [mm])\***

Frame Size	Pole	A	B	C	D	E	F	Foot Holes		H	I
								ØG	No.		
35	2	14.37 (365)	8.74 (222)	9.84 (250)	3.937 (100)	7.874 (200)	4.961 (126)	.669 (17)	4	3.54 (90)	6.30 (160)

**Martin® Electric Vibrator Invicta Dimensions (in. [mm])\***

Frame Size	Pole	A	B	C	D	E	F	Foot Holes		H	I
								ØG	No.		
30	2, 4, 8	14.92 (379)	9.41 (239)	8.43 (214)	3.94 (100)	7.09 (180)	2.17 (55)	.669 (17)	4	4.53 (115)	6.88 (175)
	6	17.91 (455)	9.41 (239)	8.43 (214)	3.94 (100)	7.09 (180)	2.17 (55)	.669 (17)	4	4.53 (115)	6.88 (175)
35	2, 4, 6	14.92 (379)	9.41 (239)	8.43 (214)	3.94 (100)	7.09 (180)	2.17 (55)	.669 (17)	4	4.53 (115)	6.88 (175)
	8	17.91 (455)	9.41 (239)	8.43 (214)	3.94 (100)	7.09 (180)	2.17 (55)	.669 (17)	4	4.53 (115)	6.88 (175)
40	4, 6, 8	19.57 (497)	10.22 (260)	9.84 (250)	5.91 (150)	7.28 (185)	2.01 (51)	.669 (17)	4	5.02 (128)	7.87 (200)
	2	16.42 (417)	10.22 (260)	9.84 (250)	5.91 (150)	7.28 (185)	2.01 (51)	.669 (17)	4	5.02 (128)	7.87 (200)
50	4, 6, 8	19.57 (497)	10.22 (260)	9.84 (250)	5.91 (150)	7.28 (185)	2.01 (51)	.669 (17)	4	5.02 (128)	7.87 (200)
	2	16.42 (417)	10.22 (260)	9.84 (250)	5.91 (150)	7.28 (185)	2.01 (51)	.669 (17)	4	5.02 (128)	7.87 (200)
51	4, 6	19.57 (497)	10.22 (260)	9.84 (250)	5.91 (150)	7.28 (185)	2.01 (51)	.669 (17)	4	5.02 (128)	7.87 (200)
	2	16.42 (417)	10.22 (260)	9.84 (250)	5.91 (150)	7.28 (185)	2.01 (51)	.669 (17)	4	5.02 (128)	7.87 (200)
52	4, 6	16.42 (417)	10.22 (260)	9.84 (250)	5.91 (150)	7.28 (185)	2.01 (51)	.669 (17)	4	5.02 (128)	7.87 (200)
	2	16.42 (417)	10.22 (260)	9.84 (250)	5.91 (150)	7.28 (185)	2.01 (51)	.669 (17)	4	5.02 (128)	7.87 (200)
97	4, 6	33.82 (859)	18.70 (475)	18.11 (460)	4.63 (117.5)	15.51 (394)	1.50 (38)	1.22 (31)	6	9.17 (233)	17.60 (447)
	8	37.76 (959)	18.70 (475)	18.11 (460)	4.63 (117.5)	15.51 (394)	1.50 (38)	1.22 (31)	6	9.17 (233)	17.60 (447)

**Martin® Electric Vibrator Vimarc Dimensions (in. [mm])\***

Frame Size	Pole	A	B	C	D	E	F	Foot Holes		H	I
								ØG	No.		
40	4, 6, 8	19.57 (497)	10.22 (260)	9.84 (250)	5.51 (140)	6.69 (170)	2.01 (51)	.669 (17)	4	5.02 (128)	7.87 (200)
	2	16.42 (417)	10.22 (260)	9.84 (250)	5.51 (140)	6.69 (170)	2.01 (51)	.669 (17)	4	5.02 (128)	7.87 (200)
50	4, 6, 8	19.57 (497)	10.22 (260)	9.84 (250)	5.51 (140)	6.69 (170)	2.01 (51)	.669 (17)	4	5.02 (128)	7.87 (200)
	2	16.42 (417)	10.22 (260)	9.84 (250)	5.51 (140)	6.69 (170)	2.01 (51)	.669 (17)	4	5.02 (128)	7.87 (200)
51	4, 6	19.57 (497)	10.22 (260)	9.84 (250)	5.51 (140)	6.69 (170)	2.01 (51)	.669 (17)	4	5.02 (128)	7.87 (200)
	2	16.42 (417)	10.22 (260)	9.84 (250)	5.51 (140)	6.69 (170)	2.01 (51)	.669 (17)	4	5.02 (128)	7.87 (200)

**Martin® Electric Vibrator Uras Dimensions (in. [mm])\***

Frame Size	Pole	A	B	C	D	E	F	Foot Holes		H	I
								ØG	No.		
90	4	27.28 (693)	15.24 (387)	15.91 (404)	8.66 (220)	13.78 (350)	1.09 (28)	1.50 (38)	4	7.48 (190)	13.79 (350)
	6	35.28 (896)	15.24 (387)	16.14 (410)	8.66 (220)	13.78 (350)	1.09 (28)	1.57 (40)	4	7.48 (190)	13.79 (350)
	8	35.28 (896)	15.24 (387)	16.14 (410)	8.66 (220)	13.78 (350)	1.09 (28)	1.50 (38)	4	7.48 (190)	13.79 (350)
91	6	35.28 (896)	15.24 (387)	16.14 (410)	8.66 (220)	13.78 (350)	1.09 (28)	1.57 (40)	4	7.48 (190)	13.79 (350)
	8	35.28 (896)	15.24 (387)	16.14 (410)	8.66 (220)	13.78 (350)	1.09 (28)	1.50 (38)	4	7.48 (190)	13.79 (350)
95	4	27.28 (693)	15.24 (387)	16.14 (410)	8.66 (220)	13.78 (350)	1.09 (28)	1.57 (40)	4	7.48 (190)	13.79 (350)
	6, 8	35.28 (896)	15.24 (387)	16.14 (410)	8.66 (220)	13.78 (350)	1.09 (28)	1.57 (40)	4	7.48 (190)	13.79 (350)
96	8	35.28 (896)	15.24 (387)	16.14 (410)	8.66 (220)	13.78 (350)	1.09 (28)	1.10 (28)	4	7.48 (190)	13.55 (344)

*Any product, process, or technology described here may be the subject of intellectual property rights reserved by Martin Engineering Company. Trademarks or service marks designated with the ® symbol are registered with the U.S. Patent and Trademark Office and may be proprietary in one or more countries or regions. Other trademarks and service marks belonging to Martin Engineering Company in the United States and/or other countries or regions may be designated with the “TM” and “SM” symbols. Brands, trademarks, and names of other parties, who may or may not be affiliated with, connected to, or endorsed by Martin Engineering Company, are identified wherever possible. Additional information regarding Martin Engineering Company’s intellectual property can be obtained at [www.martin-eng.com/trademarks](http://www.martin-eng.com/trademarks).*

# **Problem Solved™** ***GUARANTEED!***

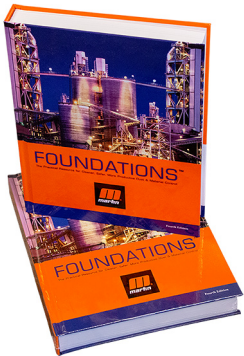

*For nearly 30 years, Martin Engineering's Foundations™ Books have taught industry personnel to operate and maintain clean and safe belt conveyors. The Foundations™ Book, fourth edition, focuses on improving belt conveyors by controlling fugitive material. "The Practical Resource for Total Dust and Material Control," is a 576-page hard cover volume that provides information of value to industries where the efficient handling of bulk materials is a key to productivity and profitability.*

*Expanding upon the book, our Foundations™ Training Program addresses the design and development of more productive belt conveyors, and is offered in three customizable seminars. Attendees gain a better understanding of conveyor safety and performance, helping to justify upgrade investments and increase profitability.*



## **Martin Engineering USA**

One Martin Place  
Neponset, IL 61345-9766 USA  
800 544 2947 or 309 852 2384  
Fax 800 814 1553  
[www.martin-eng.com](http://www.martin-eng.com)

**COMPANY WITH  
QUALITY SYSTEM  
CERTIFIED BY DNV GL  
= ISO 9001 =**