

Martin® PV Series Piston Vibrators

Martin® PV Series Piston Vibrators deliver high-impact linear force to evacuate difficult materials from storage vessels.

Martin® PV Vibrators provide an economical solution to bulk solids flow problems. Used with filtered and lubricated air, they require only minimal maintenance.



Performance Data

		Model					
		PV-1.25	PV-2	PV-2.5	PV-3	PV-4	
20 psi (1.38 bar)	Speed* VPM	2600	1400	700	575	450	
	Force	lb	35	96	147	218	350
		kg	16	44	67	99	159
	Air Consumption	cfm	—	8	9	14	28
L/sec.		—	3.78	4.25	6.61	13.21	
40 psi (2.76 bar)	Speed* VPM	3800	2000	1150	1000	525	
	Force	lb	71	190	288	424	700
		kg	32	86	131	192	318
	Air Consumption	cfm	—	16	21	30	44
L/sec.		—	7.55	9.91	14.16	20.76	
60 psi (4.14 bar)	Speed* VPM	4600	2800	1500	1300	600	
	Force	lb	106	283	430	630	1000
		kg	48	128	195	286	454
	Air Consumption	cfm	8	20	34	43	62
L/sec.		3.78	9.44	16.04	20.29	29.26	
80 psi (5.51 bar)	Speed VPM	5400	3200	1800	1400	700	
	Force	lb	142	376	571	835	1400
		kg	64	171	259	379	635
	Air Consumption	cfm	14	26	58	70	80
L/sec.		6.61	12.27	27.37	33.03	37.75	

* Speed may not be vibrations per minute (VPM), but cycles per minute.

Selection Guide

Vibrator selection is based on the vessel construction and/or the characteristics and weight of material in the sloped portion of the storage vessel.

Model	Weight of Material in Slope Portion of Vessel		Thickness of Vessel Wall		
	lb	kg	in	mm	
PV-1.25	20,000	9,070	0.07–0.125	1/16–1/8	1.5–3
PV-2	30,000	13,607	0.125–0.25	1/8–1/4	3–6
PV-2.5	40,000	18,140	0.125–0.25	1/8–1/4	3–6
PV-3	60,000	27,215	0.25–0.5	1/4–1/2	6–13

Additional PV-3 Mount

Model	P/N	Ship Wt. lb (mm)	TBM Mount P/N	Ship Wt. lb (mm)
PV-3	21287	55 (24.9)	22522	40 (18.1)

TECHNICAL DATA SHEET

Dimension—in (mm)

Models	A	B	C	D	E	F	G	H	J	K*	L*	M*
PV-1.25	5.75 (146)	4.00 (102)	4.19 (106)	0.84 (21)	1.84 (47)	4.5 (114)	0.62 (16)	1.69 (43)	—	1/4	1/2	1/4
PV-2	8.87 (225)	6.00 (152)	5.75 (146)	1.56 (40)	2.75 (70)	7.5 (190)	0.75 (19)	2.47 (63)	—	1/4	5/8	1/4
PV-2.5	11.62 (295)	7.25 (184)	6.19 (157)	6.00 (152)	3.75 (95)	9.5 (241)	1.0 (25)	3.19 (81)	3.50 (89)	1/2	3/4	—
PV-3	12.00 (305)	8.62 (219)	7.69 (195)	1.75 (44)	4.00 (102)	9.5 (241)	0.75 (19)	3.25 (83)	3.50 (89)	3/4	3/4	1/2
PV-4	12.00 (305)	11.88 (301)	7.38 (187)	6.00 (152)	4.25 (108)	10.0 (254)	2.50 (63)	4.40 (112)	4.00 (102)	3/4	—	—

* K = Inlet (NPT) M = Exhaust (NPT) L = Bolt Size

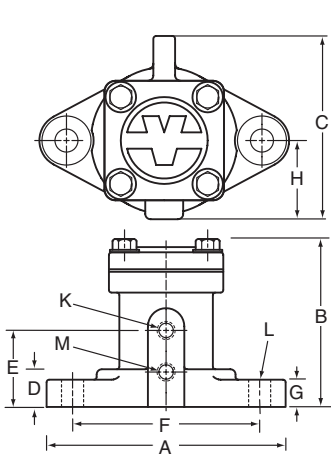

PV-1.25 and PV-2

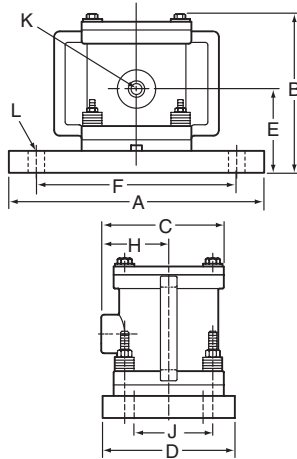

PV-2.5

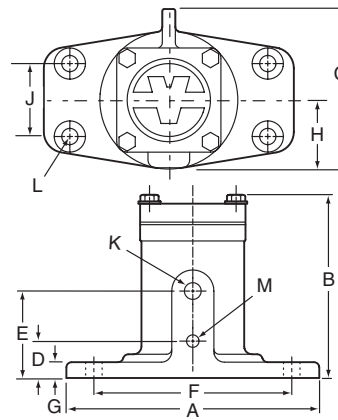

PV-3

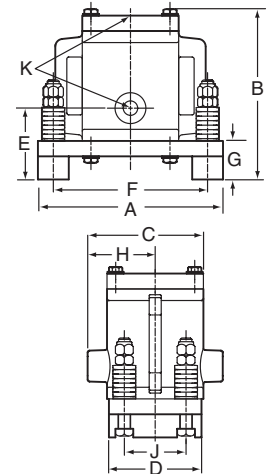

PV-4

PV Piston Vibrators			With Liner	
Model	P/N	Ship Wt. lb (kg)	P/N	Ship Wt. lb (kg)
PV-1.25	N/A	6 (2.7)	12883	6.0 (2.7)
PV-2	12889	18 (8.1)	19862	18.5 (8.4)
PV-2.5	18105	51 (20.4)	18581	52.0 (23.6)
PV-3	21287	55 (24.5)	23990	56.25 (25.5)
PV-4	17757	120 (54.4)	21035	122.5 (55.6)

ACCESSORIES

Part Number	Description
See Chart	Channel Mount
	Mounting Kit
32271	Safety Cable Assembly
39504	Control Line Kit
14824-PR	Ball Valve 1/2" NPT
14760-PR	Filter, Regulator, Lubricator Combination, 1/2" NPT
14766-PR	Air Motor Oil [qt]
38902	Pneumatic Controller/Timer - Single Circuit
38901	Pneumatic Controller/Timer - Multiple Circuit
36343-NC	Solenoid Valve 1 1/5/1/60, 1/2" NPT

Model	Channel Mount	Mounting Kit
PV-1.25	29928-01	29810
PV-2	29928-02	29811
PV-2.5	29928-05	39604
PV-3	29928-05	39604
PV-4	N/A	N/A



Martin Engineering USA

3600 Cougar Drive
Peru, IL 61354 USA
855 394 4885
Fax 800 814 1553
www.martin-eng.com

**COMPANY WITH
QUALITY SYSTEM
CERTIFIED BY DNV GL
= ISO 9001 =**

Problem Solved™ GUARANTEED!

Form No. L2733-01-07/20
© Martin Engineering Company 1998, 2020