

martin®

Martin®
Roller Tracker™

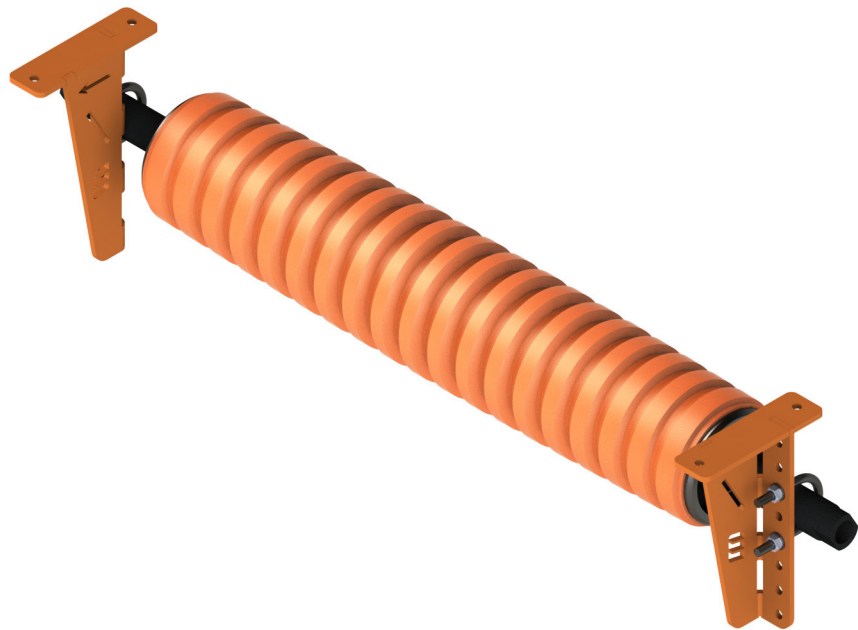

Operator's Manual
M4027

Important

MARTIN ENGINEERING HEREBY DISCLAIMS ANY LIABILITY FOR: DAMAGE DUE TO CONTAMINATION OF THE MATERIAL; USER'S FAILURE TO INSPECT, MAINTAIN AND TAKE REASONABLE CARE OF THE EQUIPMENT; INJURIES OR DAMAGE RESULTING FROM USE OR APPLICATION OF THIS PRODUCT CONTRARY TO INSTRUCTIONS AND SPECIFICATIONS CONTAINED HEREIN. MARTIN ENGINEERING'S LIABILITY SHALL BE LIMITED TO REPAIR OR REPLACEMENT OF EQUIPMENT SHOWN TO BE DEFECTIVE.

Observe all safety rules given herein along with owner and Government standards and regulations. Know and understand lockout/tagout procedures as defined by American National Standards Institute (ANSI) z244.1-1982, *American National Standard for Personnel Protection - Lockout/Tagout of Energy Sources - Minimum Safety Requirements* and Occupational Safety and Health Administration (OSHA) Federal Register, Part IV, 29 CFR Part 1910, *Control of Hazardous Energy Source (Lockout/Tagout); Final Rule*.

The following symbols may be used in this manual:



Danger: Immediate hazards that will result in severe personal injury or death.



Warning: Hazards or unsafe practices that could result in personal injury.



Caution: Hazards or unsafe practices that could result in product or property damages.



Important: Instructions that must be followed to ensure proper installation/operation of equipment.



Note: General statements to assist the reader.

Installation



⚠ DANGER

Before installing, servicing, or adjusting the conveyor equipment, turn off and lockout / tagout / blockout / testout all energy sources to the conveyor and conveyor accessories according to ANSI standards. Failure to do so could result in serious injury or death.

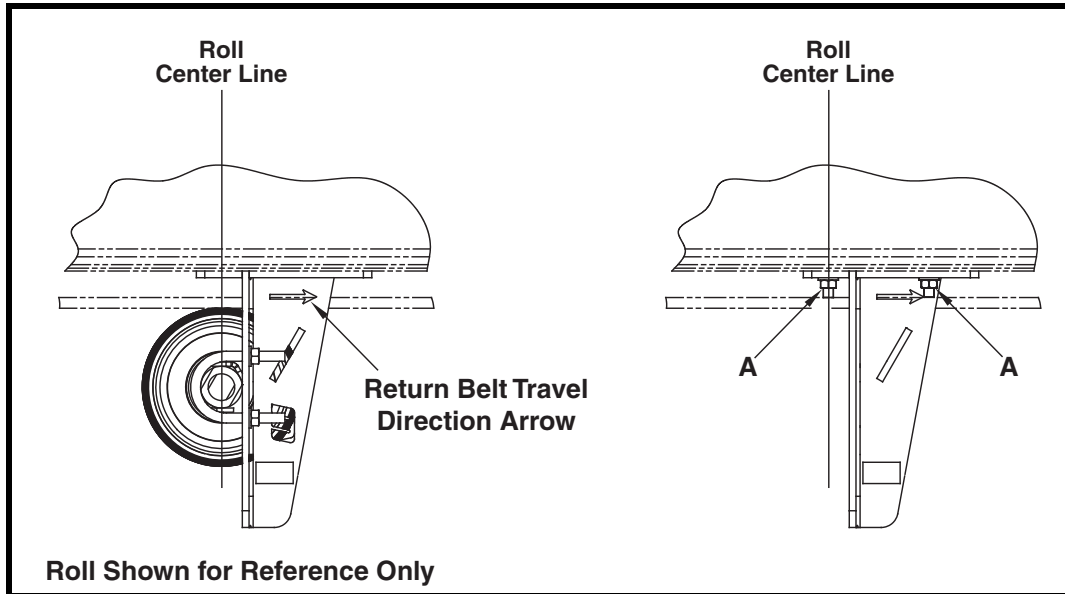

Figure 1. Martin® Roller Tracker™ Mounting Location

1. Turn off and lockout / tagout / blockout / testout energy source according to ANSI standards.
2. Remove existing return belt idler and brackets.

NOTE

Arrow on bracket indicates belt direction. Make sure bracket is installed with arrow pointing the direction the return side of the belt will be traveling.

3. Mark center line of Martin® Roller Tracker™ roll on stringer. Make sure center line is perpendicular to belt line.
4. Using the bracket as a template, align small slot on mount bracket with roll center line and mark location of mounting holes.
5. Drill or cut holes in stringer. Remove burrs and sharp edges.
6. Install bracket onto stringer using cap screws, washers, and nuts (A).
7. Repeat steps 3–6 on opposite side of conveyor.

IMPORTANT

Set height of Martin® Roller Tracker™ approximately 3/16 in. (5 mm) higher than removed return idler.

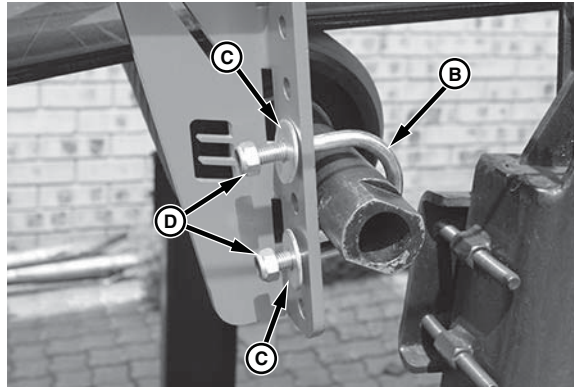

Figure 2. Installing Roll onto Brackets

8. Determine proper mounting holes on brackets. Install roll onto brackets using U-bolts (B). Fasten U-bolts with washers (C) and nuts (D), but do not fully tighten.
9. Center roll on stringer.

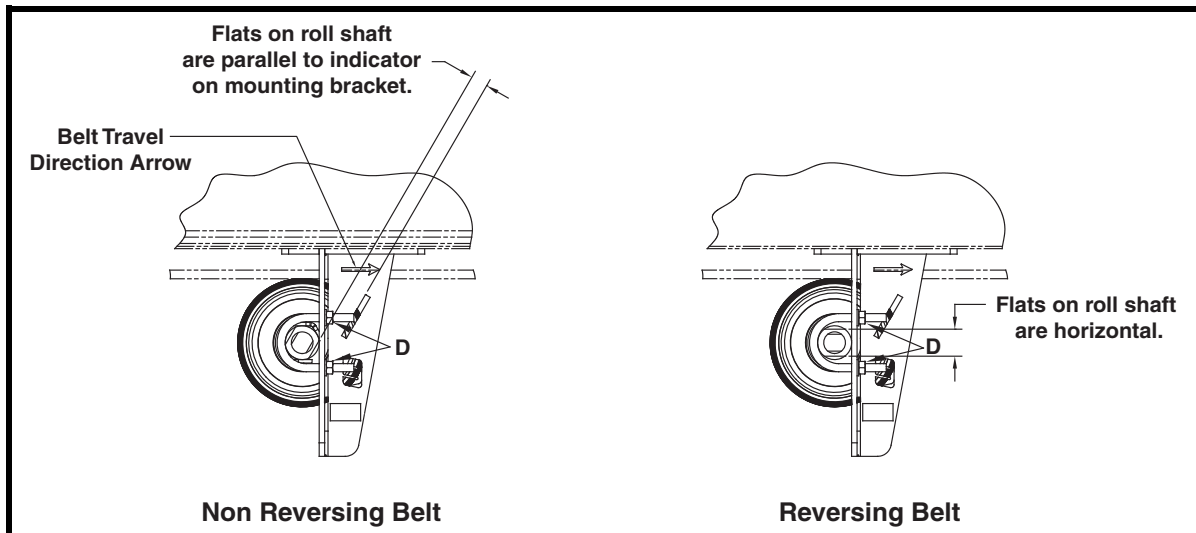

Figure 3. Roll Shaft Orientation

10. For non reversing belts, rotate center shaft of roll so machined flats on shaft are parallel with indicator on bracket. Approximate angle is 30 degrees towards the direction of the return belt.
11. For reversing belts, rotate center shaft of roll so machined flats on shaft are horizontal.
12. Tighten nuts (D) on U-bolts.
13. Make sure all fasteners are tight and remove all tools from installation area.

Part Numbers

NOMENCLATURE

MRT XX

P/N Prefix

Belt Width (inches)

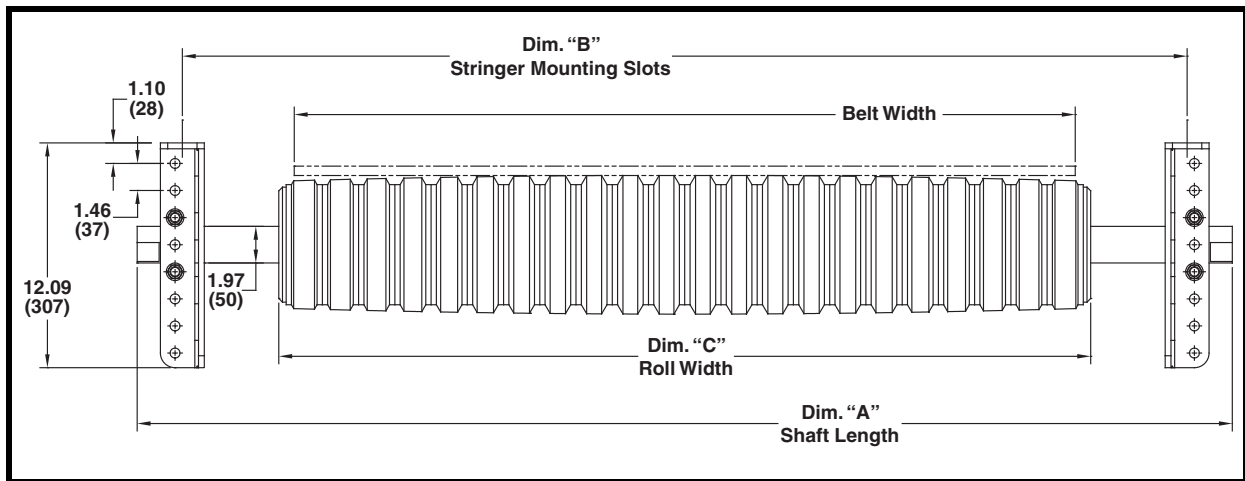
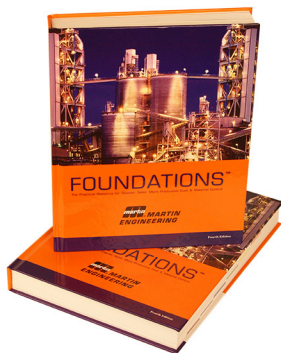

Table I. Martin[®] Roller Tracker[™] Dimensions

Assembly P/N	Belt Width in. (mm)	Dim. "A"	Dim. "B"	Dim. "C"
MRT-20	20 (500)	36.97 (939)	28.98 (736)	22.24 (565)
MRT-24	24 (600)	40.87 (1038)	32.99 (838)	26.14 (664)
MRT-30	30 (750)	46.85 (1190)	38.98 (990)	31.97 (812)
MRT-36	36 (900)	52.91 (1344)	45.04 (1144)	37.83 (961)
MRT-42	42 (1050)	58.90 (1496)	51.02 (1296)	43.66 (1109)
MRT-48	48 (1200)	64.88 (1648)	57.01 (1448)	49.53 (1258)
MRT-54	54 (1350)	70.87 (1800)	62.99 (1600)	57.32 (1456)
MRT-60	60 (1500)	76.85 (1952)	68.98 (1752)	63.15 (1604)

Any product, process, or technology described here may be the subject of intellectual property rights reserved by Martin Engineering Company. Trademarks or service marks designated with the ® symbol are registered with the U.S. Patent and Trademark Office and may be proprietary in one or more countries or regions. Other trademarks and service marks belonging to Martin Engineering Company in the United States and/or other countries or regions may be designated with the “TM” and “SM” symbols. Brands, trademarks, and names of other parties, who may or may not be affiliated with, connected to, or endorsed by Martin Engineering Company, are identified wherever possible. Additional information regarding Martin Engineering Company’s intellectual property can be obtained at www.martin-eng.com/trademarks.

Problem Solved™ ***GUARANTEED!***



For nearly 20 years, Martin Engineering's Foundations™ Books have taught industry personnel to operate and maintain clean and safe belt conveyors. The Foundations™ Book, fourth edition, focuses on improving belt conveyors by controlling fugitive material. "The Practical Resource for Total Dust and Material Control," is a 576-page hard cover volume that provides information of value to industries where the efficient handling of bulk materials is a key to productivity and profitability.

Expanding upon the book, our Foundations™ Training Program addresses the design and development of more productive belt conveyors, and is offered in three customizable seminars. Attendees gain a better understanding of conveyor safety and performance, helping to justify upgrade investments and increase profitability.



Martin Engineering USA

One Martin Place
Neponset, IL 61345-9766 USA
800 544 2947 or 309 852 2384
Fax 800 814 1553
www.martin-eng.com

**COMPANY WITH
QUALITY SYSTEM
CERTIFIED BY DNV
= ISO 9001:2008 =**