



# CleanScrape® Medium, Large & HD Cleaner



## Operating Instructions

Version: 0

M4033EUK-06/20

## Table of Contents

---

<b>1 General</b> .....	<b>3</b>
1.1 About these operating instructions .....	3
1.2 General information on cleaners.....	4
1.3 Intended usage .....	4
1.4 Use in hazardous areas according to the ATEX directive .....	5
1.5 Personnel qualification.....	6
1.6 Technical data .....	6
1.7 Requirements for the usage site .....	7
<b>2 Safety</b> .....	<b>8</b>
2.1 General safety instructions .....	8
2.2 Personal protective equipment .....	9
2.3 Safety markings on the system.....	9
2.4 Special safety instructions for usage in ATEX areas .....	10
<b>3 Preparations before installation</b> .....	<b>11</b>
3.1 Required maximum of tools and materials.....	11
3.2 Checking the operating conditions.....	12
3.3 Unpacking/transportation.....	12
3.4 Identification of the correct installation position .....	13
<b>4 Before Installation Belt Cleaner</b> .....	<b>18</b>
4.1 Installing chains .....	19
<b>5 Installing Belt Cleaner &amp; Tensioners</b> .....	<b>20</b>
5.1 Locating belt cleaner.....	21
<b>6 After Installing Belt Cleaner</b> .....	<b>29</b>
<b>7 Maintenance / Servicing / Repair</b> .....	<b>31</b>
7.1 Replacing Breakaway Link .....	33
<b>8 Troubleshooting</b> .....	<b>35</b>
<b>9 Disassembly / Recycling / Disposal</b> .....	<b>38</b>
<b>10 Part Numbers</b> .....	<b>39</b>
<b>11 Appendix</b> .....	<b>45</b>

# 1 General

---



## NOTE

Before starting work on the cleaner or the conveyor, these operating instructions must be read and understood completely

## 1.1 About these operating instructions

These operating instructions apply solely for cleaners and are intended for those persons who install cleaners, commission them, and monitor their usage. The operating instructions must be kept for the lifetime of the cleaners and must be made available in an orderly condition to all persons entrusted with work with and on the cleaners.

All illustrations are schematic representations and make no claim to completeness.

## 1.2 General information on cleaners

Cleaners are used in the discharge area of the belt conveyor to remove adhering bulk material from conveyor belts. The cleaning result is increased by using multiple cleaners.

Pre-cleaners are installed at the head pulley, below the discharge parabola of the bulk material.

Secondary cleaners are installed behind pre-cleaners when viewed in the direction of belt travel and are used for fine cleaning of the conveyor belts. The typical installation position is behind the discharge pulley, but still inside the chute enclosure.

These operating instructions describe actions and measures for the use of cleaners on closed discharge enclosures of the conveyor. If the discharge area of the conveyor is not enclosed, the operator must take precautions to ensure that the cleaners can be relocated, installed, maintained and repaired in the same way.

Furthermore, the operator must ensure that all necessary protective measures for safe operation of the system with cleaners have been taken.

Cleaners must be easy to check, clean and maintain. Appropriate means of access must be provided for this purpose.

## 1.3 Intended usage

Cleaners are used for mechanical removal of bulk material sticking on conveyor belts with smooth surfaces. They may only be used:

- in the industrial area above ground
- on the carrying side of the conveyor belts
- according to the technical data in the documentation
- in the installation position as described in the documentation

The usage of the cleaners is only considered to be as intended if the following conditions are also fulfilled:

- Before starting initial work, the personnel must have been instructed on the work on the system and on all relevant issues of occupational health and safety
- Any personal protective equipment required must be worn
- The provisions of the operating instructions must be observed in full.

Operation of the cleaners under deviating conditions and unauthorised modification of the cleaners is considered as improper usage.

#### 1.4 Use in hazardous areas according to the ATEX directive

The standard version of the cleaner is NOT suitable for use in hazardous areas.

Martin Engineering offers special product variants that are suitable for use in ATEX zones 22 and 21 under certain circumstances. These product variants contain mandatory additional components or have special product characteristics.

Special instructions for the use of cleaners in ATEX zones must be observed.

Requirements for the use of these special product variants:

- Minimum ignition energy of the bulk material: >10 mJ
- Belt connections are vulcanised
- There are no substances in the bulk material which could generate impact sparks on the cleaners.
- Coatings (corrosion protection) have standard layer thicknesses (max.80µm)
- Earthing cables are properly installed (Bleeder resistance < 10<sup>6</sup>Ω)

## 1.5 Personnel qualification

Only authorised and qualified personnel may be entrusted with work with and on the conveyors and cleaners. Persons are considered qualified if they have the qualification of a skilled worker and meet all the following requirements:

- completed professional training or at least 5 years of professional experience in the field,
- technical experience,
- knowledge of the relevant occupational health and safety regulations.

The persons must

- be able to assess the tasks and risks assigned to them,
- be able to recognise potential dangers in advance,
- be physically and cognitively able to operate the conveyors and cleaners safely,
- have been trained and instructed appropriately,
- have read and understood these operating instructions.

Work on earth connections, cabling, switching, control, regulation, automation and all electrical components may be carried out only by trained electricians.

## 1.6 Technical data

	Operating parameter Size M
Belt widths:	500 ... 1.800 mm
Pulley diameter:	550 ... 900 mm
Belt speed:	4 m/s for conveyor belts with mechanical splices
	8 m/s for conveyor belts with vulcanised splices
Temperature range:	-25 ... +80°C
Reversing operation:	Can remain in use, but no cleaning function

	<b>Operating parameter Size L</b>
Belt widths:	800 ... 2.400 mm
Pulley diameter:	900 ... 1.250 mm
Belt speed:	4 m/s for conveyor belts with mechanical splices
	8 m/s for conveyor belts with vulcanised splices
Temperature range:	-25 ... +80°C
Reversing operation:	Can remain in use, but no cleaning function

	<b>Operating parameter Size HD</b>
Belt widths:	1.000 ... 3.000 mm
Pulley diameter:	800 ... 2.000 mm
Belt speed:	6 m/s for conveyor belts with mechanical splices
	8 m/s for conveyor belts with vulcanised splices
Temperature range:	-25 ... +80°C
Reversing operation:	Can remain in use, but no cleaning function

## 1.7 Requirements for the usage site

---

*For information on the required spatial requirements of the cleaner and the tensioner, see the following chapters.*

---

## 2 Safety

---

### 2.1 General safety instructions



#### DANGER

##### Entanglement in conveyor belt

Clothing or body parts can become entangled in the conveyor and cause serious or fatal injuries.

Tensions may be released in the conveyor belt and cause movement of the bulk material without prior detection.

- *Do not carry out any work on the conveyor belt while it is in operation or reach into the moving conveyor belt!*
- *Secure the conveyor against unintentional restart! Use lockout / tagout / blockout / testout procedures!*
- *Install suitable guards to prevent access to the infeed section!*



#### WARNING

##### Danger of injury due to unapproved component parts

Unapproved parts can directly or indirectly cause personal injury or damage to property.

- *Only use accessories and spare parts that are distributed by the manufacturer or are explicitly approved (in writing)!*



#### WARNING

##### Working in confined spaces

Areas in which cleaners are installed are often difficult to access and include confined spaces. It is often necessary to work in difficult positions.

- *Determine whether occupational safety measures are necessary that go beyond the usual measures!*



#### WARNING

##### Risk of falling down

Cleaners are often mounted and operated in heights. There may be a risk of falling down.





- *Therefore, use a fall protection device when installing in higher working areas!*



## 2.2 Personal protective equipment

Persons carrying out work on cleaners must wear suitable personal protective equipment.

Minimum requirements:

Symbol	Meaning
	Wear head and eye protection.
	Wear at least ankle-high foot protection.
	Use gloves.
	Use fall protection.

## 2.3 Safety markings on the system

The safety markings on the cleaners must be kept in good condition and clearly visible at all times.

If parts of the system are replaced, ensure that the spare parts are or will be provided with appropriate warning signs.

## 2.4 Special safety instructions for usage in ATEX areas



### DANGER

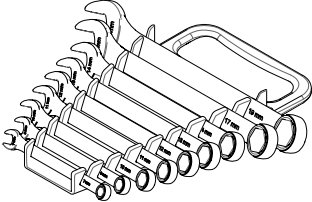
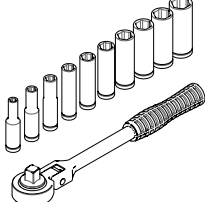
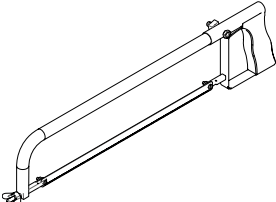
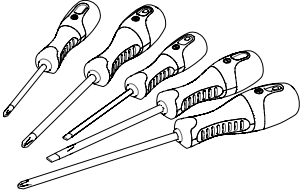
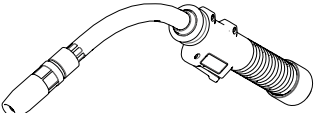
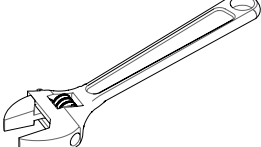
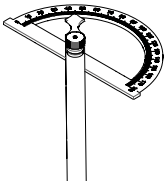
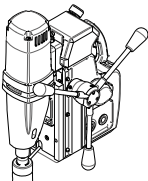
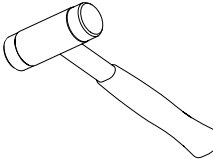
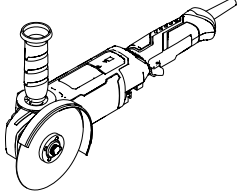
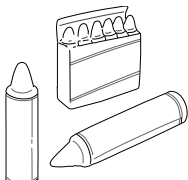
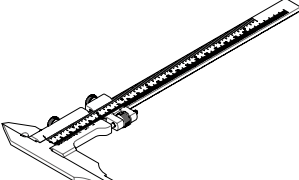
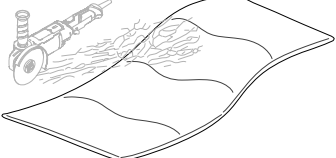
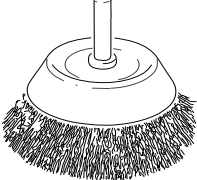
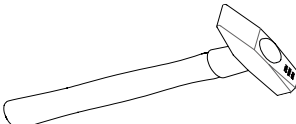
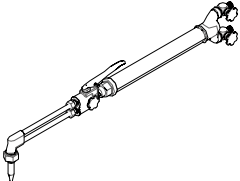
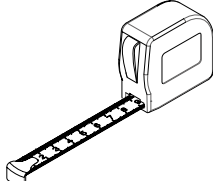
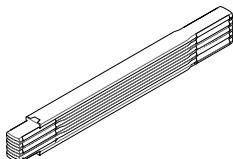
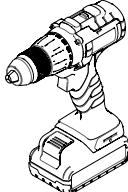
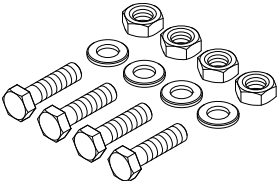

#### Usage in ATEX zones 22 and 21

Combustible dust can cause explosions and thus cause serious or fatal injuries.

- *Ensure that all explosion-related parameters and operating modes are observed.*
- *Observe all instructions for usage in hazardous areas.*
- *Ensure that the bulk material meets the specified requirements before the conveyor is switched on.*
- *Ensure that the cleaners are suitable for all explosion-related parameters and operating modes of the application.*
- *Ensure that the conveyor belts do not have any metallic connectors. All belt connections must be vulcanised.*
- *Ensure that the bulk material is free of foreign substances that could create an ignition source for the dust/air mixture.*
- *Ensure that any necessary metal-separating devices are operating effectively.*
- *Install cleaners in such a way that no metal part can contact moving components even when the blade is completely worn.*
- *Use only tools and aids that are approved for use in the respective ATEX zone.*
- *Ensure that the cleaners are tensioned against the conveyor belt with the maximum forces / tension values specified.*
- *Ensure that the earth connections of the cleaners are installed correctly.*
- *Use only cleaners as special product variants that are suitable for use in potentially explosive areas.*
- *Measure the gas and dust content of the environment before using open flames.*
- *Prevent electrostatic charges, for example by cleaning plastic enclosures with a dry cloth.*
- *Work on earth connections, cabling, switching, control, regulation, automation and all electrical components may be carried out only by trained electricians.*

### 3 Preparations before installation

#### 3.1 Required maximum of tools and materials

### 3.2 Checking the operating conditions

Before installation, check whether the cleaner is suitable for the application. For this purpose, it must be ensured that:

- the available space allows unobstructed installation, maintenance and repair of the cleaner,
- the cleaner meets the requirements for the respective operation (ambient conditions, operating mode of the conveyor, properties of the bulk material, fire protection, explosion protection, etc.)
- a plugged conveyor chute may cause additional pressure against the cleaner and may cause damage belt. Ensure conveyor chute remains unplugged. Use a plugged chute sensor where appropriate.
- special product variants are used if the cleaners are operated in ATEX zones 22 and 21 and all explosion-related parameters and operating modes are observed.
- Ensure the conveyor belt is free of damages. Especially belt edge damages and protruding parts of the conveyor belt can get caught in the cleaner and cause further damage.

### 3.3 Unpacking/transportation



#### WARNING

##### Heavy weight

The cleaners may have weights that require handling by lifting devices. Handling heavy cleaners by hand can cause serious skeletal injuries.

- *Use suitable aids if the load is > 25 kg per person!*
- *Identify the centre of gravity! Ensure that the cleaner cannot tilt during the lifting process!*

- Inspect shipping container for damage. Report damage to delivery service immediately and fill out delivery service's claim form. Keep any damaged goods subject to examination.
- Remove belt cleaner assembly from shipping container.
- If anything is missing contact Martin Engineering or a representative.

### 3.4 Identification of the correct installation position

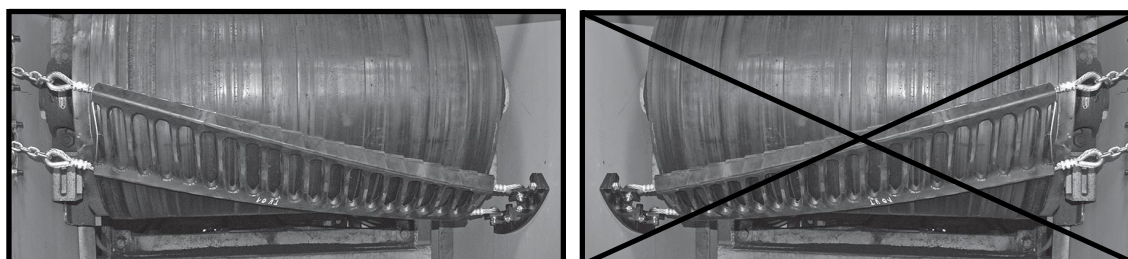


#### NOTE

The correct installation position of the cleaner and the tensioner can be found in chapter 11 Appendix.

- *Ensure that the specified installation positions are fully observed.*
- *Ensure that maintenance of the cleaner can be carried out without problems.*
- *Provide the required possibilities for inspection and maintenance.*

#### General Instructions



**Correct Mounting Position    Incorrect Mounting Position**

**Figure 1: Belt Cleaner Mounting Orientation**

Inspect belt cleaner mounting area for possible obstructions that could interfere with proper mounting. Refer to following guidelines:

- Ensure cleaner does not lie in path of material unloading from conveyor belt.
- The top side of cleaner should be no less than the 2 o'clock position. Material could strike the back of the cleaner causing wear which will lead to premature failure.
- The ideal installation angle is 17°–18°. Installation angles of 15°–21° are acceptable. Higher angles are normally utilized in cleaning material that tends to adhere to the belt, these higher angles lead to increased wear on the blade.

- Belt width must not exceed a ratio of 3:1 to the head pulley diameter. For example, the maximum belt width for a conveyor with a 600 mm (24 in.) head pulley is 1.800 mm (72 in.).
- Chute walls must be strong enough to not flex as tension is applied to cleaner. If chute wall flexes inadequate tension may be applied to cleaner resulting in poor cleaning performance. Additional chute wall structure support may be added to prevent chute wall from flexing.
- The distance between the cleaner and the chute wall should be minimized. Martin Engineering recommends keeping the distance to 125mm (5 in.) maximum per side (see Figure 4). Excess chain or cable could result in vibration that could damage the belt or the cleaner. If necessary, build a sub-wall to support the tensioners in the proper position. Consult Martin Engineering for installation assistance if parameters fall outside of this range.
- For typical installations, start with the bottom rope in the Belt-Exit-Point which is typically in the 6 o'clock position. The exact positioning of the top rope is a result of the installation angle, typically in the 3 o'clock position.
- For belts with low product flow, lower the top rope until cleaner is out of material path. Cleaner angle must be 15° or greater.

Lack of service can contribute to poor belt cleaning performance. Follow local guidelines for access:

- Clearance for service outside the chute must be at least equal to the belt width.
- Cleaners must have service platforms. Cleaners should be mounted at least 600 mm (24 in.) above the work platform.
- If the belt width is 1.400 mm (54 in.) or larger consider access doors on both sides of the chute.

### Typical Belt Cleaner Mounting Positions

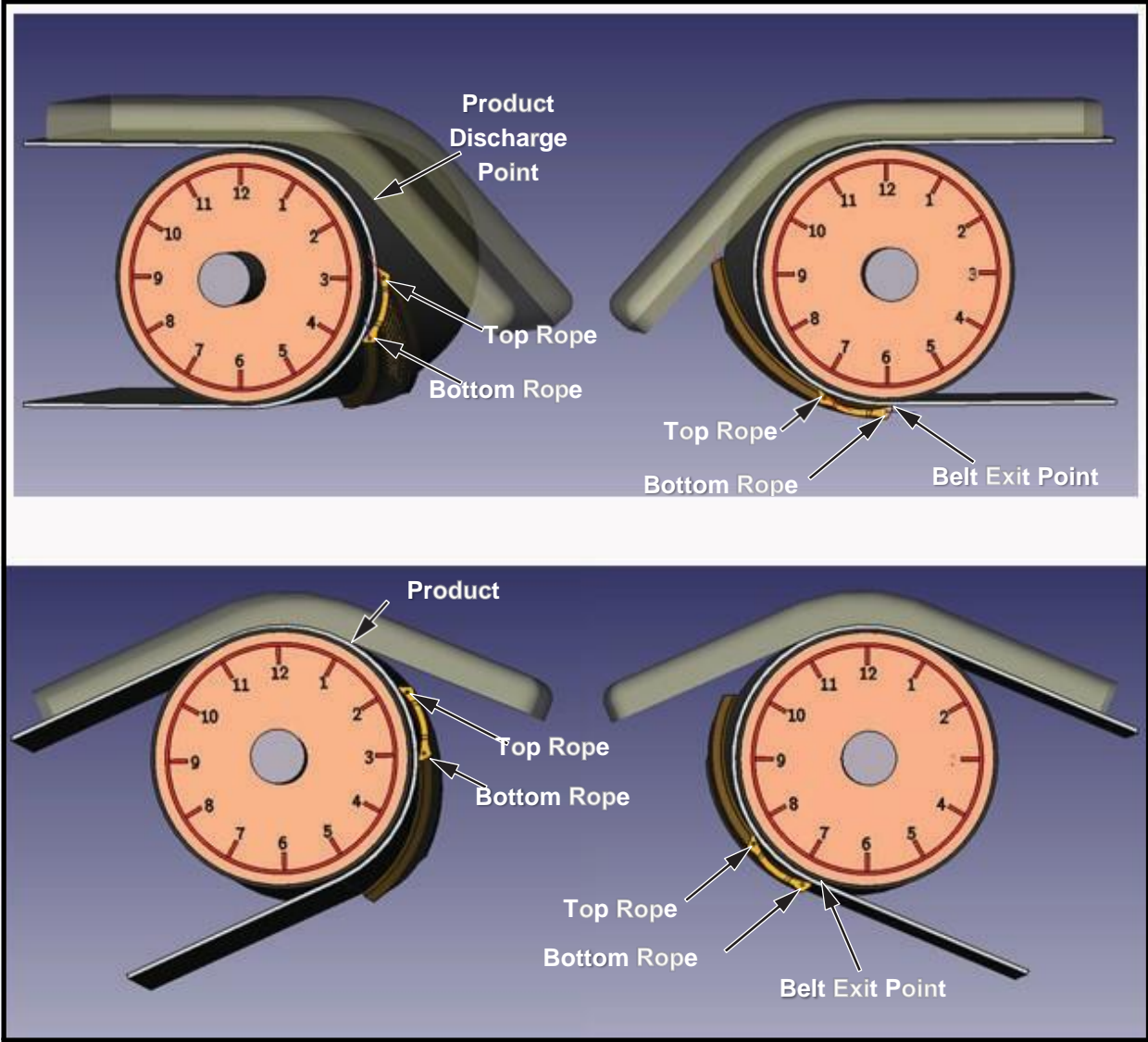


Figure 2: Typical Belt Cleaner Mounting Positions



### Low Product Flow Belt Cleaner Mounting Positions

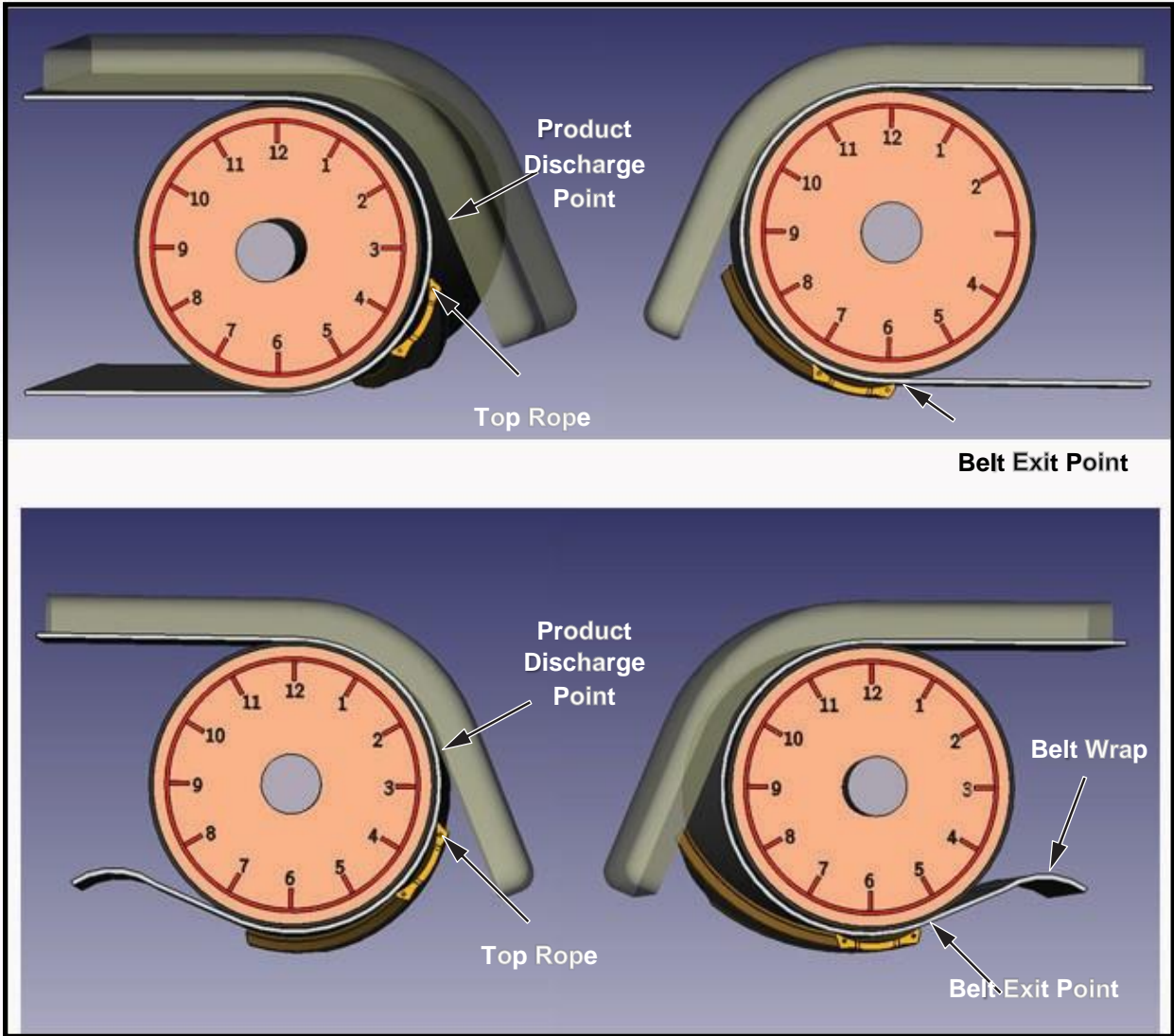


Figure 3: Low Product Flow Belt Cleaner Mounting Positions



## Installations with Wide Chute Walls

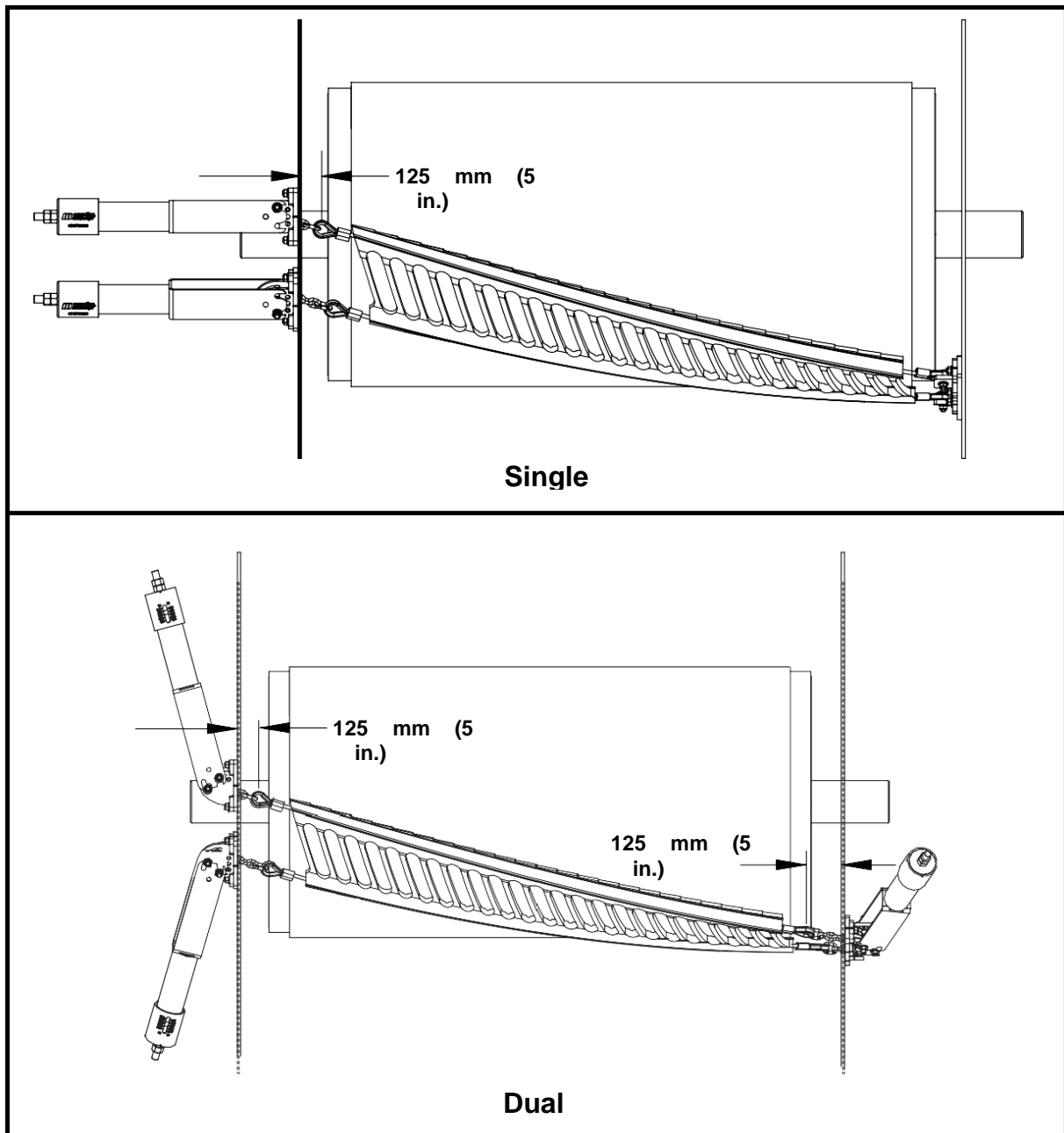


Figure 4: Installations with Wide Chute Walls



### NOTE

The maximum distance between chute wall and center of thimble is 125 mm (5 in.). Excess free chain or cable causes too much vibration resulting in damage to cleaner and components. If necessary, build a sub wall to support the tensioners and/or install wide chute wall kit, see Figure 15

## 4 Before Installation Belt Cleaner

---



### DANGER

---

---

#### Entanglement in conveyor belt

Clothing or body parts can become entangled in the conveyor and cause serious or fatal injuries.

Tensions may be released in the conveyor belt and cause movement of the bulk material without prior detection.

- *Do not carry out any work on the conveyor belt while it is in operation or reach into the moving conveyor belt!*
- *Secure the conveyor against unintentional restart! Use lockout / tagout / blockout / testout procedures!*
- *Install suitable guards to prevent access to the infeed section!*



### DANGER

---

---

#### Automatic start-up of the conveyor

Serious or fatal injuries due to unintentional start-up of the conveyor.

- *Switch off the conveyor before starting work and secure it against being switched on again.*
- *Follow safe procedures to prevent unintentional restart.*



### WARNING

---

---

#### Heavy weight

The cleaners may have weights that require handling by lifting devices. Handling heavy cleaners by hand can cause serious skeletal injuries.

- *Use suitable aids if the load is > 25 kg per person!*
- *Identify the centre of gravity! Ensure that the cleaner cannot tilt during the lifting process!*

## 4.1 Installing chains



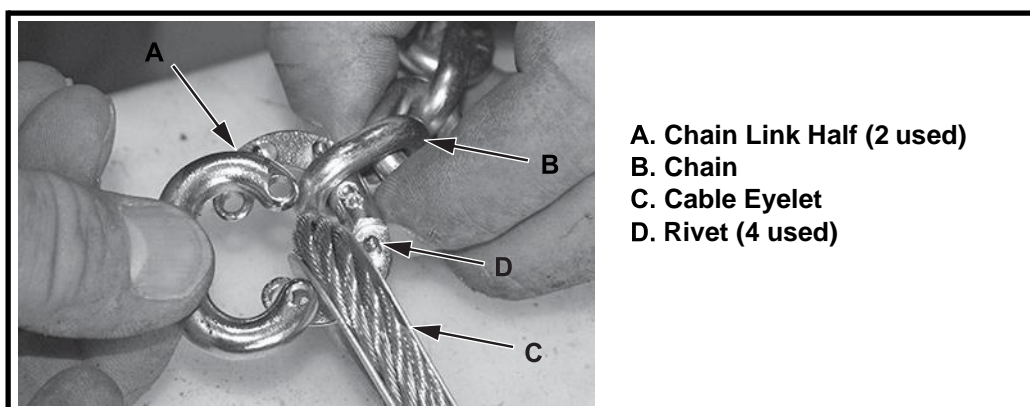
### NOTE

The chute wall that the tensioners will be located on is referred to as the “operator side.” The other side of the chute is referred to as the “far side.”



### NOTE

Chains must be installed on the same side of chute tensioners will be located on. Tensioners and chains can be installed on either side of cleaner with tensioner on top as preferred location, but cleaner orientation must be as shown in Figure 1.



**Figure 5: Installing Chains and Breakaway Links**

1. Determine operator side of chute and cleaner.
2. Install supplied chains on operator side of cleaner as follows:
  - a) Install one half of chain link (A) onto chain (B) and cable eyelet (C).
  - b) Install second half of chain link onto first half.
  - c) Place link on solid surface andpeen rivets (D) to lock chain link halves together.
  - d) Repeat steps a–c for second chain

## 5 Installing Belt Cleaner & Tensioners

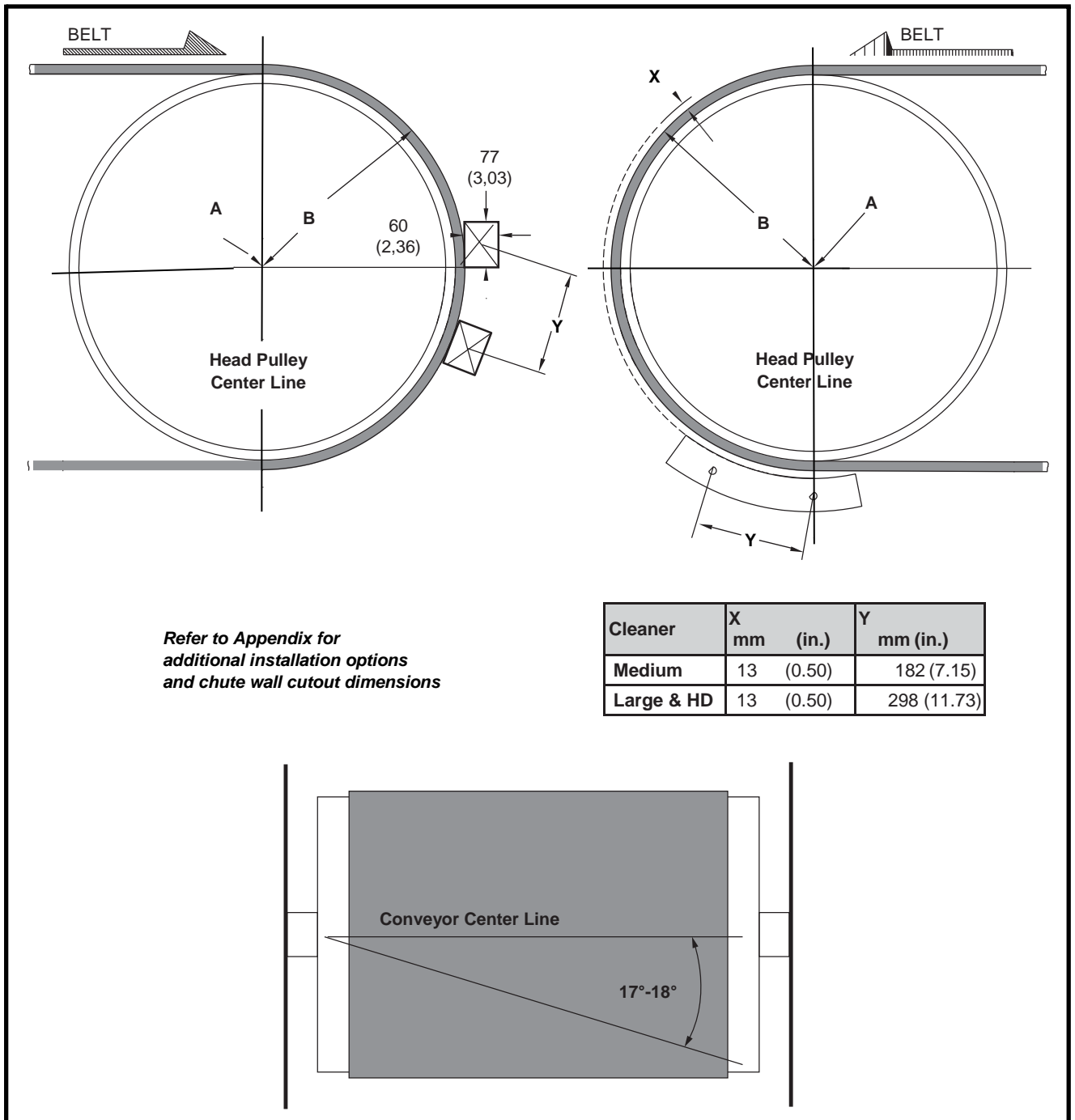


Figure 6: Belt Cleaner Location & Chute Wall Cutouts

## 5.1 Locating belt cleaner

1. On both sides of chute, find pulley center point (A).
2. Measure radius of head pulley including lagging and belt thickness (B). To this dimension, add dimension X from Figure 6.
3. On the far side of chute, start from center point (A), measure the total distance calculated in step 2 ( $B + X$ ), and draw an arc on chute wall.
4. On the operator side of chute, start from center point (A), draw an arc on chute wall with a radius of (B).

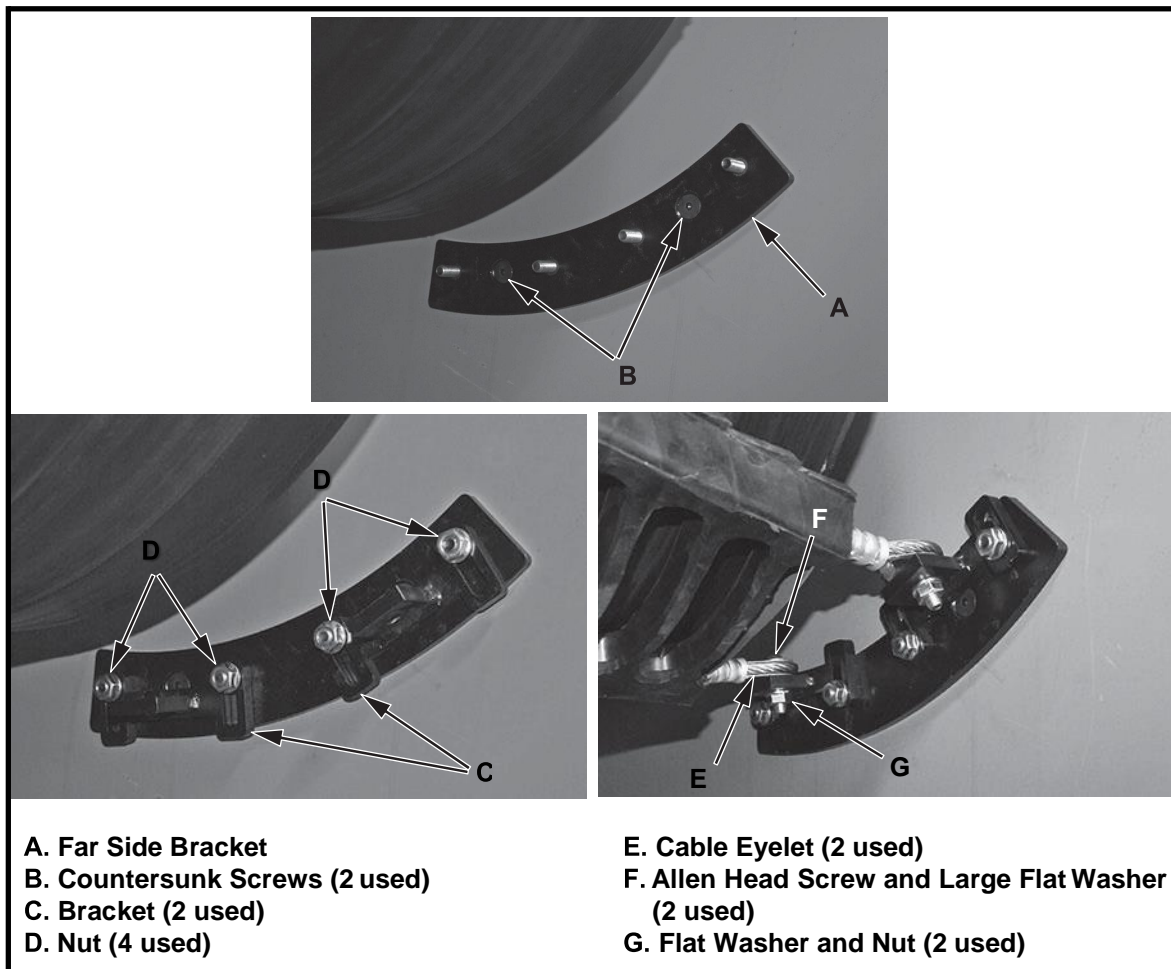


Figure 7: Installing Fixed Point Bracket

5. On the far side of chute:
- a) Draw a centerline of the head pulley perpendicular to the conveyor belt line (see Figure 6). Rotate the bottom side mount back as far as possible in order to achieve at least 17° of belt wrap while not exceeding the belt exit (see Figures 2 & 3).
  - b) If bolting fixed point bracket to chute wall, do the following:
    - (1) Position fixed point bracket on far side chute wall as shown in Figure 6 (centerline install is used as an example).
    - (2) Mark bracket hole locations.
    - (3) Drill or cut two 13 mm (1/2-in.) holes for screws in far side chute wall.
    - (4) Mount fixed point bracket to inside of far side chute wall using countersunk screws (B) and nuts.
  - c) If welding fixed point bracket to chute wall, do the following:
    - (1) Position fixed point bracket on far side chute wall as shown in Figure 6 (centerline install is used as an example).
    - (2) Weld bracket to chute wall. Weld completely around bracket. Do not skip weld

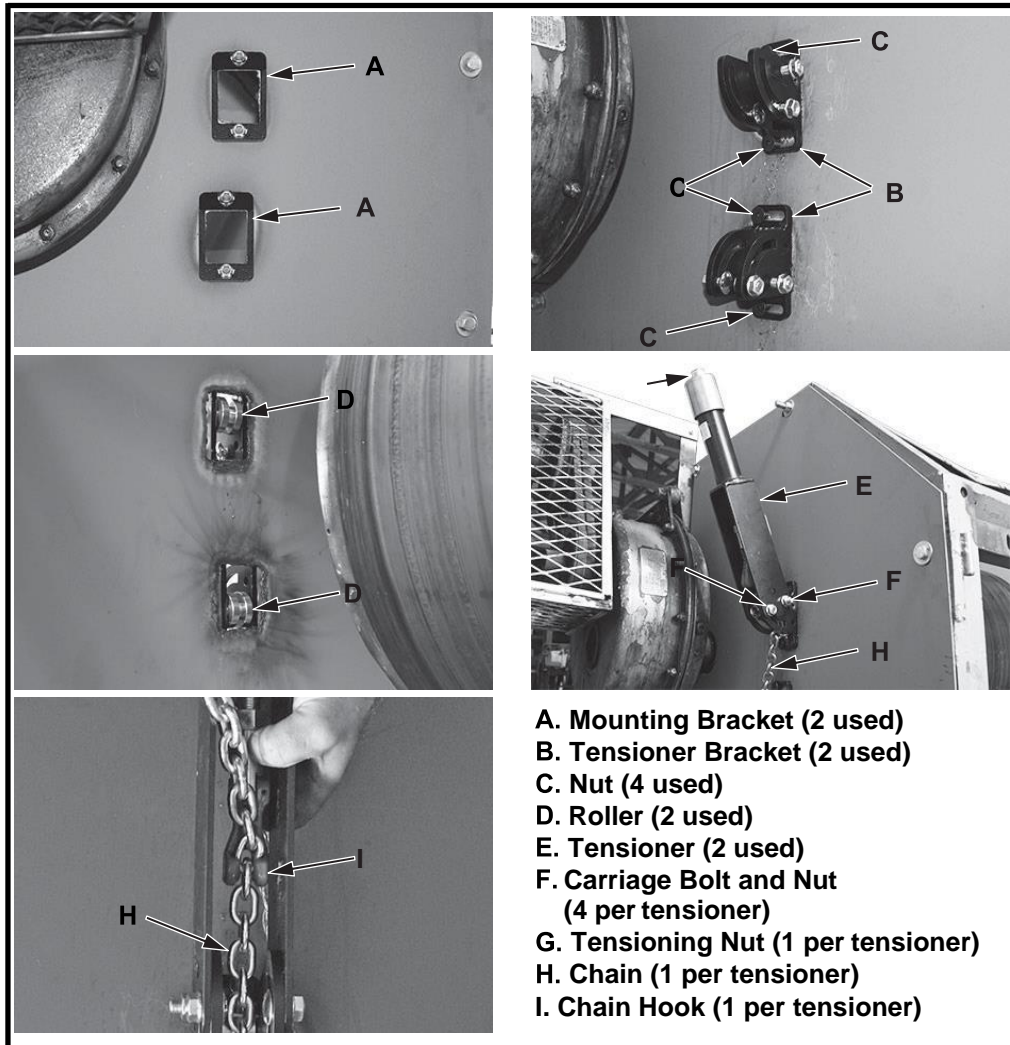


#### NOTE

If wide chute wall adapter is required, see Figure 14. Wide chute wall adapter kit, P/N C1CP30000X. Bracket installation instructions are included in kit.

- d) Install brackets (C) using nuts (D). Hand tighten nuts (see Figure 7).
- e) Attach cleaner to far side bracket by inserting hex head screw and large flat washer (B) through cable hook (A) and fastening with flat washer and nut (C). Hand tighten nuts.

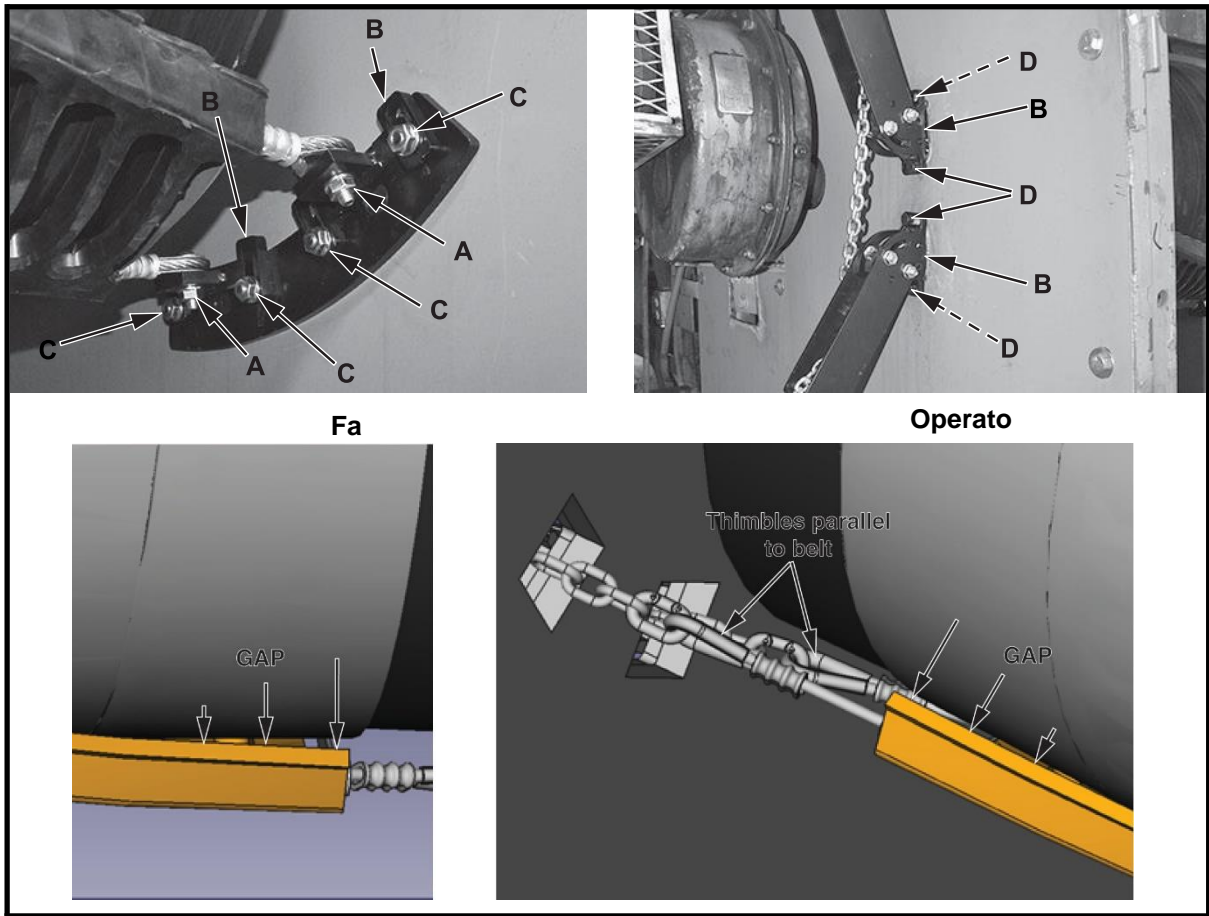
## Installing Tensioners



*Figure 8: Installing Tensioners*

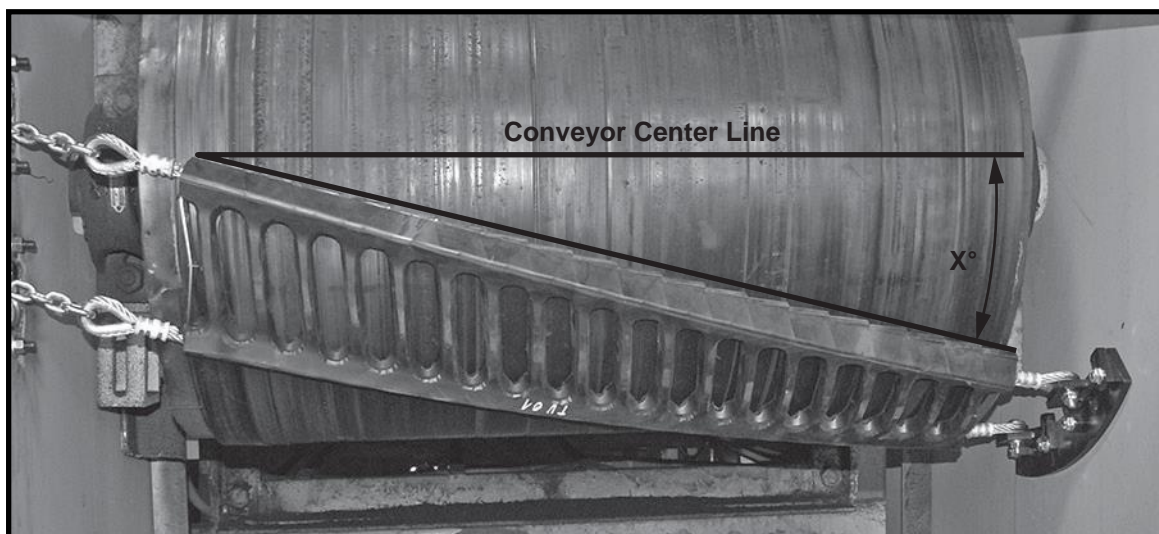
6. On the operator side of chute:
  - a) Draw conveyor centerline parallel to the conveyor belt line.
  - b) Draw a line at 17° from bottom hole of bottom bracket to location of bottom hole on top bracket, or utilize a string or elastic band to locate proper angle. Attach string to bottom hole on bottom bracket and hold it to head pulley centerline at 6:00 o'clock position on opposite chute, check angle, adjust angle to stay below product discharge point (see Figures 2 & 3). Mark location for bottom hole of top side tensioner.
  - c) Position weld plate as shown in Figure 6. The edge of the cutout should be tangent to the belt edge. Mark chute wall cutout as shown in Figure 6.
  - d) Mark upper bracket chute wall cutout as shown in Figure 6. Dimension Y is equal to the distance between mount holes on far side bracket.
  - e) Cut holes in chute wall. Remove burrs and sharp edges.
  - f) Center mounting brackets (A) on cutouts and weld to chute wall (see Figure 8).
  - g) Mount tensioner brackets (B) onto mounting bracket using nuts (C). Hand tighten nuts. Position top bracket with roller (D) in the upper position and bottom bracket with roller (D) in the lower position.
7. Mount tensioner (E) onto bracket using carriage bolts and nuts (F).
8. Position tensioner in desired location free from obstructions and tighten nuts (F).
9. Loosen nut (G) to the end of the threaded rod.
10. Hold cleaner against head pulley. Make sure the thimble is parallel to the surface of the belt.
11. Route chain (H) through chute wall and tensioner bracket.
12. Pull chain into hook (I).
13. Repeat steps 6–11 for remaining tensioner.
14. Ensure thimbles are parallel to belt (Figure 9).
15. Tighten tensioner nut (G) until center of cleaner is held firmly against head pulley.
16. Make sure each chain contacts roller in tensioner bracket (B) properly.





**Figure 9: Positioning Cleaner**

17. Tighten nuts (A).
18. Adjust brackets (B) on the operator side and far side, so outer two elements on each side are away from the belt. Increase the number of elements off the belt as necessary in order to ensure the mechanical splices will pass.
19. Tighten nuts (C) and countersunk screws and nuts (D).



**Figure 10: Measure Cleaner Angle**

20. Measure angle of cleaner.
21. Determine tension required according to tensioning chart.
22. Tighten tensioners.
  - a) If threaded spindle is not long enough to achieve desired tension (see Figure 8):
    - (1) Insert screw driver through hole in the lower part of the tensioner and chain (H), to secure the chain.
    - (2) Loosen tensioning nut (G) to release tension.
    - (3) Reinstall chain in hook (I) as close to the screw driver as possible.
    - (4) Tighten tensioning nut until required tension is achieved.
23. Install and tighten jam nut against tensioning nut on each tensioner.
24. Make sure outer elements on cleaner are positioned as follows:
  - a) For vulcanized splice, outer 2 elements on each side should be away from belt on both the upper and lower ropes. Typically this results in approximately 1-2 mm (1/16-in.) distance of elements to the belt surface.
  - b) For mechanical splices, outer 3–4 elements on each side should be away from belt on both the upper and lower ropes. Typically this results in approximately 3–6 mm (1/8–1/4-in.) distance of elements to the belt surface. Increase gap as necessary in order to ensure the mechanical splices will pass.
  - c) For reversing belts, ensure gap on both top and bottom sides are sufficient for splice passage while belt is traveling in either direction.
25. Make sure there is sufficient clearance between chute wall cutouts and chains. When running under heavy load, the blade will be pushed down. Any rubbing of the chain and/or safety link when the belt is running can cause breakages.
26. If using Martin® Inspection Door, cut access door opening and mounting holes according to Martin® Inspection Door Operator's Manual.

CSP Size	Belt Width		Upper Rope Force Required	Lower Rope Force Required*
	mm	(in.)		
Medium	600	24	1.50 kN	1.20 kN
	601–800	30	1.80 kN	1.50 kN
	801–900	36	1.90 kN	1.60 kN
	901–1000	42	2.00 kN	1.70 kN
	1001–1200	48	2.20 kN	1.90 kN
	1201-1400	54	2.80 kN	2.40 kN
	1401–1600	60	3.00 kN	2.50 kN
	1601–1700	66	3.25 kN	2.75 kN
	1701–1800	72	3.50 kN	3.00 kN
Large	800	30	1.80 kN	1.50 kN
	801–900	36	1.90 kN	1.60 kN
	901–1000	42	2.00 kN	1.70 kN
	1001–1200	48	2.20 kN	1.90 kN
	1201-1400	54	2.70 kN	2.30 kN
	1401–1600	60	2.90 kN	2.50 kN
	1601–1700	66	3.10 kN	2.65 kN
	1701–1800	72	3.30 kN	2.80 kN
	1801–2000	78	3.50 kN	3.00 kN
	2001–2150	84	3.75 kN	3.25 kN
	2151–2400	96	4.00 kN	3.50 kN
HD	1000	42	2.00 kN	1.70 kN
	1001–1200	48	2.20 kN	1.90 kN
	1201-1400	54	2.70 kN	2.30 kN
	1401–1600	60	2.90 kN	2.50 kN
	1601–1700	66	3.10 kN	2.65 kN
	1701–1800	72	3.30 kN	2.80 kN
	1801–2000	78	3.50 kN	3.00 kN
	2001–2150	84	3.75 kN	3.25 kN
	2151–2400	96	4.00 kN	3.50 kN
	2401–2600	102	4.50 kN	4.00 kN
	2601–2750	108	4.75 kN	4.35 kN
2751–3000	120	5.00 kN	4.70 kN	

\*Lower rope should have 10% to 15% less force than upper rope.

Installation Checklist – Please make sure
✓ Pre-Cleaner blade is proper distance from belt surface on both sides of head pulley.
✓ Pre-Cleaner blade tip does not lie in path of material flow.
✓ Blade is centered on belt.

## Attaching labels

### Warning Labels

The following label must be attached to the conveyor system in the immediate vicinity of the cleaner:



### Other labels

The following labels are attached to the product:



## 6 After Installing Belt Cleaner

---



### DANGER

#### Entanglement in conveyor belt

Clothing or body parts can become entangled in the conveyor and cause serious or fatal injuries.

Tensions may be released in the conveyor belt and cause movement of the bulk material without prior detection.

- *Do not carry out any work on the conveyor belt while it is in operation or reach into the moving conveyor belt!*
- *Secure the conveyor against unintentional restart! Use lockout / tagout / blockout / testout procedures!*
- *Install suitable guards to prevent access to the infeed section!*



### DANGER

#### Automatic start-up of the conveyor

Serious or fatal injuries due to unintentional start-up of the conveyor.

- *Switch off the conveyor before starting work and secure it against being switched on again.*
- *Follow safe procedures to prevent unintentional restart.*



### WARNING

#### Heavy weight

The cleaners may have weights that require handling by lifting devices. Handling heavy cleaners by hand can cause serious skeletal injuries.

- *Use suitable aids if the load is > 25 kg per person!*
- *Identify the centre of gravity! Ensure that the cleaner cannot tilt during the lifting process!*

1. Thoroughly wipe chute wall clean above tensioner.
2. Place Conveyor Products Warning Label (see above) on outside chute wall visible to belt cleaner operator.
3. Additional safety labels are available from CEMA. For more information regarding CEMA safety labels visit [www.cemanet.org](http://www.cemanet.org).
4. Start conveyor belt. Observe belt cleaner operation for several revolutions of the belt. Properly shutdown belt and make appropriate adjustments. Return belt to service.
5. Run conveyor belt for one hour or at least 5 turns of the conveyor belt. Adjust belt cleaner as necessary.
  - a) Make sure all fasteners are tight. Tighten if necessary.
  - b) Inspect belt cleaner for the following:
    - (1) Wear. (A small amount of “break-in” wear may be found. This will stop once blades wear to conveyor belt contour.)
    - (2) Material buildup. (No material between blades and return side of conveyor belt should be found.)
    - (3) Ensure the tensioning of the cleaner is in line with the instructions, re-tension if required.
  - c) If wear, material buildup, or some other problem exists, see “Troubleshooting.”
  - d) Monitor cleaner and after 7–10 days re-tension cleaner to overcome any thimble bedding in.

## 7 Maintenance / Servicing / Repair

---



### DANGER

#### Entanglement in conveyor belt

Clothing or body parts can become entangled in the conveyor and cause serious or fatal injuries.

Tensions may be released in the conveyor belt and cause movement of the bulk material without prior detection.

- *Do not carry out any work on the conveyor belt while it is in operation or reach into the moving conveyor belt!*
- *Secure the conveyor against unintentional restart! Use lockout / tagout / blockout / testout procedures!*
- *Install suitable guards to prevent access to the infeed section!*



### DANGER

#### Automatic start-up of the conveyor

Serious or fatal injuries due to unintentional start-up of the conveyor.

- *Switch off the conveyor before starting work and secure it against being switched on again.*
- *Follow safe procedures to prevent unintentional restart.*



### WARNING

#### Heavy weight

The cleaners may have weights that require handling by lifting devices. Handling heavy cleaners by hand can cause serious skeletal injuries.

- *Use suitable aids if the load is > 25 kg per person!*
- *Identify the centre of gravity! Ensure that the cleaner cannot tilt during the lifting process!*

Interval	Component part	Activity
Daily	Cleaner	<ul style="list-style-type: none"> <li>• Visual inspection to ensure no damages or build-ups occurred.</li> </ul>
Monthly	Cleaner	<ul style="list-style-type: none"> <li>• Visual inspection for dirt and wear</li> <li>• Remove dirt if necessary</li> <li>• Replace worn components</li> <li>• Check tension, re-tension if necessary.</li> <li>• Check the screw connections for tight fit.</li> <li>• Tighten any loose connections.</li> </ul>
	Labels	

1. Remove any material from belt cleaner.
2. Make sure all fasteners are tight. Tighten if necessary.
3. Check tension on cleaner. Re-tension if necessary.
4. Wipe all labels clean. If labels are not readable, contact Martin Engineering or a representative for replacements.
5. Check blades for excessive wear. Replace blade if remaining carbide metal thickness is 2 mm (1/12 in.) or less.
6. Monitor cleaner and after 7-10 days re-tension cleaner to overcome any thimble bedding-in.
7. Remove equipment from service if there is any indication it is not functioning properly. Call Martin Engineering or a representative for assistance. Do NOT return equipment to operation until the cause of the problem has been identified and corrected.
8. Remove all tools from maintenance area.
9. Start conveyor belt. Observe belt cleaner operation for several revolutions of the belt. Service or adjust belt cleaner as necessary to ensure proper belt cleaner operation.



## 7.1 Replacing Breakaway Link



### DANGER

#### Entanglement in conveyor belt

Clothing or body parts can become entangled in the conveyor and cause serious or fatal injuries.

Tensions may be released in the conveyor belt and cause movement of the bulk material without prior detection.

- *Do not carry out any work on the conveyor belt while it is in operation or reach into the moving conveyor belt!*
- *Secure the conveyor against unintentional restart! Use lockout / tagout / blockout / testout procedures!*
- *Install suitable guards to prevent access to the infeed section!*



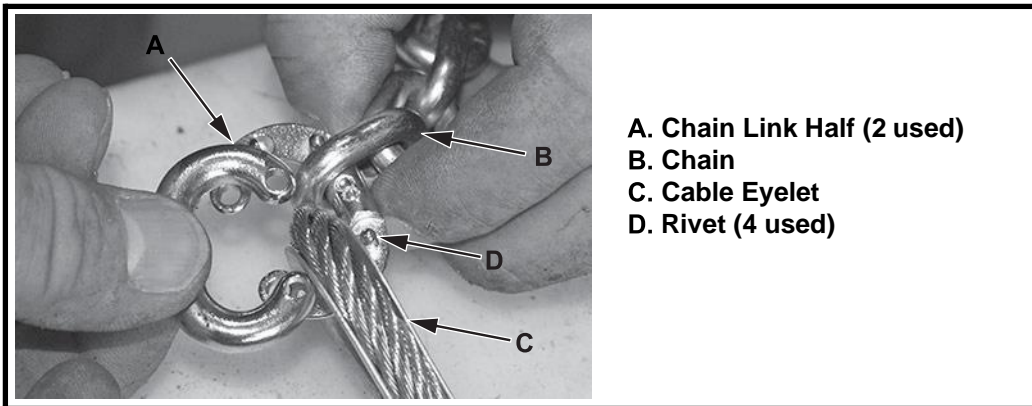
### DANGER

#### Automatic start-up of the conveyor

Serious or fatal injuries due to unintentional start-up of the conveyor.

- *Switch off the conveyor before starting work and secure it against being switched on again.*
- *Follow safe procedures to prevent unintentional restart.*

1. If breakaway links break:
  - a) Inspect cleaner and conveyor to determine cause of breakage.
  - b) Install new links as follows:
    - (1) Install one half of chain link (A) onto chain (B) and cable eyelet (C).
    - (2) Install second half of chain link onto first half.
    - (3) Place link on solid surface and peen rivets (D) to lock chain link halves together
  - c) Remove all tools from maintenance area.
  - d) Start conveyor belt. Observe belt cleaner operation for several revolutions of the belt. Service or adjust belt cleaner as necessary to ensure proper belt cleaner operation.



- A. Chain Link Half (2 used)
- B. Chain
- C. Cable Eyelet
- D. Rivet (4 used)

*Figure 11 Replacing Breakaway Link*

## 8 Troubleshooting

---



### DANGER

#### Automatic start-up of the system

Serious or fatal injuries due to unintentional start-up of the system.

- *Switch off the system before starting work and secure it against being switched on again.*
- *Follow safe procedures to prevent unintentional restart.*



### WARNING

#### Flying objects

Objects left on or in the conveyor can fly around uncontrollably when the conveyor is switched on and can hit and injure persons.

- *Before switching on the conveyor, remove all foreign objects such as tools, devices, etc. from the belt!*



### NOTE

The cleaners are used for different bulk materials and demanding working and environmental conditions.

Errors and malfunctions can therefore occur in addition to those listed below. Please contact the manufacturer in such cases.

Symptom	Corrective Action
Insufficient cleaning and carryback.	<p>Check to see that cleaner is contacting the belt across the front edge of the cleaner.</p> <p>Recheck mounting dimensions and adjust as necessary.</p> <p>Ensure tensioner spring is not totally collapsed and watch for chute flex.</p>
Belt is cleaner on one side than the other.	<p>Check installation, ensure cleaner is properly mounted and make any adjustments.</p> <p>Cleaner is likely out on one side and needs to be moved closer to the belt, re-tension cleaner (see Figure 9).</p>
Blade dancing or vibration.	<p>Check installation, ensure cleaner is properly mounted and make any adjustments.</p> <p>Cleaner is likely out on one side and needs to be moved closer to the belt, re-tension cleaner as described above (see Figure 9).</p> <p>Check tension on tensioner gauge to be sure of proper tension.</p> <p>Reset tension according to tensioning charts. Ensure blade is installed at proper angle.</p> <p>Ensure cleaner is centered on the belt and excess cable or chain on either side of belt does not exceed 125 mm (5 in.).</p> <p>Ensure chute wall is not flexing. Increase support as necessary.</p>
Cleaner is catching on mechanical splice.	<p>Check that outer 3–4 elements are off the belt to allow for the splice to flow through the cleaner without catching. Increase gap as necessary to allow splice to pass.</p>
Material builds up in gaps.	<p>Remove any excess material and check to ensure cleaner is properly located.</p> <p>Ensure bottom rope is properly positioned, adjust bottom rope on bottom side away from conveyor slightly by rotating bottom bracket.</p> <p>This will increase gap and allow material to be discharged more easily.</p> <p>Add more tension. Increase difference between tension on top and bottom rope to 15%.</p>
Breakaway link or cable break	<p>Check of belt if any damages at the edges or splice(es) did catch the blade or cables.</p> <p>Check if an overflow blockage happened and the sensor did not cause an emergency stop.</p> <p>Fit in new cable(s) and or breakaway link and reintegrate the cleaner.</p> <p>Test run and monitoring by 5 belt circulations is mandatory.</p>



---

## NOTE

---

Conveyor equipment such as conveyor belt cleaners are subject to a wide variety of bulk materials characteristics and often have to perform under extreme operating or environmental conditions.

It is not possible to predict all circumstances that may require troubleshooting. Contact Martin Engineering or a representative if you are experiencing problems other than those listed in the “Troubleshooting” chart above.

Do not return the equipment to operation until the problem has been identified and corrected.

## 9 Disassembly / Recycling / Disposal

---

1. Disassemble cleaners by material groups as far as possible.
2. Contact official bodies (disposal centres, authorities) and request information about proper disposal or recycling possibilities.
3. Recycle the different materials.

Only materials that cannot be reasonably recycled may be disposed of. Disposal must be carried out professionally.

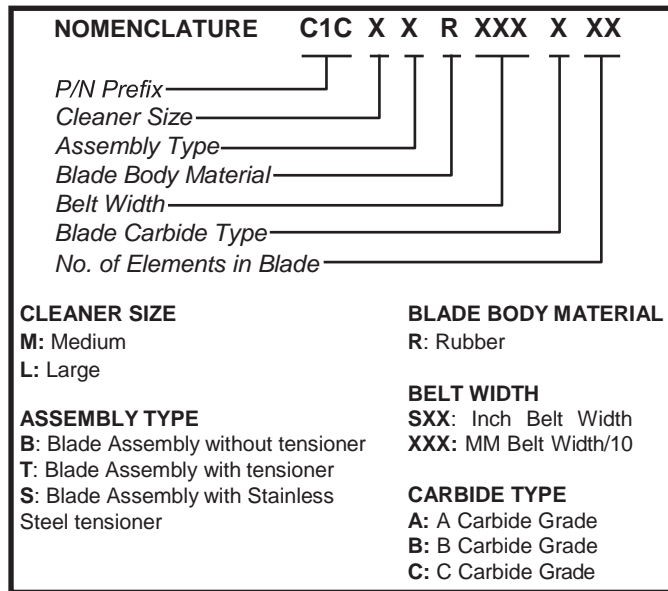
Material groups that can be fed into a recycling process include:

- Sheet steel
- Steel profiles
- Plastics
- Rubber
- Non-ferrous metals
- Electrical cables
- Electrical components (with copper content)
- Lubricants

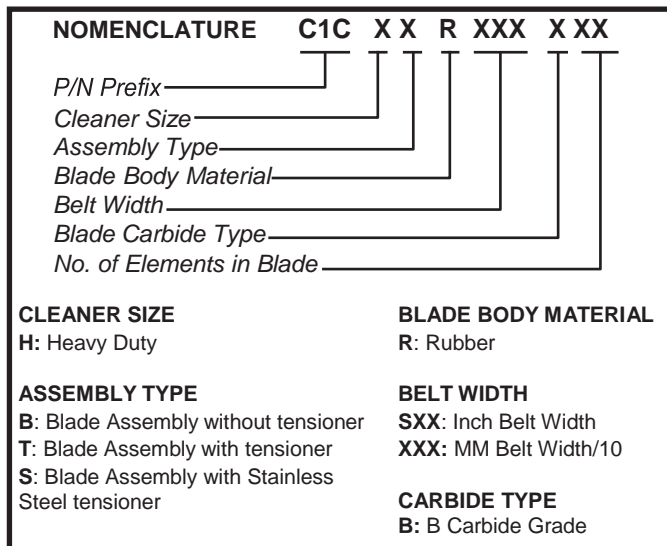
## 10 Part Numbers

This section provides product names and corresponding part numbers for CleanScape® Cleaners and related equipment. Please reference part numbers when ordering parts:

### CleanScape® Large and Medium Cleaner



### CleanScape® HD Cleaner:



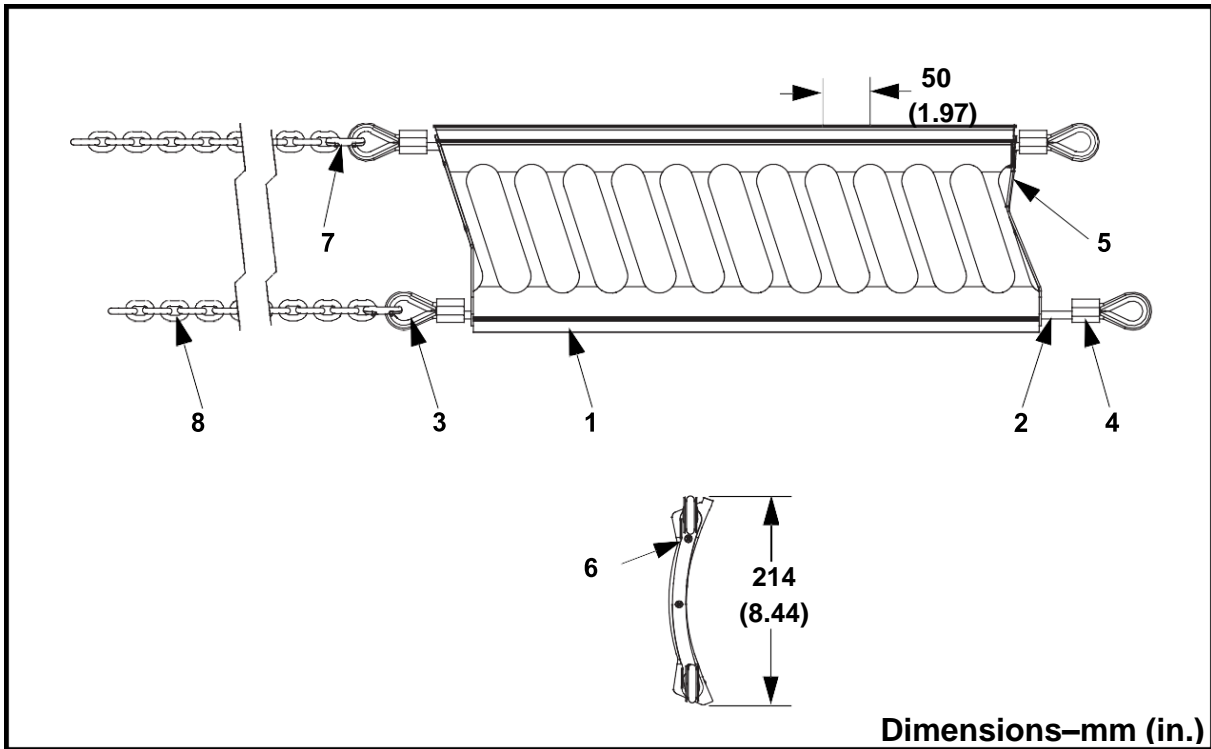


Figure 12: CleanScrape® Medium Cleaner, P/N C1CMXRXXXXXX

Item	Description	Part No.
1	Blade 50mm LG Element	C1CBCMX
2	Wire Rope 8mm SS	Table III
3	Wire Rope Thimble for 8mm Cable	C1CP5101XS
4	Swage Sleeve for 8mm Cable	C1CP51011C
5	End Safety Plate	C1CP50002S
6	Screw Wood #6 x 3/4 316 SS	39367
7	Chain Safety Link 8mm SS	C1CP51001S
8	Chain	C1CP51002T
9 (NS)	Installation Kit	Table III
10 (NS)	Adapter Kit for Wide Chute Wall	C1CP30000X

NS = Not Shown

Table III. Part Numbers for CleanScrape® Medium Cleaner

Number of Elements	Part No. Item 2	Part No. Item 9
29 and Below	C1CP51008S	C1CT4MX (Single 4.2kN)
30 thru 39	C1CP51009S	C1CT4DX (Dual 4.2kN)



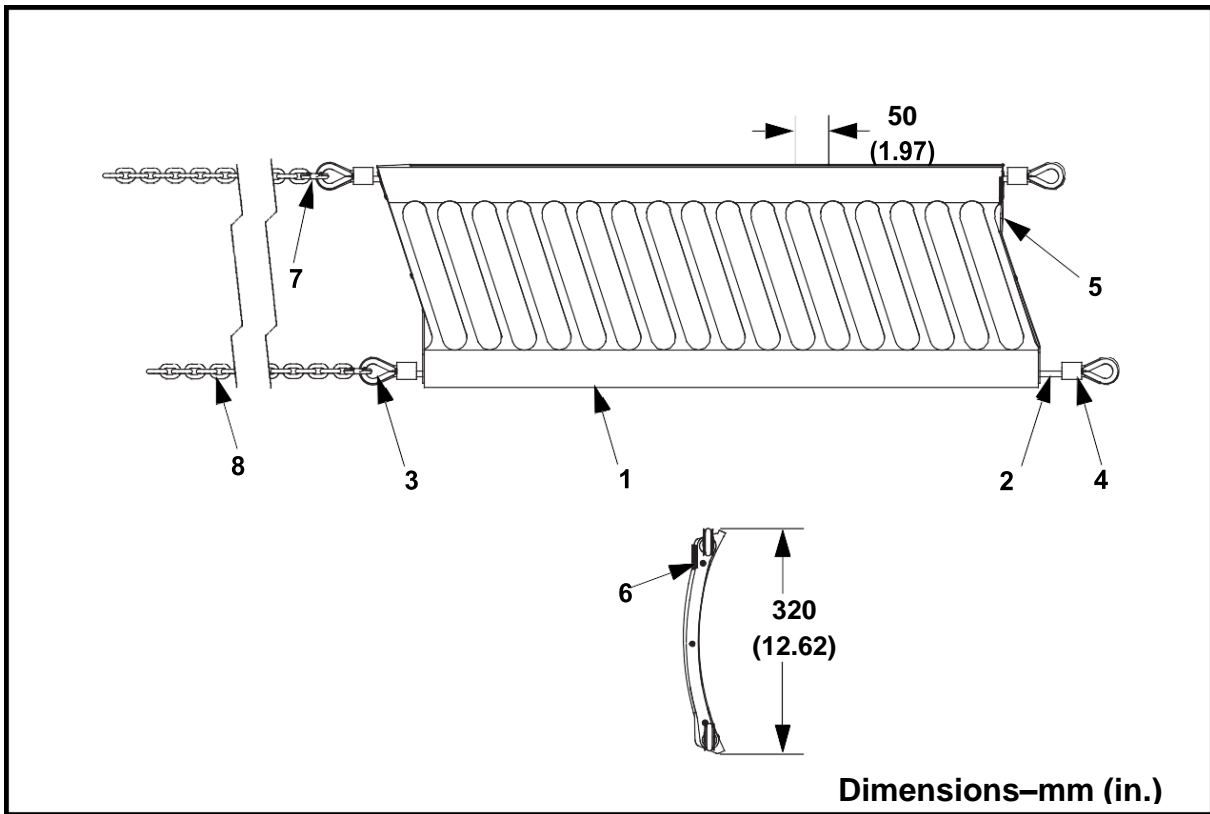


Figure 13: CleanScape® Large Cleaner, P/N C1CLRXXXXXX

Item	Description	Part No.
1	Blade 50mm LG Element	C1CBCLX
2	Wire Rope 8mm SS	Table IV
3	Wire Rope Thimble for 8mm Cable	C1CP5101X S
4	Swage Sleeve for 8mm Cable	C1CP51011 C
5	End Safety Plate	C1CP50003S
6	Screw Wood #6 x 3/4 316 SS	39367
7	Chain Safety Link 8mm SS	C1CP51001S
8	Chain	C1CP51002T
9 (NS)	Installation Kit	Table IV
10 (NS)	Adapter Kit for Wide Chute Wall	C1CP30000X

NS = Not Shown

**Table IV. Part Numbers for CleanScape® Large Cleaner**

Number of Elements	Part No. Item 2	Part No. Item 9
29 and below	C1CP51008S	C1CT4LX (Single 4.2kN)
30 thru 39	C1CP51009S	C1CT4DX (Dual 4.2kN)
40 thru 52		C1CT6DX (Dual 6.6kN)

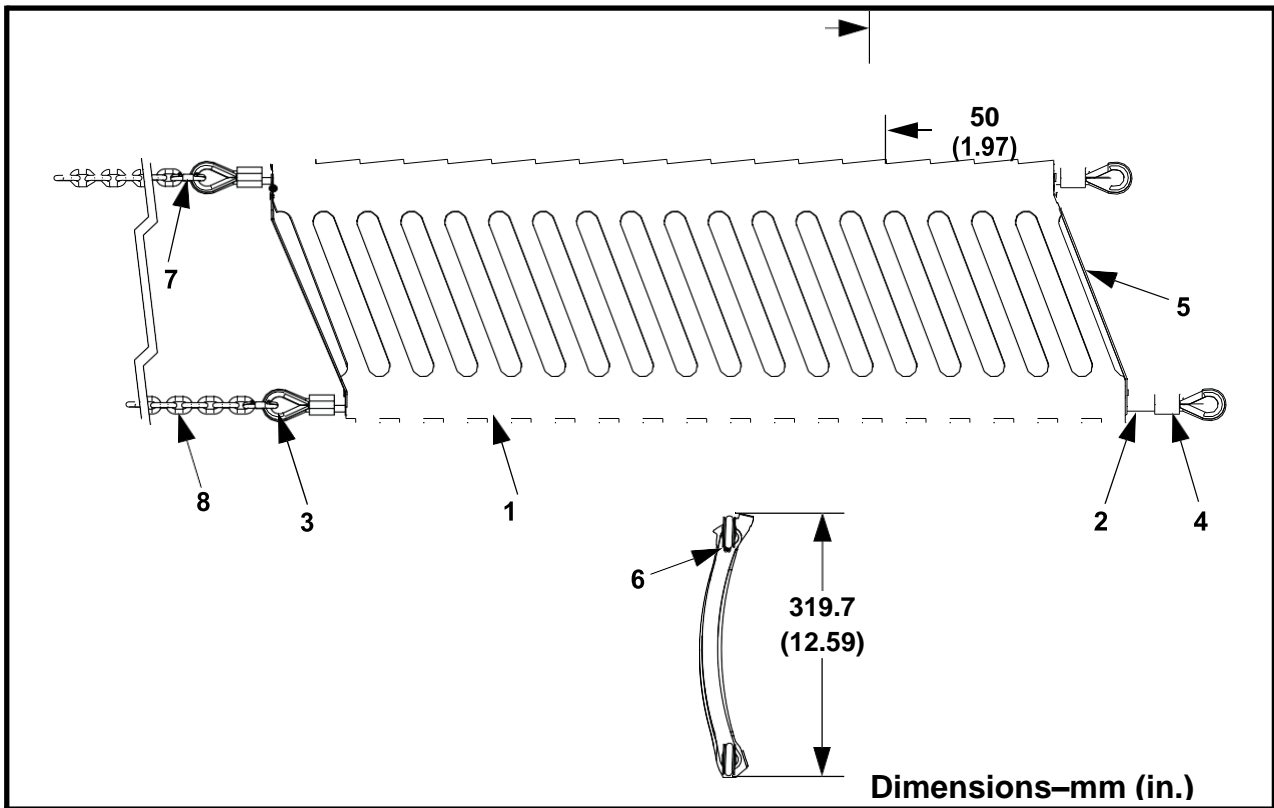


Figure 14: CleanScrape® HD Cleaner, P/N C1CHXRXXXXXX

Item	Description	Part No.
1	Blade 50mm HD Element	C1CBCHB
2	Wire Rope 8mm SS	Table V
3	Wire Rope Thimble for 8mm Cable	C1CP5101XS
4	Swage Sleeve for 8mm Cable	C1CP51011C
5	End Safety Plate	C1CP50003S
6	Screw Wood #6 x 3/4 316 SS	39367
7	Chain Safety Link 8mm SS	C1CP51001S
8	Chain	C1CP51002T
9 (NS)	Installation Kit	Table V
10 (NS)	Adapter Kit for Wide Chute Wall	C1CP30000X

NS = Not Shown

Table V. Part Numbers for CleanScrape® HD Cleaner

Number of Elements	Part No. Item 2	Part No. Item 9
29 and below	C1CP51008S	C1CT4LX (Single 4.2kN)
30 thru 39	C1CP51009S	C1CT4DX (Dual 4.2kN)
40 thru 61		C1CT6DX (Dual 6.6kN)

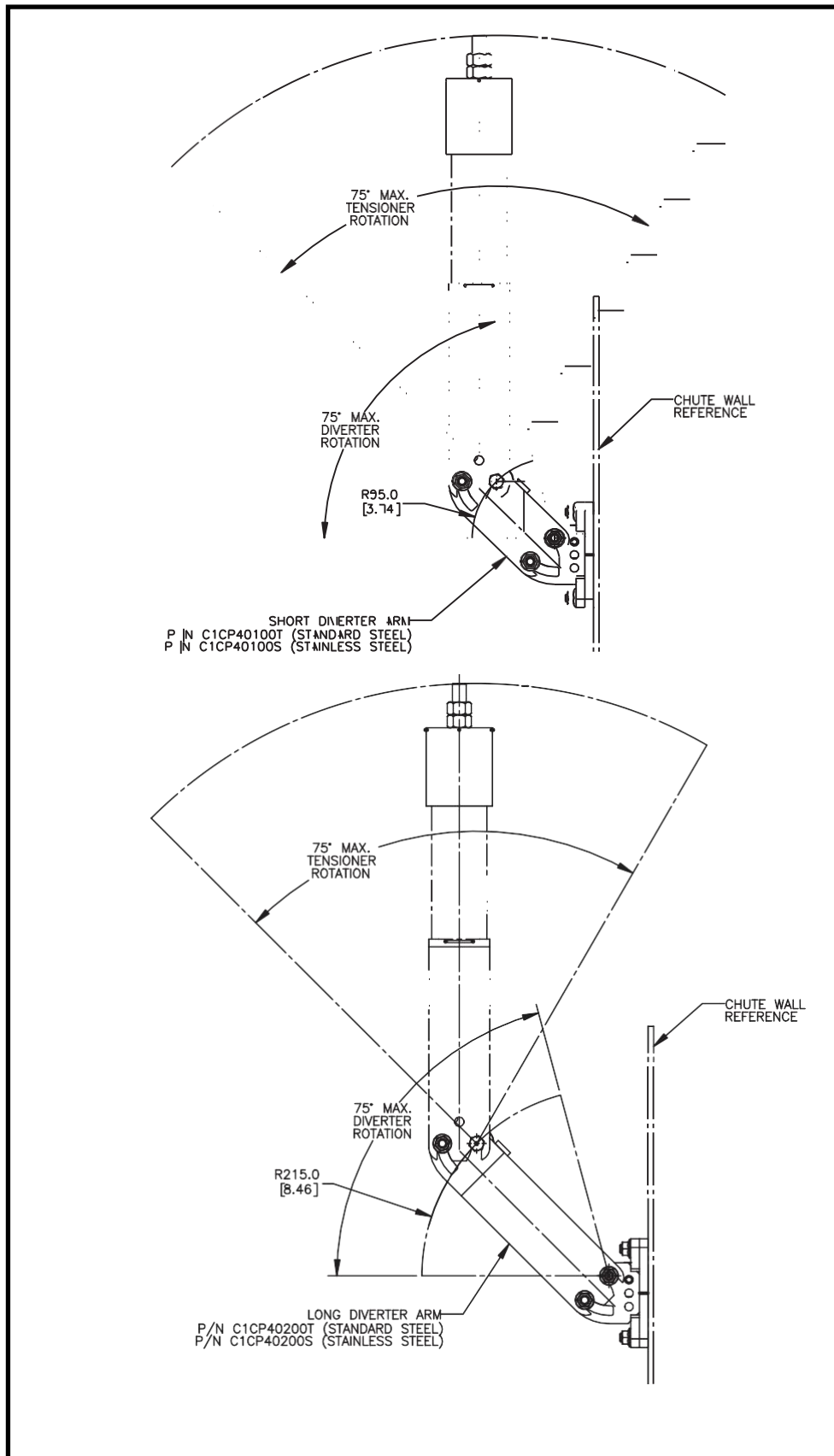


Figure 15: Optional Diverter Arms

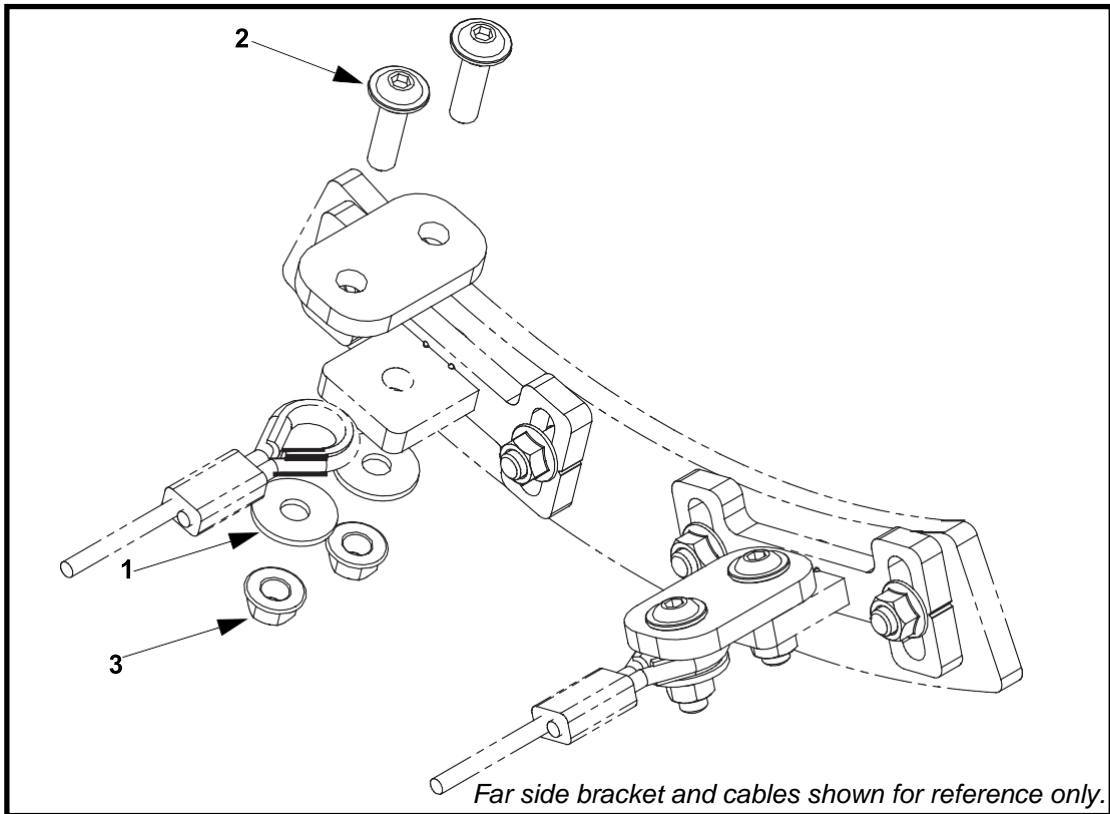


Figure 16: Wide Chute Wall Adapter Kit, P/N C1CP30000X\*

Item	Description	Part No.	Qty.
1	Washer Flat 10mm Fender	Table IV	4
2	Screw SBFH M10 x 1.5 x 35	Table IV	4
3	Nut Hex Serrated Flange M10 x 1.5	Table IV	4

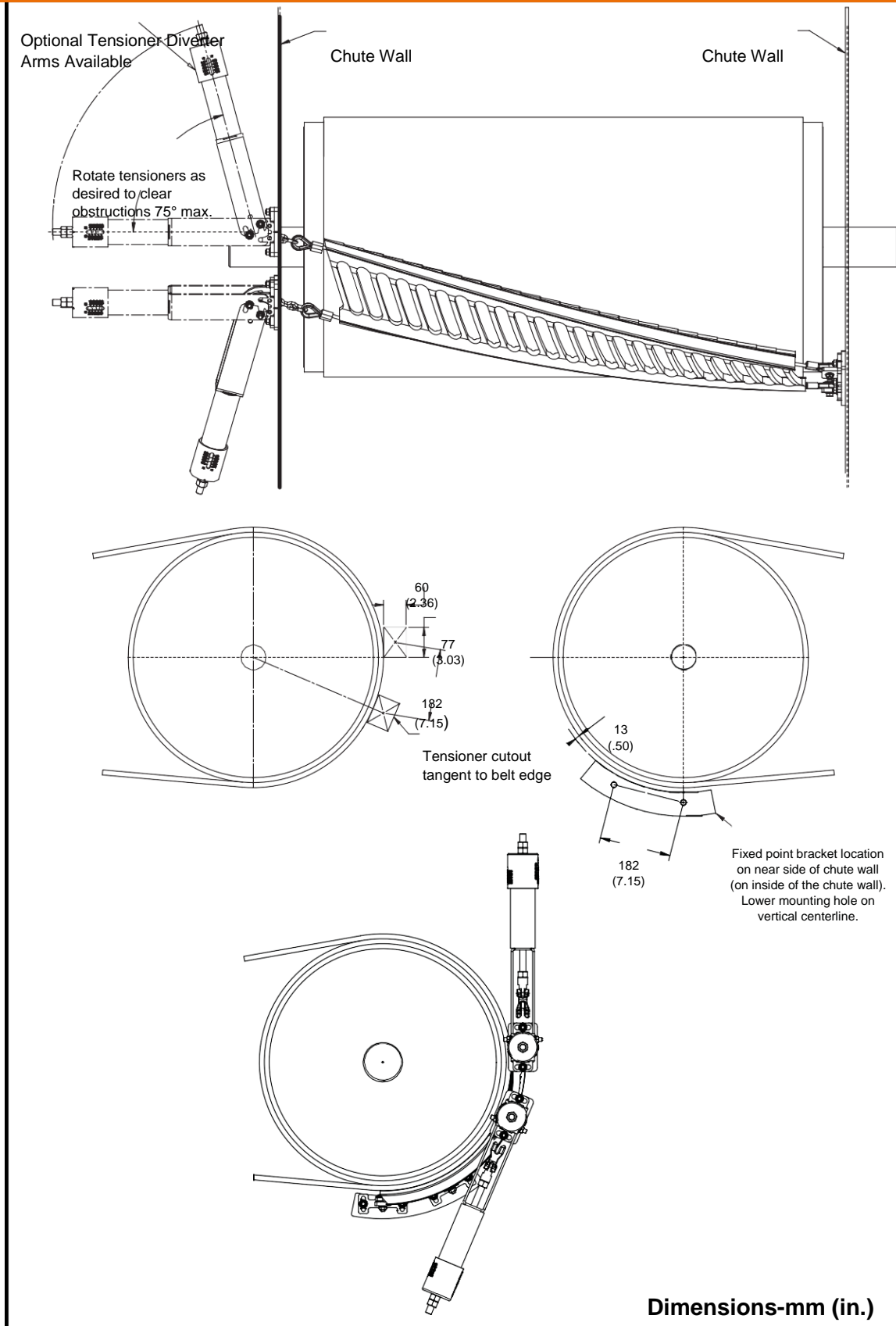
Table VI. Part Numbers for Wide Chute Wall Adapter Kit

Assembly Part No.	Part No. Item 1	Part No. Item 2	Part No. Item 3
C1CP30000T	39492	39493	39491
C1CP30000S	39492-S	39493-S	39491-S

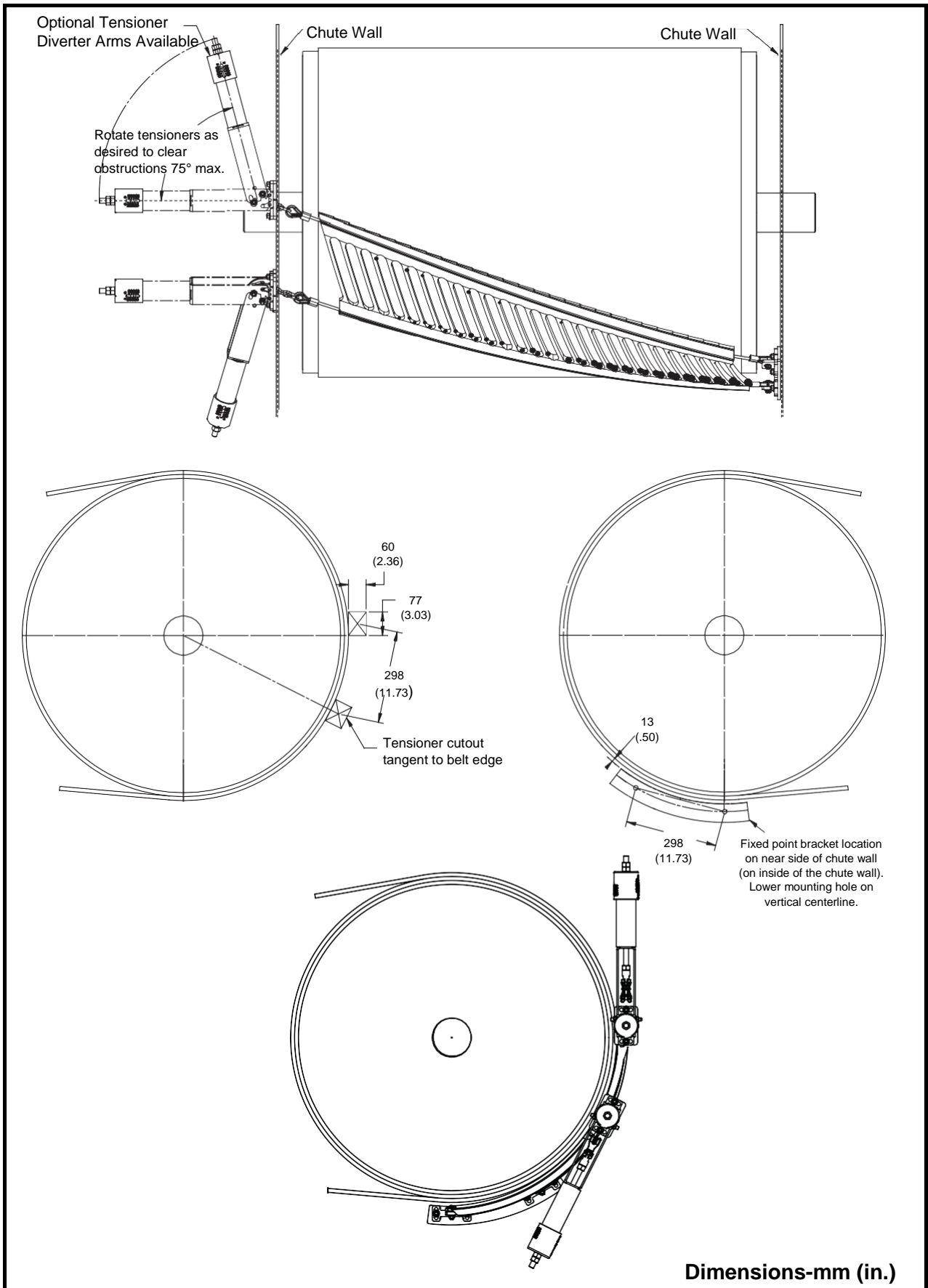


Figure 17: Warning Label

# 11 Appendix

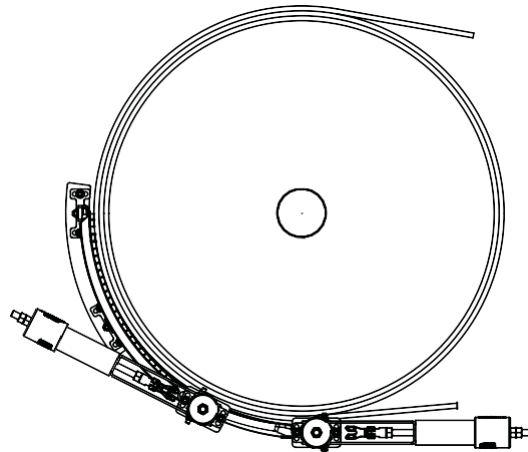
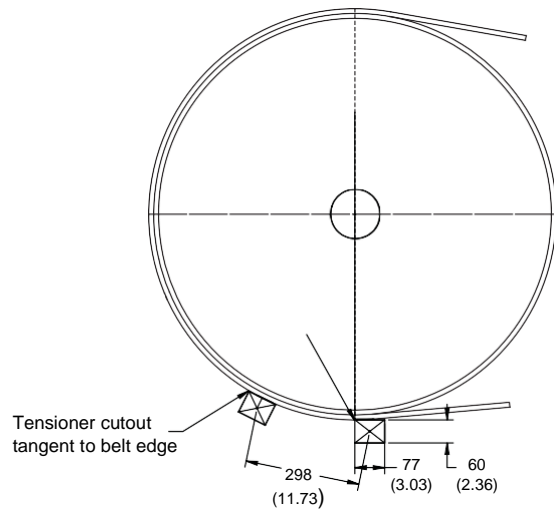
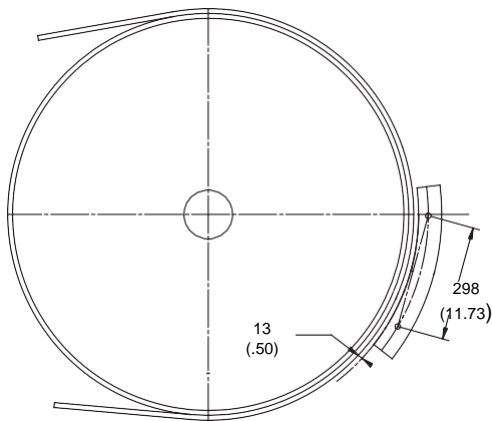
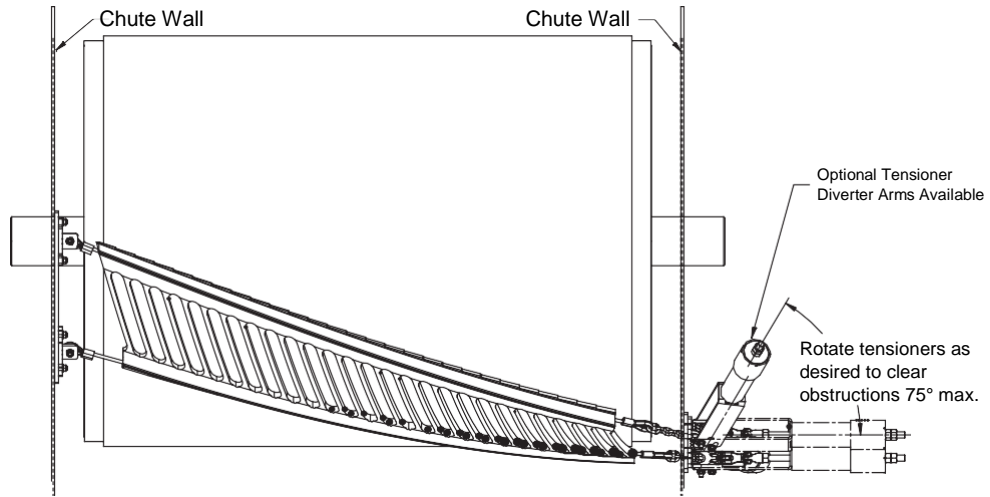


*Preferred Mounting Location for CleanScrape® Medium Cleaner*



**Preferred Mounting Location for CleanScrape® Large and HD Cleaners**

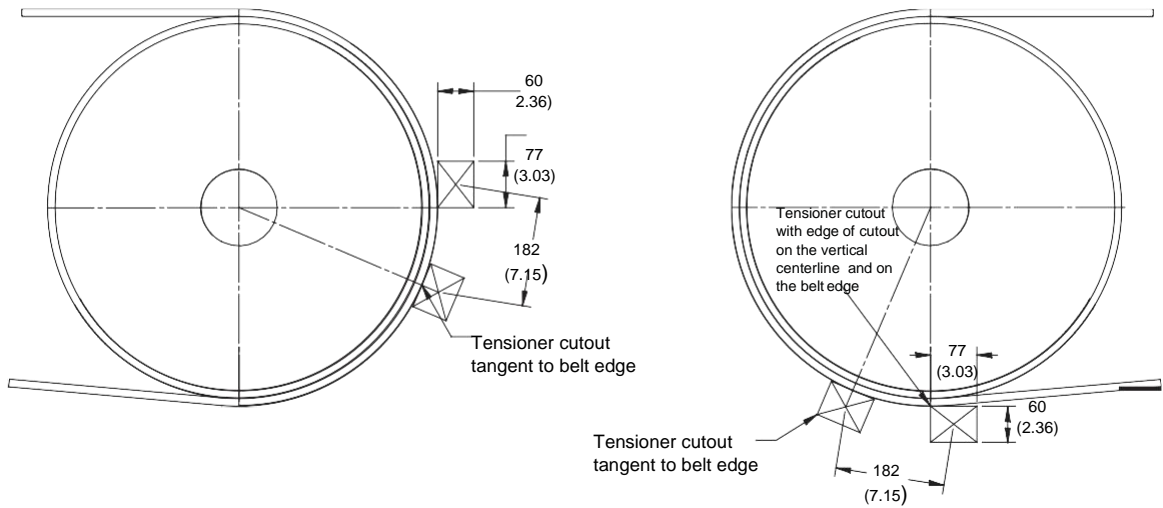
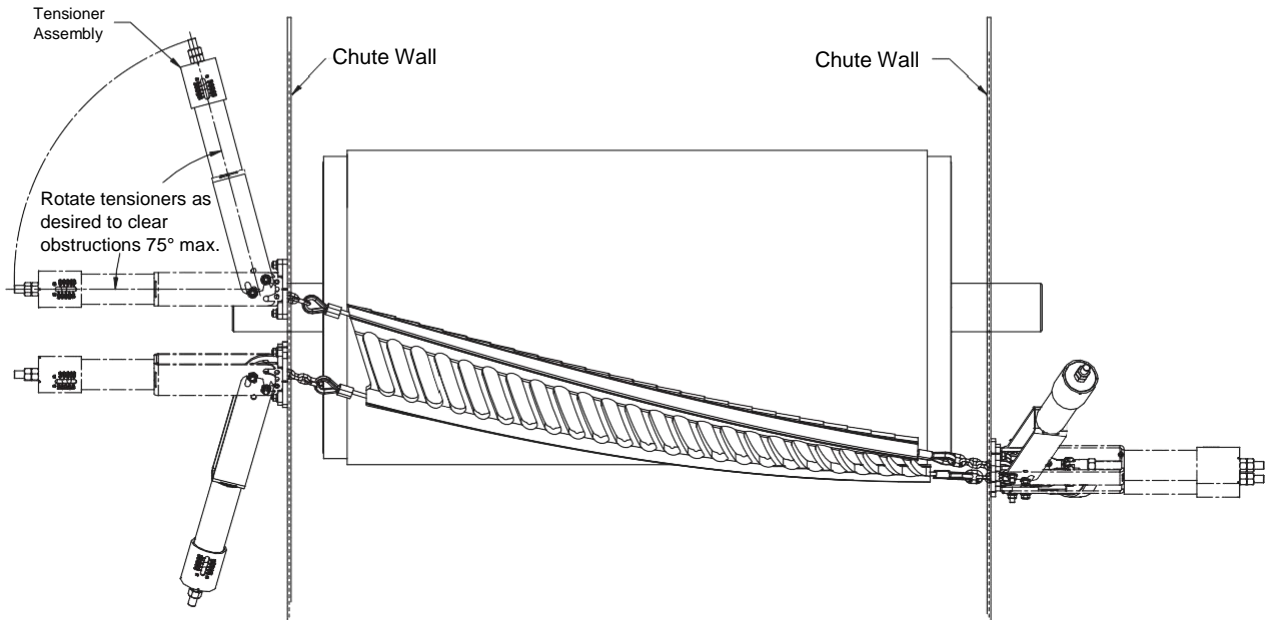
**Cleaner assembly with the tensioner at the bottom is not the preferred installation position.  
Use only when no other options are available.**



**Dimensions-mm (in.)**

**Bottom Side Tensioner Mounting for CleanScape® Large and HD Cleaners**

This assembly does not use a fixed point bracket.  
 Two tensioners are installed on the operator side chute wall  
 and two tensioners are installed on the far side chute wall.

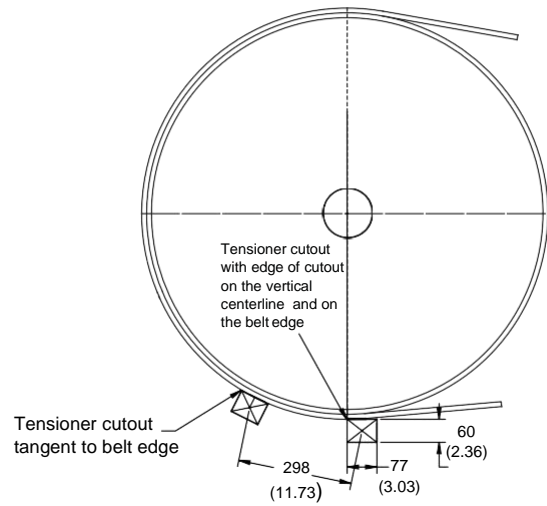
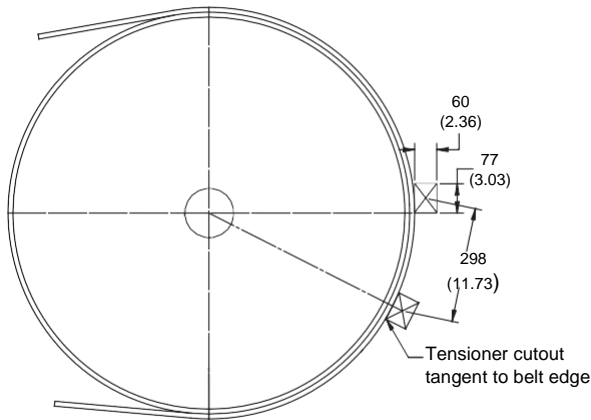
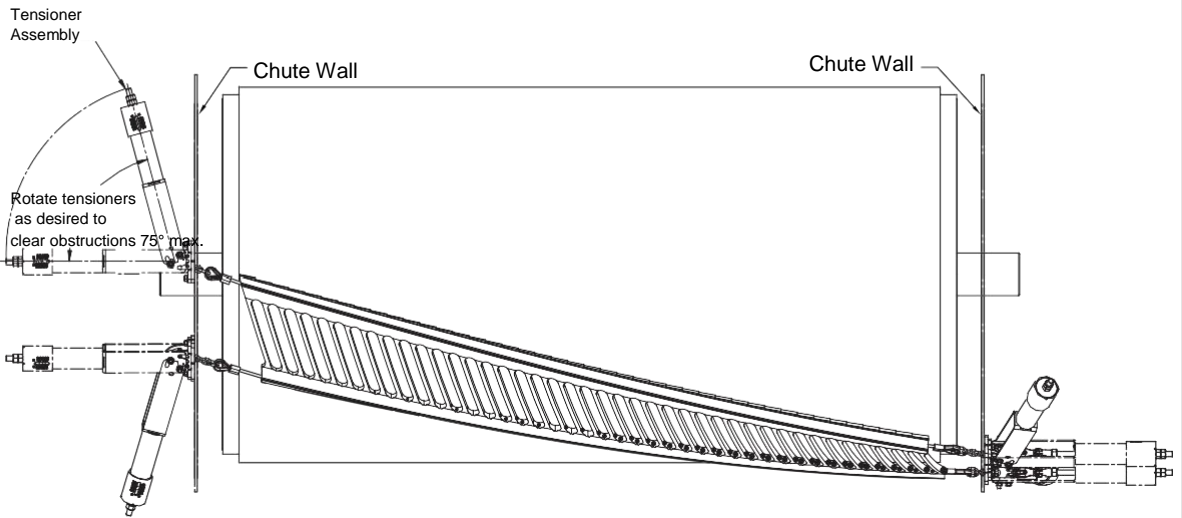


Dimensions-mm (in.)

**Mounting Location for CleanScrape® Medium Cleaner Requiring Tensioners on Both Sides**



**This assembly does not use a fixed point bracket.  
Two tensioners are installed on the operator side chute wall  
and two tensioners are installed on the far side chute wall.**



**Dimensions-mm (in.)**

**Mounting Location for CleanScape® Large and HD Cleaners**

**Requiring Tensioners on Both Sides**

## Contact :

### India

**Martin Engineering Company India Pvt. Ltd.**

Plot No. 191, 192, 193,

Vadu Khurd, Alandi-Markal Road,

Phulgaon, Pune 412 216

Tel +91 20 66788270

[salesindia@martin-eng.com](mailto:salesindia@martin-eng.com) | [www.martin-eng.in](http://www.martin-eng.in)