

Pre-cleaner and secondary cleaner

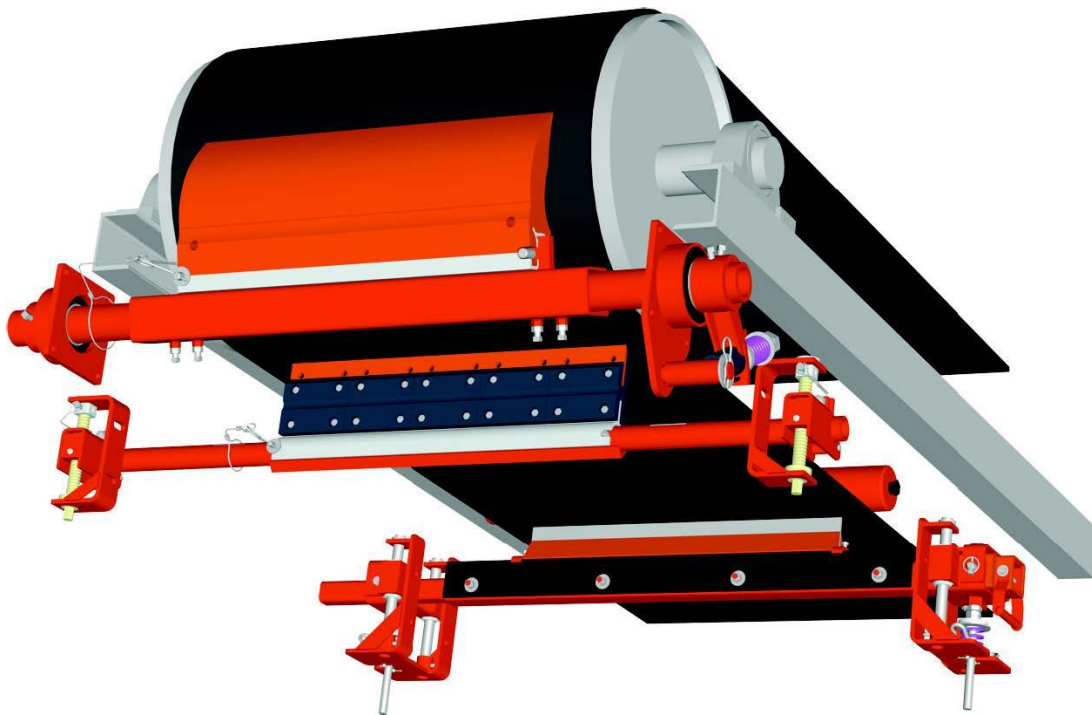

Operating Instructions Part 1 - General

Version: 0

M9000EUK-05/20

Table of Contents

1	General.....	1
2	Safety	5
2.1	General safety instructions	5
2.2	Personal protective equipment	6
2.3	Safety markings on the system.....	6
2.4	Special safety instructions for usage in ATEX areas	7
3	Preparations before installation	8
3.1	Required maximum of tools and materials.....	8
3.2	Checking the operating conditions.....	9
3.3	Unpacking/transportation.....	9
4	Installation	10
4.1	Identification of the correct installation position	11
4.2	Mounting position for the tensioner.....	12
4.3	Shortening the mainframe	12
4.4	Installation of cleaners and tensioners.....	13
4.5	Tension against the conveyor belt.....	14
5	Operation.....	15
5.1	General notes	15
5.2	Requirements	16
5.3	Commissioning	16
6	Maintenance/servicing/repair.....	18
7	Troubleshooting and repair.....	19
7.1	General notes	19
7.2	Troubleshooting.....	20
7.3	Replacing the blades	21
8	Spare parts.....	22
9	Disassembly/recycling/disposal.....	22

1 General



NOTE

Before starting work on the cleaner or the conveyor, part 1 and 2 of these operating instructions must be read and understood completely

1.1 About these operating instructions

These operating instructions apply solely for cleaners and are intended for those persons who install cleaners, commission them, and monitor their usage. The operating instructions must be kept for the lifetime of the cleaners and must be made available in an orderly condition to all persons entrusted with work with and on the cleaners.

1.2 Accompanying documents

Part 2 of the operating instructions, which is provided separately, is an integral part of these operating instructions.

1.3 Illustrations in the operating instructions

All illustrations are schematic representations and make no claim to completeness. The illustrations show pre-cleaners and are intended to clarify the relevant facts. The same facts also apply to secondary cleaners.

1.4 General information on cleaners

Cleaners are used in the discharge area of the belt conveyor to remove adhering bulk material from conveyor belts. The cleaning result is increased by using multiple cleaners.

Pre-cleaners are installed at the head pulley, below the discharge parabola of the bulk material.

Secondary cleaners are installed behind pre-cleaners when viewed in the direction of belt travel and are used for fine cleaning of the conveyor belts. The typical installation position is behind the discharge pulley, but still inside the chute enclosure.

These operating instructions describe actions and measures for the use of cleaners on closed discharge enclosures of the conveyor. If the discharge area of the conveyor is not enclosed, the operator must take precautions to ensure that the cleaners can be relocated, installed, maintained and repaired in the same way.

Furthermore, the operator must ensure that all necessary protective measures for safe operation of the system with cleaners have been taken.

Cleaners must be easy to check, clean and maintain. Appropriate means of access must be provided for this purpose.

1.5 Intended usage

Cleaners are used for mechanical removal of bulk material sticking on conveyor belts with smooth surfaces. They may only be used:

- in the industrial area above ground
- on the carrying side of the conveyor belts
- according to the technical data in the documentation
- in the installation position as described in the documentation

The usage of the cleaners is only considered to be as intended if the following conditions are also fulfilled:

- Before starting initial work, the personnel must have been instructed on the work on the system and on all relevant issues of occupational health and safety
- Any personal protective equipment required must be worn
- The provisions of the operating instructions must be observed in full.

Operation of the cleaners under deviating conditions and unauthorised modification of the cleaners is considered as improper usage.

1.6 Use in hazardous areas according to the ATEX directive

The standard version of the cleaner is NOT suitable for use in hazardous areas.

Martin Engineering offers special product variants that are suitable for use in ATEX zones 22 and 21 under certain circumstances. These product variants contain mandatory additional components or have special product characteristics.

Special instructions for the use of cleaners in ATEX zones must be observed.

Requirements for the use of these special product variants:

- Minimum ignition energy of the bulk material: >10 mJ
- Belt connections are vulcanised
- There are no substances in the bulk material which could generate impact sparks on the cleaners.
- Coatings (corrosion protection) have standard layer thicknesses (max.80µm)
- Earthing cables are properly installed (Bleeder resistance < 10⁶Ω)

In particular, the instructions in part 2 of the operating instructions must be observed, such as:

- Information on the ATEX marking of the cleaners
- Details of the product-specific components and their design features

1.7 Personnel qualification

Only authorised and qualified personnel may be entrusted with work with and on the conveyors and cleaners. Persons are considered qualified if they have the qualification of a skilled worker and meet all the following requirements:

- completed professional training or at least 5 years of professional experience in the field,
- technical experience,
- knowledge of the relevant occupational health and safety regulations.

The persons must

- be able to assess the tasks and risks assigned to them,
- be able to recognise potential dangers in advance,
- be physically and cognitively able to operate the conveyors and cleaners safely,
- have been trained and instructed appropriately,
- have read and understood these operating instructions.

Work on earth connections, cabling, switching, control, regulation, automation and all electrical components may be carried out only by trained electricians.

1.8 Technical data

For information on technical data, see part 2 of the operating instructions.

1.9 Requirements for the usage site

For information on the required spatial requirements of the cleaner and the tensioner, see part 2 of the operating instructions.

2 Safety

2.1 General safety instructions



DANGER

Entanglement in conveyor belt

Clothing or body parts can become entangled in the conveyor and cause serious or fatal injuries.

Tensions may be released in the conveyor belt and cause movement of the bulk material without prior detection.

- *Do not carry out any work on the conveyor belt while it is in operation or reach into the moving conveyor belt!*
- *Secure the conveyor against unintentional restart! Use lockout / tagout / blockout / testout procedures!*
- *Install suitable guards to prevent access to the infeed section!*



WARNING

Danger of injury due to unapproved component parts

Unapproved parts can directly or indirectly cause personal injury or damage to property.

- *Only use accessories and spare parts that are distributed by the manufacturer or are explicitly approved (in writing)!*



WARNING

Working in confined spaces

Areas in which cleaners are installed are often difficult to access and include confined spaces. It is often necessary to work in difficult positions.

- *Determine whether occupational safety measures are necessary that go beyond the usual measures!*



WARNING

Risk of falling down





Cleaners are often mounted and operated in heights. There may be a risk of falling down.

- *Therefore, use a fall protection device when installing in higher working areas!*

2.2 Personal protective equipment

Persons carrying out work on cleaners must wear suitable personal protective equipment.

Minimum requirements:

Symbol	Meaning
	Wear head and eye protection.
	Wear at least ankle-high foot protection.
	Use gloves.
	Use fall protection.

2.3 Safety markings on the system

The safety markings on the cleaners must be kept in good condition and clearly visible at all times.

If parts of the system are replaced, ensure that the spare parts are or will be provided with appropriate warning signs.

2.4 Special safety instructions for usage in ATEX areas



DANGER



Usage in ATEX zones 22 and 21

Combustible dust can cause explosions and thus cause serious or fatal injuries.

- *Ensure that all explosion-related parameters and operating modes are observed.*
- *Observe all instructions for usage in hazardous areas.*
- *Ensure that the bulk material meets the specified requirements before the conveyor is switched on.*
- *Ensure that the cleaners are suitable for all explosion-related parameters and operating modes of the application.*
- *Ensure that the conveyor belts do not have any metallic connectors. All belt connections must be vulcanised.*
- *Ensure that the bulk material is free of foreign substances that could create an ignition source for the dust/air mixture.*
- *Ensure that any necessary metal-separating devices are operating effectively.*
- *Install cleaners in such a way that no metal part can contact moving components even when the blade is completely worn.*
- *Use only tools and aids that are approved for use in the respective ATEX zone.*
- *Ensure that the cleaners are tensioned against the conveyor belt with the maximum forces / tension values specified.*
- *Ensure that the earth connections of the cleaners are installed correctly.*
- *Use only cleaners as special product variants that are suitable for use in potentially explosive areas.*
- *Measure the gas and dust content of the environment before using open flames.*
- *Prevent electrostatic charges, for example by cleaning plastic enclosures with a dry cloth.*
- *Work on earth connections, cabling, switching, control, regulation, automation and all electrical components may be carried out only by trained electricians.*

3 Preparations before installation

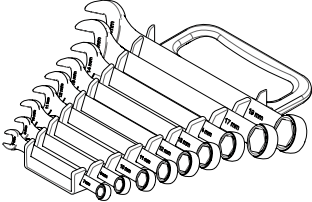
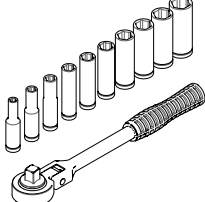
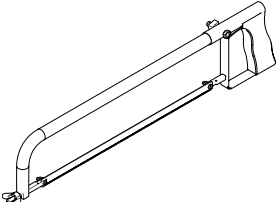
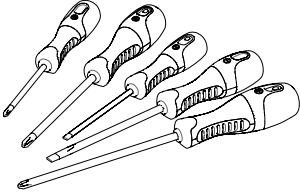
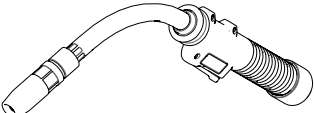
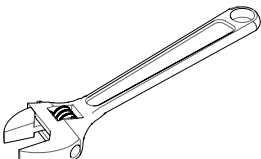
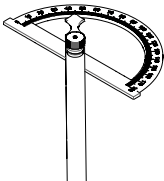
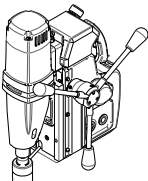
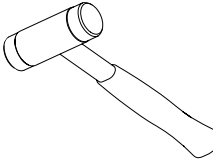
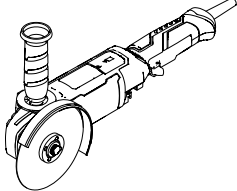
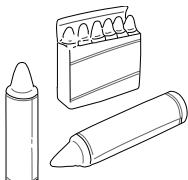
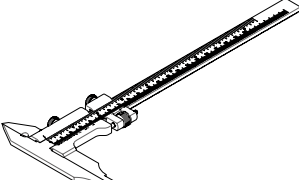
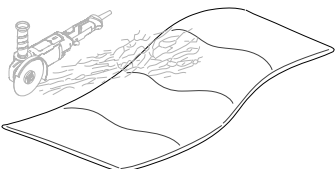
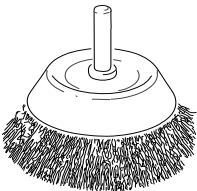
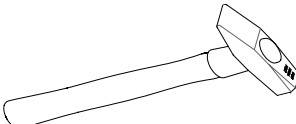
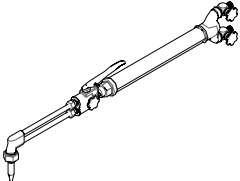
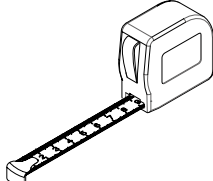
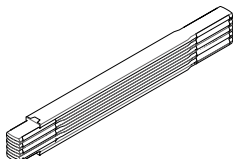
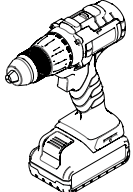
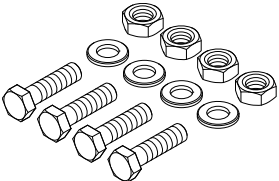
3.1 Required maximum of tools and materials

3.2 Checking the operating conditions

Before installation, check whether the cleaner is suitable for the application. For this purpose, it must be ensured that:

- the available space allows unobstructed installation, maintenance and repair of the cleaner,
- the cleaner meets the requirements for the respective operation (ambient conditions, operating mode of the conveyor, properties of the bulk material, fire protection, explosion protection, etc.)
- special product variants are used if the cleaners are operated in ATEX zones 22 and 21 and all explosion-related parameters and operating modes are observed.

3.3 Unpacking/transportation



WARNING

Heavy weight

The cleaners may have weights that require handling by lifting devices. Handling heavy cleaners by hand can cause serious skeletal injuries.

- *Use suitable aids if the load is > 25 kg per person!*
- *Identify the centre of gravity! Ensure that the cleaner cannot tilt during the lifting process!*

When unpacking, all components must be checked for completeness and intactness.

4 Installation



DANGER

Entanglement in conveyor belt

Clothing or body parts can become entangled in the conveyor and cause serious or fatal injuries.

Tensions may be released in the conveyor belt and cause movement of the bulk material without prior detection.

- *Do not carry out any work on the conveyor belt while it is in operation or reach into the moving conveyor belt!*
- *Secure the conveyor against unintentional restart! Use lockout / tagout / blockout / testout procedures!*
- *Install suitable guards to prevent access to the infeed section!*



DANGER

Automatic start-up of the conveyor

Serious or fatal injuries due to unintentional start-up of the conveyor.

- *Switch off the conveyor before starting work and secure it against being switched on again.*
- *Follow safe procedures to prevent unintentional restart.*



WARNING

Heavy weight

The cleaners may have weights that require handling by lifting devices. Handling heavy cleaners by hand can cause serious skeletal injuries.

- *Use suitable aids if the load is > 25 kg per person!*
- *Identify the centre of gravity! Ensure that the cleaner cannot tilt during the lifting process!*

4.1 Identification of the correct installation position



NOTE

The correct installation position of the cleaner and the tensioner can be found in part 2 of the operating instructions.

- *Ensure that the specified installation positions are fully observed.*
- *Ensure that maintenance of the cleaner can be carried out without problems.*
- *Provide the required possibilities for inspection and maintenance.*

Notes on pre-cleaners with polyurethane blades:

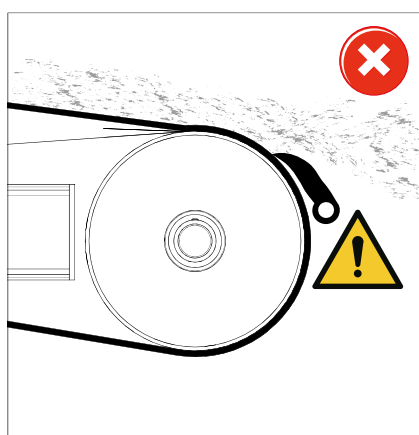

The pre-cleaners can be installed at various positions on the pulley as long as the correct distance between the mainframe and the belt surface is maintained.

The installation position of the pre-cleaner can be rotated around the pulley.

Borders are:

- the discharge trajectory
- material accumulation between blade and belt.

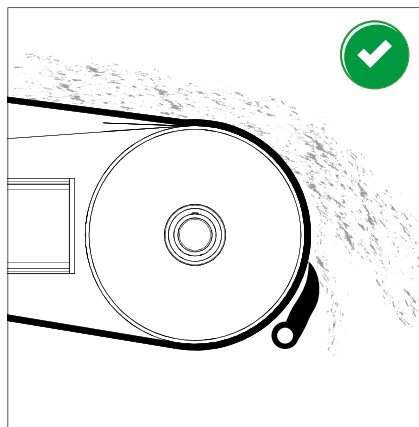
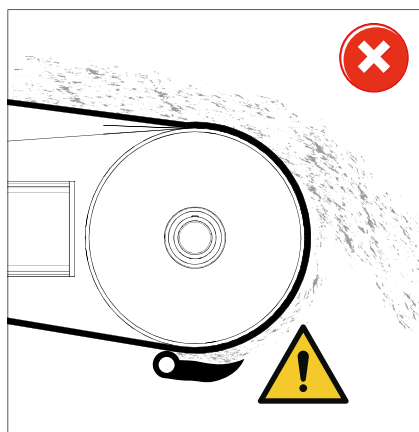

4.2 Mounting position for the tensioner



NOTE

To guarantee trouble-free operation, ensure that:

- *the cleaner is installed in the centre of the conveyor belt,*
- *the blade(s) is/are parallel to the belt surface.*

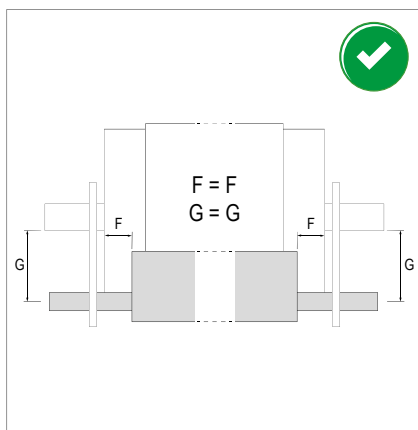

1. Determine the exact installation positions as specified in part 2 of the operating instructions.
2. Mark the appropriate position of the cleaner and its mainframe on the chute wall.
3. Mark the appropriate position of the tensioner on the chute wall.

4.3 Shortening the mainframe



NOTE

Shortening of the mainframe is applicable for cleaners with a mainframe that is not telescopic and if the cleaner does not have a “trac-mount” function.



NOTE

When shortening, the width of the tensioner must be taken into account. It must be possible to insert the mainframes of the cleaners at a sufficient depth into the tensioners and fix them there.

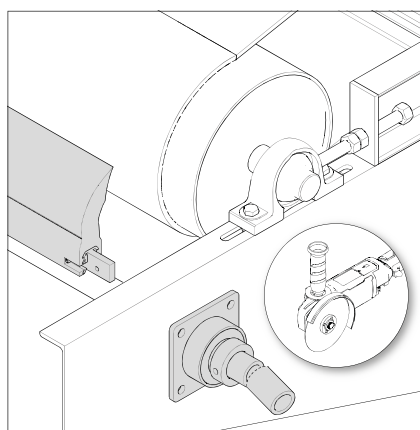

1. Determine the length of the mainframe.
2. Shorten the mainframes by sawing or angle grinding.

4.4 Installation of cleaners and tensioners



NOTE

Some cleaners require only one tensioner for smaller belt widths. In such a case, a counter bearing is provided on the opposite side for supporting the mainframe.

The bearing has the same drill hole positions as the tensioner.

For product-specific information, see part 2 of the operating instructions.

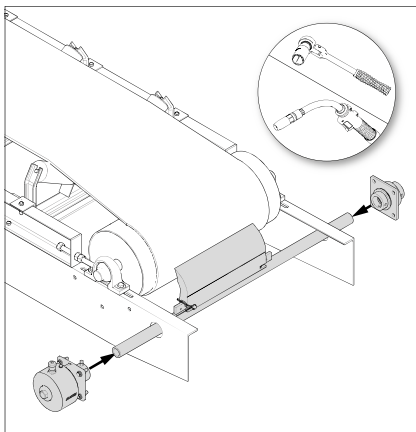

1. If necessary, disassemble the tensioner so that it can be attached to the chute wall.
2. Screw (preferred) or weld the support plates of the tensioner to the chute walls.
3. Install the cleaners and attach the mainframe to the tensioners.
4. Check the tensioners, the counter bearings, the mainframe and the blades for secure fixing.
5. Attach the supplied labels to the specified positions.

Applicable for special product variants for use in potentially explosive atmospheres:

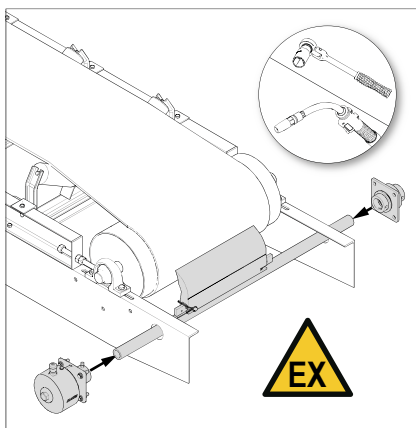

6. Install all included accessories, such as earthing cables, for cleaners and tensioners.
7. Ensure that the Bleeder resistance of all components of the cleaners is $< 10^6 \Omega$

For further information, see technical rules for hazardous substances (Technische Regeln für Gefahrstoffe, TRGS 727).

4.5 Tension against the conveyor belt



NOTE

The correct tension depends on the width of the cleaner.

The values specified for the voltage of the cleaners are based on operation with bulk materials.

There is a label on the tensioner that provides information on the correct tension of the cleaner against the conveyor belt.

An illustration of the labels can be found in part 2 of the operating instructions.

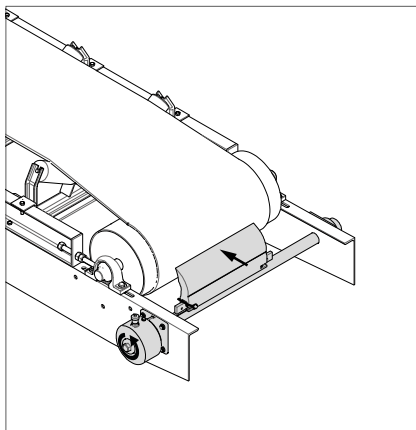

1. Adjust the tensioner according to the information on the labels.

5 Operation

5.1 General notes



DANGER

Entanglement in conveyor belt

Clothing or body parts can become entangled in the conveyor and cause serious or fatal injuries.

Tensions may be released in the conveyor belt and cause movement of the bulk material without prior detection.

- *Do not carry out any work on the conveyor belt while it is in operation or reach into the moving conveyor belt!*
- *Secure the conveyor against unintentional restart! Use lockout / tagout / blockout / testout procedures!*
- *Install suitable guards to prevent access to the infeed section!*
- *Do not leave any foreign substances, tools, scaffolding, aids, etc., which could cause hazards, in the area of the conveyor.*



DANGER

Risk of explosion

The use of unsuitable cleaners and the non-observance of specific instructions and regulations for use in potentially explosive atmospheres can cause explosions and personal injury.

- *Use only cleaners as special product variants that are suitable for use in potentially explosive areas!*
- *Ensure that the cleaners are suitable for all explosion-related parameters and operating modes of the application!*
- *Observe all instructions for usage in hazardous areas!*



WARNING

Flying objects

Objects left on or in the conveyor can fly around uncontrollably when the conveyor is switched on and can hit and injure persons.

- *Before switching on the conveyor, remove all foreign objects such as tools, devices, etc. from the belt!*

5.2 Requirements

- Cleaners and all associated components are installed correctly.
- The conveyor and its safety devices are in perfect condition.

5.3 Commissioning



NOTE

Stop operation of the cleaner and conveyor immediately if:

- unusual noises or vibrations occur,
- the blades are in the bulk material stream, or bulk material has built up on the blades.

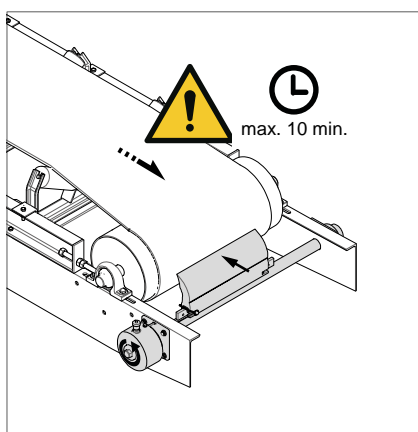

1. Observe the operation of the cleaners during commissioning.
2. Operate the cleaner without bulk material for max. 10 minutes.
3. Observe the cleaner in continuous operation with bulk material for the first 60 minutes.

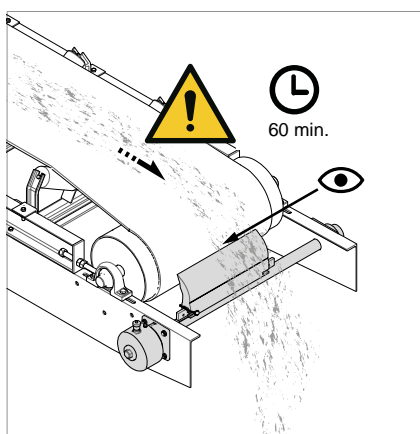

5.3.1 Blades made of PU and conveyor belts in brand new condition



NOTE

If the blades made of PU or the conveyor belt are in a brand-new condition and the conveyor is operated without bulk material, the frictional forces increase. This can lead to excessive heating and damage to the blades.

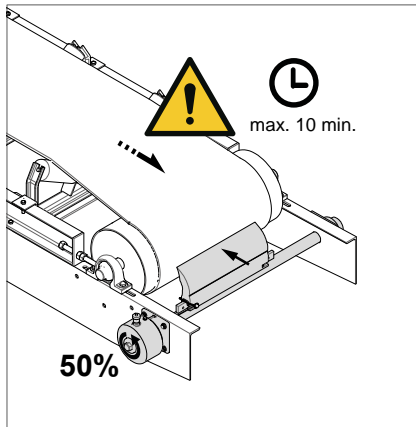

1. Adjust the tensioner to 50% of the tensioning force as indicated on the labels.
2. Operate the conveyor for a maximum of 10 minutes to carry out a test without bulk material.
3. Increase the tension to 100% as soon as there is bulk material on the conveyor belt.

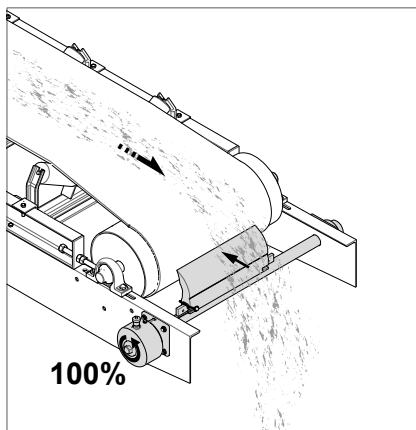

6 Maintenance/servicing/repair

Interval	Component part	Activity
Daily	Cleaner	<ul style="list-style-type: none"> Visual inspection for dirt and wear, remove dirt if necessary, replace worn components
	Tensioner	
	Labels	
Weekly	Cleaner	<ul style="list-style-type: none"> Check tension, re-tension if necessary. Check the screw connections for tight fit. Tighten any loose connections.
	Tensioner	<ul style="list-style-type: none"> Check the screw connections for tight fit. Tighten any loose connections.

Additional requirements applicable for EX area:

Interval	Component part	Activity
Daily	Cleaner	<ul style="list-style-type: none"> Visual inspection of earth connections
	Tensioner	
Monthly	Cleaner Tensioner	<ul style="list-style-type: none"> Verify and ensure that the earth leakage resistance of all components of the cleaners is $< 10^6 \Omega$

7 Troubleshooting and repair

7.1 General notes



DANGER

Automatic start-up of the system

Serious or fatal injuries due to unintentional start-up of the system.

- *Switch off the system before starting work and secure it against being switched on again.*
- *Follow safe procedures to prevent unintentional restart.*



WARNING

Flying objects

Objects left on or in the conveyor can fly around uncontrollably when the conveyor is switched on and can hit and injure persons.

- *Before switching on the conveyor, remove all foreign objects such as tools, devices, etc. from the belt!*



NOTE

The cleaners are used for different bulk materials and demanding working and environmental conditions.

Errors and malfunctions can therefore occur in addition to those listed below. Please contact the manufacturer in such cases.

7.2 Troubleshooting

Symptom	Cause	Remedy
High wear on the blades.	The cleaner is too tightly tensed on the conveyor belt.	Reduce the tension to the appropriate values.
Insufficient cleaning performance and material accumulation.	The cleaner is not tensed enough or is tensed too tightly on the conveyor belt.	Increase or reduce the tension.
	The cleaner is installed too high up on the head pulley and impairs the material flow.	Install the cleaner in a lower position.
	The blades are worn.	Inspect the blades and replace if necessary.
Unusual pattern of wear or damage to the blade.	Damaged conveyor belt or connection points.	Inspect the conveyor belt's connection point(s) and repair or replace as needed.
	Cleaner installed in the material flow.	Install the cleaner in a lower position.
	Different tension values of the tensioner.	Check the tension values and possibly re-tighten.
Noises or vibrations.	Cleaner force on the conveyor belt too light or too heavy.	Correct the tension if necessary.
	The blade's urethane is possibly not suitable for the application.	Contact Martin Engineering or a representative.
	Unsuitable installation position	Check the installation position of the cleaner and correct it according to the operating instructions of the cleaner. Should this not be successful: Replace blades with new ones. Should this not be successful: Contact Martin Engineering or a representative.
Warped or broken cleaner mainframe	Blade at or beyond the wear line.	Check the position of the cleaner mainframe and correct if necessary.
	Incorrect positioning of the mainframe	Replace blade.
Corrosion or chemical decomposition	The blade's urethane is possibly not suitable for the application	Contact Martin Engineering or a representative.

7.3 Replacing the blades

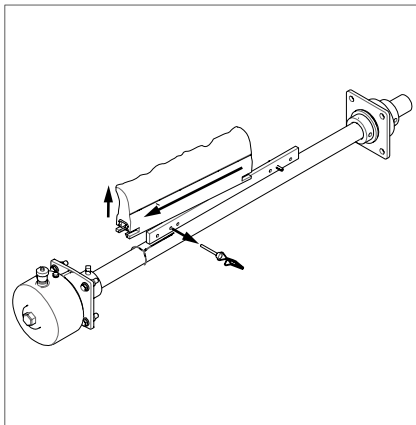

1. Slacken the Inline-Reversing tensioners as specified in the corresponding operating instructions.
2. Secure the cleaner against falling down.
3. Loosen the clamping connection between mainframe and tensioner.
4. Remove the tensioner(s) if necessary

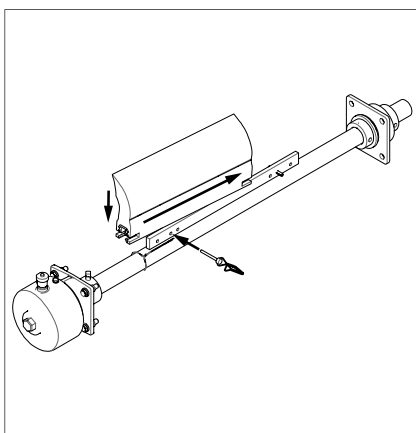

The following applies to cleaners with “Quick Change” (“QC”) or “Trac-Mount” (“TM”) function:

5. Detach the blade or cartridge of blades from the mainframe, move it to the side and replace the blade(s).
6. Slide the new blade or cartridge with the new blades onto the mainframe and fasten / lock it there.

The following applies to cleaners without “Quick Change” (“QC”) or “Trac-Mount” (“TM”) function:

7. Remove the cleaner and move it to a location where the blades can be changed safely.
8. Remove the blades and install new blades
9. Reinstall the cleaner.
10. Follow the instructions in the chapter “Installation of cleaners and tensioners” / “Correct tension against the conveyor belt” / “Operation”

8 Spare parts

For information on the spare parts of the cleaner and the tensioners, see part 2 of the operating instructions.

-
1. Disassemble cleaners by material groups as far as possible.
 2. Contact official bodies (disposal centres, authorities) and request information about proper disposal or recycling possibilities.
 3. Recycle the different materials.

Only materials that cannot be reasonably recycled may be disposed of. Disposal must be carried out professionally.

Material groups that can be fed into a recycling process include:

- Sheet steel
- Steel profiles
- Plastics
- Rubber
- Non-ferrous metals
- Electrical cables
- Electrical components (with copper content)
- Lubricants

Contact :

India

Martin Engineering Company India Pvt. Ltd.

Plot No. 191, 192, 193,

Vadu Khurd, Alandi-Markal Road,

Phulgaon, Pune 412 216

Tel +91 20 66788270

salesindia@martin-eng.com | www.martin-eng.in