

MARTIN® AIR CANNON NOZZLE SELECTION AND INSTALLATION GUIDE



Martin® Smart™ Series High-Temp Retractable Nozzle



Martin® Smart™ Series High-Temp Straight Y-Pipe Nozzle



Martin® Smart™ Series High-Temp Straight Nozzle

AMBIENT TEMPERATURE NOZZLES

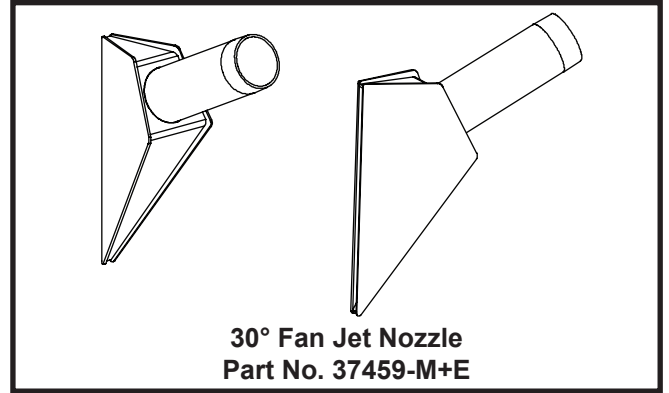
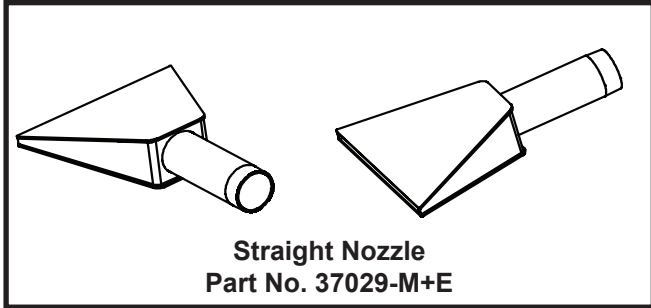
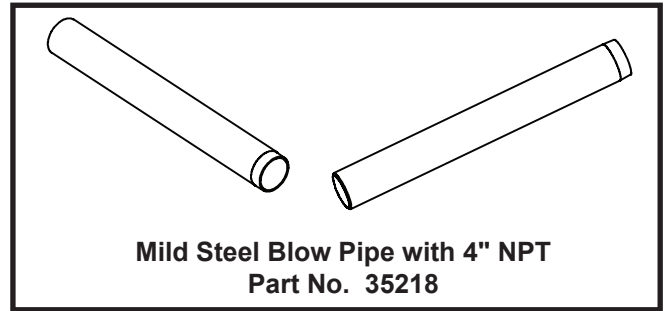
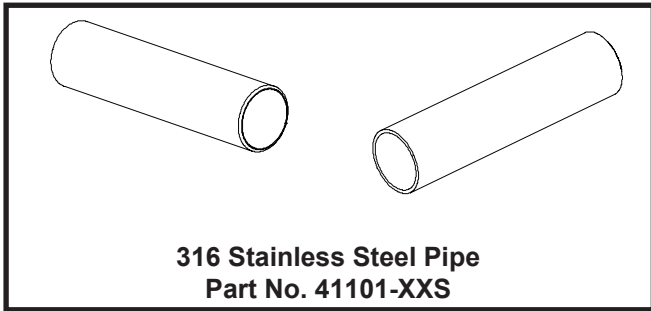
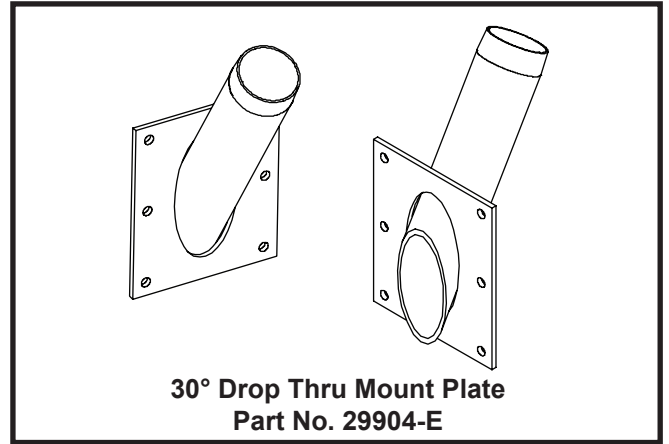
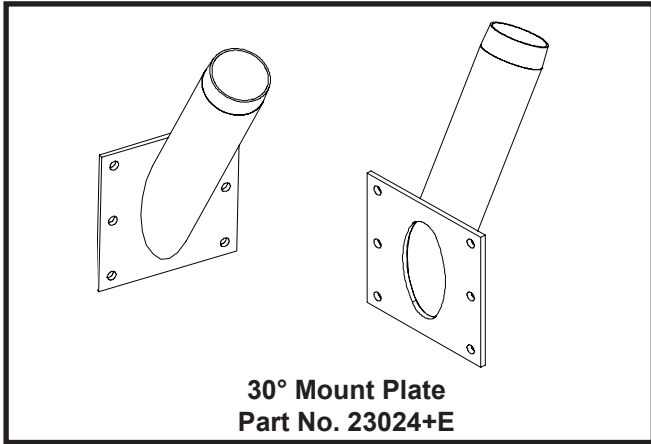

HIGH TEMPERATURE NOZZLES

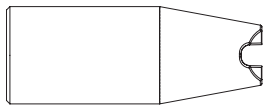

Compact Fan Jet Nozzle
Part No. 39431 (41350)

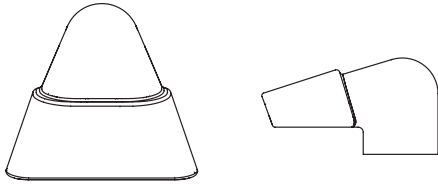

90° Fan Jet Nozzle
Part No. 29953+E

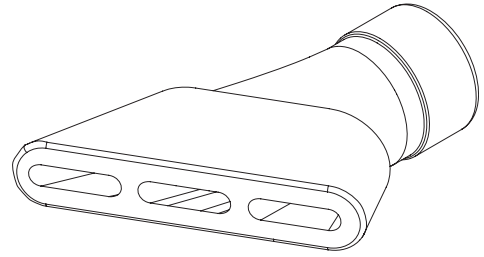

30° Fan Nozzle
Part No. 41367-XX

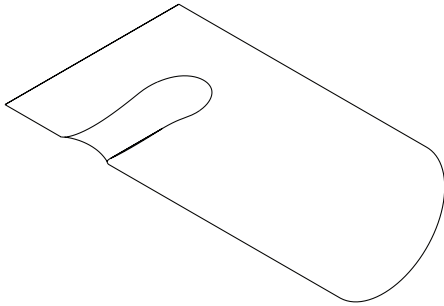

45° Jet Nozzle
Part No. 36366

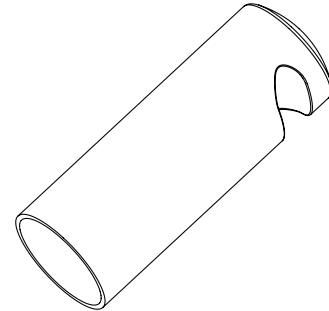

90° Jet Nozzle
Part No. A30001

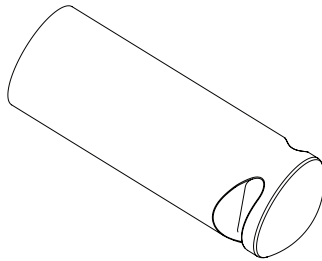

180° Jet Nozzle
Part No. A30002

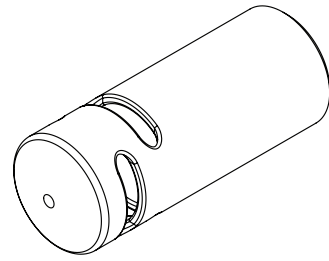

360° Jet Nozzle
Part No. 39519-N

MARTIN® SMART™ SERIES NOZZLE ASSEMBLIES

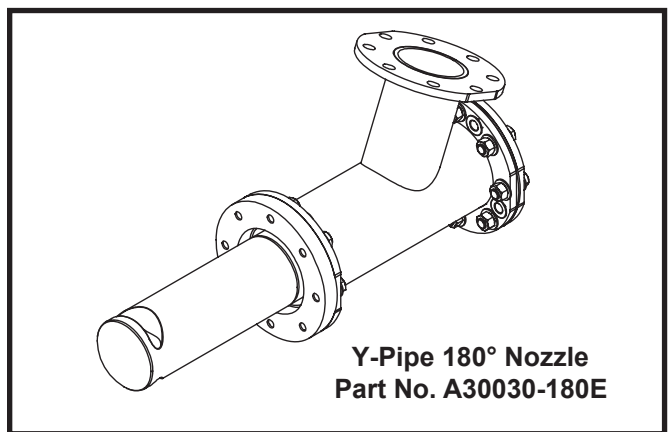
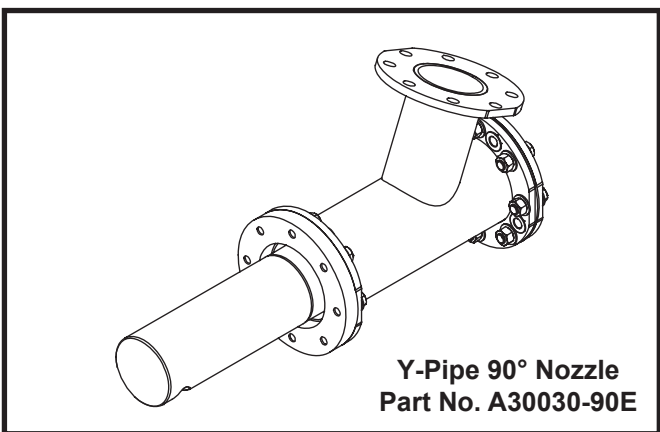
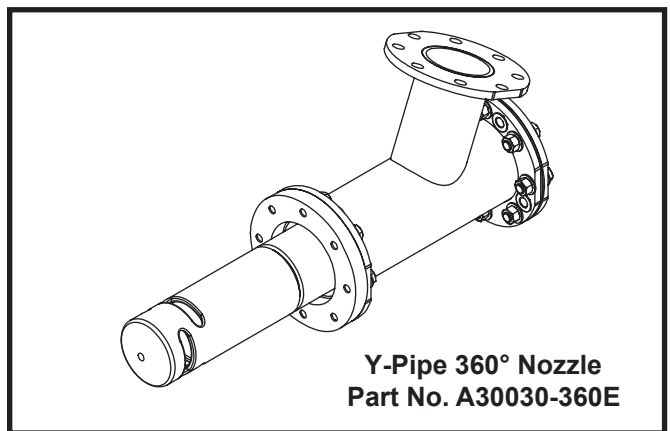
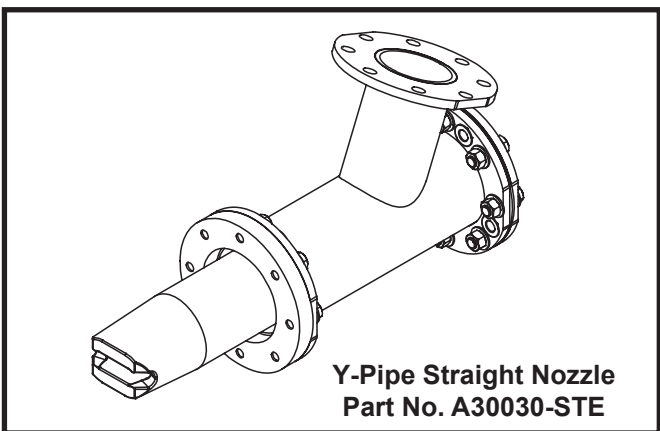
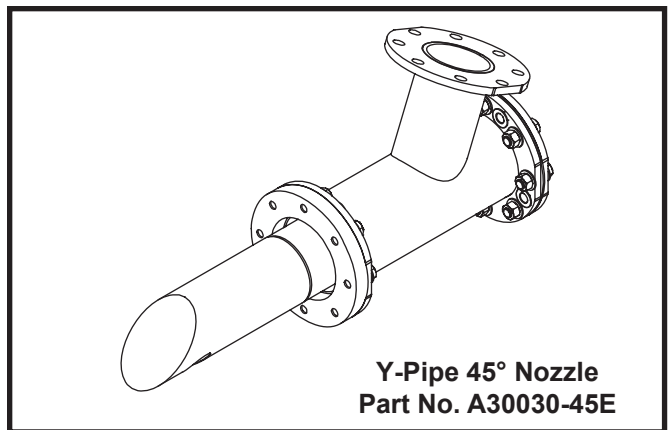
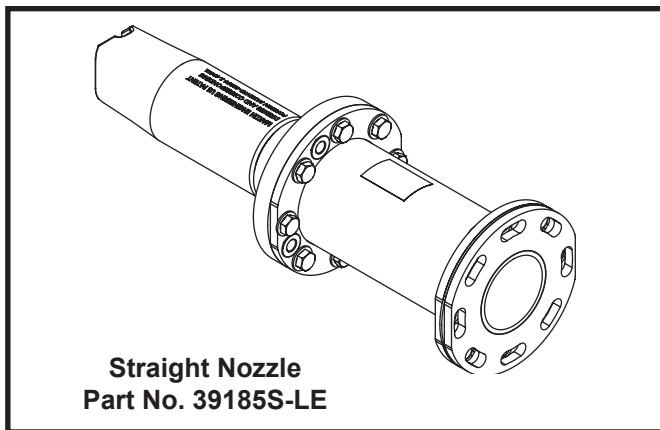
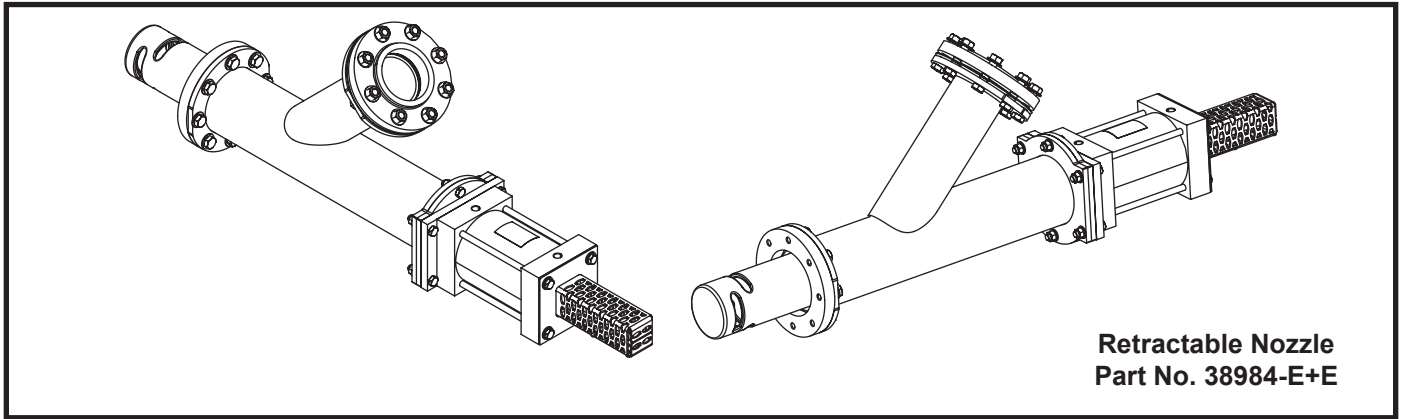

Problem Solved™ GUARANTEED!

Form No. L4150-05/22
© Martin Engineering Company 2020, 2022

CASTING AND REPLACEMENT WELDMENTS

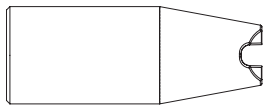

Compact Fan Jet Nozzle
Part No. 39431 (41350)

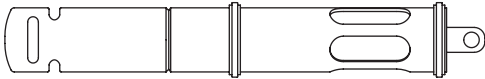

Retractable Nozzle
Part No. 38983-NWE

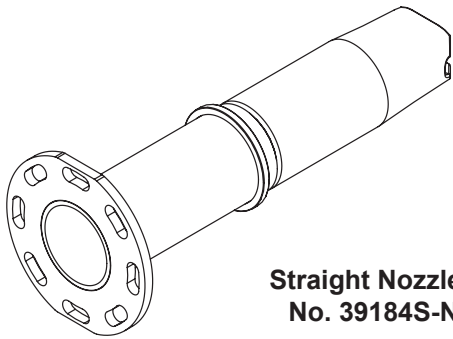

Straight Nozzle Part
No. 39184S-NWE

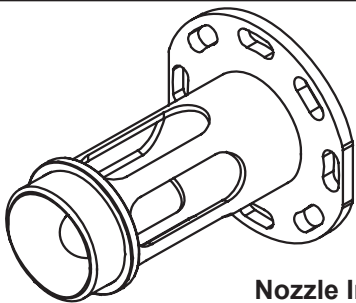

Nozzle Inlet Weldment
Part No. A30026-E

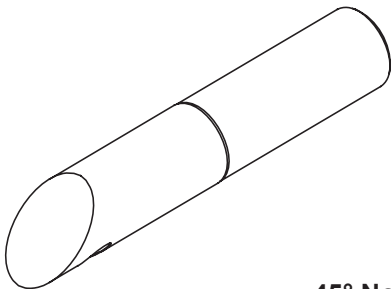

45° Nozzle
Part No. A30027-45E

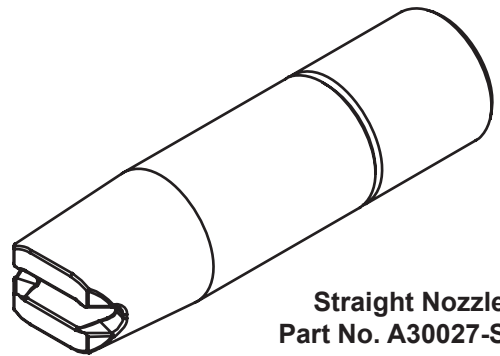

Straight Nozzle
Part No. A30027-STE

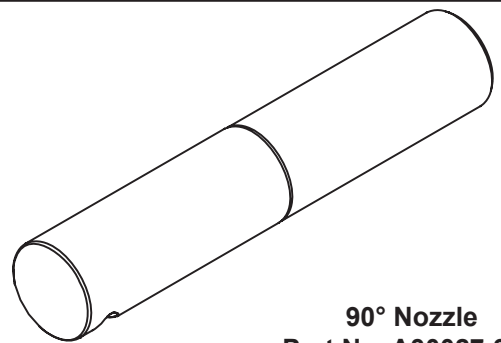

90° Nozzle
Part No. A30027-90E

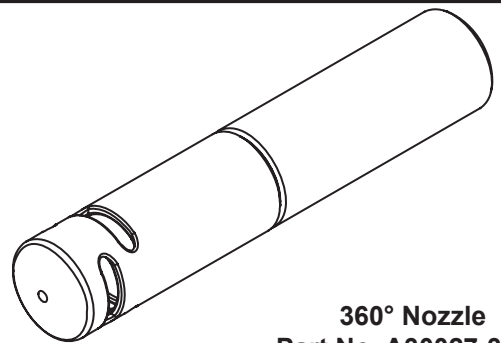

360° Nozzle
Part No. A30027-360E

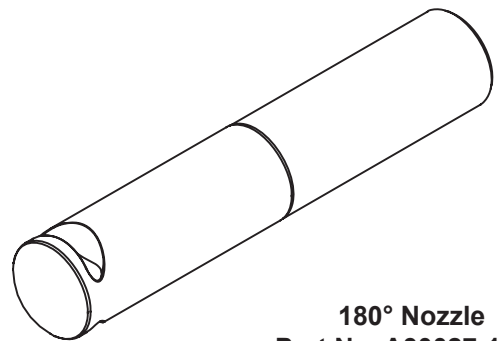

180° Nozzle
Part No. A30027-180E

NOZZLE INSTALLATION INSTRUCTIONS

IMPORTANT

The delivery service is responsible for damage occurring in transit. Martin Engineering CANNOT enter claims for damages. Contact your transportation agent for more information.

1. Inspect shipping container for damage. Report damage to delivery service immediately and fill out delivery service's claim form. Keep any damaged goods subject to examination.
2. Remove air cannon assembly from shipping container. A pressure relief valve, safety restraining cable, and warning labels will be included in this container.
3. If you purchased accessories from Martin Engineering, they will be packaged separately. Remove this equipment from its shipping container.
4. Take inventory of the equipment received. If anything is missing, contact Martin Engineering or representative.

WARNING

Before installing air cannon, lock out/tag out any equipment that is loading or unloading material from the storage vessel.

5. Turn off and lock out/tag out energy source to accessory equipment according to local standards and procedures.

WARNING

If using a cutting torch or welding, test atmosphere for gas level or dust content.

CAUTION

When blasting into closed storage vessel, exhaust vents must be considered to prevent internal storage vessel air pressure from increasing to point where it may damage storage vessel.

6. When blasting into a closed storage vessel, exhaust vents must be considered to prevent internal storage vessel air pressure from increasing to the point where it may damage the storage vessel. Determine the volume of air that will be introduced into the storage vessel with each air cannon blast. Observe local and state codes, which may specify internal pressure limits for your storage vessel.

IMPORTANT

Air cannon force output can vary depending on inlet pressure, discharge opening size, structure size, material in structure, and other factors. To determine maximum force output values for your application, call Martin Engineering.

7. If you need to know air cannon maximum force output for your application, call Martin Engineering.

IMPORTANT

Air cannons operated in extremely dirty and dusty environments must be lubricated to prevent premature wear of air cannon's internal components. Lubricate air cannon with Martin® Air Motor Oil, p/n 14766.

IMPORTANT

Do not mount air cannon at a negative angle, see Figure 1. Dirt and dust can collect in air cannon causing rapid wear of air cannon's internal components.

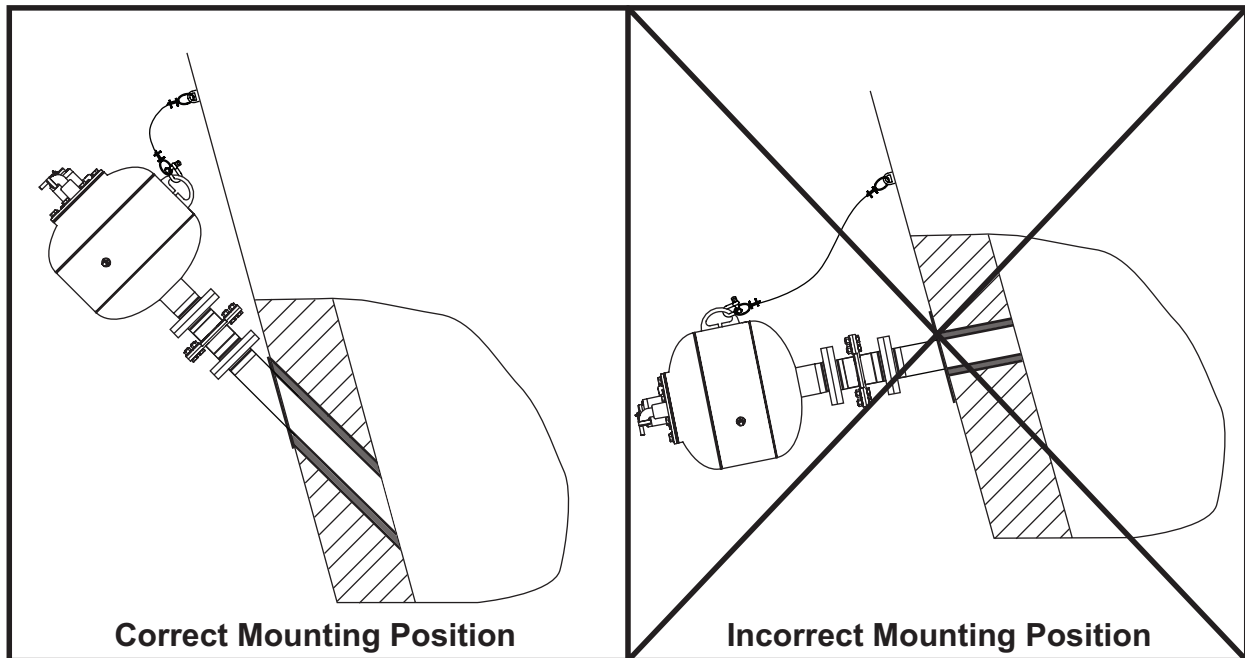

Figure 1. Air Cannon Mounting Orientation

1. To install air cannon, follow the procedures in this section corresponding to the following steps:
 - A. Install mounting plate.
 - B. Connect air cannon to mounting plate.
 - C. Install restraining cable.
 - D. Connect air supply to air cannon. See “electrical solenoid valves” as applicable.
2. A variety of mount plate and nozzle designs are available from Martin Engineering. This section will describe the installation of the most commonly used mount plates and nozzles. The correct mount plate or nozzle must be used for the given application. If you are not sure which mount plate or nozzle to use for your application, contact Martin Engineering or representative.

NOTE

NOTICE OF LIMITED LIABILITY: Due to possible presence of latent structural defects in the apparatus of the purchaser, Martin Engineering shall not be responsible for consequential damage to the purchaser's equipment and/or apparatus resulting from the application of a Martin® Product. Martin Engineering shall not be liable for improper installation by the purchaser or other circumstances beyond the control of Martin Engineering. Liability is disclaimed for the structural soundness of apparatus or equipment not supplied by Martin Engineering. Liability shall be strictly limited to the replacement of the purchased product or refund of the purchase price. To secure the integrity of the installation, specify supervision by qualified personnel from Martin Engineering.

Materials required: Mounting plate or seal plate and support structure.

Notes: High Temp nozzles are SS alloy and must be welded using a welding rod suitable for dissimilar metals.

NOTE

If you are unsure where to locate air cannon(s) on your storage vessel, contact Martin Engineering or your representative.

1. Mark location for each air cannon on storage vessel.
2. A standard carbon steel mount plate or nozzle can be used for internal storage vessel temperatures of less than 500°F (260°C).
3. If using 30-degree mounting plate (Figure 2), cut hole in storage vessel for each mounting plate using templates on last page of this manual. If templates are missing, contact Martin Engineering or representative. Place mounting plate over hole and field weld to storage vessel skin.
4. If mount plate is to be welded to storage vessel, bolt holes must be cut away or plug-welded in order to prevent air leakage upon discharge. If mount plate is to be bolted to storage vessel, gasket must be used to prevent air leakage upon discharge.
5. If storage vessel has a liner (Figure 3), drop-through blow-pipe must be used. The blow pipe must be extended past liner so that liner is not damaged from air cannon blast.
6. Martin® Smart™ Series Nozzles and blow pipes should be used in applications where the internal storage vessel temperature exceeds 500°F (260°C).

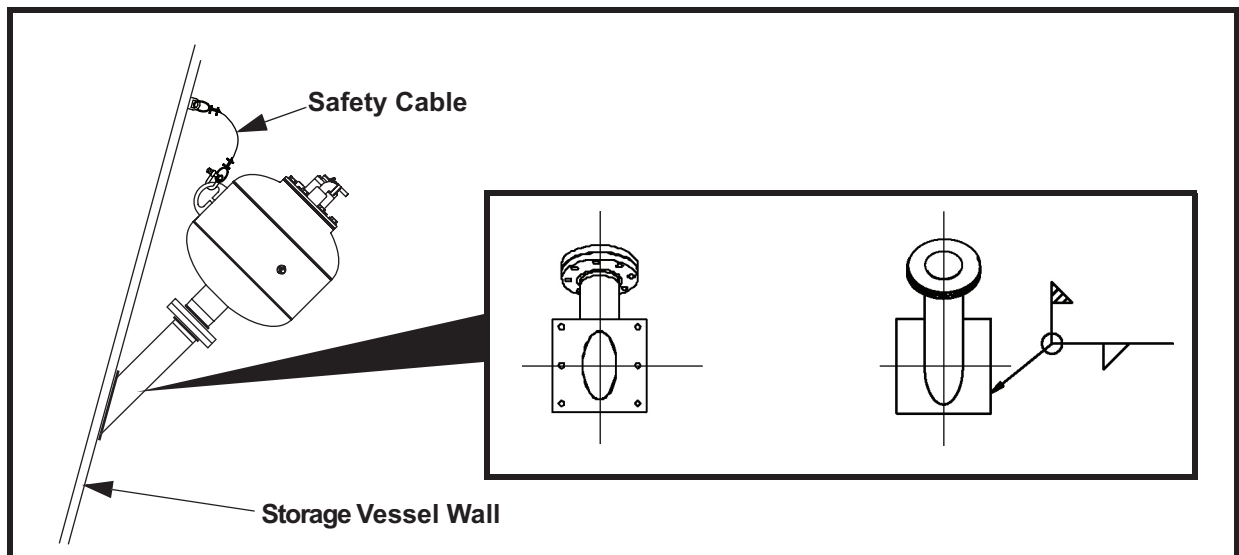

Figure 2. Installing 30-Degree Mounting Plate

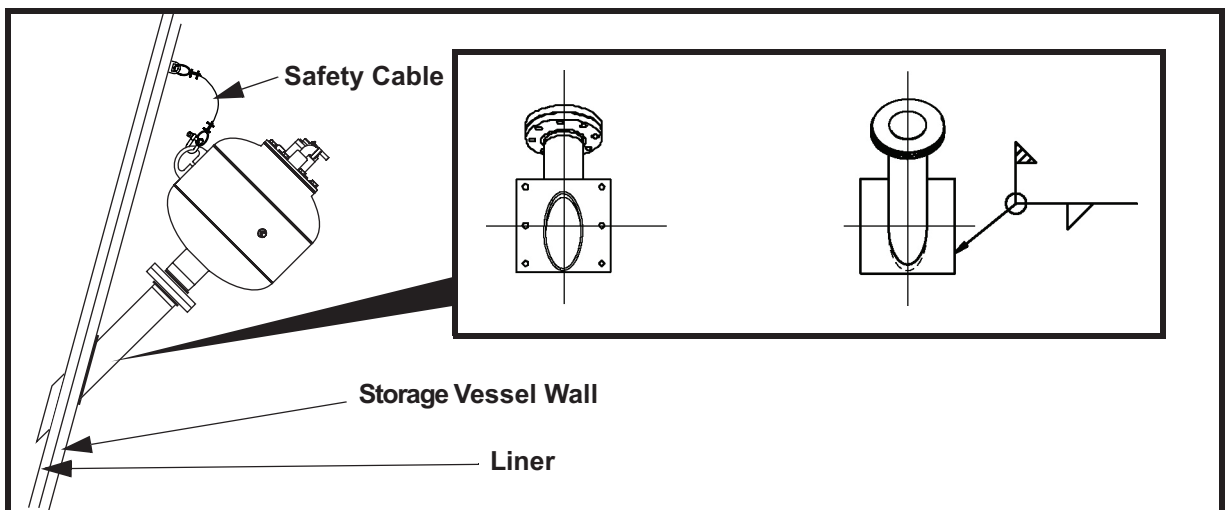

Figure 3. Installing a Drop-Through 30-Degree Mounting Plate for Storage Vessels with Liner

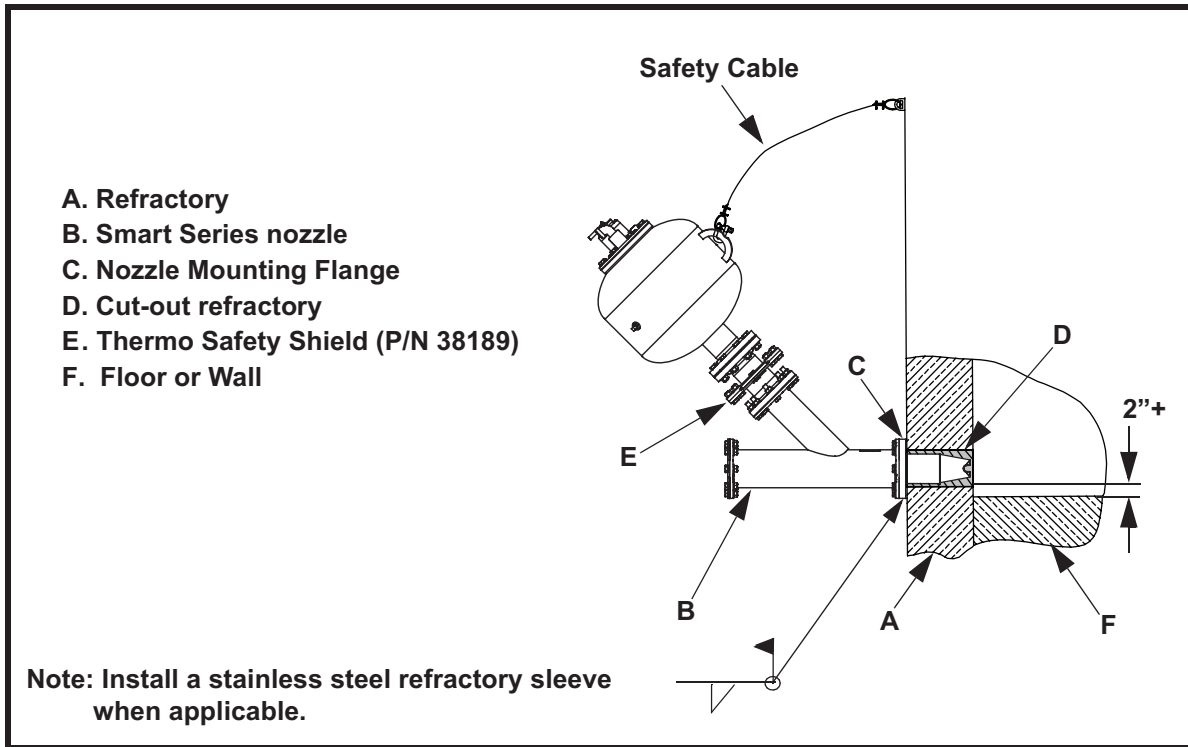

Figure 4. Installing Martin® Smart™ Series Jet Nozzle for High-Temperature Applications

1. Plan view of nozzle placement for riser duct application. Alternate levels between Pattern 1 and Pattern 2 for maximum area coverage.

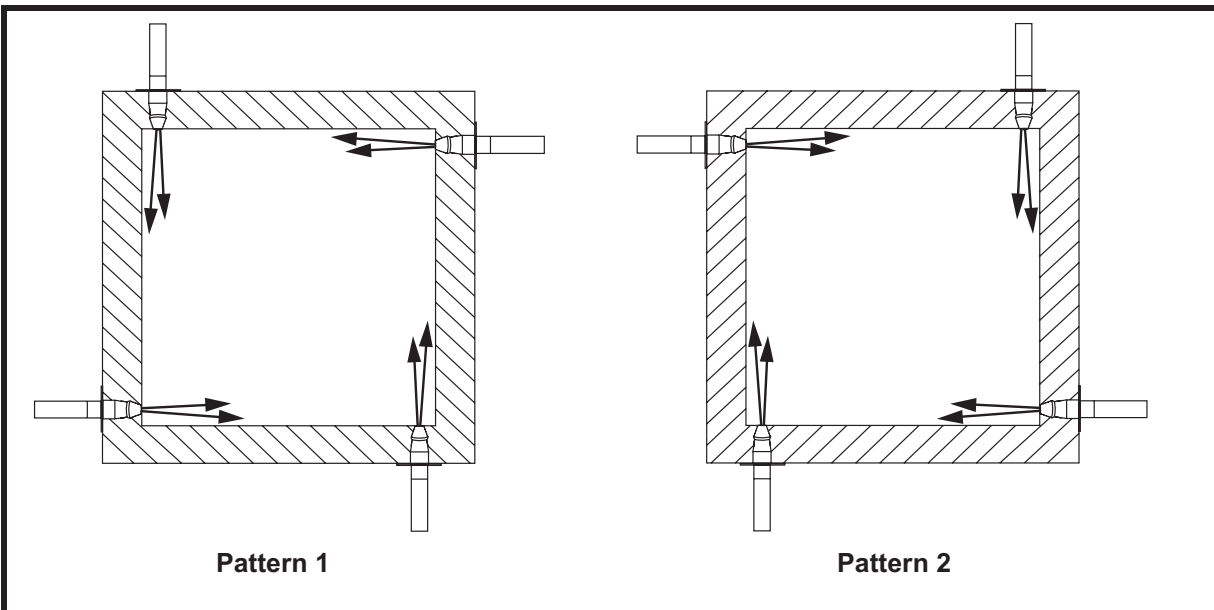

Figure 5. Riser Duct with Fan Nozzles for High-Temperature Applications

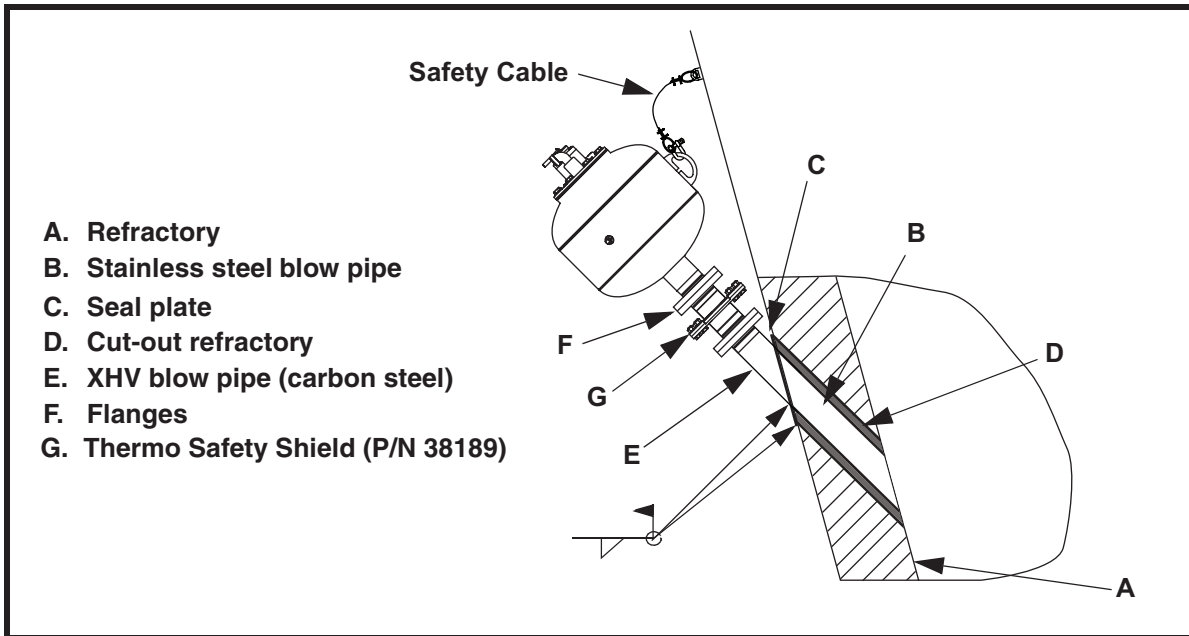

Figure 6. Installing Stainless Steel Blow Pipe and Carbon Steel Blow Pipe for High-Temperature Applications

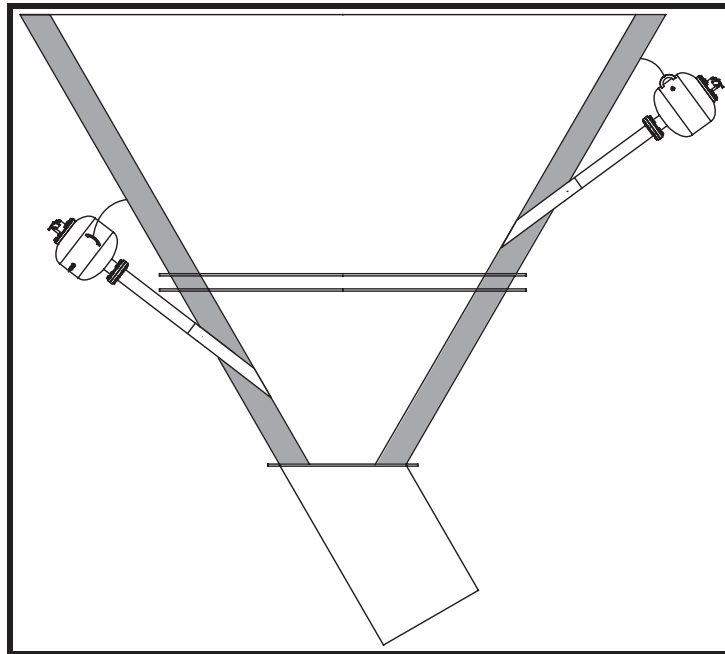

Figure 7. Cyclone with High-Temperature Blow Pipes

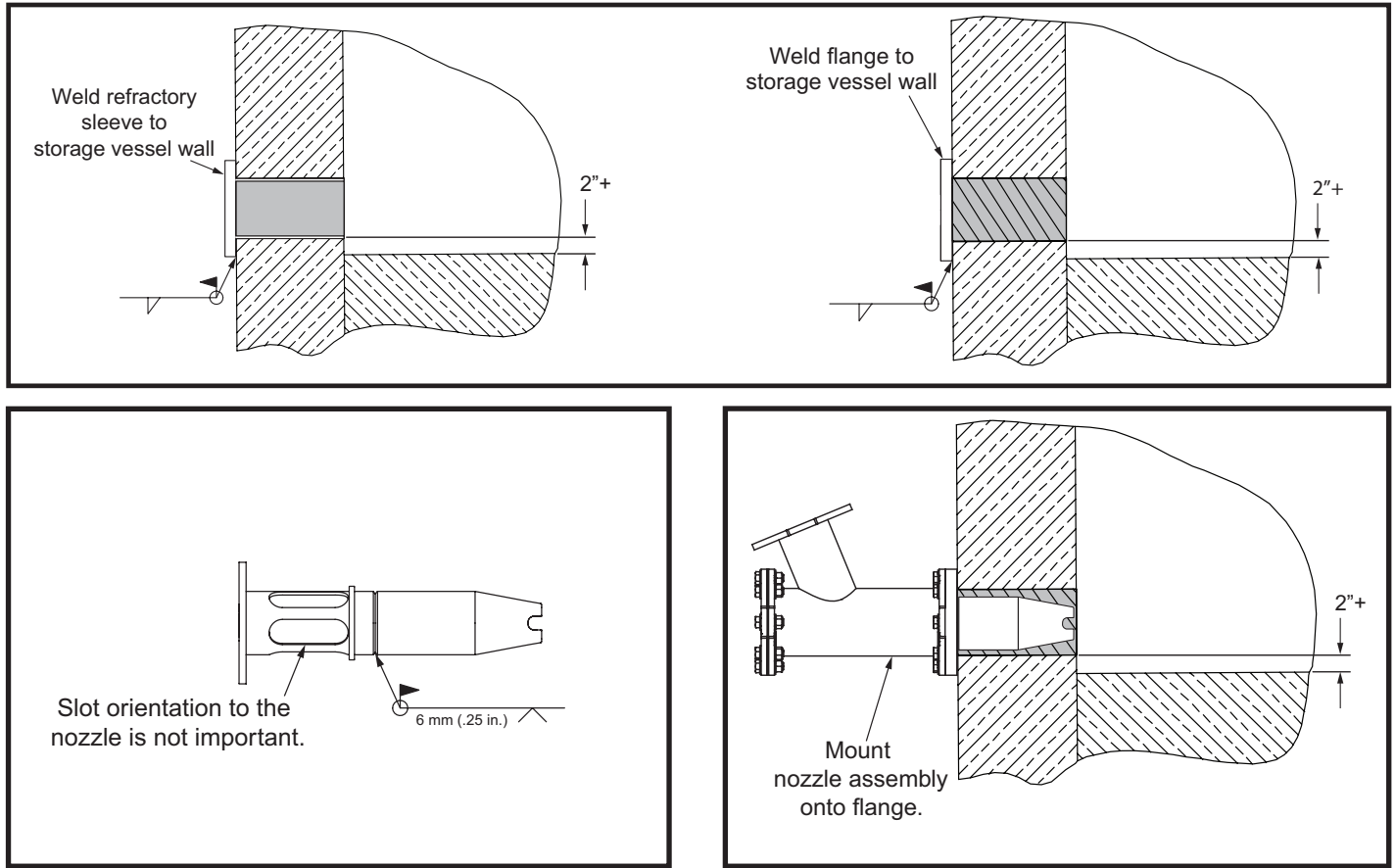

Figure 8. Martin® Smart™ Series Nozzle Installation

When refractory is present:

1. Cut a 6 inch (150 mm) hole in storage vessel wall.
2. Core drill a 5 inch (127 mm) hole through refractory.
3. Weld/install mounting flange.

When no refractory is present:

4. Cut hole in storage vessel wall to accommodate SS sleeve.
5. Insert SS sleeve into hole.
6. Weld/install mounting flange.

IMPORTANT

Field Fit Nozzles allow for the complete assembly to meet the depth of refractory in that area. This nozzle can have pipe added or removed so that the tip of the nozzle is even with the front face of the refractory.

7. Cut nozzle to desired length.
8. Weld nozzle tip to nozzle pipe. Use 319L welding wire for dissimilar metals.
9. Mount nozzle assembly onto flange.



Martin Engineering USA
 One Martin Place
 Neponset, IL 61345-9766 USA
 800 544 2947 or 309 852 2384
 Fax 800 814 1553
 www.martin-eng.com

Martin Engineering Company India Pvt. Ltd.
 Plot 191, 192, 193, Vadu Khurd Alandi-Markal
 Road, Phulgaon Pune 412216, India
 Ph.: +91 20 66788270
 salesindia@martin-eng.com | www.martin-eng.in

**COMPANY WITH
 QUALITY SYSTEM
 CERTIFIED BY DNV GL
 = ISO 9001 =**