

martin®

Martin® ***INDOCLEAN***
Secondary Assembly



Operator's Manual

Important

MARTIN ENGINEERING HEREBY DISCLAIMS ANY LIABILITY FOR: DAMAGE DUE TO CONTAMINATION OF THE MATERIAL; USER'S FAILURE TO INSPECT, MAINTAIN AND TAKE REASONABLE CARE OF THE EQUIPMENT; INJURIES OR DAMAGE RESULTING FROM USE OR APPLICATION OF THIS PRODUCT CONTRARY TO INSTRUCTIONS AND SPECIFICATIONS CONTAINED HEREIN. MARTIN ENGINEERING'S LIABILITY SHALL BE LIMITED TO REPAIR OR REPLACEMENT OF EQUIPMENT SHOWN TO BE DEFECTIVE.

Observe all safety rules given herein along with owner and Government standards and regulations. Know and understand lockout/tagout procedures as defined by American National Standards Institute (ANSI) z244.1-1982, *American National Standard for Personnel Protection - Lockout/Tagout of Energy Sources - Minimum Safety Requirements* and Occupational Safety and Health Administration (OSHA) Federal Register, Part IV, 29 CFR Part 1910, *Control of Hazardous Energy Source (Lockout/Tagout); Final Rule*.

The following symbols may be used in this manual:



Danger: Immediate hazards that will result in severe personal injury or death.



Warning: Hazards or unsafe practices that could result in personal injury.



Caution: Hazards or unsafe practices that could result in product or property damages.



Important: Instructions that must be followed to ensure proper installation/operation of equipment.



Note: General statements to assist the reader.

Introduction

General

To introduce product back into the product flow, a Pre-Cleaner is installed on the face of the head pulley. On a dual cleaner system, the Secondary Cleaner is installed immediately following the Pre-Cleaner to remove stubborn material left on the conveyor belt. If a Pre-Cleaner cannot be used because of space limitations, the Secondary Cleaner is installed alone. If the material-handling process or product could be affected by contamination from the use of these belt cleaners, the user is responsible for taking the necessary steps to prevent contamination. Consult Martin Engineering or a representative for alternate belt cleaners or belt cleaner locations to use where contamination may be an issue.

Installations without chutework

These procedures were written for equipment that is being installed on enclosed pulley chutework. If the pulley is not enclosed, the equipment should be installed using the best available field resources and methods to ensure that the critical dimensions are followed for proper installation.

Materials required

Installation of this equipment requires the use of standard hand tools, grinder, welder, and cutting torch.

Safety

All safety rules defined in the above documents and all owner/employer safety rules must be strictly followed when working on the belt cleaner.



⚠ DANGER

Do not touch or go near the conveyor belt or conveyor accessories when the belt is running. Your body or clothing can get caught and you can be pulled into the conveyor, resulting in severe injury or death.



⚠ DANGER

Before installing, servicing, or adjusting the belt cleaner, turn off and lock out/tag out all energy sources to the conveyor and conveyor accessories according to ANSI standards. Failure to do so could result in serious injury or death.



⚠ DANGER

If this equipment will be installed in an enclosed area, test the gas level or dust content before using a cutting torch or welding. Using a torch or welding in an area with gas or dust may cause an explosion resulting in serious injury or death.



⚠ WARNING

Before using a cutting torch or welding the chute wall, cover the conveyor belt with a fire retardant cover. Failure to do so can allow the belt to catch fire.

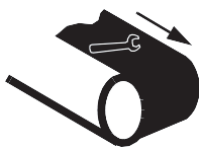

⚠ WARNING

Remove all tools from the installation area and conveyor belt before turning on the conveyor. Failure to do so can cause serious injury to personnel or damage to the belt and conveyor.



⚠ WARNING

Mainframe with blade can be heavy and may require two people to lift. Attempting to lift the belt cleaner without assistance could result in injury.

Before Installing Belt Cleaner

IMPORTANT

The delivery service is responsible for damage occurring in transit. Martin Engineering CANNOT enter claims for damages. Contact your transportation agent for more information.

1. Inspect shipping container for damage. Report damage to delivery service immediately and fill out delivery service's claim form. Keep any damaged goods subject to examination.
2. Remove belt cleaner assembly from shipping container.
3. If anything is missing contact Martin Engineering or a representative.



WARNING

Before installing equipment, turn off and lock out/ tag out all energy sources to the conveyor and conveyor accessories according to ANSI standards. Failure to do so could result in serious injury or death.

4. Turn off and lock out/tag out energy source according to ANSI standards (see "References").

DANGER

If this equipment will be installed in an enclosed area, test the gas level or dust content before using a cutting torch or welding. Using a torch or welding in an area with gas or dust may cause an explosion resulting in serious injury or death.

5. If using a cutting torch or welding, test atmosphere for gas level or dust content. Cover conveyor belt with fire retardant cover.



IMPORTANT

Center the belt cleaner blades to clean an area narrower than the conveyor belt width. This allows for side-to-side movement of the belt and prevents damage to the belt edge.

Installing Belt Cleaner Assembly

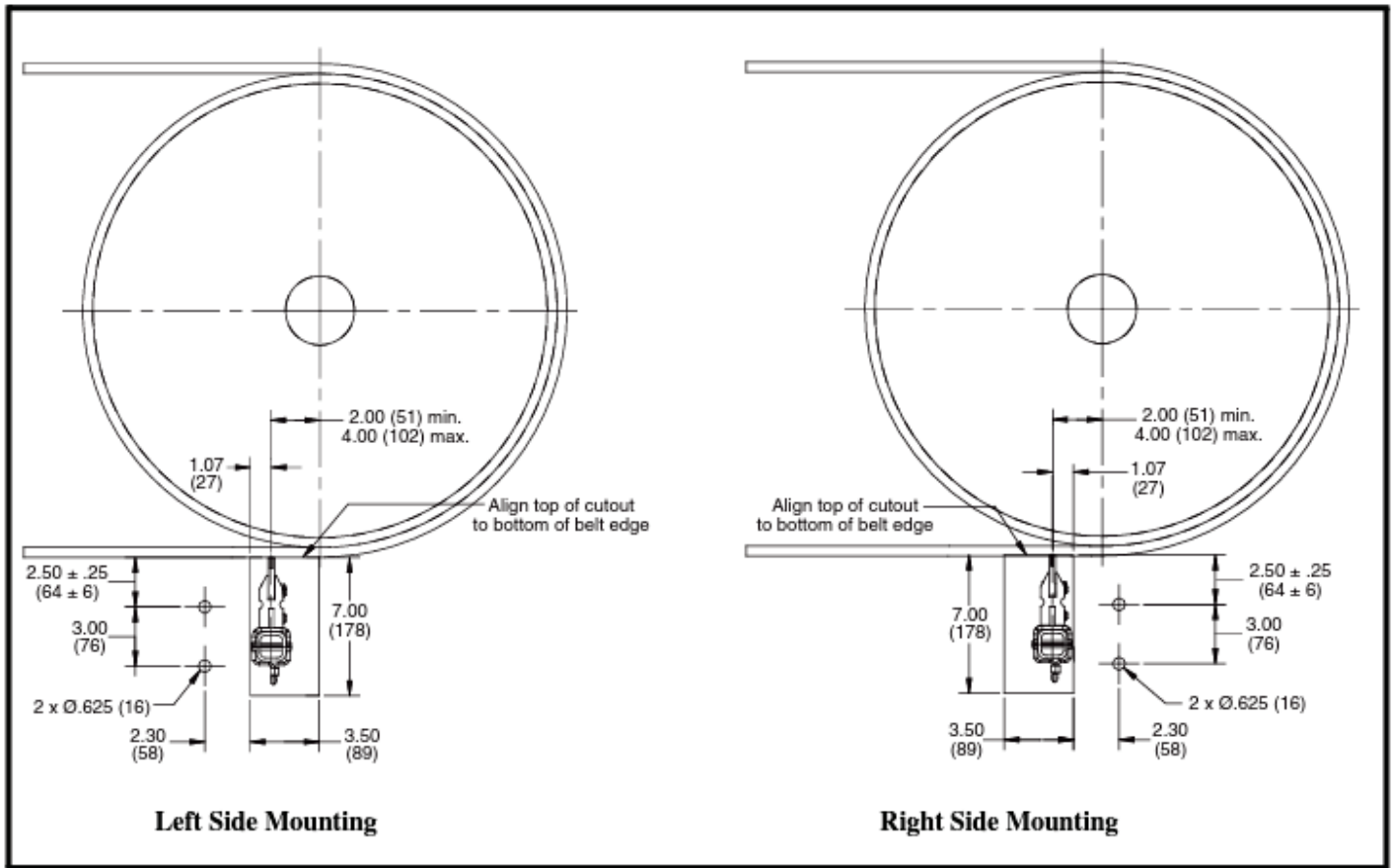

Figure 1. Mounting Locations

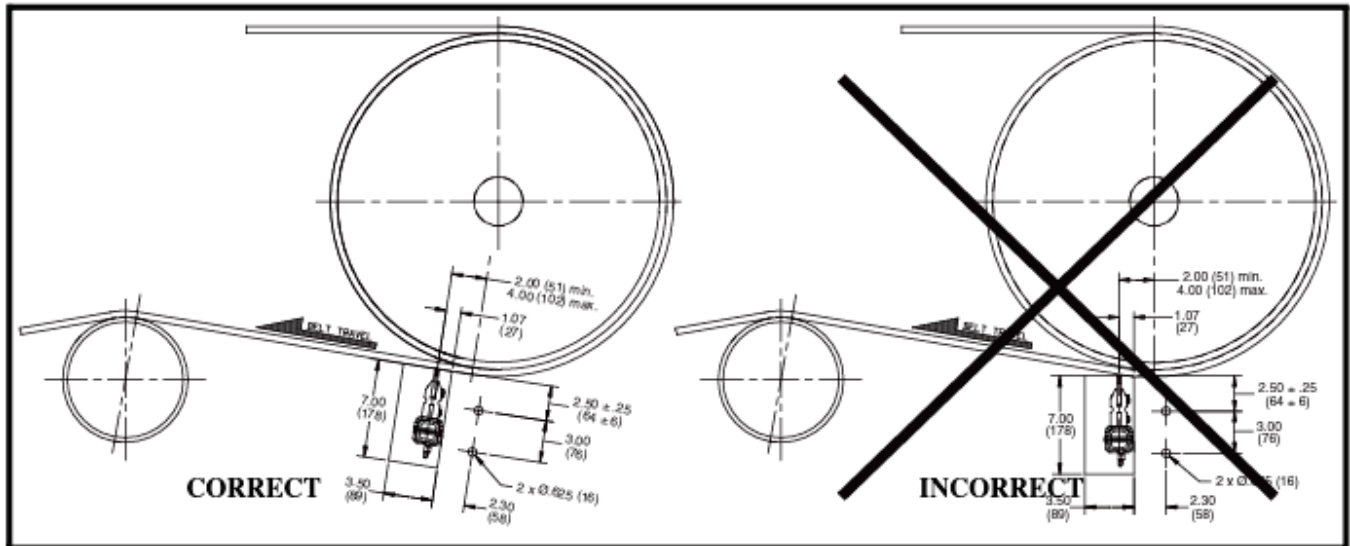

Figure 2. Tangent Point

IMPORTANT

Belt cleaner mounting location must be marked using a line perpendicular to the belt line at the tangent point (point where the belt leaves the head pulley), see Figure 2. **DO NOT** use the vertical centerline of the head pulley.

NOTE

Solid backing of the blade is essential to ensure proper operation and efficient cleaning. Install the cleaner adjacent to the head pulley or a flat pressure roller to obtain best cleaning results.

NOTE

For installation on enclosed head pulley chutework, draw all dimension lines on chute wall. In applications where head pulley is not enclosed, use the best available field resources and/or methods to ensure that these critical dimensions are followed for a proper installation.

Marking chute cutouts

1. Mark the chute cutout and mount hole locations as shown in Figure 1. Repeat on both sides of chute, ensuring cutouts are accurately aligned with each other.
2. At the selected mounting position, cut the cleaner access slots and drill the mount holes in each side of the chute. Dress and de-burr the holes and cutouts.

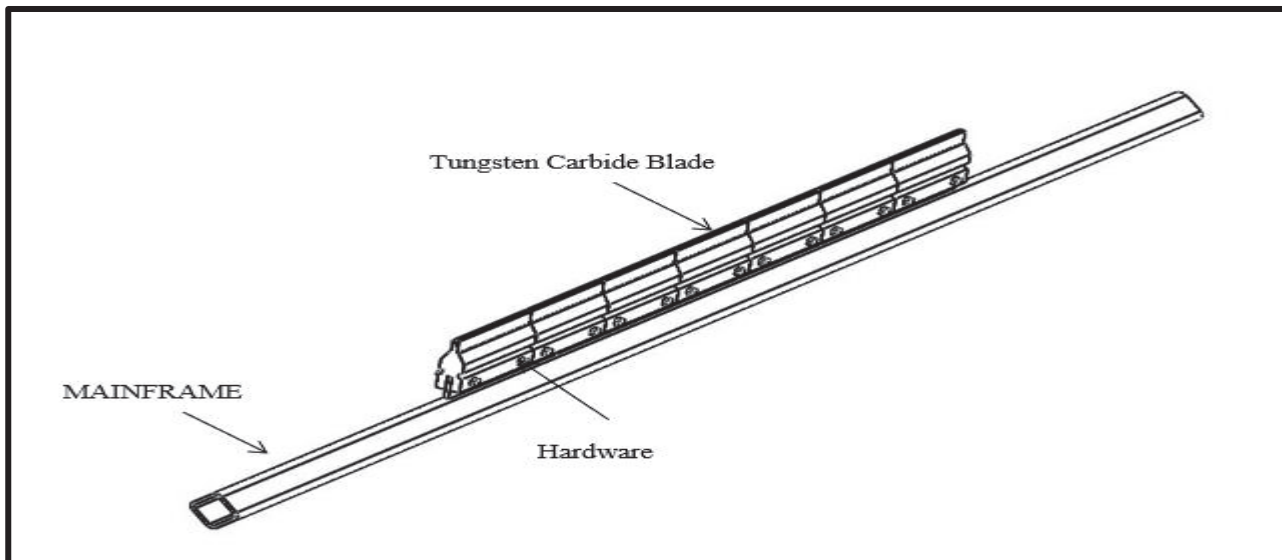

Figure 3. Removing and Installing Blade Cartridge

Removing blade

1. Remove fastener from mainframe and blade.
2. Pull blade away from mainframe.

Installing blade

1. Slide blade onto mainframe with blade positioned as shown in Figure 1. Push far side end of blade against stationary pin until it locks.
2. Insert lock pin in mainframe and cartridge.
3. Make sure blades are centered on belt and mainframe is parallel to belt.
4. Tension belt cleaner according to *Martin® SQC2S™ Square Mainframe Tensioner Operator's Manual*, P/N M3815.

After Installing Belt Cleaner



1. Thoroughly wipe chute wall clean above tensioner.
2. Place Conveyor Products Warning Label (P/N 23395) on outside chute wall visible to belt cleaner operator.

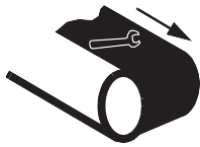

⚠ WARNING

Failure to remove tools from installation area and conveyor belt before turning on energy source can cause serious injury to personnel and damage to belt.



⚠ DANGER

Do not touch or go near conveyor belt or conveyor accessories when conveyor belt is running. Body or clothing can get caught and pull body into conveyor belt, causing severe injury or death.

3. Turn on conveyor belt for 1 hour, then turn off.



⚠ DANGER

Before installing, servicing, or adjusting the belt cleaner/tensioner, turn off and lock out/tag out all energy sources to the conveyor and conveyor accessories according to ANSI standards. Failure to do so could result in serious injury or death.

4. Make sure all fasteners are tight. Tighten if necessary.
5. Make sure cleaner is not changing belt line. If it is, install belt support ahead of blade-to-belt contact point (Secondary Cleaner).
6. Inspect belt cleaner for the following:
 - Wear. (A small amount of “break-in” wear may be found. This will stop once blades wear to conveyor belt contour.)
 - Material buildup. (No material between blades and return side of conveyor belt should be found.)
7. If wear, material buildup, or some other problem exists, see “Troubleshooting.”

IMPORTANT

Read entire section before beginning work.

NOTE

Maintenance inspection should be performed no less than weekly. Some applications may require more frequent maintenance inspections.



⚠ DANGER

Before installing, servicing, or adjusting the belt cleaner/tensioner, turn off and lock out/tag out all energy sources to the conveyor and conveyor accessories according to ANSI standards. Failure to do so could result in serious injury or death.

1. Remove any material from belt cleaner.
2. Make sure all fasteners are tight. Tighten if necessary.
3. Check tension on cleaner. Re-tension if necessary.
4. Wipe all labels clean. If labels are not readable, contact Martin Engineering or a representative for replacements.
5. Check blades for excessive wear. Replace if necessary.
6. Remove equipment from service if there is any indication it is not functioning properly. Call Martin Engineering or a representative for assistance. Do NOT return equipment to operation until the cause of the problem has been identified and corrected.

⚠ WARNING

Failure to remove tools from installation area and conveyor belt before turning on energy source can cause serious injury to personnel and damage to belt.

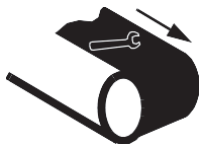

7. Remove all tools from maintenance area.

⚠ DANGER

Do not touch or go near conveyor belt or conveyor accessories when conveyor belt is running. Body or clothing can get caught and pull body into conveyor belt, causing severe injury or death.



8. Start conveyor belt.

Troubleshooting

Symptom	Corrective Action
Insufficient cleaning and carryback.	<ul style="list-style-type: none"> • Tension of cleaner on belt is set too low or too high. Increase or decrease tensioner setting. • Blades are worn. Check blades and replace if necessary.
Noise or vibration.	Tension is not sufficient or is set too high. Correct tension as necessary. If this does not correct problem, blade urethane may not match application. Contact Martin Engineering or representative.
High blade wear rate.	Tension of cleaner on belt is set too high. Reduce tensioner setting.
Unusual wear or damage to blades.	Check belt splice(s) and repair as necessary.
Bent or broken mainframe or support frame due to blade slipping through.	If blades are worn to or past the wear line, replace blades. If blades are not worn, check mainframe location.
Corrosion or chemical degradation.	Blade urethane may not match application. Contact Martin Engineering or representative.

NOTE

Conveyor equipment such as conveyor belt cleaners are subject to a wide variety of bulk materials characteristics and often have to perform under extreme operating or environmental conditions. It is not possible to predict all circumstances that may require troubleshooting. Contact Martin Engineering or a representative if you are experiencing problems other than those listed in the “Troubleshooting” chart above. Do not return the equipment to operation until the problem has been identified and corrected.

Installation checklist

If after taking the corrective actions suggested under “Troubleshooting” you are still experiencing problems, check for the following:

Installation Checklist
Pre-Cleaner mainframe is proper distance from belt surface on both ends of mainframe.
Pre-Cleaner blade tip is at or below horizontal center line of pulley and does not lie in path of material flow.
Secondary Cleaner blade tip is 2 in. (51 mm) past vertical center line of pulley.
Secondary Cleaner is not changing belt line.
Blades are centered on belt.

Problem Solved™
GUARANTEED!

Martin Engineering INDIA



Plot 191, 192, 193, Vadu Khurd
Alandi-Markal Road, Phulgaon
Pune 412216, India ,

+91 20 66788270

<https://www.martin-eng.in/>