

## PRIMARY CLEANER

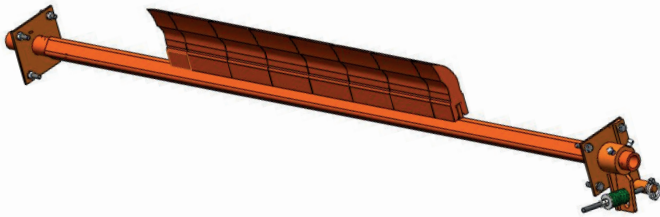

The **Martin® IndoClean Primary Cleaner** is a new evolution in belt cleaner technology designed to help your operation achieve a higher level of productivity while simultaneously reducing costs! It is guaranteed to provide you with the highest performance and the lowest cost of ownership of any urethane precleaner.

### FEATURES & BENEFITS

- Manufactured with Martin's unique Constant Angle Radial Pressure (CARP) technology, its curved blade simply cleans the belt better, minimizing carryback.
- Martin re-engineered the manufacturing process, streamlining it to be faster and more efficient, which means your cost to purchase is lower.
- The overall cost of maintenance is much less because the blades last longer
- Segmented PU blades arrangement is easy to stock, service and maintenance
- Engineered tensioner to ensure optimum blade life.

## SECONDARY CLEANER

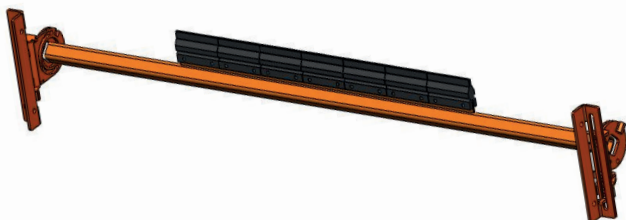

The **Martin® IndoClean Secondary Cleaner** incorporates individually-cushioned tungsten carbide blades for effective cleaning without risk to belt, splice or blade. Installed in the secondary cleaner position, the Martin® IndoClean secondary blade buffers cushion impact and maintains cleaning pressure.

### FEATURES & BENEFITS

- Rugged belt cleaner construction withstands punishing applications
- Rubber buffers maintain cleaning pressure while deflecting to allow splices to pass.
- Compact secondary belt cleaner design allows installation in close quarters; narrow profile resists material buildup.
- Rubber buffers allow for reversal of belt direction without damage to belt.

### SPECIFICATIONS

Belt Width	Belt Speed	Pulley Diameter
up to 2000 mm	up to 3.5 m/s	up to 650mm

For other application specifications, please consult with Martin representative.

## DIMENSIONS

Belt Width (mm)	IndoClean Primary P/N	IndoClean Secondary P/N	Blade Width (mm)	Mainframe Length (mm)
18"(450)	BINC1ICP1812O2TS	BINC2ICS1812MRPT	300	1500
24"(600)	BINC1ICP2418O2TS	BINC2ICS2418MRPT	450	1650
30"(750)	BINC1ICP3024O2TS	BINC2ICS3024MRPT	600	1800
36"(800)	BINC1ICP3630O2TS	BINC2ICS3630MRPT	750	1950
42"(1000)	BINC1ICP4236O2TS	BINC2ICS4236MRPT	900	2100
48"(1200)	BINC1ICP4842O2TS	BINC2ICS4842MRPT	1050	2250
54"(1400)	BINC1ICP5448O2TS	BINC2ICS5448MRPT	1200	2400
60"(1600)	BINC1ICP6054O2TS	BINC2ICS6054MRPT	1350	2750
72"(1800)	BINC1ICP7266O2TS	BINC2ICS7266MRPT	1650	3050
78"(2000)	BINC1ICP7872O2TS	BINC2ICS7872MRPT	1800	3200

Note: Dual Tensioners are required for belt widths (1200 mm) and greater.

## MOUNTING LOCATION

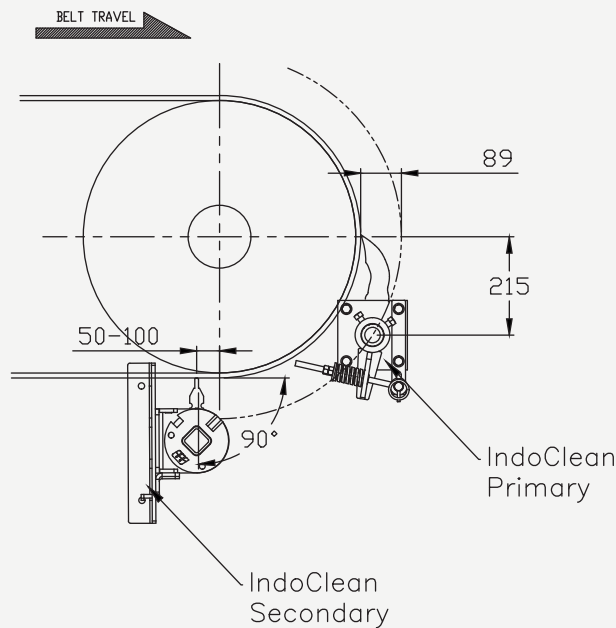

## MARTIN® HIGH-PERFORMANCE URETHANES

Urethane Color	Application Description	Temperature Range
	Orange Standard Martin®Urethane is suitable for most belt cleaner applications, including <b>abrasive conditions</b>	Up to 70°C

For higher temperature application, please consult with Martin representative.

**Martin Engineering Company India Pvt. Ltd.**

Plot 191, 192, 193, Vadu Khurd, Alandi-Markal Road,  
Phulgaon, Pune 412216, India

Tel- 020-66788270

Email [salesindia@martin-eng.com](mailto:salesindia@martin-eng.com)

[www.martin-eng.in](http://www.martin-eng.in)