

Martin® Idler Conversion Kit



Eliminate Sag, Spillage, and Material Entrapment
 Improve Belt Support with Martin® Slider Bars.

The [Martin® Idler Conversion Kit](#) improves a conveyor's belt support system, stabilizing the line, improving sealing, and preventing spillage. This simple kit links two more troughing idler frames, replacing the wing rollers with Martin® Slider Bars.

BENEFITS

- **Stable Belt Line Improves Sealing**
 No more sag, no more spillage. Edge sealing systems work more effectively on stable belt line.
- **Prevents Entrapment Damage**
 Without sag, there's no risk of material becoming wedged in pinch point to gouge belt.
- **Economical Conveyor Upgrade**
 Reuse existing idler frames and center rollers for a cost-conscious system improvement.
- **Reduces Maintenance**
 No adjustment necessary; no lubrication required.
- **Low Friction Surface**
 Improve belt support without increasing drive power requirements.
- **Flexible Placement**
 Custom-length bars improve belt support points where conveyor needs it most, including tight spaces.
- **Simple to Install**
 Replace wing rollers easily; kit conforms to wide range of idler manufacturers.

PROBLEMS

Belt sag between idlers allows spillage, creating maintenance problems, cleanup costs, and regulatory issues.

Entrapped material gouges belt cover, shortening belt life.

SOLUTION

Stable sag-free belt line allows improved sealing for reduced spillage and reduced maintenance problems.

No bearings to seize; no lubrication required.

NOTES

Martin® Slider Cradles are designed to work with CEMA B, C and D belts with a maximum notch in the frame of 1.06 in.

Double Bar Conversion Kits are recommended for applications where conveyor capacity is more than 450 tons (408 metric tons) per hour, or where the wing rolls are longer than 13 inches (330 mm), as typically seen on belts over 36 inches (900 mm) wide.

Wing Roll must be a minimum of 14 1/2 in. to hold two bars.

To add an additional bar to belt widths less than 8" order P/N 37613. P/N 37613 contains 1 clamp assembly. Need 2-37613 per bar.

When installing more than four feet (1.2 m) of Martin® Slider Cradles, it is necessary to check for adequate power in the conveyor drive to overcome the additional friction against the belt. Contact Martin Engineering for additional information.

Martin® Slider Cradles are not recommended for conveyors operating at speed over 700 fpm (3.5 m/sec) or conveyors less than 50 ft (15 m) in length.

To improve belt support on short conveyors or high-speed belts, contact Martin Engineering.

TECHNICAL DATA SHEET

CONVERSION KIT

Select by belt width

Belt Width in. (mm)	P/N	Each Kit Includes
24 (610)	37135-K24	Two Idler Conversion Brackets (enough for one idler set).
30 (762)	37135-K30	
36 (914)	37135-K36	
42 (1067)	37135-K42	
48 (1219)	37135-K48	Two or four Conversion Clamps (to hold support bars to Conversion Brackets. Quantity depends on whether belt width requires one or two bars per side of cradle).
54 (1372)	37135-K54	
60 (1524)	37135-K60	
66 (1676)	37135-K66	Two Bars per side start at 48" belt width.
72 (1829)	37135-K72	
84 (2134)	37135-K84	
96 (2438)	37135-K96	

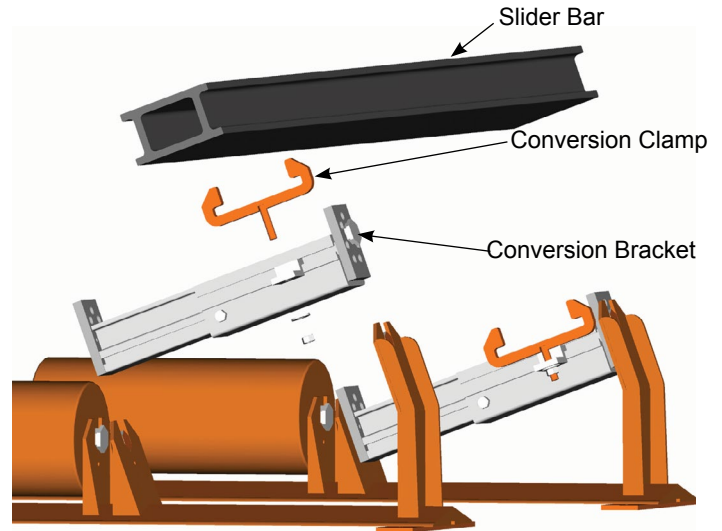

SLIDER BAR

Select by length of bar required

Bar Length ft. (mm)	P/N
3 (914)	37135-B36
4 (1219)	37135-B48
5 (1424)	37135-B60
6 (1829)	37135-B72
7 (2134)	37135-B84
8 (2438)	37135-B96
9 (2743)	37135-B208
10 (3048)	37135-B120
11 (3353)	37135-B132
12 (3568)	37135-B144

TO ORDER:

Measure distance supported and count the idlers to be converted.

Example		Correct Order	
Belt Width	30 in. (762 mm)	Conversions Kit: P/N 37135-K30	Quantity: 8
Distance to be Converted (Ea. Side)	32 ft. (9.75 m)	Support Bars: P/N 37135-B96	Quantity: 8
Number of Idlers to convert:	8		

Each P/N is one bar; order enough bars for both sides of each cradle. Note if cradles need one bar or two bars per side.



Martin Engineering USA

One Martin Place
Neponset, IL 61345-9766 USA
800 544 2947 or 309 852 2384
Fax 800 814 1553
www.martin-eng.com

**COMPANY WITH
QUALITY SYSTEM
CERTIFIED BY DNV
= ISO 9001:2008 =**

Problem Solved™ GUARANTEED!

Form No. L3614-09/15
© Martin Engineering Company 2002, 2015