

PART NUMBER	BELT WIDTH	DIM "A"	DIM "B"	NO. OF BLADES
C1HH1XS1801XXXX	457.2 [18.00]	1676.4 [66.000]	200.0 [7.87]	1
C1HH1XS1802XXXX	457.2 [18.00]	1676.4 [66.000]	400.0 [7.87]	2
C1HH1XS2402XXXX	609.6 [24.00]	1828.8 [72.00]	400.0 [7.87]	2
C1HH1XS2403XXXX	609.6 [24.00]	1828.8 [72.00]	600.0 [23.62]	3
C1HH1XS3003XXXX	762.0 [30.00]	1981.2 [78.00]	600.0 [23.62]	3
C1HH1XS3004XXXX	762.0 [30.00]	1981.2 [78.00]	800.0 [31.50]	4
C1HH1XS3603XXXX	914.4 [36.00]	2133.6 [84.00]	600.0 [23.62]	3
C1HH1XS3604XXXX	914.4 [36.00]	2133.6 [84.00]	800.0 [31.50]	4
C1HH1XS4204XXXX	1066.8 [42.00]	2286.0 [90.00]	800.0 [31.50]	4
C1HH1XS4205XXXX	1066.8 [42.00]	2286.0 [90.00]	1000.0 [39.37]	5
C1HH1XS4805XXXX	1219.2 [48.00]	2438.4 [96.00]	1000.0 [39.37]	5
C1HH1XS4806XXXX	1219.2 [48.00]	2438.4 [96.00]	1200.0 [47.24]	6
C1HH1XS5405XXXX	1371.6 [54.00]	2590.8 [102.00]	1000.0 [39.37]	5
C1HH1XS5406XXXX	1371.6 [54.00]	2590.8 [102.00]	1200.0 [47.24]	6
C1HH1XS6006XXXX	1524.0 [60.00]	2743.2 [108.00]	1200.0 [47.24]	6
C1HH1XS6007XXXX	1524.0 [60.00]	2743.2 [108.00]	1400.0 [55.12]	7
C1HH1XS6607XXXX	1676.4 [66.00]	2895.6 [114.00]	1400.0 [55.12]	7
C1HH1XS6608XXXX	1676.4 [66.00]	2895.6 [114.00]	1600.0 [63.00]	8
C1HH1XS7208XXXX	1828.8 [72.00]	3048.0 [120.00]	1600.0 [63.00]	8
C1HH1XS7209XXXX	1828.8 [72.00]	3048.0 [120.00]	1800.0 [70.89]	9
C1HH1XS7809XXXX	1981.2 [78.00]	3200.4 [126.00]	1800.0 [70.89]	9
C1HH1XS7810XXXX	1981.2 [78.00]	3200.4 [126.00]	2000.0 [78.74]	10
C1HH1XS8409XXXX	2133.6 [84.00]	3352.8 [132.00]	1800.0 [70.89]	9
C1HH1XS8410XXXX	2133.6 [84.00]	3352.8 [132.00]	2000.0 [78.74]	10
C1HH1XS9010XXXX	2286.0 [90.00]	3505.2 [138.00]	2000.0 [78.74]	10
C1HH1XS9011XXXX	2286.0 [90.00]	3505.2 [138.00]	2200.0 [86.61]	11
C1HH1XS9611XXXX	2438.4 [96.00]	3657.6 [144.00]	2200.0 [86.61]	11
C1HH1XS9612XXXX	2438.4 [96.00]	3657.6 [144.00]	2400.0 [94.49]	12
C1HH1XA212XXXX	2590.8 [102.00]	3810.0 [150.00]	2400.0 [94.49]	12
C1HH1XA213XXXX	2590.8 [102.00]	3810.0 [150.00]	2600.0 [102.36]	13

EXTENDED MAINFRAME CHART	
PART NUMBER	DIM "A"
C1HH1XS1801XXEX	1981.2 [78.00]
C1HH1XS1802XXEX	1981.2 [78.00]
C1HH1XS2402XXEX	2133.6 [84.00]
C1HH1XS2403XXEX	2133.6 [84.00]
C1HH1XS3003XXEX	2286.0 [90.00]
C1HH1XS3004XXEX	2286.0 [90.00]
C1HH1XS3603XXEX	2438.4 [96.00]
C1HH1XS3604XXEX	2438.4 [96.00]
C1HH1XS4204XXEX	2590.8 [102.00]
C1HH1XS4205XXEX	2590.8 [102.00]
C1HH1XS4805XXEX	2743.2 [108.00]
C1HH1XS4806XXEX	2743.2 [108.00]
C1HH1XS5405XXEX	2895.6 [114.00]
C1HH1XS5406XXEX	2895.6 [114.00]
C1HH1XS6006XXEX	3048.0 [120.00]
C1HH1XS6007XXEX	3048.0 [120.00]
C1HH1XS6607XXEX	3200.4 [126.00]
C1HH1XS6608XXEX	3200.4 [126.00]
C1HH1XS7208XXEX	3352.8 [132.00]
C1HH1XS7209XXEX	3352.8 [132.00]
C1HH1XS7808XXEX	3505.2 [138.00]
C1HH1XS7809XXEX	3505.2 [138.00]
C1HH1XS8409XXEX	3657.6 [144.00]
C1HH1XS8410XXEX	3657.6 [144.00]
C1HH1XS9010XXEX	3810.0 [150.00]
C1HH1XS9011XXEX	3810.0 [150.00]
C1HH1XS9611XXEX	3962.4 [156.00]
C1HH1XS9612XXEX	3962.4 [156.00]
C1HH1XA212XXEX	4114.8 [162.00]
C1HH1XA213XXEX	4114.8 [162.00]

USE P/N C1HH1XSXXXXXXZ FOR 304 SS EXTENDED MAINFRAMES

CHUTE CUTOUT DETAILS	
ARM SIZE	OPERATOR SIDE DIM "C"
SS	320 [12.6]
S	370 [14.6]
M	450 [17.7]
L	480 [18.9]
LL	580 [22.8]

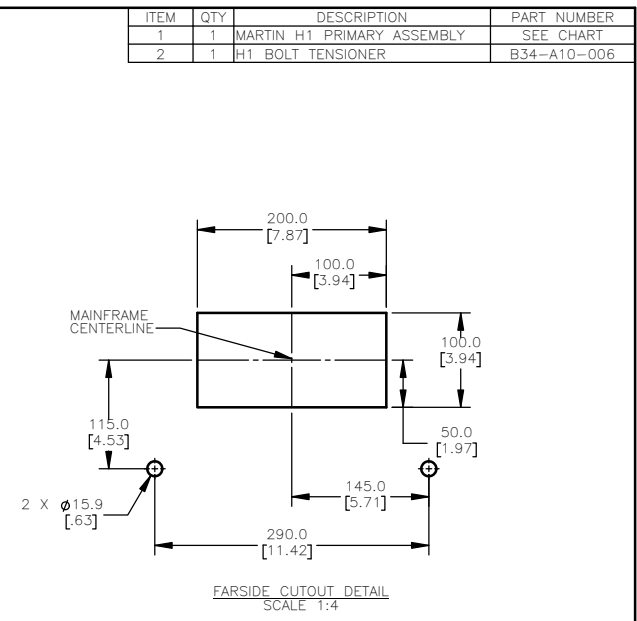
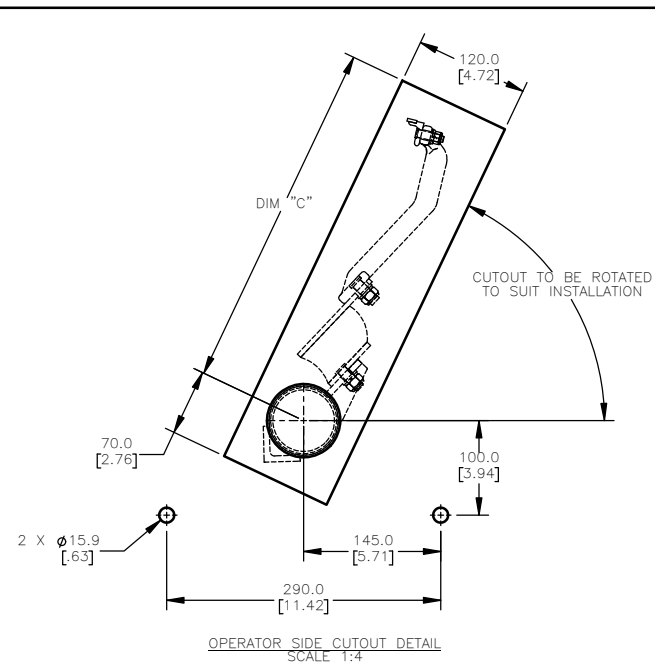

MOUNTING LOCATION CHART								
ARM SIZE	PULLEY DIA+LAGGING + BELT THICKNESS	X		Y		Z		
		MM	IN	MM	IN	MM	IN	
SS	250	9.8	185	7.3	308	12.1	31	1.2
	300	11.8	170	6.7	315	12.4	55	2.2
	350	13.8	156	6.1	321	12.6	79	3.1
	400	15.7	144	5.7	328	12.9	103	4.1
	450	17.7	132	5.2	334	13.1	127	5.0
S	500	19.7	123	4.8	341	13.4	151	5.9
	600	23.6	146	5.7	409	16.1	177	7.0
	700	27.6	127	5.0	421	16.6	225	8.9
	800	31.5	113	4.4	434	17.1	273	10.7
M	700	27.6	162	6.4	467	18.4	210	8.3
	800	31.5	145	5.7	480	18.9	258	10.2
	900	35.4	130	5.1	493	19.4	306	12.0
L	1000	39.4	118	4.6	506	19.9	355	14.0
	1100	43.3	111	4.4	542	21.3	378	14.9
	1200	47.2	100	3.9	555	21.9	427	16.8
LL	1200	47.2	189	7.4	669	26.3	418	16.5
	1300	51.2	176	6.9	682	26.9	466	18.3
	1400	55.1	164	6.5	695	27.4	514	20.2
	1500	59.1	154	6.1	708	27.9	562	22.1
	1600	63.0	145	5.7	721	28.4	611	24.1
1700	66.9	136	5.4	734	28.9	659	25.9	

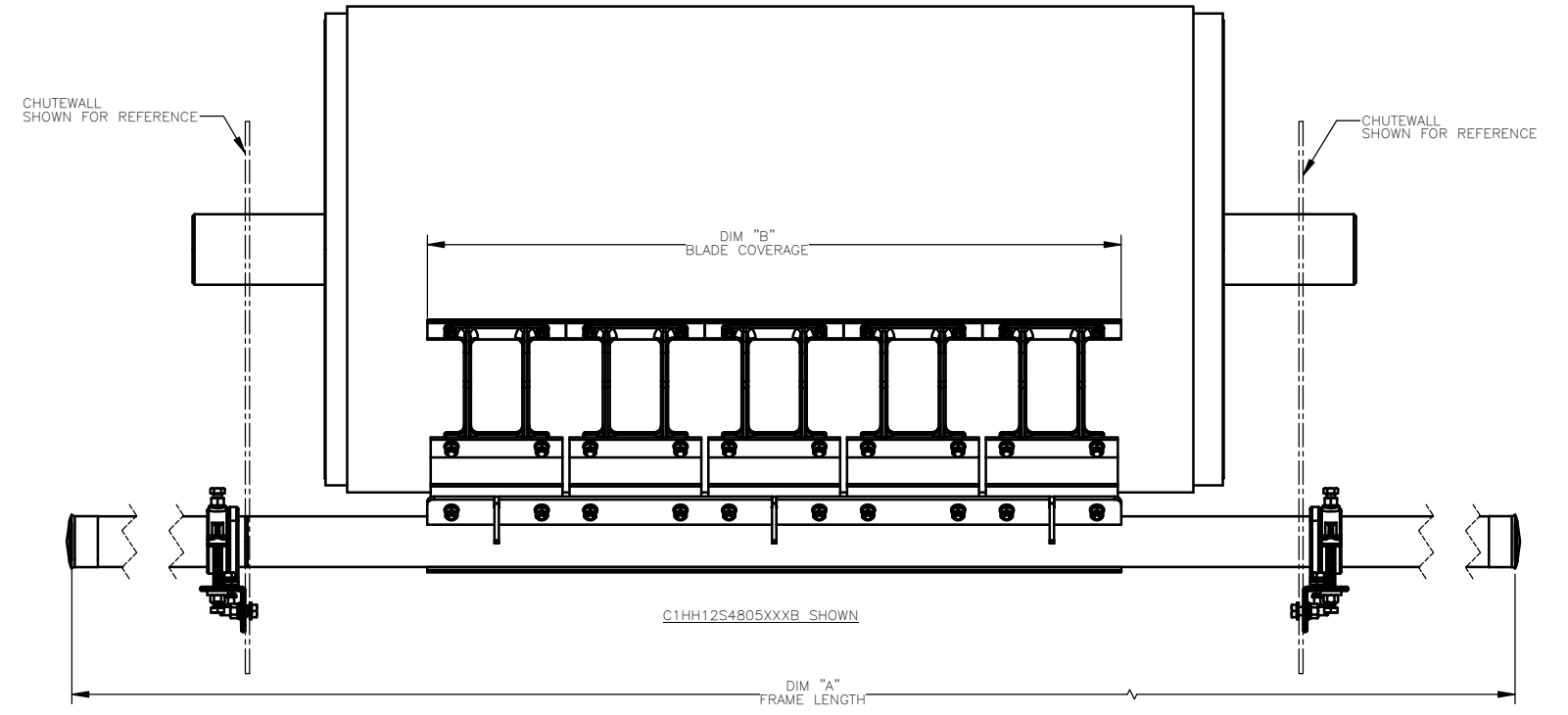
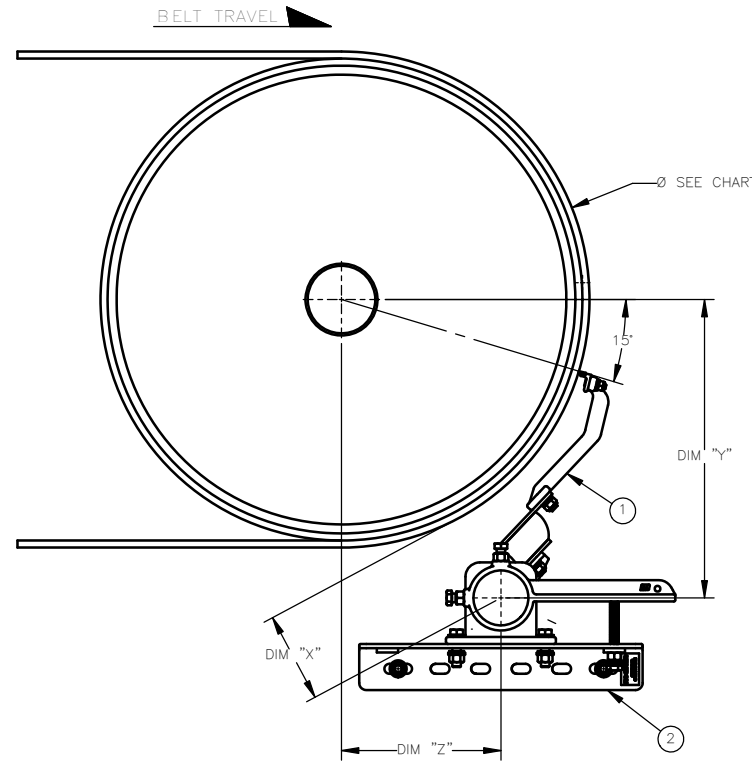

- NOTES:
- IN THE PART NUMBER, THE PREFIX C1HH1 REFERS TO:
 - C = CONVEYOR PRODUCT
 - 1 = PRIMARY CLEANER
 - H = H1 STYLE
 - H = HEAVY DUTY MAINFRAME
 - 1 = PIECE MAINFRAME
 - THE NEXT "X" INDICATES ARM TYPE
 - 1 = SS
 - 2 = S
 - 3 = M
 - 4 = L
 - 5 = LL
 - N = NONE
 - THE "SXX" INDICATES BELT WIDTH IN INCHES (18 THRU 102)
 - THE NEXT "XX" INDICATES NUMBER OF BLADES
 - THE NEXT "X" INDICATES BLADE TYPE
 - 1 = 10X3
 - 2 = 15X5
 - N = NONE
 - THE NEXT "X" INDICATES BUFFER TYPE
 - 5 = 55A SS
 - 7 = 70A SS
 - N = NONE
 - THE NEXT "X" INDICATES MAINFRAME MATERIAL
 - P = PAINTED STEEL
 - E = EXTENDED PAINTED STEEL
 - F = 304 SS
 - Z = 304 SS EXTENDED
 - THE NEXT "X" INDICATES TENSIONER
 - B = BOLT TENSIONER
 - THE EXTENDED MAINFRAME IS 305M (12 IN.) LONGER THAN STANDARD MAINFRAMES.
 - ENSURE THE BLADE TIP & MAINFRAME ARE OUT OF THE PATH OF MATERIAL TRAJECTORY.
 - CLEANER IS SHOWN IN RECOMMENDED WORKING POSITION.
 - WHERE EXTREME OR UNUSUAL CONDITIONS EXIST, CONTACT MARTIN ENGINEERING.
 - REFER TO OPERATOR'S MANUAL M4226 FOR COMPLETE INSTALLATION INSTRUCTIONS.

Copyright 2026 Martin Engineering. All rights reserved. Covered by U.S. and foreign patents pending and issued. ® and TM indicate trademarks of Martin Engineering.

MARTIN ENGINEERING
NEPONSET, IL USA

MARTIN ENGINEERING
MARTIN ENGINEERING
MARTIN ENGINEERING

MARTIN H1 PRIMARY BELT CLEANER WITH BOLT TENSIONER

DRAWN: JRB
DATE: 03/31/26
CHECKED: JRB
DATE: 04/21/26
ENG: JRB
DATE: 04/21/26
I.E.: JRB
DATE: 04/21/26
APPROVED: JRB
DATE: 04/21/26
SCALE: 3:16

REV: 1 DESCRIPTION: 2 ECN: 3 DATE: 4 BY: 5
MATERIAL: FINISH: - WEIGHT: 1199.267 Kg
UNLESS OTHERWISE SPECIFIED, TOLERANCES IN MM [INCH]: SURFACE FINISH: ✓
DIMENSIONS ARE IN MM [INCH] .X = ±.1 .XX = ±.05 .XXX = ±.025 ANGULAR: ±1
DIMENSIONS FOR REFERENCE ONLY .XXX = ±.025 DRAFT ANGLE: -

DRAWING NUMBER: PR14890D S50156-B