

PART NUMBER	BELT WIDTH	DIM "A" FRAME LENGTH	EXTENDED FRAME LENGTH	BLADE DIM "B" COVERAGE
C1QCF1S54S4XXPX	1371.6 [54.00]	2133.6 [84.00]	2590.8 [102.00]	1270.0 [50.00]
C1QCF1S54S6XXPX	1371.6 [54.00]	2133.6 [84.00]	2590.8 [102.00]	1219.2 [48.00]
C1QCF1S54S8XXPX	1371.6 [54.00]	2133.6 [84.00]	2590.8 [102.00]	1168.4 [46.00]
C1QCF1S60S4XXPX	1524.0 [60.00]	2286.0 [90.00]	2743.2 [108.00]	1422.4 [56.00]
C1QCF1S60S6XXPX	1524.0 [60.00]	2286.0 [90.00]	2743.2 [108.00]	1371.6 [54.00]
C1QCF1S60S8XXPX	1524.0 [60.00]	2286.0 [90.00]	2743.2 [108.00]	1320.8 [52.00]
C1QCF1S66S4XXPX	1676.4 [66.00]	2438.4 [96.00]	2895.6 [114.00]	1574.8 [62.00]
C1QCF1S66S6XXPX	1676.4 [66.00]	2438.4 [96.00]	2895.6 [114.00]	1524.0 [60.00]
C1QCF1S66S8XXPX	1676.4 [66.00]	2438.4 [96.00]	2895.6 [114.00]	1473.2 [58.00]
C1QCF1S72S4XXPX	1828.8 [72.00]	2590.8 [102.00]	3048.0 [120.00]	1727.2 [68.00]
C1QCF1S72S6XXPX	1828.8 [72.00]	2590.8 [102.00]	3048.0 [120.00]	1676.4 [66.00]
C1QCF1S72S8XXPX	1828.8 [72.00]	2590.8 [102.00]	3048.0 [120.00]	1625.6 [64.00]

BLADE COLOR CHART	
ASSEMBLY PART NO.	BLADE COLOR
C1QCHBSXXSXOX	ORANGE
C1QCHBSXXSXBX	BROWN
C1QCHBSXXSXTX	TAN
C1QCHBSXXSXGX	GREEN
C1QCHBSXXSXNX	NAVY BLUE
C1QCHBSXXSXCX	SOL YELLOW W/CERAMIC BEADS

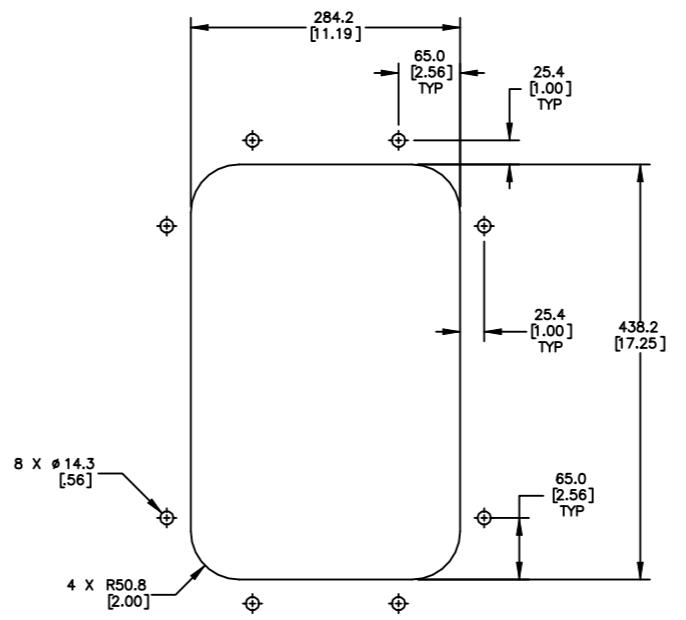
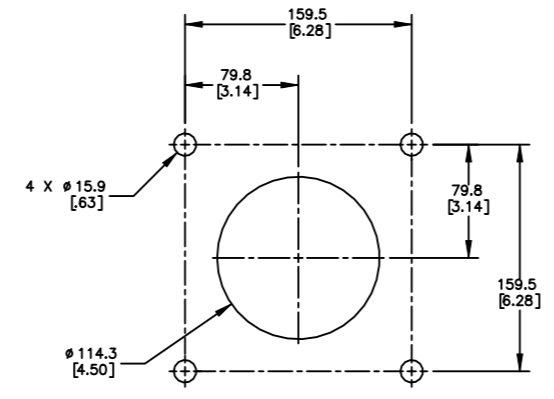

ITEM	QTY.	DESCRIPTION	PART NUMBER
1	1	MARTIN QC1+ PD BLADE MAINFRAME ASM	SEE CHART
2	1	MARTIN DUAL UNIVERSAL SPRING TENSIONER	38003-2
3	1	MARTIN LOW PROFILE ACCESS DOOR	CYA-1218XXXX

- NOTES:
- ALL DIMENSIONS ARE GIVEN IN MM [INCHES]. ALL DIMENSIONS ARE FOR REFERENCE ONLY. INCH UNITS FOR BELT WIDTHS 54-72.
 - IN THE C1QCF1 PART NUMBER THE FIRST SXX INDICATES THE BELT WIDTH IN STANDARD INCH UNITS FOR BELT WIDTHS 54-72.
S54 = 54
S66 = 66
S72 = 72
THE NEXT SX INDICATES THE LESS BELT WIDTH BLADE COVERAGE IN STANDARD INCH UNITS.
00 = NO BLADE
S4 = 4 LESS BELT WIDTH
S6 = 6 LESS BELT WIDTH
S8 = 8 LESS BELT WIDTH
 - THE FOURTH X IN THE PART NUMBER INDICATES THE BLADE COLOR:
0 = NO BLADE
B = BROWN
T = TAN
G = GREEN
N = NAVY BLUE
O = ORANGE
C = YELLOW W/CERAMIC BEADS (72.00 MAX. BLADE WIDTH)
 - THE FIFTH X INDICATES IF THE BLADE IS SOLID OR SEGMENTED:
0 = SEGMENTED BLADE / NO BLADE
1 = SOLID BLADE
 - THE P IN THE PART NUMBER INDICATES A PAINTED STEEL MAINFRAME. THE E IN THE PART NUMBER INDICATES AN EXTENDED STEEL MAINFRAME. THE LAST X INDICATES THE TENSIONER OPTION:
BLANK = NO TENSIONER
S = DUAL UNIVERSAL SPRING TENSIONER (38003-2)
 - CUT MAINFRAME TO LENGTH, WITH BLADE CENTERED ON THE BELT MEASURE HOW FAR THE MAINFRAME IS OUTSIDE THE CHUTE WALL AND ADD 1.63 [41] MINIMUM TO CUT OFF.
 - THE PRE-CLEANER BLADE IS DESIGNED FOR HEAD PULLEY'S WITH A MINIMUM EFFECTIVE DIAMETER OF 12.00 [305].
 - CLEANER IS SHOWN IN RECOMMENDED WORKING POSITION.
 - WHERE EXTREME OR UNUSUAL CONDITIONS EXIST OR SPECIAL MAINFRAME LENGTHS ARE REQUIRED CONTACT MARTIN ENGINEERING.
 - SPRING TENSIONER MAY BE BOLTED OR WELDED IN PLACE. MARTIN ENGINEERING RECOMMENDS BOLTING WHEN APPLICABLE FOR EASIER MAINTENANCE AND ACCESSIBILITY.
 - REFER TO OPERATOR'S MANUAL M4171 FOR COMPLETE INSTALLATION INSTRUCTIONS.
 - FOR BELT WIDTHS 48.00 [1200-1400] AND UNDER, MARTIN ENGINEERING RECOMMENDS USING A SPRING TENSIONER (P/N 38003).
 - CLEANER CAN BE LOCATED ANYWHERE ALONG THE ARC, AS LONG AS THE MAINFRAME IS OUT OF MATERIAL TRAJECTORY AND THE BLADE TIPS ARE BELOW THE HORIZONTAL CENTERLINE OF THE HEAD PULLEY.
 - THE PD QC #1 PRE-CLEANER BLADES ARE DESIGNED TO REMOVE HEAVY CARRYBACK ONLY. DO NOT OVERTENSION.
 - BLADE COVERAGE IS LESS THAN BELT WIDTH, DUE TO POSSIBLE MISTRACKING OR DAMAGED EDGES OF THE BELT.

MOUNTING LOCATION CHART	
Ø DIM "C" HEAD PULLEY DIA. INCLUDING BELT AND LAGGING	DIM "D"
305 [12.00] THRU 381 [15.00]	102 [4.00]
406 [16.00] AND OVER	89 [3.50]

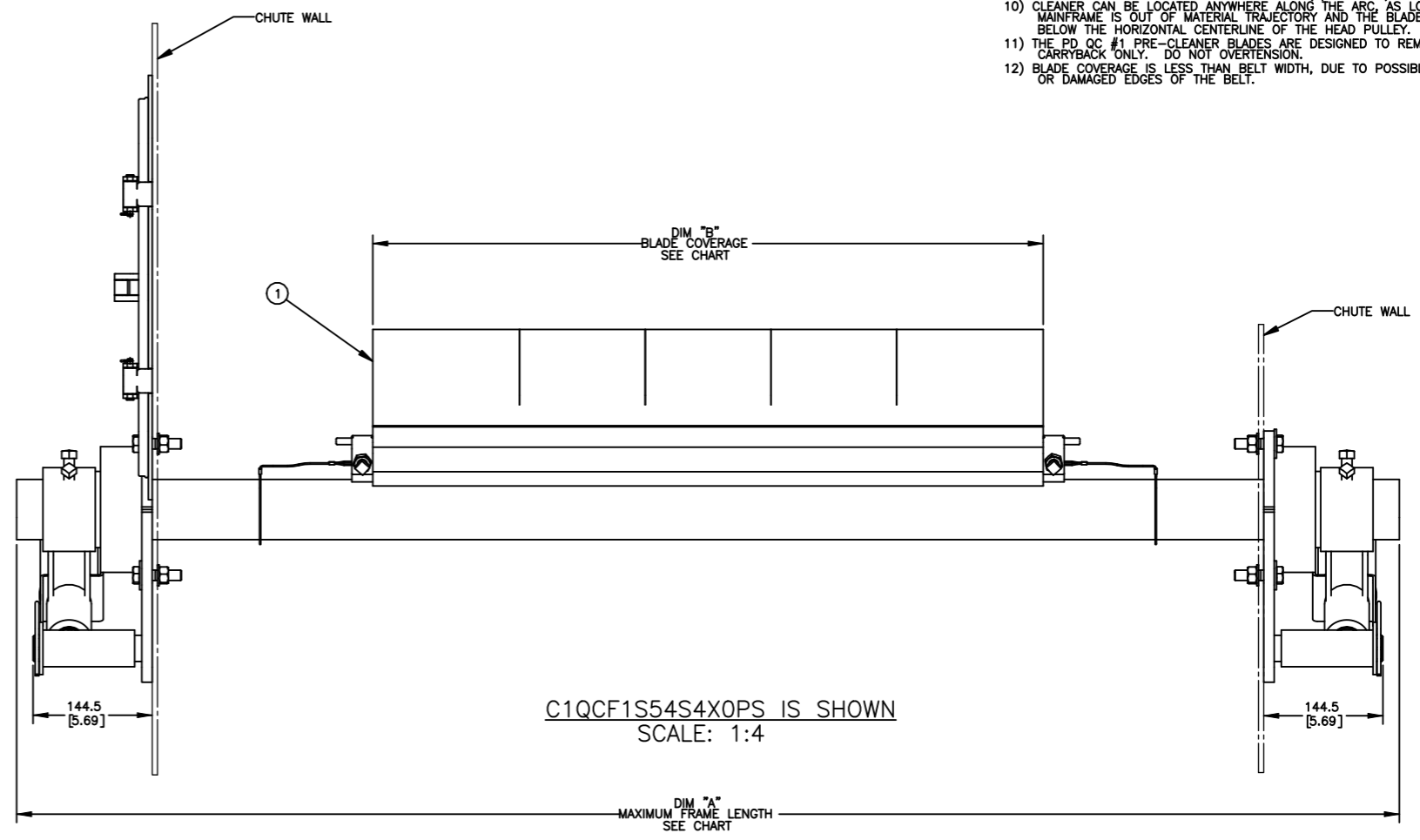
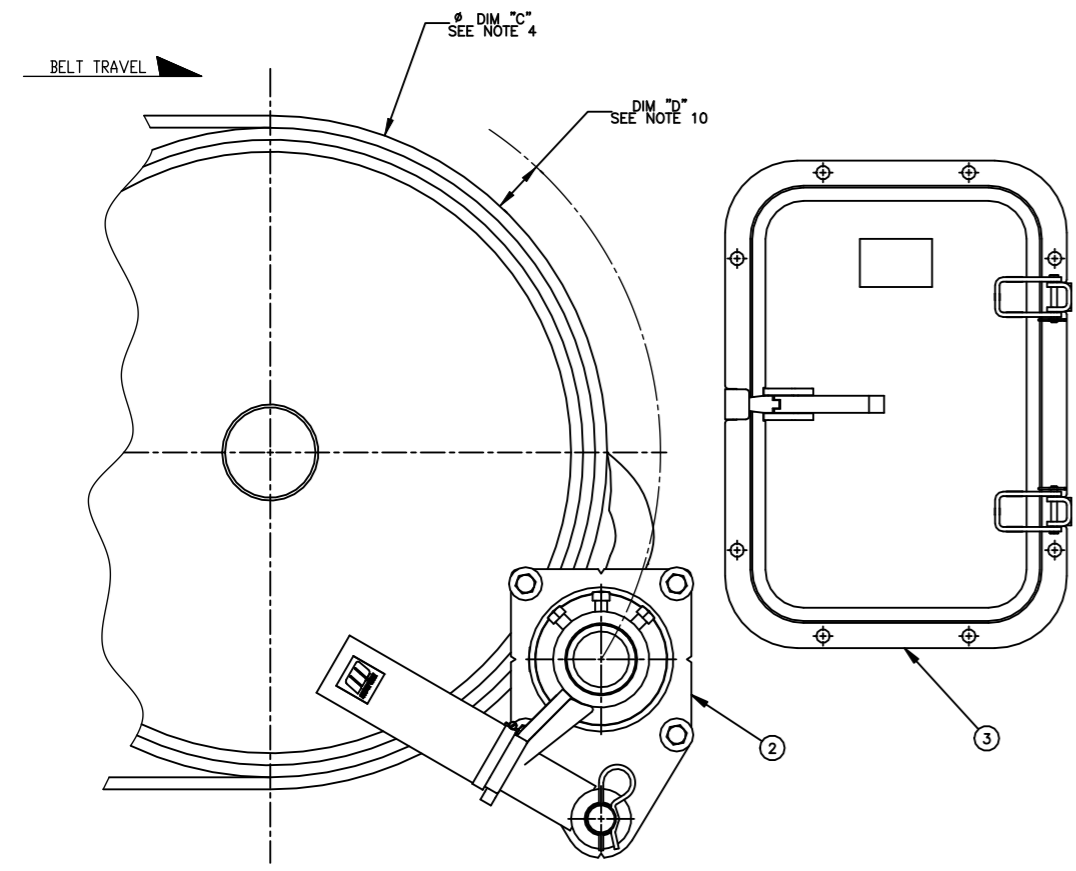

© Copyright 2021 Martin Engineering. All rights reserved. Covered by U.S. and foreign patents pending and issued. ® and ™ indicate trademarks of Martin Engineering.

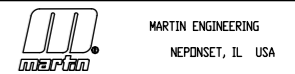

NO.	DESCRIPTION	ECN	DATE	BY
C	CHGD P/N CYA-0912 TO CYA-1218 IN BOM / CHGD DOOR CUTOUT DETAIL FROM CYA-0912 TO CYA-1218.	16025B	05/04/22	MH
B	IN NOTE B: CHNGD M3798 TO M4171.	15967	09/24/21	MH
A	ADDED (C1QCHBSXXSXCX) BLADE COLOR OPTION TO CHART & (C = YELLOW W/C) OPTION TO NOTES. (PR14194)	----	06/25/21	MH

TITLE	MARTIN QC1+ PERFORMANCE DUTY W/DUAL UNIVERSAL SPRING TENSIONER 12 X 18 ACCESS DOOR	DRAWN	MH
DATE	06/02/21	CHECKED	
ENG.		DATE	06/08/21
APPROVED		DATE	06/08/21
SALES DRAWING	PR14156B	S50142-SD	SCALE 1:4