

PART NUMBER (2ND, 3RD, AND 4TH X)	BELT WIDTH [IN]	PART NUMBER (2ND, 3RD, AND 4TH X)	BELT WIDTH [MM]
C1CSXRS18XXX	18	C1CSXR040XXX	400
C1CSXRS24XXX	24	C1CSXR045XXX	450
C1CSXRS30XXX	30	C1CSXR050XXX	500
C1CSXRS36XXX	36	C1CSXR060XXX	600
C1CSXRS42XXX	42	C1CSXR075XXX	750
		C1CSXR080XXX	800
		C1CSXR090XXX	900
		C1CSXR100XXX	1000
		C1CSXR105XXX	1050

(PART NUMBER FIRST X) TENSIONER/INSTALLATION KIT REQUIREMENTS AND MATERIAL		
PART NUMBER	TENSIONER/INSTALLATION KIT MATERIAL	P/N INSTALLATION KIT
C1CSBRXXXXXX	NO TENSIONER/BLADE ONLY	-----
C1CS TRXXXXXX	TENSIONER WITH FIXED POINT MNT BRKT STL	C1CT1ST
C1CSRRXXXXXX	TENSIONER WITH FIXED POINT MNT BRKT SS	C1CT1SS

(PART NUMBER 5TH X) BLADE CARBIDE TYPE	
PART NUMBER	APPLICATION
C1CSXRXAXX	STANDARD/MODERATE VERSION, SUITABLE FOR ABRASIVE MATERIALS AND LOW/MEDIUM BELT SPEEDS, ALLOWED FOR MECHANICAL SPLICES, HAS CHEMICAL RESISTANCE
C1CSXRXBXX	SEVERE VERSION, SUITABLE FOR HIGHLY ABRASIVE MATERIALS AND HIGH BELT SPEEDS, ALLOWED FOR MECHANICAL SPLICES
C1CSXRXCXX	EXTREME VERSION, SUITABLE FOR EXTREMELY ABRASIVE MATERIALS AND HIGHEST BELT SPEEDS, NOT ALLOWED FOR MECHANICAL SPLICES

ITEM	QTY.	DESCRIPTION	PART NUMBER
1	1	MARTIN CLEANSRAPE CLEANER ASSEMBLY	SEE CHARTS

NOTES:
1) IN THE C1C PART NUMBER:
THE S INDICATES A SMALL CLEANSRAPE BLADE/SYSTEM ASSEMBLY.
THE FIRST X INDICATES THE ASSEMBLY TYPE:
B = BLADE ASSEMBLY, NO TENSIONER
B = BLADE ASSEMBLY, TENSIONER STANDARD PAINTED STEEL
S = BLADE ASSEMBLY, TENSIONER STAINLESS STEEL
THE R INDICATES RUBBER BLADE BODY MATERIAL.
THE NEXT XXX INDICATES THE BELT WIDTH:
SXX = INCH BELT WIDTH
XXX = MM BELT WIDTH / 10
THE NEXT X INDICATES BLADE CARBIDE TYPE:
A = A CARBIDE GRADE
B = B CARBIDE GRADE
C = C CARBIDE GRADE
THE LAST XX INDICATES NUMBER OF ELEMENTS IN THE BLADE.

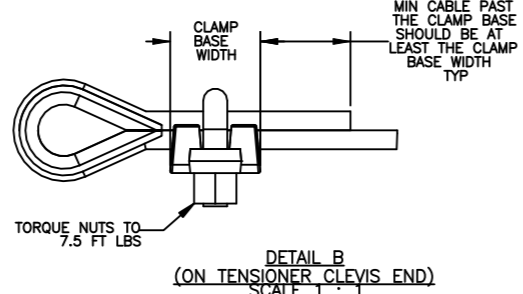

- INSTALLATION NOTES:
- BLADE CARBIDE SCRAPERS ARE MOLDED INTO THE RUBBER BODY AT AN ANGLE CREATING A SERRATED CLEANING EDGE. CLEANER MUST BE MOUNTED AT AN ANGLE AS SHOWN. THE IDEAL INSTALLATION ANGLE IS BETWEEN 17° AND 19°. ANGLES FROM 15° TO 21° ARE ACCEPTABLE BUT TENSIONER TENSION NEEDS TO BE ADJUSTED AS THE ANGLE CHANGES FROM THE IDEAL ANGLE. CLEANER MUST NOT LIE IN THE MATERIAL PATH.
 - BELT WIDTH MUST NOT EXCEED A RATIO OF 3:1 TO THE HEAD PULLEY DIAMETER. HEAD PULLEY RANGE IS 305 [12.00] MIN. TO 508 [20.00] MAX.
 - CHUTE WALLS MUST BE STRONG ENOUGH TO NOT FLEX WHEN THE CLEANER IS TENSIONED. ADDITIONAL CHUTE WALL STRUCTURE MAY BE REQUIRED TO PREVENT CHUTE WALL FROM FLEXING.
 - LOCATE AND INSTALL THE FIXED POINT MOUNT BRACKET ON THE INSIDE OF THE FAR SIDE CHUTE WALL. MEASURE THE HEAD PULLEY RADIUS PLUS THE LAGGING, BELT THICKNESS, AND ADD THE 9.6 [1.38]. THIS IS THE RADIUS ARC THAT THE FIXED POINT BRACKET WILL BE LOCATED ON. LOCATE THE FIXED POINT BRACKET LOWER MOUNTING HOLE ON THE VERTICAL CENTERLINE OF THE HEAD PULLEY (AT THE 6:00 O'CLOCK POSITION). THIS POINT MAY BE ADJUSTED (ROTATED) TO ENSURE IT DOES NOT GO PAST THE BELT EXIT POINT ON THE HEAD PULLEY. MARK THE HOLE LOCATIONS FROM THE FIXED POINT BRACKET AND DRILL THE MOUNTING HOLES (IF NOT WELDING IN PLACE). BOLT OR WELD THE FIXED POINT BRACKET TO THE INSIDE OF THE CHUTE WALL.
 - ON THE OPERATORS SIDE OF THE CHUTE WALL MARK THE LOCATION OF THE TENSIONER CUTOUTS. LOCATE THE CENTER OF THE TOP TENSIONER CUTOUT 9.7 [1.38] ABOVE THE HORIZONTAL CENTERLINE (AT THE 3:00 O'CLOCK POSITION) AND ON A RADIUS ARC 16.0 [1.63] PAST THE BELT EDGE. THE CENTER OF THE LOWER TENSIONER CUTOUT SHOULD BE ON THE SAME RADIUS ARC AS THE FIRST CUTOUT AND 90.4 [3.56] BELOW THE FIRST CUTOUT. LOCATE THE TOP CORNERS OF THE TENSIONER MOUNT PLATE ON A 28.7 [1.13] RADIUS ARC PAST THE BELT EDGE, AND THE UPPER CORNER ON THE HORIZONTAL CENTERLINE (AT THE 3:00 O'CLOCK POSITION). BOLT OR WELD THE TENSIONER MOUNT BRACKET TO THE OUTSIDE OF THE CHUTE WALL. THE TENSIONER CUTOUTS AND MOUNT PLATE MAY BE ADJUSTED (ROTATED) AS REQUIRED TO KEEP THE CLEANER BELOW THE PRODUCT DISCHARGE POINT AND AT THE SPECIFIED INSTALLATION ANGLE. THE TOP OF THE CLEANER SHOULD NOT BE ABOVE THE 2:00 O'CLOCK POSITION. SEE THE CUTOUT DETAIL. BOLT THE TENSIONER TO THE TENSIONER MOUNT BRACKET. LEAVE THE ADJUSTMENT BOLTS LOOSE AT THIS TIME.
 - MEASURE THE APPROXIMATE CABLE LENGTH AND ASSEMBLE THE CABLE THIMBLES AND CLAMPS TO THE TENSIONER END OF THE BLADE ASSEMBLY. INSTALL THE CLEANER TO THE FIXED POINT BRACKET. LEAVE THE ADJUSTMENT BOLTS LOOSE AT THIS TIME. HOLD THE CLEANER TO THE HEAD PULLEY AND ROUTE THE CABLES THROUGH THE CHUTE WALL AND HOOK ONTO THE TENSIONER. MAKE SURE THE TENSIONER ADJUSTMENT NUTS ARE AT THE END OF THE TENSIONER THREADED ROD. TIGHTEN THE TENSIONER ADJUSTMENT NUTS UNTIL THE CLEANER IS HELD FIRMLY AGAINST THE HEAD PULLEY. ADJUST THE FIXED POINT BRACKET AND TENSIONER BRACKET SO THE OUTER TWO ELEMENTS ON EACH SIDE OF THE CLEANER ARE APPROXIMATELY 3.3 [1.31] AWAY FROM THE BELT. INCREASE THE RELIEF AS NECESSARY TO ENSURE MECHANICAL SPLICES WILL PASS. TIGHTEN ALL BOLTS.
 - TENSION THE CLEANER PER THE RECOMMENDED TENSION IN THE MANUAL.
 - THE LENGTH OF THE CHAIN OR CABLE MUST NOT EXCEED 125 [5.00] ON EITHER SIDE OF THE CLEANER. EXCESS CHAIN OR CABLE COULD RESULT IN VIBRATION THAT COULD DAMAGE THE BELT OR THE CLEANER.

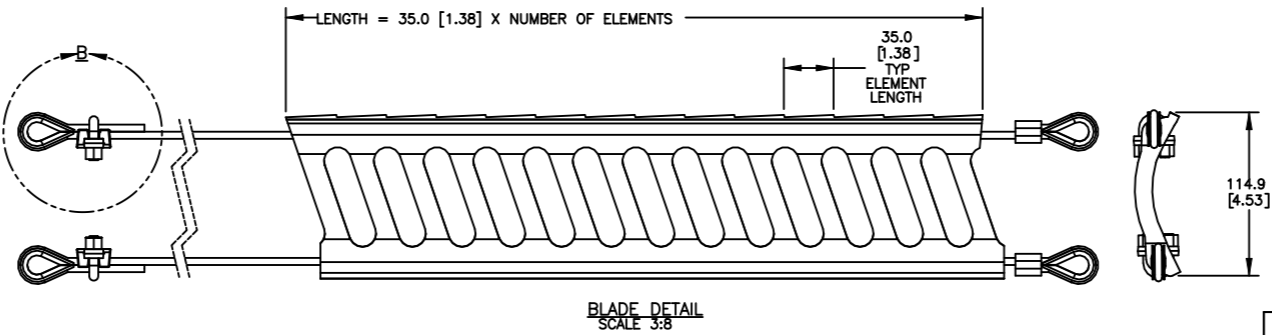
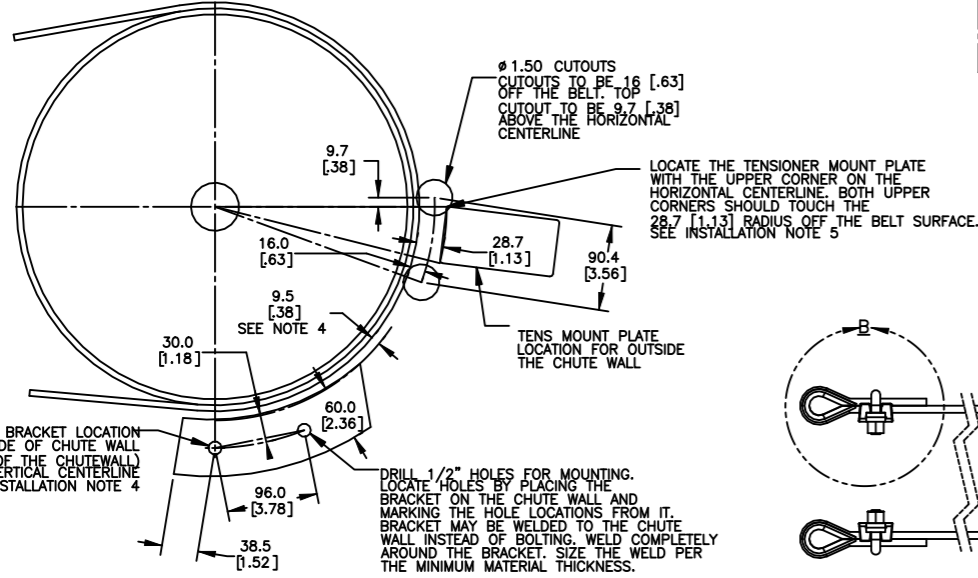
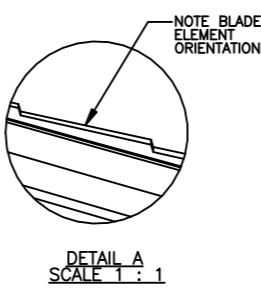
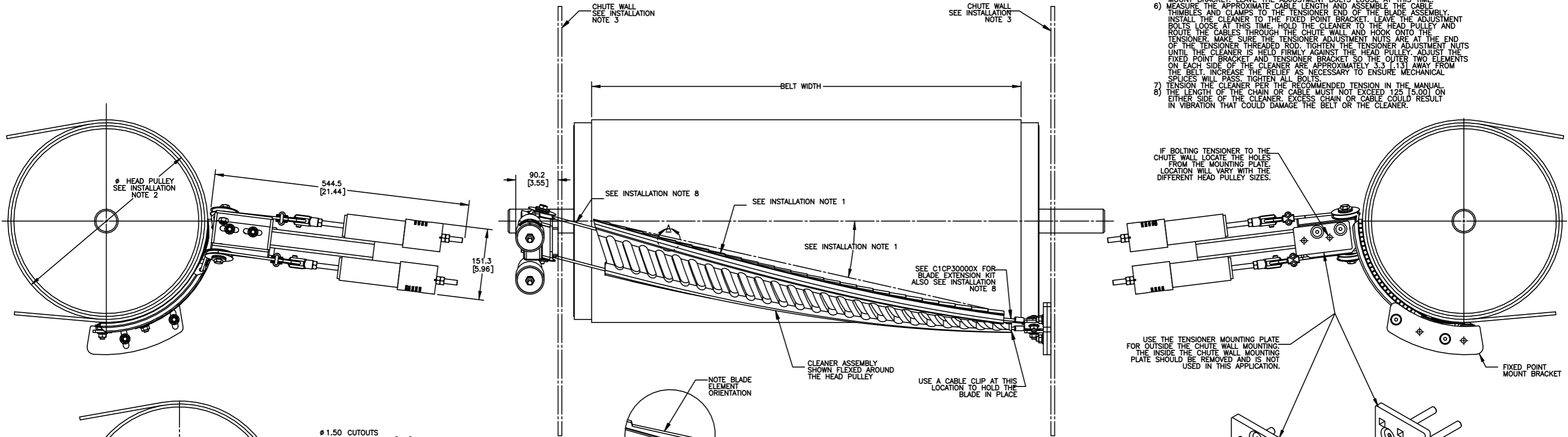

Copyright 2020 Martin Engineering. All rights reserved. Covered by U.S. and foreign patents pending and issued. ® and ™ indicate trademarks of Martin Engineering.

MARTIN ENGINEERING-USA
NEPINSSET, IL USA

TITLE	CLEANSRAPE SMALL CLEANER ASM WITH OUTSIDE THE CHUTE WALL TENSIONER	DRAWN	RND
DATE	03/16/20	CHECKED	
ENG.	PR	DATE	03/17/20
APPROVED	PR	DATE	03/17/20

SALES DRAWING PR13941 S50137-S SCALE 1:4

NO.	DESCRIPTION	ECN	DATE	BY
SOLIDWORKS	REVISION			