

TOP OF STRINGER MOUNTING DETAIL
 BOTTOM OF STRINGER MOUNTING IS SIMILAR
 DRILL HOLES IN STRINGER AS SHOWN
 CLAMP MOUNTING PIPE TO STRINGER WITH U-BOLTS
 SCALE 5:16

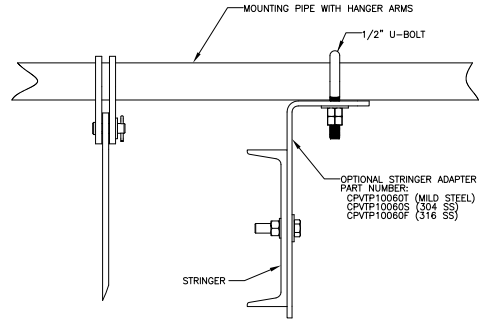

TOP OF STRINGER MOUNTING WITH OPTIONAL ADAPTER PLATE DETAIL
 BOTTOM OF STRINGER MOUNTING IS SIMILAR
 DRILL HOLES IN STRINGER AS SHOWN
 (OPTIONAL ADAPTER PLATE MAY BE WELDED TO STRINGER)
 CLAMP MOUNTING PIPE TO STRINGER ADAPTER PLATE WITH U-BOLTS
 SCALE 5:16

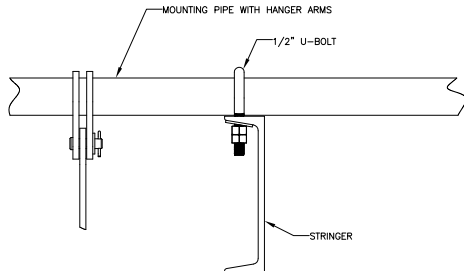
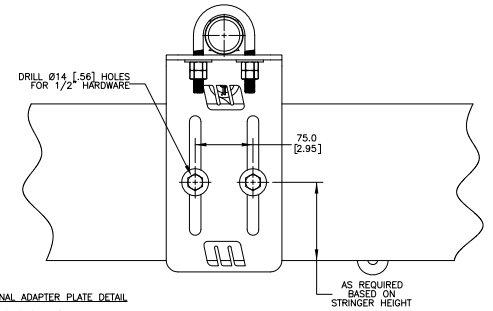

AS REQUIRED BASED ON STRINGER HEIGHT

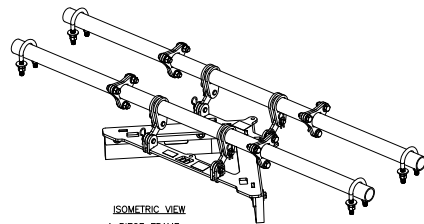

ISOMETRIC VIEW
 1 PIECE FRAME
 FRONT AND REAR HANGER BARS THE SAME
 FOR BELT WIDTHS 18 AND 24
 (SHOWN WITH BOLT ON URETHANE BLADE)
 SCALE 1:3

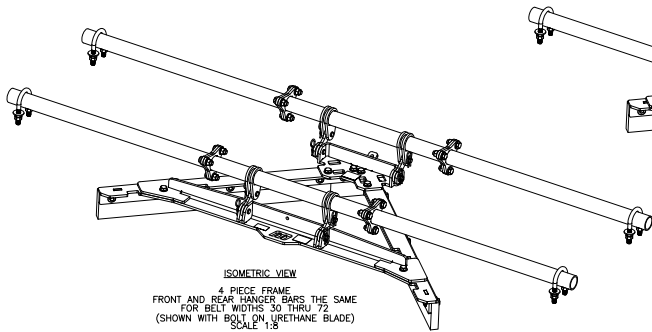

ISOMETRIC VIEW
 4 PIECE FRAME
 FRONT AND REAR HANGER BARS THE SAME
 FOR BELT WIDTHS 30 THRU 72
 (SHOWN WITH BOLT ON URETHANE BLADE)
 SCALE 1:3

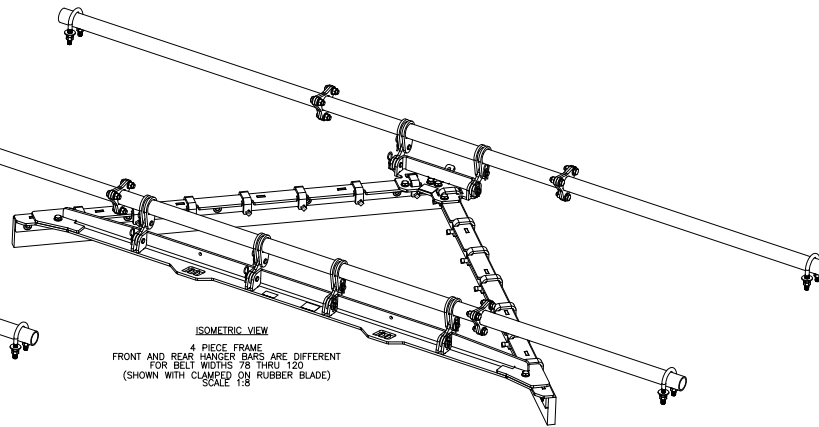

STRINGER MOUNTING WITH OPTIONAL HUB MOUNT DETAIL
 SCALE 5:16

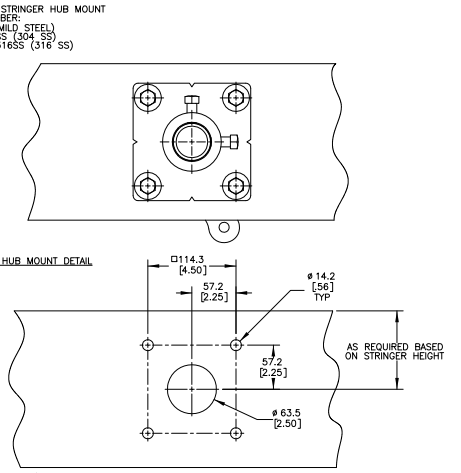

OPTIONAL HUB MOUNT STRINGER MOUNTING CUTOUT DETAIL

DRILL HOLES IN STRINGER AS SHOWN
 (OPTIONAL HUB MOUNT MAY BE WELDED TO STRINGER)
 SCALE 5:16

AS REQUIRED BASED ON STRINGER HEIGHT

NOTES:
 1) ALL DIMENSIONS ARE GIVEN IN MILLIMETERS [INCHES].
 2) ALL DIMENSIONS ARE FOR REFERENCE ONLY.

© Copyright 2018 Martin Engineering. All rights reserved. Covered by U.S. and foreign patents pending and issued. © and TM indicate trademarks of Martin Engineering.

MARTIN ENGINEERING-USA NEPONSET, IL USA		DRAWN: RND DATE: 09/13/18 CHECKED: ENG: JAP DATE: 9/20/2018 APPROVED: JES DATE: 9/27/2018
TITLE: V-PLOW MODULAR ASSEMBLY		SALES DRAWING
NO. 15718	ECH: 08/27/20	DATE: 11/06/19
NO. 15317	ECH: 02/25/19	DATE: 02/25/19
NO. 15317	ECH: 02/25/19	DATE: 02/25/19
NO. 15317	ECH: 02/25/19	DATE: 02/25/19

NO.	DESCRIPTION	REVISION	ECH	DATE	BY
C	ADDED SHEET 4		15718	08/27/20	MH
B	(SHT 1 & 2) ADDED HUB MOUNT KIT OPTIONS TO NOTE (SHT 3) ADDED OPTIONAL HUB MOUNT DETAILS			11/06/19	JAH
A	(SHT 1 & 2) UPDATED DIM 72" & DIM 70" IN CHART / (SHT 3) ADDED PIPE EAR LEADER NOTE		15317	02/25/19	RND

SOLUTIONS: PR13654 REVISION: S50126 SCALE: 5:32