

INSTALLATION DETAIL

ALL DIMENSIONS TYPICAL
EACH SIDE OF CONVEYOR
ON ALL LAYOUTS

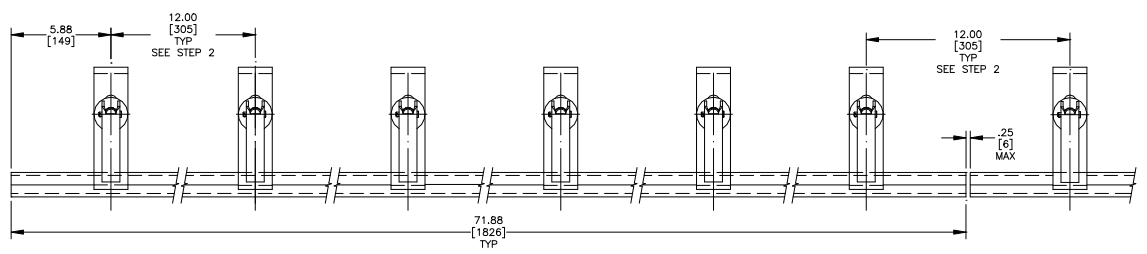
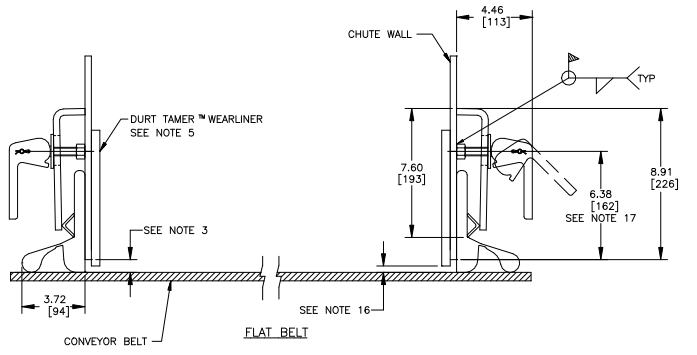
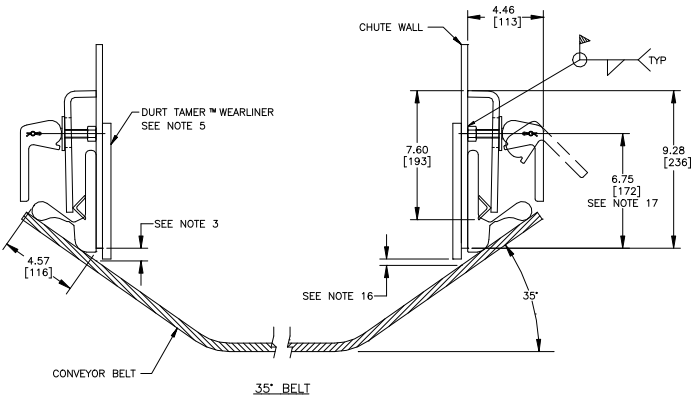
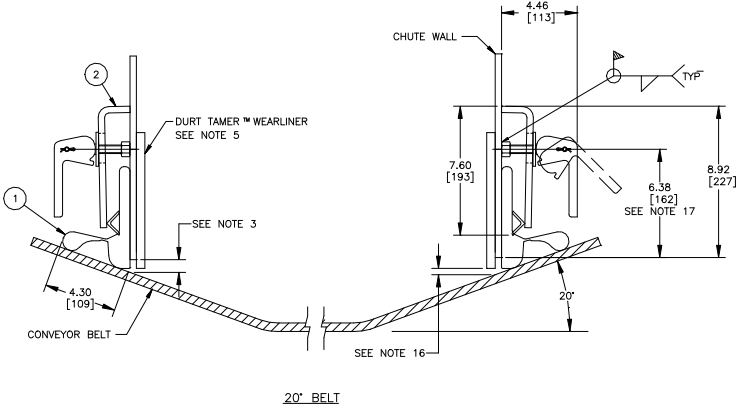
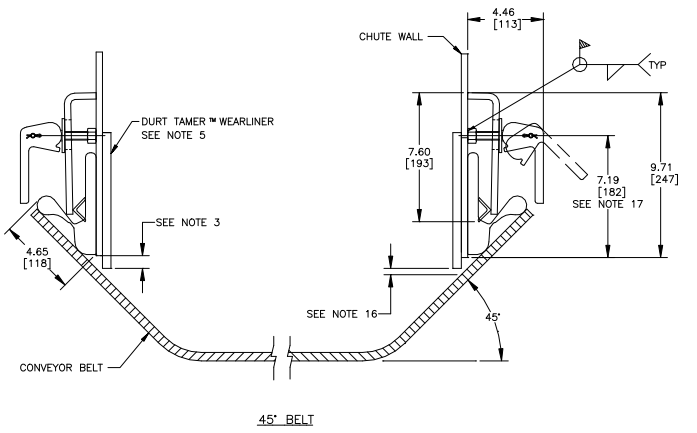

ANGLE CLAMP DETAIL

ITEM	QTY.	DESCRIPTION	PART NUMBER
1	**	APRON SEAL™ 1-PC XHD W/6.00 HI BACK	100845
2	**	ANGLE CLAMP WLDMT W/HARDWARE	32049-QRH

* - SPECIFY LENGTH NEEDED IN FEET.
** - EACH WELDMENT IS 71.88 [1826] LONG. (1) WELDMENT REQUIRED PER EVERY 6'-0" [1829] OF 1-PC XHD APRON SEAL™ (ITEM 1). (1) STUD, NUT, AND QUICK RELEASE CLAMP IS SUPPLIED WITH ITEM 2 FOR EACH FOOT OF 1-PC XHD APRON SEAL™. NUT IS WELDED TO THE CHUTE WALL AND THEN INSERT THE STUD.

- NOTES:
- 1) ALL DIMENSIONS ARE GIVEN IN INCHES [MM].
 - 2) ALL DIMENSIONS ARE FOR REFERENCE ONLY.
 - 3) MARTIN ENGINEERING RECOMMENDS CHUTE WALL TO BE WITHIN .75 [19] OF BELT.
 - 4) A MIN. OF 10.00 [254] VERTICAL AND 4.00 [102] HORIZONTAL CLEARANCE REQUIRED TO INSTALL 1-PC XHD APRON SEAL™ AND ANGLE CLAMPS WITH QUICK RELEASE CLAMPS.
 - 5) TO PROVIDE AN EFFECTIVE SEAL, DURT TAMER™ WEARLINERS (STRAIGHT OR DEFLECTOR) ARE RECOMMENDED TO PREVENT THE MAIN LOAD FROM CONTACTING THE 1-PC XHD APRON SEAL™ (STRAIGHT WEARLINER SHOWN).
 - 6) IF DURT TAMER™ WEARLINERS ARE BOLTED TO CHUTE WALL, 1-PC XHD APRON SEAL™ AND ANGLE CLAMPS ARE TO BE MOUNTED IN A MANNER AS TO ALLOW EASY ACCESS TO BOLTS.
 - 7) 1-PC XHD APRON SEAL™ IS DESIGNED AS A DUST SEAL ONLY. IT IS NOT TO BE USED AS A MATERIAL HOLDBACK OR LOAD CARRYING SURFACE.
 - 8) BELT MUST NOT LIFT OFF IDLERS DURING START-UP OR WHILE BELT IS IN OPERATION.
 - 9) BELT MUST TRACK PROPERLY TO PREVENT IT FROM RUNNING BEHIND 1-PC XHD APRON SEAL™.
 - 10) CONSULT MARTIN ENGINEERING FOR INSTALLATIONS WITH UNUSUAL OR SEVERE CONDITIONS, I.E.: CONCAVE/CONVEX CURVES, EXTREME SIDE PRESSURE, UNUSUALLY FAST OR SLOW MOVING BELTS, TEMPERATURE EXTREMES, ETC.
 - 11) 1-PC XHD APRON SEAL™ AND DURT TAMER™ WEARLINER SHOULD BEGIN AT LEAST 12.00 [305] BEFORE INLET SIDE OF CHUTE WALL.
 - 12) CONTACT MARTIN ENGINEERING PRIOR TO MOUNTING THESE PRODUCTS IN ANY WAY OTHER THAN WHAT IS DEPICTED ON THIS DRAWING OR IN OPERATOR'S MANUAL (M3248).
 - 13) ANGLE CLAMP WELDMENT (ITEM 2) IS TO BE FULLY TIGHTENED AGAINST CHUTE WALL.
 - 14) ANGLE CLAMP WELDMENT MUST HAVE FIRM BACKING TO ENSURE PROPER CLAMP FORCE.
 - 15) REFER TO OPERATOR'S MANUAL M3248 DURING INSTALLATION. THIS DRAWING NOT TO BE USED IN PLACE OF OPERATOR'S MANUAL.
 - 16) .38 [10] MAX. IN IMPACT AREA, TAPERING TO .75 [19] AT THE EXIT AREA.
 - 17) FOR FLAT TO 35° BELTS USE PRE-FAB CHUTE WALL P/N 33564-35. FOR 45° BELTS USE P/N 33564-45.
 - 18) QUICK RELEASE CLAMP (P/N 36273) HANDLE CAN BE LOCKED INTO ANY ORIENTATION.

INSTALLATION INSTRUCTIONS

- STEP 1: SCRIBE A LINE PARALLEL TO BELT SURFACE 6.38 [162] ABOVE BELT. (NOTE: 35° BELT USE 6.75 [172] AND 45° BELT USE 7.19 [182]).
- STEP 2: ALONG THIS LINE, MAKE FIRST MARK 5.88 [150] FROM END OF CHUTE WALL AND MARK EVERY 12.00 [305].
- STEP 3: ON THESE MARKED CENTERS, WELD 1/2" NUTS. INSTALL STUDS INTO WELDED NUTS. MAKE SURE THAT STUDS ARE PERPENDICULAR TO THE CHUTE WALL TO ENSURE EVEN CLAMP CONTACT.
- STEP 4: PLACE 1-PC XHD APRON SEAL™ AGAINST CHUTE WALL, MAKING SURE IT IS IN CONTINUOUS CONTACT WITH BELT. PLACE ANGLE CLAMP WELDMENT OVER PREVIOUSLY INSTALLED STUDS.
- STEP 5: PUSH ANGLE CLAMP WELDMENT TIGHT AGAINST 1-PC XHD APRON SEAL™ AND INSTALL QUICK RELEASE CLAMPS.

© Copyright 2018 Martin Engineering. All rights reserved. Covered by U.S. and foreign patents pending and issued. ® and TM indicate trademarks of Martin Engineering.

MARTIN ENGINEERING
NEPONSET, IL USA

TITLE	1-PC EXTRA HEAVY DUTY APRON SEAL™ WITH 6.00 HI BACK AND QUICK RELEASE CLAMPS	DRAWN PND	02/26/18
CHECKED		DATE	02/27/18
ENG.	JAP	APPROVED	JAP
DATE	02/27/18	SCALE	1/4"

NO.	DESCRIPTION	ECN	DATE	BY

AutoCAD M00900 S50125-QR SCALE 1/4"