

QTY.	DESCRIPTION	PART NUMBER
1	HD DOUBLE APRON SEAL™	100861
2	CENTER PIVOT CLAMP WELDMENT	38789

INSTALLATION DETAIL
 ALL DIMENSIONS TYPICAL
 EACH SIDE OF CONVEYOR
 ON ALL LAYOUTS

* - SPECIFY LENGTH NEEDED IN FEET.
 ** - EACH WELDMENT IS 35.88 [911] LONG. (1) WELDMENT REQUIRED PER EVERY 3'-0" [914] OF HD DOUBLE APRON SEAL™ [P/N 100861].

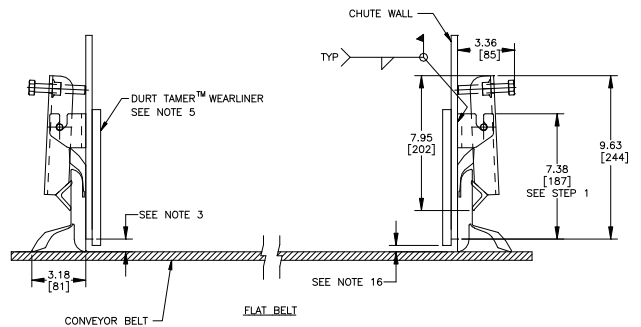
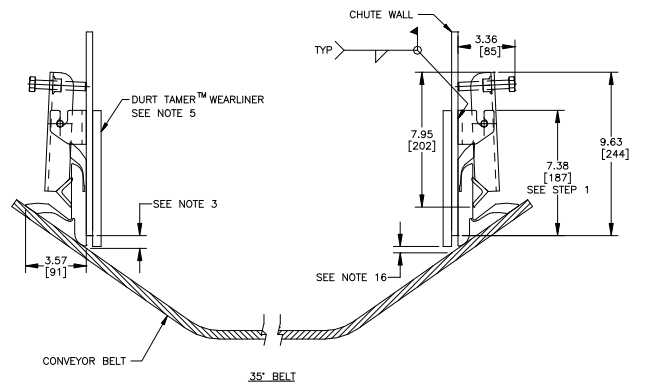
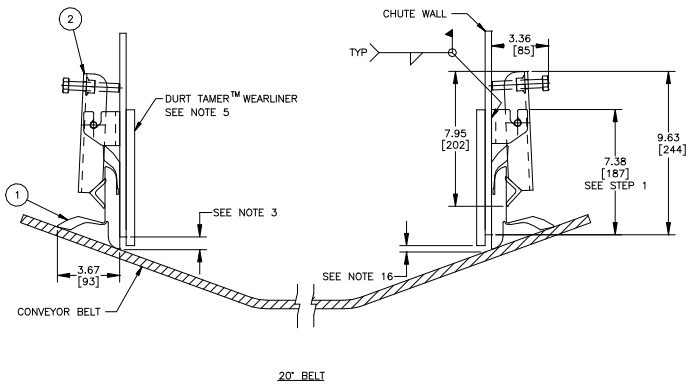
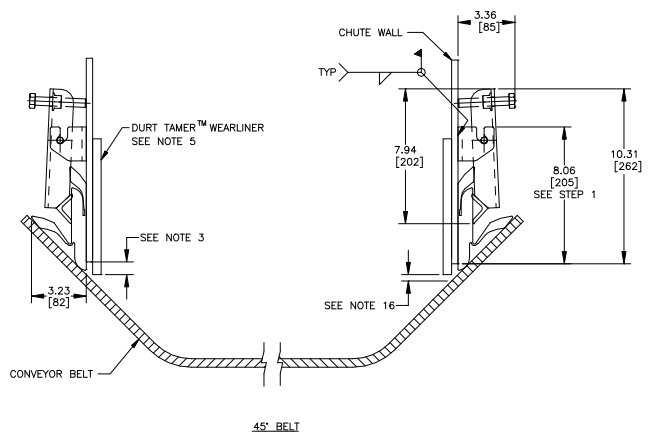

- NOTES:**
- 1) ALL DIMENSIONS ARE GIVEN IN INCHES (MM).
 - 2) ALL DIMENSIONS ARE FOR REFERENCE ONLY.
 - 3) MARTIN ENGINEERING RECOMMENDS CHUTE WALL TO BE WITHIN .75 (19) OF BELT.
 - 4) A MIN. OF 10.00 (254) VERTICAL AND 4.00 (102) HORIZONTAL CLEARANCE REQUIRED TO INSTALL APRON SEAL™ & CENTER PIVOT CLAMPS.
 - 5) TO PROVIDE AN EFFECTIVE SEAL, DURT TAMER™ WEARLINERS (STRAIGHT OR DEFLECTOR) ARE RECOMMENDED TO PREVENT THE MAIN LOAD FROM CONTACTING THE APRON SEAL™ (STRAIGHT WEARLINER SHOWN).
 - 6) IF DURT TAMER™ WEARLINERS ARE BOLTED TO CHUTE WALL, APRON SEAL™ AND CENTER PIVOT CLAMPS ARE TO BE MOUNTED IN A MANNER AS TO ALLOW EASY ACCESS TO BOLTS.
 - 7) APRON SEAL™ IS DESIGNED AS A DUST SEAL ONLY. IT IS NOT TO BE USED AS A MATERIAL HOLDBACK OR LOAD CARRYING SURFACE.
 - 8) BELT MUST NOT LIFT OFF IDLERS DURING START-UP OR WHILE BELT IS IN OPERATION.
 - 9) BELT MUST TRACK PROPERLY TO PREVENT IT FROM RUNNING BEHIND APRON SEAL™.
 - 10) CONSULT MARTIN ENGINEERING FOR INSTALLATIONS WITH UNUSUAL OR SEVERE CONDITIONS, I.E.: CONCAVE/CONVEX CURVES, EXTREME SIDE PRESSURE, UNUSUALLY FAST OR SLOW MOVING BELTS, TEMPERATURE EXTREMES, ETC.
 - 11) APRON SEAL™ AND DURT TAMER™ WEARLINER SHOULD BEGIN AT LEAST 12.00 (305) BEFORE INLET SIDE OF CHUTE WALL.
 - 12) CONTACT MARTIN ENGINEERING PRIOR TO MOUNTING THESE PRODUCTS IN ANY WAY OTHER THAN WHAT IS DEPICTED ON THIS DRAWING OR IN OPERATOR'S MANUAL (M3248).
 - 13) CENTER PIVOT CLAMP WELDMENT (ITEM 2) IS TO BE FULLY TIGHTENED AGAINST CHUTE WALL.
 - 14) CENTER PIVOT CLAMP WELDMENT MUST HAVE FIRM BACKING TO ENSURE PROPER CLAMP FORCE.
 - 15) REFER TO OPERATOR'S MANUAL M3248 DURING INSTALLATION. THIS DRAWING NOT TO BE USED IN PLACE OF OPERATOR'S MANUAL.
 - 16) .38 (10) MAX. IN IMPACT AREA, TAPERING TO .75 (19) AT EXIT AREA.

INSTALLATION INSTRUCTIONS

- STEP 1: SCRIBE A LINE PARALLEL TO BELT SURFACE 7.38 (187) ABOVE BELT.
 NOTE: 45° BELT USE 8.06 (205)
- STEP 2: ALONG THIS LINE, MAKE FIRST MARK 7.32 (186) FROM END OF CHUTE WALL AND MARK EVERY 18.00 (457).
- STEP 3: ON THESE MARKS WELD THE EDGE OF THE CENTER PIVOT MOUNT PLATE. WHEN WELDING MAKE SURE THAT THEY ARE IN LINE WITH EACH OTHER TO ENSURE THE CENTER PIVOT IS IN LINE.
- STEP 4: PLACE APRON SEAL™ AGAINST CHUTE WALL, MAKING SURE IT IS IN CONTINUOUS CONTACT WITH BELT. PLACE CENTER PIVOT CLAMP WELDMENT INTO THE MOUNT PLATES.
- STEP 5: PUSH CENTER PIVOT CLAMP WELDMENT TIGHT AGAINST APRON SEAL™ AND ADJUST LOCKING BOLT. TIGHTEN BOLTS TO 40 FT/LBS.

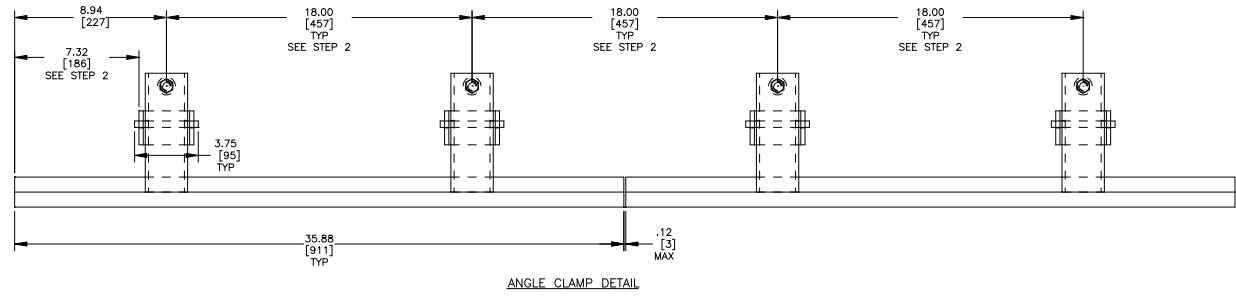

ANGLE CLAMP DETAIL

© Copyright 2010 Martin Engineering. All rights reserved. Covered by U.S. and foreign patents pending and issued. ® and ™ Indicate trademarks of Martin Engineering.

MARTIN ENGINEERING NEPONSET ILLINOIS USA

TITLE	MARTIN® HEAVY DUTY DOUBLE APRON SEAL™ W/CENTER PIVOT CLAMP INSTALLATION DRAWING	DRAWN RND	DATE 12/08/10
CHECKED	ENG. JEP	CHECKED	DATE 12/09/10
APPROVED	DATE 01/17/11	SCALE	1/4

NO.	DESCRIPTION	ECN	DATE	BY	SALES DRAWING

AutoCAD REVISION

PR11915

S50083-DH