

INSTALLATION DETAIL
 ALL DIMENSIONS TYPICAL
 EACH SIDE OF CONVEYOR
 ON ALL LAYOUTS

ITEM	QTY.	DESCRIPTION	PART NUMBER
1	*	HD DOUBLE APRON SEAL™	100861
2	**	ANGLE CLAMP WELDMENT	32049
3	***	STUD 1/2-13NC x 3	31189
4	***	NUT FLANGE LOCKING 1/2-13NC	18843
5	***	NUT HEX 1/2-13NC	34134

* - SPECIFY LENGTH NEEDED IN FEET.
 ** - EACH WELDMENT IS 71.88(1826) LONG. (1) WELDMENT REQUIRED PER EVERY 6'-0"(1829) OF 1-PC DOUBLE APRON SEAL™ (ITEM 1).
 *** - (1) STUD (ITEM 3), (1) NUT (ITEM 4) AND (1) NUT (ITEM 5) ARE SUPPLIED FOR EACH FOOT OF 1-PC DOUBLE APRON SEAL™. (1) NUT IS USED TO HOLD THE ANGLE CLAMP IN PLACE ON THE STUD, THE OTHER IS WELDED TO THE TO THE CHUTE WALL AND THEN INSERT THE STUD.

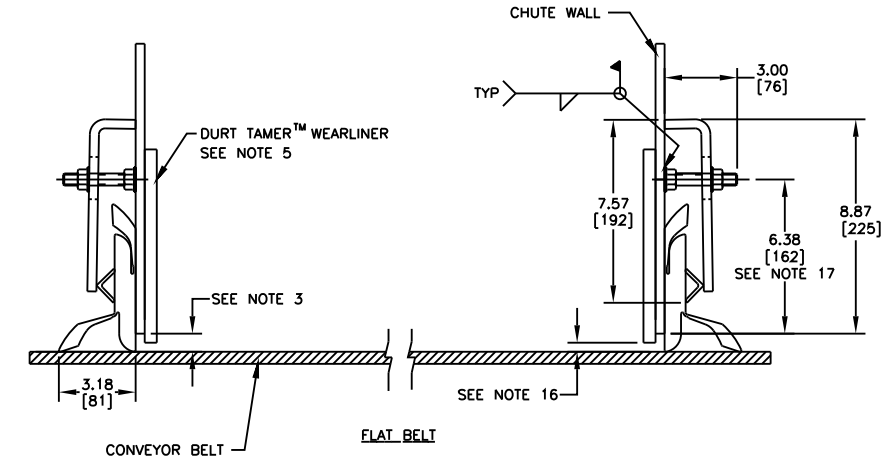
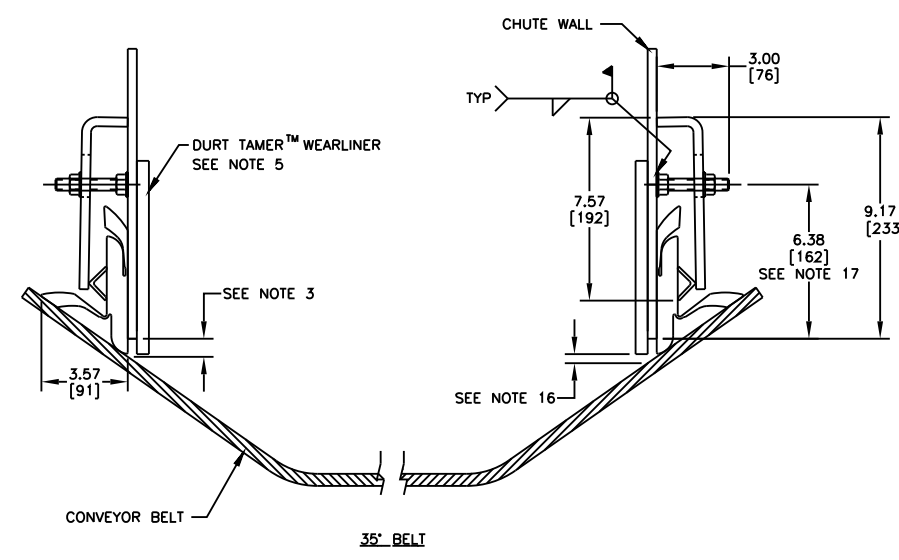
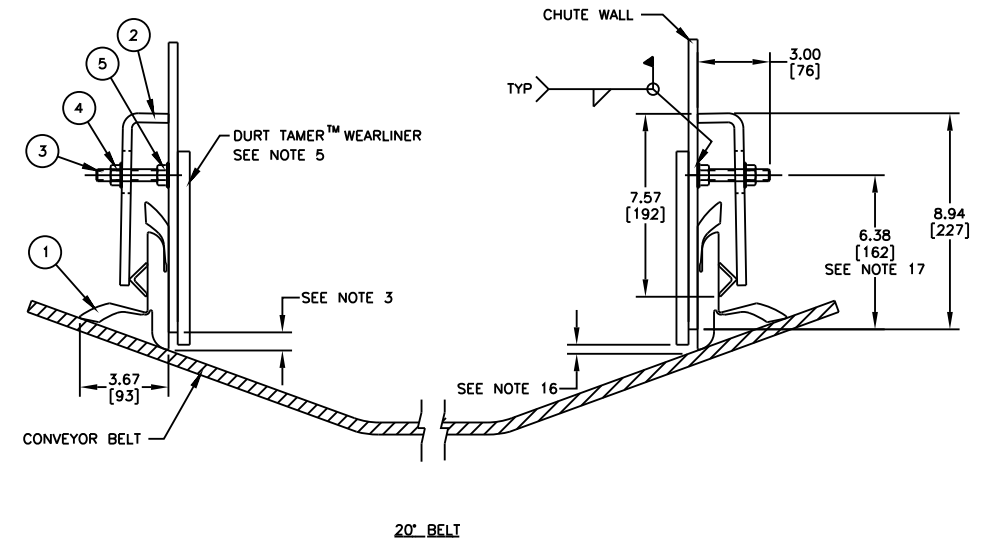
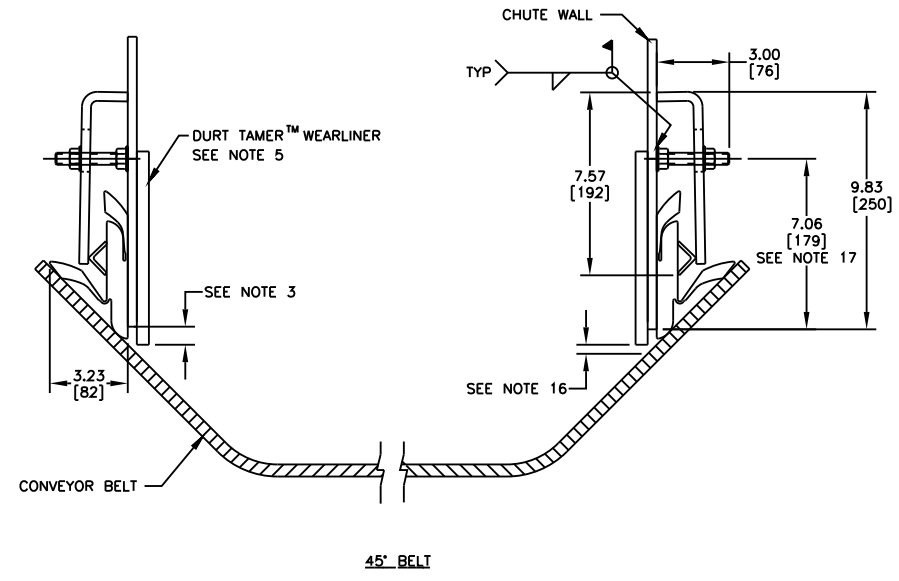

- NOTES:**
- 1) ALL DIMENSIONS ARE GIVEN IN INCHES (MM).
 - 2) ALL DIMENSIONS ARE FOR REFERENCE ONLY.
 - 3) MARTIN ENGINEERING RECOMMENDS CHUTE WALL TO BE WITHIN .75 (19) OF BELT.
 - 4) A MIN. OF 8.00 (203) VERTICAL AND 4.00 (102) HORIZONTAL CLEARANCE REQUIRED TO INSTALL APRON SEAL™ & ANGLE CLAMPS.
 - 5) TO PROVIDE AN EFFECTIVE SEAL, DURT TAMER™ WEARLINERS (STRAIGHT OR DEFLECTOR) ARE RECOMMENDED TO PREVENT THE MAIN LOAD FROM CONTACTING THE APRON SEAL™ (STRAIGHT WEARLINER SHOWN).
 - 6) IF DURT TAMER™ WEARLINERS ARE BOLTED TO CHUTE WALL, APRON SEAL™ AND ANGLE CLAMPS ARE TO BE MOUNTED IN A MANNER AS TO ALLOW EASY ACCESS TO BOLTS.
 - 7) APRON SEAL™ IS DESIGNED AS A DUST SEAL ONLY. IT IS NOT TO BE USED AS A MATERIAL HOLDBACK OR LOAD CARRYING SURFACE.
 - 8) BELT MUST NOT LIFT OFF IDLERS DURING START-UP OR WHILE BELT IS IN OPERATION.
 - 9) BELT MUST TRACK PROPERLY TO PREVENT IT FROM RUNNING BEHIND APRON SEAL™.
 - 10) CONSULT MARTIN ENGINEERING FOR INSTALLATIONS WITH UNUSUAL OR SEVERE CONDITIONS, I.E.: CONCAVE/CONVEX CURVES, EXTREME SIDE PRESSURE, UNUSUALLY FAST OR SLOW MOVING BELTS, TEMPERATURE EXTREMES, ETC.
 - 11) APRON SEAL™ AND DURT TAMER™ WEARLINER SHOULD BEGIN AT LEAST 12.00 (305) BEFORE INLET SIDE OF CHUTE WALL.
 - 12) CONTACT MARTIN ENGINEERING PRIOR TO MOUNTING THESE PRODUCTS IN ANY WAY OTHER THAN WHAT IS DEPICTED ON THIS DRAWING OR IN OPERATOR'S MANUAL (M3248).
 - 13) ANGLE CLAMP WELDMENT (ITEM 2) IS TO BE FULLY TIGHTENED AGAINST CHUTE WALL.
 - 14) ANGLE CLAMP WELDMENT MUST HAVE FIRM BACKING TO ENSURE PROPER CLAMP FORCE.
 - 15) REFER TO OPERATOR'S MANUAL M3248 DURING INSTALLATION. THIS DRAWING NOT TO BE USED IN PLACE OF OPERATOR'S MANUAL.
 - 16) .38 (10) MAX. IN IMPACT AREA, TAPERING TO .75 (19) AT EXIT AREA.
 - 17) FOR FLAT TO 35° BELTS USE PRE-FAB CHUTE WALL P/N 33564-35. FOR 45° BELTS USE P/N 33564-45.

INSTALLATION INSTRUCTIONS

- STEP 1: SCRIBE A LINE PARALLEL TO BELT SURFACE 6.38 (162) ABOVE BELT. (NOTE: 45° BELT USE 7.06 (180))
- STEP 2: ALONG THIS LINE, MAKE FIRST MARK 5.88 (150) FROM END OF CHUTE WALL AND MARK EVERY 12.00 (305).
- STEP 3: ON THESE MARKED CENTERS, WELD 1/2-13NC x 3 STUDS. WHEN WELDING STUDS, MAKE SURE THAT THEY ARE WELDED PERPENDICULAR TO THE CHUTE WALL TO ENSURE EVEN CLAMP CONTACT.
- STEP 4: PLACE APRON SEAL™ AGAINST CHUTE WALL, MAKING SURE IT IS IN CONTINUOUS CONTACT WITH BELT. PLACE ANGLE CLAMP WELDMENT OVER PREVIOUSLY WELDED STUDS.
- STEP 5: PUSH ANGLE CLAMP WELDMENT TIGHT AGAINST APRON SEAL™ AND INSTALL LOCKING NUTS. TIGHTEN NUTS TO 40 FT/LBS.

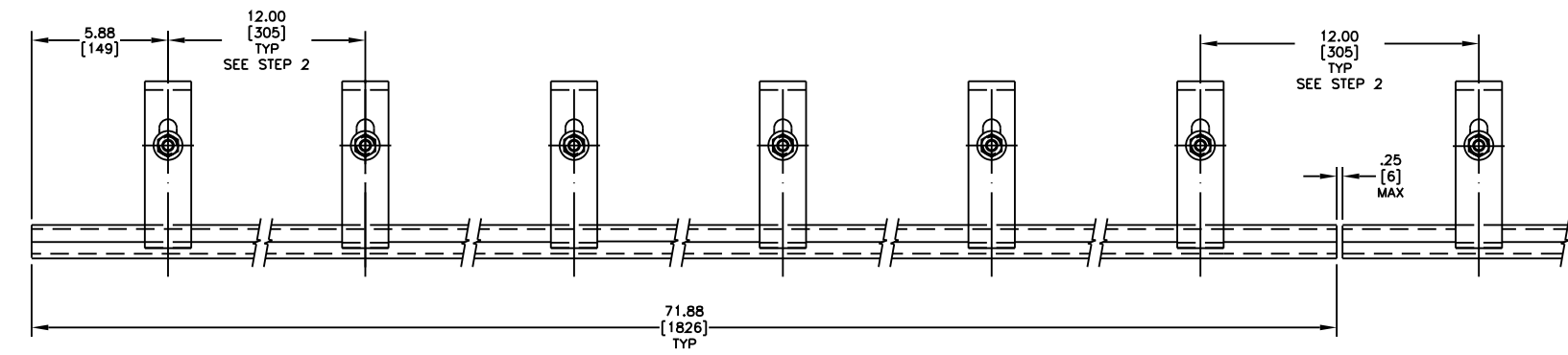

ANGLE CLAMP DETAIL

© Copyright 2009 Martin Engineering. All rights reserved. Covered by U.S. and foreign patents pending and issued. ® and ™ indicate trademarks of Martin Engineering.

MARTIN ENGINEERING NEPONSET ILLINOIS USA

TITLE: MARTIN® HEAVY DUTY DOUBLE APRON SEAL™ W/STD ANGLE CLAMP INSTALLATION DRAWING

NO. DESCRIPTION ECN DATE BY SALES DRAWING MDO773 S50065

DRAWN JAP DATE 05/18/09 CHECKED DATE 05/29/09 APPROVED DATE 05/29/09 SCALE 1/4

