

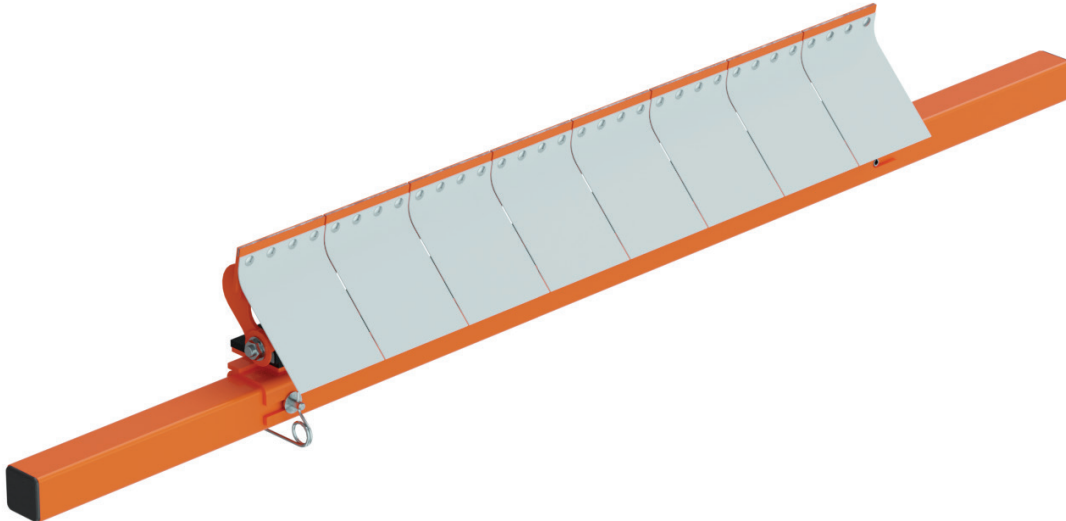

Martin[®]
SQC2S[™] Secondary Cleaner
with Orion Blades

[Go to Martin[®] SQC2S[™] Cleaner web page](#)



Operator's Manual
M4198

Important

MARTIN ENGINEERING HEREBY DISCLAIMS ANY LIABILITY FOR: DAMAGE DUE TO CONTAMINATION OF THE MATERIAL; USER'S FAILURE TO INSPECT, MAINTAIN AND TAKE REASONABLE CARE OF THE EQUIPMENT; INJURIES OR DAMAGE RESULTING FROM USE OR APPLICATION OF THIS PRODUCT CONTRARY TO INSTRUCTIONS AND SPECIFICATIONS CONTAINED HEREIN. MARTIN ENGINEERING'S LIABILITY SHALL BE LIMITED TO REPAIR OR REPLACEMENT OF EQUIPMENT SHOWN TO BE DEFECTIVE.

Observe all safety rules given herein along with owner and Government standards and regulations. Know and understand lockout/tagout procedures as defined by American National Standards Institute (ANSI) z244.1-1982, *American National Standard for Personnel Protection - Lockout/Tagout of Energy Sources - Minimum Safety Requirements* and Occupational Safety and Health Administration (OSHA) Federal Register, Part IV, 29 CFR Part 1910, *Control of Hazardous Energy Source (Lockout/Tagout); Final Rule*.

The following symbols may be used in this manual:



Danger: Immediate hazards that will result in severe personal injury or death.



Warning: Hazards or unsafe practices that could result in personal injury.



Caution: Hazards or unsafe practices that could result in product or property damages.



Important: Instructions that must be followed to ensure proper installation/operation of equipment.



Note: General statements to assist the reader.

Table of Contents

Section	Page
List of Figures and Tables.....	ii
Introduction.....	1
General.....	1
Installations without chutework.....	1
Belt cleaner inspection access.....	1
References.....	1
Safety.....	2
Before Installing Belt Cleaner.....	3
Installing Belt Cleaner Assembly.....	4
Marking chute cutouts.....	5
Removing blade.....	6
Installing tensioner.....	6
Installing blade.....	6
After Installing Belt Cleaner.....	7
Weekly Maintenance.....	8
Troubleshooting.....	9
Part Numbers.....	10

List of Figures

Figure	Title	Page
1	Mounting Locations.....	4
2	Tangent Point.....	5
3	Removing and Installing Blade Cartridge.....	6
4	Martin® SQC2S™ Cleaner Assembly with Orion Blades, P/N SQC2SX-XXXXXROXXX.....	11
5	Conveyor Products Warning Label, P/N 23395.....	15
6	Martin® SQC2S™ Tensioning Label, P/N SQC2-10002.....	15

List of Tables

Table	Title	Page
I-A	Martin® SQC2S™ Assembly Part Numbers and Quantities.....	12
I-B	Martin® SQC2S™ Extended Mainframe Assembly Part Numbers.....	13
I-C	Martin® SQC2S™ Mainframe Assembly Option Part Numbers.....	13
II	Martin® SQC2S™ Cleaner Assembly Blade & Deflector Chart.....	13
III-A	Martin® SQC2SH Tensioner Part Numbers and Belt Widths.....	14
III-B	Martin® SQC2SE Tensioner Part Numbers and Belt Widths.....	14
IV	Martin® SQC2S™ Cover Door Part Numbers.....	14

Introduction

General

To introduce product back into the product flow, a Pre-Cleaner is installed on the face of the head pulley. On a dual cleaner system, the Secondary Cleaner is installed immediately following the Pre-Cleaner to remove stubborn material left on the conveyor belt. If a Pre-Cleaner cannot be used because of space limitations, the Secondary Cleaner is installed alone. If the material handling process or product could be affected by contamination from the use of these belt cleaners, the user is responsible for taking the necessary steps to prevent contamination. Consult Martin Engineering or a representative for alternate belt cleaners or belt cleaner locations to use where contamination may be an issue.

Installations without chutework

These procedures were written for equipment that is being installed on enclosed pulley chutework. If the pulley is not enclosed, the equipment should be installed using the best available field resources and methods to ensure that the critical dimensions are followed for proper installation.

Belt cleaner inspection access

If the belt cleaner is installed on enclosed pulley chutework, a Martin® Inspection Door should be installed. Martin® Inspection Doors are available from Martin Engineering or a representative.

References

The following documents are referenced in this manual:

- American National Standards Institute (ANSI) z244.1-1982, *American National Standard for Personnel Protection - Lockout/Tagout of Energy Sources - Minimum Safety Requirements*, American National Standards Institute Inc., 1430 Broadway, New York, NY 10018.
- Federal Register, Volume 54, Number 169, Part IV, 29 CFR Part 1910, *Control of Hazardous Energy Source (Lockout/Tagout); Final Rule*, Department of Labor, Occupational Safety and Health Administration (OSHA), 32nd Floor, Room 3244, 230 South Dearborn Street, Chicago, IL 60604.
- Martin® SQC2S™ *Square Mainframe Tensioners Operator's Manual*, P/N M3815

Safety

All safety rules defined in the above documents and all owner/employer safety rules must be strictly followed when working on the belt cleaner.



⚠ DANGER

Do not touch or go near the conveyor belt or conveyor accessories when the belt is running. Your body or clothing can get caught and you can be pulled into the conveyor, resulting in severe injury or death.



⚠ DANGER

Before installing, servicing, or adjusting the belt cleaner, turn off and lock out/tag out all energy sources to the conveyor and conveyor accessories according to ANSI standards. Failure to do so could result in serious injury or death.



⚠ DANGER

If this equipment will be installed in an enclosed area, test the gas level or dust content before using a cutting torch or welding. Using a torch or welding in an area with gas or dust may cause an explosion resulting in serious injury or death.



⚠ WARNING

Before using a cutting torch or welding the chute wall, cover the conveyor belt with a fire retardant cover. Failure to do so can allow the belt to catch fire.

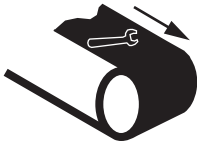

⚠ WARNING

Remove all tools from the installation area and conveyor belt before turning on the conveyor. Failure to do so can cause serious injury to personnel or damage to the belt and conveyor.



⚠ WARNING

Mainframe with blade can be heavy and may require two people to lift. Attempting to lift the belt cleaner without assistance could result in injury.

Before Installing Belt Cleaner

IMPORTANT

The delivery service is responsible for damage occurring in transit. Martin Engineering CANNOT enter claims for damages. Contact your transportation agent for more information.

1. Inspect shipping container for damage. Report damage to delivery service immediately and fill out delivery service's claim form. Keep any damaged goods subject to examination.
2. Remove belt cleaner assembly from shipping container.
3. If anything is missing contact Martin Engineering or a representative.



WARNING

Before installing equipment, turn off and lock out/ tag out all energy sources to the conveyor and conveyor accessories according to ANSI standards. Failure to do so could result in serious injury or death.

4. Turn off and lock out/tag out energy source according to ANSI standards (see "References").

DANGER

If this equipment will be installed in an enclosed area, test the gas level or dust content before using a cutting torch or welding. Using a torch or welding in an area with gas or dust may cause an explosion resulting in serious injury or death.

5. If using a cutting torch or welding, test atmosphere for gas level or dust content. Cover conveyor belt with fire retardant cover.



IMPORTANT

Center the belt cleaner blades to clean an area narrower than the conveyor belt width. This allows for side-to-side movement of the belt and prevents damage to the belt edge.

Installing Belt Cleaner Assembly

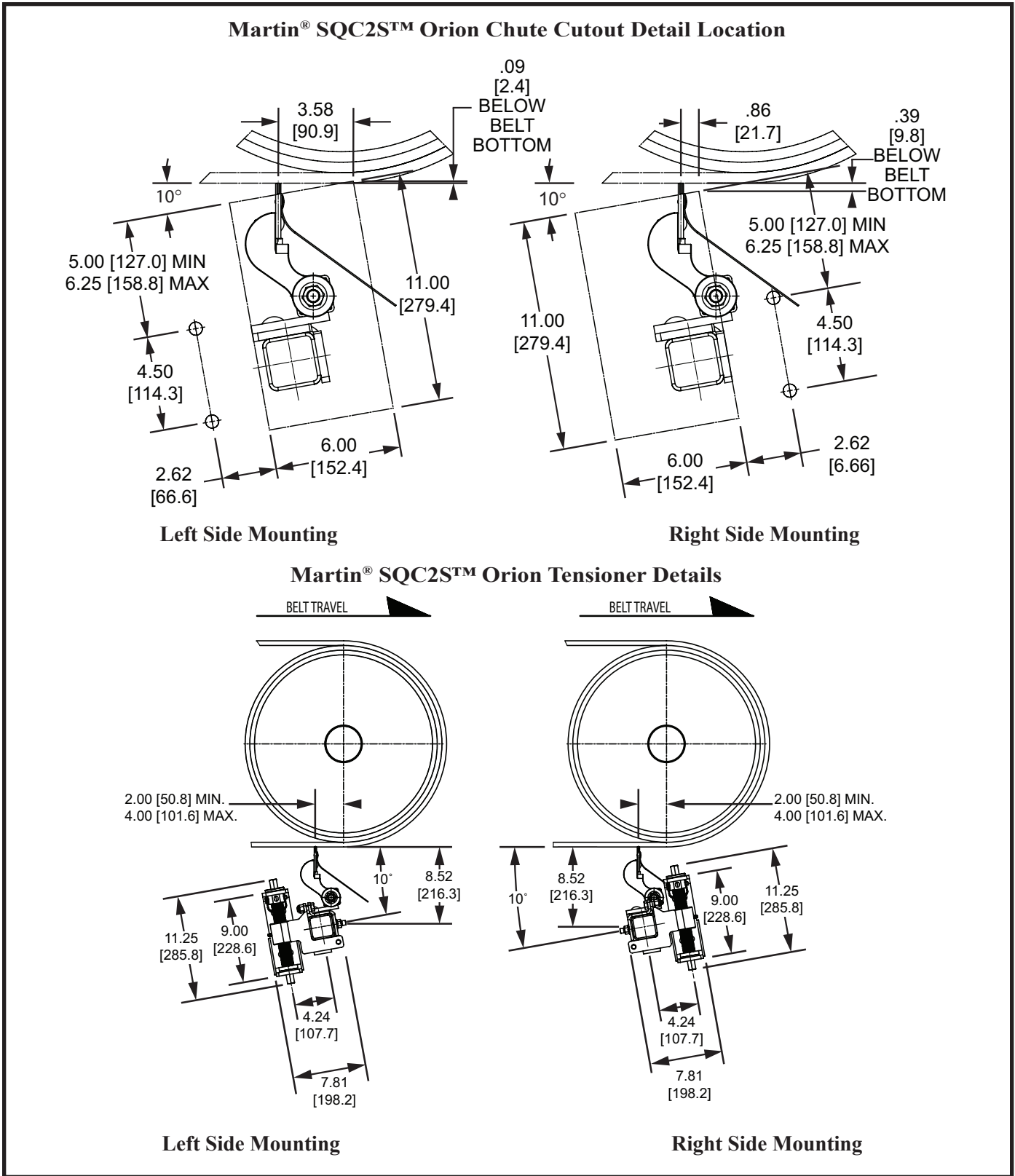

Figure 1. Mounting Locations

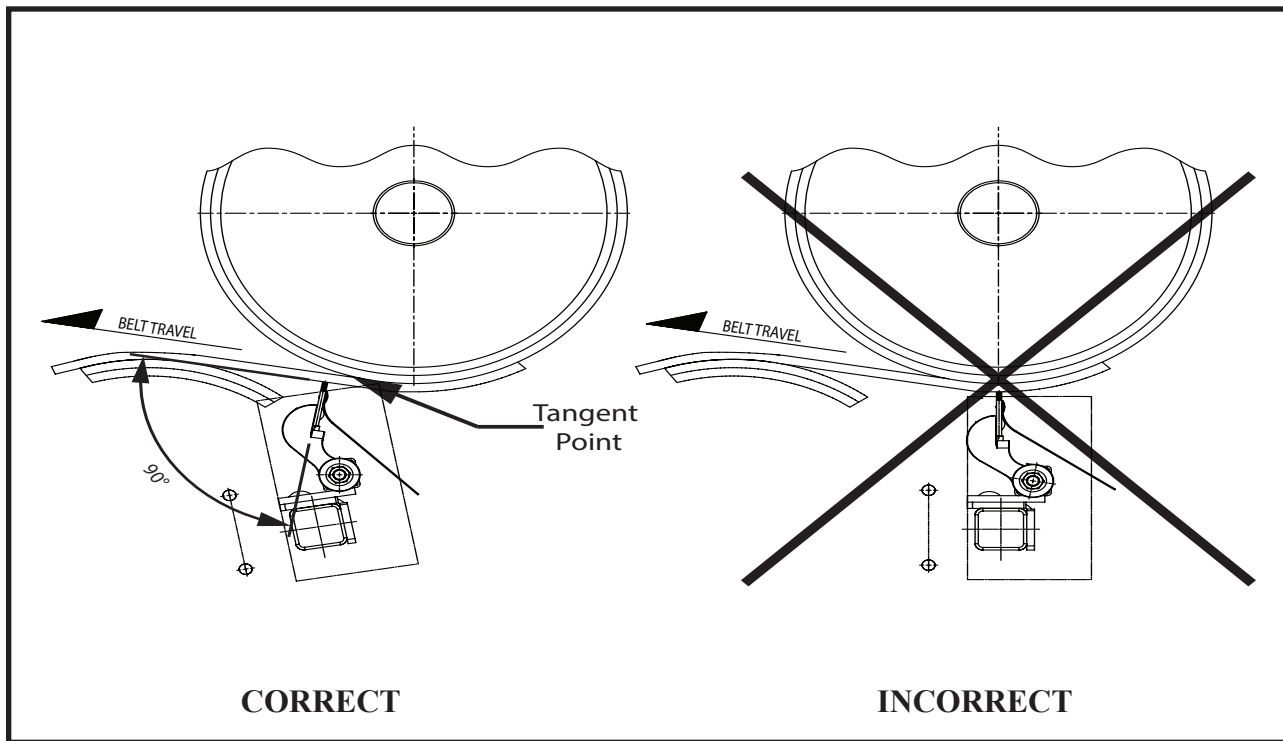

Figure 2. Tangent Point

IMPORTANT

Belt cleaner mounting location must be marked using a line perpendicular to the belt line at the tangent point (point where the belt leaves the head pulley), see Figure 2. **DO NOT** use the vertical centerline of the head pulley.

NOTE

Solid backing of the blade is essential to ensure proper operation and efficient cleaning. Install the cleaner adjacent to the head pulley or a flat pressure roller to obtain best cleaning results.

NOTE

For installation on enclosed head pulley chutework, draw all dimension lines on chute wall. In applications where head pulley is not enclosed, use the best available field resources and/or methods to ensure that these critical dimensions are followed for a proper installation.

Marking chute cutouts

1. Mark the chute cutout and mount hole locations as shown in Figure 1. Repeat on both sides of chute, ensuring cutouts are accurately aligned with each other.
2. At the selected mounting position, cut the cleaner access slots and drill the mount holes in each side of the chute. Dress and de-burr the holes and cutouts.

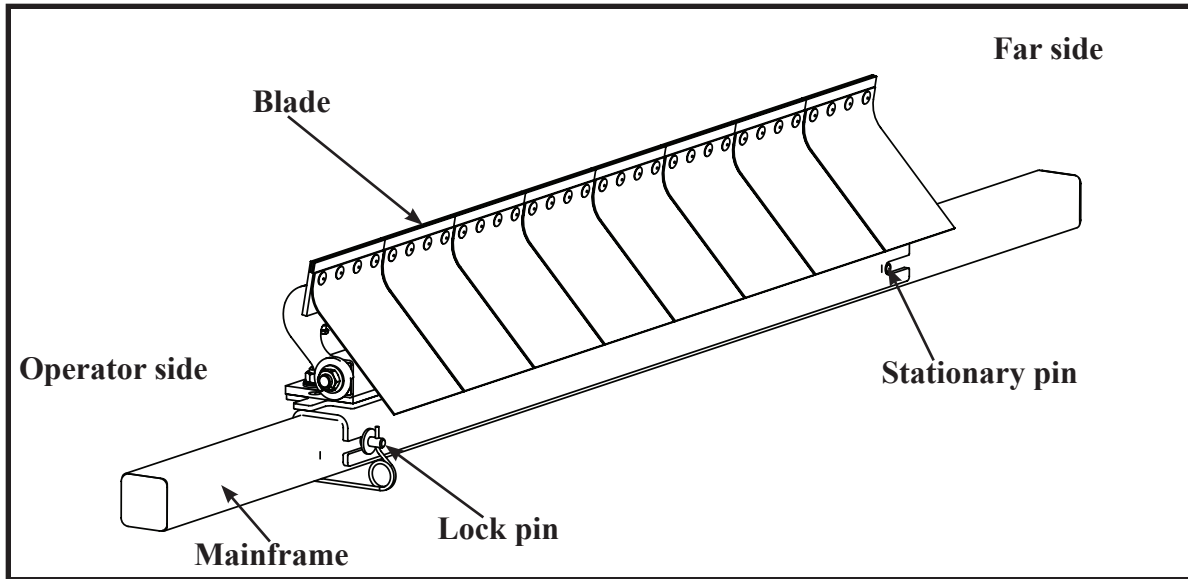

Figure 3. Removing and Installing Blade Cartridge

Removing blade

1. Remove lock pin from operator side of mainframe and blade.
2. Pull blade away from stationary pin on far side of mainframe and remove from mainframe. Make sure lock pin remains attached to mainframe.

Installing tensioner

1. Install tensioner according to *Martin® SQC2S™ Square Mainframe Tensioner Operator's Manual*, P/N M3815.
2. If using *Martin® Inspection Door*, install according to *Martin® Inspection Door Operator's Manual*, P/N M3891.

Installing blade

1. Slide blade cartridge onto mainframe with blade positioned as shown in Figure 1. Push far side end of blade against stationary pin until it locks.
2. Insert lock pin in mainframe and cartridge.
3. Make sure blades are centered on belt and mainframe is parallel to belt.
4. Tension belt cleaner according to *Martin® SQC2S™ Square Mainframe Tensioner Operator's Manual*, P/N M3815.

After Installing Belt Cleaner



1. Thoroughly wipe chute wall clean above tensioner.
2. Place Conveyor Products Warning Label (P/N 23395) on outside chute wall visible to belt cleaner operator.

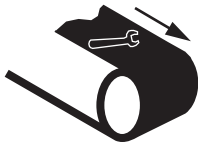

Failure to remove tools from installation area and conveyor belt before turning on energy source can cause serious injury to personnel and damage to belt.



Do not touch or go near conveyor belt or conveyor accessories when conveyor belt is running. Body or clothing can get caught and pull body into conveyor belt, causing severe injury or death.

3. Turn on conveyor belt for 1 hour, then turn off.



Before installing, servicing, or adjusting the belt cleaner/tensioner, turn off and lock out/tag out all energy sources to the conveyor and conveyor accessories according to ANSI standards. Failure to do so could result in serious injury or death.

4. Make sure all fasteners are tight. Tighten if necessary.
5. Make sure cleaner is not changing belt line. If it is, install belt support ahead of blade-to-belt contact point (Secondary Cleaner).
6. Inspect belt cleaner for the following:
 - Wear. (A small amount of “break-in” wear may be found. This will stop once blades wear to conveyor belt contour.)
 - Material buildup. (No material between blades and return side of conveyor belt should be found.)
7. If wear, material buildup, or some other problem exists, see “Troubleshooting.”

Weekly Maintenance

IMPORTANT

Read entire section before beginning work.

NOTE

Maintenance inspection should be performed no less than weekly. Some applications may require more frequent maintenance inspections.

⚠ DANGER

Before installing, servicing, or adjusting the belt cleaner/tensioner, turn off and lock out/tag out all energy sources to the conveyor and conveyor accessories according to ANSI standards. Failure to do so could result in serious injury or death.



1. Remove any material from belt cleaner.
2. Make sure all fasteners are tight. Tighten if necessary.
3. Check tension on cleaner. Re-tension if necessary.
4. Wipe all labels clean. If labels are not readable, contact Martin Engineering or a representative for replacements.
5. Check blades for excessive wear. Replace if necessary.
6. Remove equipment from service if there is any indication it is not functioning properly. Call Martin Engineering or a representative for assistance. Do NOT return equipment to operation until the cause of the problem has been identified and corrected.

⚠ WARNING

Failure to remove tools from installation area and conveyor belt before turning on energy source can cause serious injury to personnel and damage to belt.

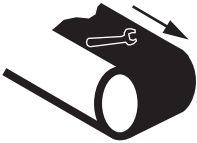

7. Remove all tools from maintenance area.

⚠ DANGER

Do not touch or go near conveyor belt or conveyor accessories when conveyor belt is running. Body or clothing can get caught and pull body into conveyor belt, causing severe injury or death.



8. Start conveyor belt.

Troubleshooting

Symptom	Corrective Action
Insufficient cleaning and carryback.	<ul style="list-style-type: none"> • Tension of cleaner on belt is set too low or too high. Increase or decrease tensioner setting. • Blades are worn. Check blades and replace if necessary.
Noise or vibration.	Tension is not sufficient or is set too high. Correct tension as necessary. If this does not correct problem, blade urethane may not match application. Contact Martin Engineering or representative.
High blade wear rate.	Tension of cleaner on belt is set too high. Reduce tensioner setting.
Unusual wear or damage to blades.	Check belt splice(s) and repair as necessary.
Bent or broken mainframe or support frame due to blade slipping through.	If blades are worn to or past the wear line, replace blades. If blades are not worn, check mainframe location.
Corrosion or chemical degradation.	Blade urethane may not match application. Contact Martin Engineering or representative.

NOTE

Conveyor equipment such as conveyor belt cleaners are subject to a wide variety of bulk materials characteristics and often have to perform under extreme operating or environmental conditions. It is not possible to predict all circumstances that may require troubleshooting. Contact Martin Engineering or a representative if you are experiencing problems other than those listed in the “Troubleshooting” chart above. Do not return the equipment to operation until the problem has been identified and corrected.

Installation checklist

If after taking the corrective actions suggested under “Troubleshooting” you are still experiencing problems, check for the following:

Installation Checklist
Pre-Cleaner mainframe is proper distance from belt surface on both ends of mainframe.
Pre-Cleaner blade tip is at or below horizontal center line of pulley and does not lie in path of material flow.
Secondary Cleaner blade tip is 2 in. (51 mm) past vertical center line of pulley.
Secondary Cleaner is not changing belt line.
Blades are centered on belt.

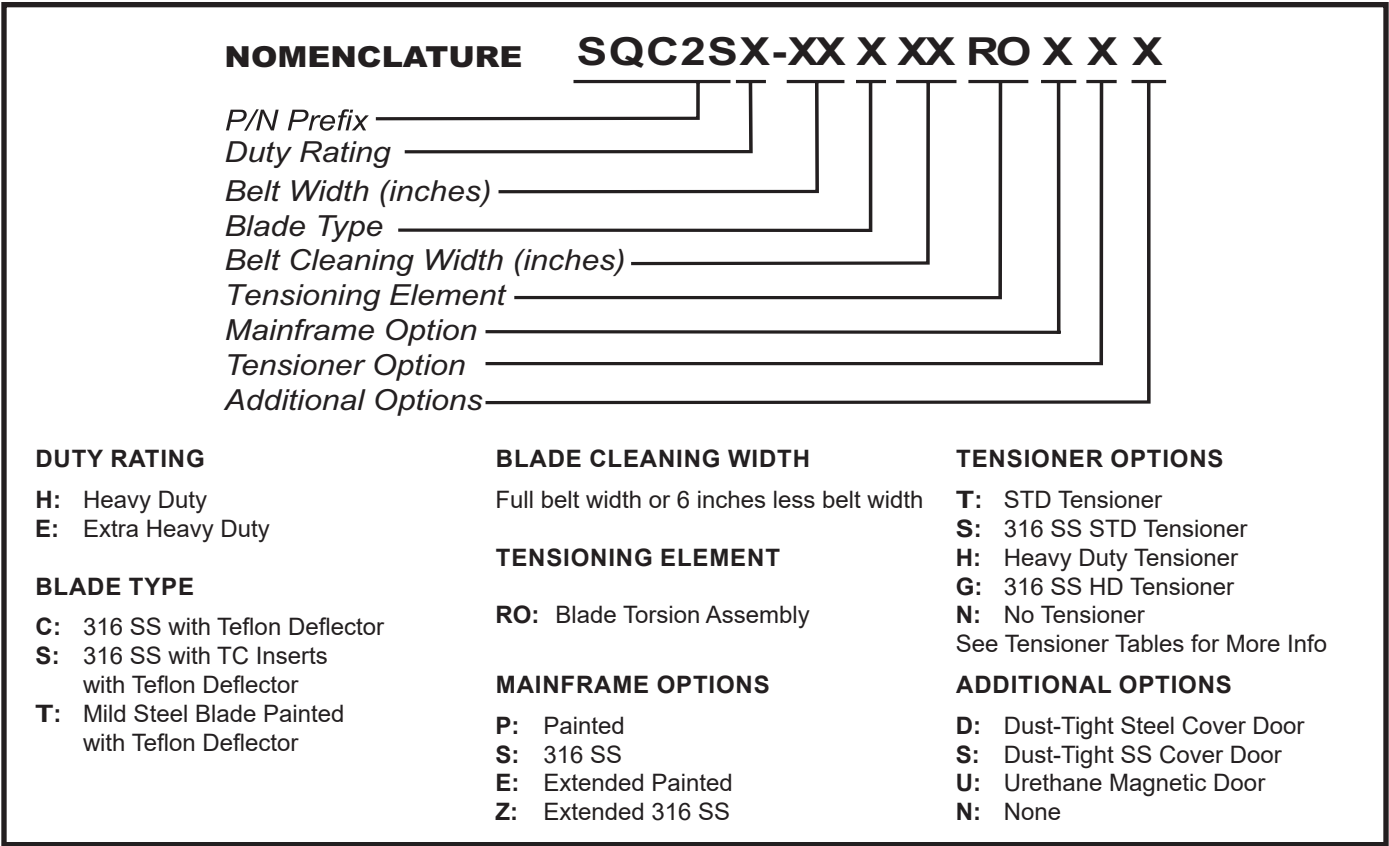

Martin® SQC2S™ Heavy Duty Orion Assembly

P/N SQC2SH-XXXXXROXXX. See Figure 4. Includes blade cartridge, mainframe and tensioners.

Martin® SQC2S™ Extra Heavy Duty Orion Assembly

P/N SQC2SE-XXXXXROXXX. See Figure 4. Includes blade cartridge, mainframe and tensioners.

Martin® Tensioners

Martin® SQC2S™ Square Mainframe Tensioners: P/N 38664.
 Martin® SQC2S™ Square Mainframe Tensioners: P/N 38664-SS.
 Martin® SQC2S™ Square Mainframe Tensioners HD: P/N 38664-HD.
 Martin® SQC2S™ Square Mainframe Tensioners HD: P/N 38664-HDS.

Martin® SQC2S™ Blade Cartridges

P/N SQC2SC-ORCW-XXXXT. Includes replacement blades.
 P/N SQC2SC-ORCW-XXXXS. Includes replacement blades.
 P/N SQC2SC-ORCW-XXXXF. Includes replacement blades.

Martin® SQC2S™ Door Options

P/N 38014-SQCS. Used to keep debris out while also allowing for inspection and maintenance.
 P/N 38014-SQCSS. Used to keep debris out while also allowing for inspection and maintenance with a corrosion resistant material.
 P/N 38014U-SQCS. Used to keep debris out while also allowing for inspection and maintenance with a magnetic door of urethane.

Miscellaneous

Martin® Heavy-Duty Hanger Mount Assembly:
 P/N 34233-HD. Used to mount Martin® SQC2S™ Tensioners onto stringer instead of onto chute wall.
Martin® Heavy-Duty Hanger Mount Assembly - Stainless Steel:
 P/N 34223-HDS. Used to mount Martin® SQC2S™ Tensioners onto stringer instead of onto chute wall while being corrosion resistant.

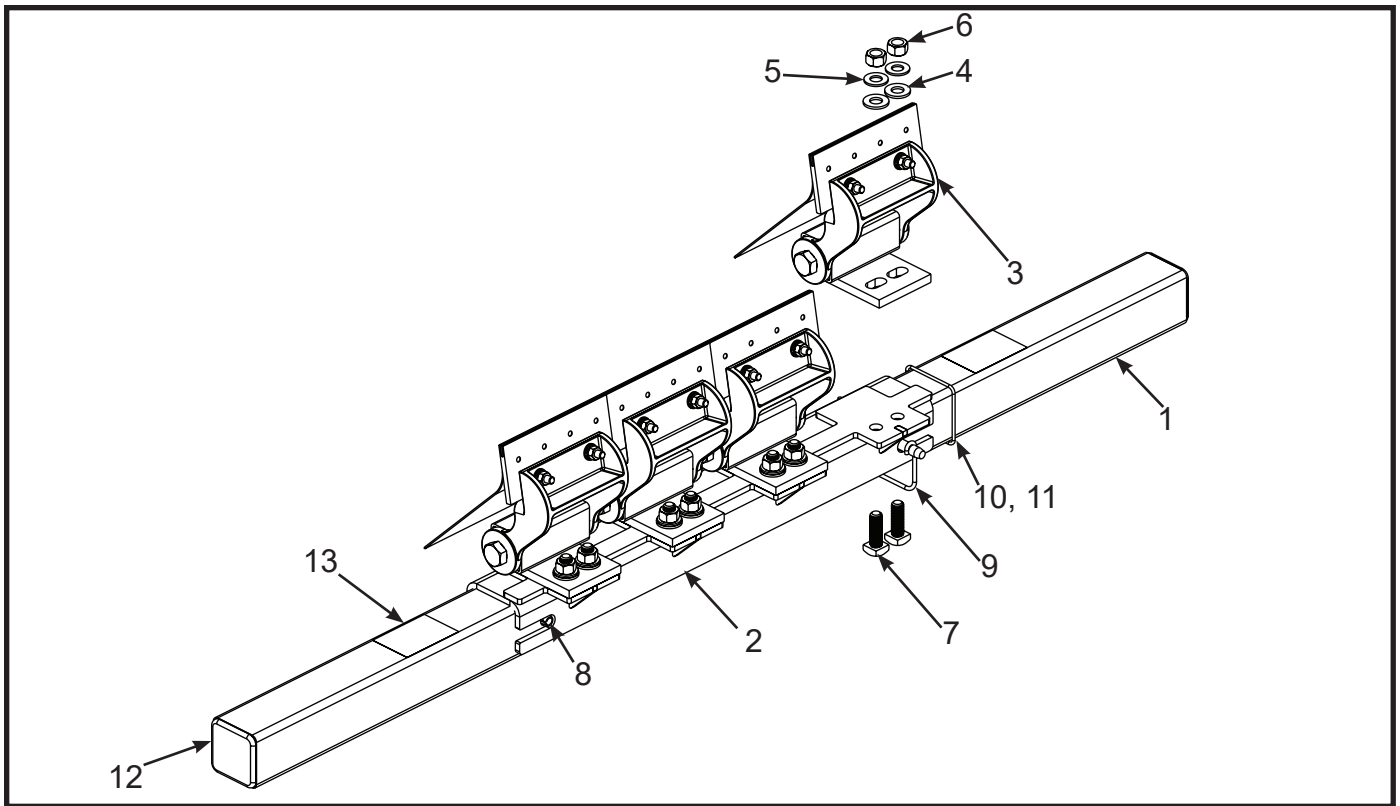

Figure 4. Martin® SQC2S™ Cleaner Assembly, P/N SQC2SX-XXXXXROXXX*

Item	Description	Part Number	Qty
1	Mainframe	Table I	1
2	Blade Cartridge	Table I	1
3	Blade Assembly	Table II	Table I
4	Washer Flat 1/2	Table I	Table I
5	Washer Compression	Table I	Table I
6	Nut Hex 1/2 – 13NC	Table I	Table I
7	Screw 1/2 – 13 X 1 – 1/2	Table I	Table I
8	Pin Slotted Spring 1/2 X 3 ZP	33840	1
9	Pin Snap Lock 7/16	33841	1
10	Rope Wire 1/8 SS	100107	2
11	Cable Clip for 1/8 Dia. Cable	23481	2
12	Plug for 2.50 SQ Tube	34896-02	2
13	Label Martin Products	38048	2
14 (NS)	Label Conveyor Product Warning	23395	2
15 (NS)	Martin® SQC2S® Tensioner	Table III	1
16 (NS)	Split Dust-Tight Door Assembly	Table IV	1
17 (NS)	Manual Operators	M4198	1

* First X indicates duty rating.

Table I-A. Martin® SQC2S™ Cleaner Assembly Part Numbers and Quantities*

Part No.	P/N Item 1	P/N Item 2	QTY. Item 3	QTY. Item 4-7
SQC2SX-18X12ROXXX	38657-18X	SQC2SC-ORCW-1812X	2	4
SQC2SX-18X18ROXXX	38657-18X	SQC2SC-ORCW-1818X	3	6
SQC2SX-24X18ROXXX	38657-24X	SQC2SC-ORCW-2418X	3	6
SQC2SX-24X24ROXXX	38657-24X	SQC2SC-ORCW-2424X	4	8
SQC2SX-30X24ROXXX	38657-30X	SQC2SC-ORCW-2424X	4	8
SQC2SX-30X30ROXXX	38657-30X	SQC2SC-ORCW-3030X	5	10
SQC2SX-36X30ROXXX	38657-36X	SQC2SC-ORCW-3630X	5	10
SQC2SX-36X36ROXXX	38657-36X	SQC2SC-ORCW-3636X	6	12
SQC2SX-42X36ROXXX	38657-42X	SQC2SC-ORCW-4236X	6	12
SQC2SX-42X42ROXXX	38657-42X	SQC2SC-ORCW-4242X	7	14
SQC2SX-48X42ROXXX	38657-48X	SQC2SC-ORCW-4842X	7	14
SQC2SX-48X48ROXXX	38657-48X	SQC2SC-ORCW-4848X	8	16
SQC2SX-54X48ROXXX	38657-54X	SQC2SC-ORCW-5448X	8	16
SQC2SX-54X54ROXXX	38657-54X	SQC2SC-ORCW-5454X	9	18
SQC2SX-60X54ROXXX	38657-60X	SQC2SC-ORCW-6054X	9	18
SQC2SX-60X60ROXXX	38657-60X	SQC2SC-ORCW-6060X	10	20
SQC2SX-66X60ROXXX	38657-66X	SQC2SC-ORCW-6660X	10	20
SQC2SX-66X66ROXXX	38657-66X	SQC2SC-ORCW-6666X	11	22
SQC2SX-72X66ROXXX	38657-72X	SQC2SC-ORCW-7266X	11	22
SQC2SX-72X72ROXXX	38657-72X	SQC2SC-ORCW-7272X	12	24
SQC2SX-78X72ROXXX	38657-78X	SQC2SC-ORCW-7872X	12	24
SQC2SX-78X78ROXXX	38657-78X	SQC2SC-ORCW-7878X	13	26
SQC2SX-84X78ROXXX	38657-84X	SQC2SC-ORCW-8478X	13	26
SQC2SX-84X84ROXXX	38657-84X	SQC2SC-ORCW-8484X	14	28
SQC2SX-90X84ROXXX	38657-90X	SQC2SC-ORCW-9084X	14	28
SQC2SX-90X90ROXXX	38657-90X	SQC2SC-ORCW-9090X	15	30
SQC2SX-96X90ROXXX	38657-96X	SQC2SC-ORCW-9690X	15	30
SQC2SX-96X96ROXXX	38657-96X	SQC2SC-ORCW-9696X	16	32

* First X indicates duty rating.

Table I-B. Martin® SQC2S™ Extended Mainframe Assembly Part Numbers*

Part No.	P/N Item 1	Part No.	P/N Item 1	Part No.	P/N Item 1
SQC2SX-18X12ROEXX	38657-18EX	SQC2SX-42X42ROEXX	38657-42EX	SQC2SX-72X72ROEXX	38657-72EX
SQC2SX-18X18ROEXX	38657-18EX	SQC2SX-48X42ROEXX	38657-48EX	SQC2SX-78X72ROEXX	38657-78EX
SQC2SX-24X18ROEXX	38657-24EX	SQC2SX-48X48ROEXX	38657-48EX	SQC2SX-78X78ROEXX	38657-78EX
SQC2SX-24X24ROEXX	38657-24EX	SQC2SX-54X48ROEXX	38657-54EX	SQC2SX-84X78ROEXX	38657-84EX
SQC2SX-30X24ROEXX	38657-30EX	SQC2SX-54X54ROEXX	38657-54EX	SQC2SX-84X84ROEXX	38657-84EX
SQC2SX-30X30ROEXX	38657-30EX	SQC2SX-60X54ROEXX	38657-60EX	SQC2SX-90X84ROEXX	38657-90EX
SQC2SX-36X30ROEXX	38657-36EX	SQC2SX-60X60ROEXX	38657-60EX	SQC2SX-90X90ROEXX	38657-90EX
SQC2SX-36X36ROEXX	38657-36EX	SQC2SX-66X60ROEXX	38657-66EX	SQC2SX-96X90ROEXX	38657-96EX
SQC2SX-42X36ROEXX	38657-42EX	SQC2SX-66X66ROEXX	38657-66EX	SQC2SX-96X96ROEXX	38657-96EX
		SQC2SX-72X66ROEXX	38657-72EX		

Table I-C. Martin® SQC2S™ Mainframe Assembly Option Part Numbers*

Part No.	P/N Item 1	P/N Item 2	P/N Item 4	P/N Item 5	P/N Item 6	P/N Item 7
SQC2SX-XXXXX-ROEXX	38657-XX	SQC2SC-ORCW-XXXXT	31010	11750	11771	SUS10194
SQC2SX-XXXXX-ROEXX	38657-XXE					
SQC2SX-XXXXX-ROEXX	38657-XXS	SQC2SC-ORCW-XXXXF	17152	24310	17151	22766
SQC2SX-XXXXX-ROEXX	38657-XXES					

Table II. Martin® SQC2S™ Cleaner Assembly Blade & Deflector Chart*

Part No.	P/N Item 3	Color	Blade & Deflector Material
SQC2SX-XXCXXROXXX	OR-52000-6C	-	316 SS Blade with Teflon Deflector
SQC2SX-XXSXXROXXX	OR-52000-6S	-	316 SS Blade with TC Inserts with Teflon Deflector
SQC2SX-XXTXXROXXX	OR-52000-6T	Orange	Mild Steel Blade with TC Inserts Painted with Teflon Deflector

* First X indicates duty rating.

**Table III-A. Martin® SQC2SH
Optional Tensioner Part Numbers and Belt Widths**

Tensioner	Part Number	Belt Width Range	P/N Item 15
Standard Tensioner	SQC2SH-XXXXXROXTX	18" - 48" (450 - 1,200)	38664
316 SS Standard Tensioner	SQC2SH-XXXXXROXSX	18" - 48" (450 - 1,200)	38664-SS
Heavy Duty Tensioner	SQC2SH-XXXXXROXHx	54" - 96" (1350 - 2,400)	38664-HD
316 SS Heavy Duty Tensioner	SQC2SH-XXXXXROXGX	54" - 96" (1350 - 2,400)	38664-HDS

**Table III-B. Martin® SQC2SE
Optional Tensioner Part Numbers and Belt Widths**

Tensioner	Part Number	Belt Width Range	P/N Item 15
Heavy Duty Tensioner	SQC2SE-XXXXXROXHx	54" - 96" (1350 - 2,400)	38664-HD
316 SS Heavy Duty Tensioner	SQC2SE-XXXXXROXGX	54" - 96" (1350 - 2,400)	38664-HDS

**Table IV. Martin® SQC2S™
Optional Cover Door Part Numbers***

Part Number	P/N Item 16
SQC2SX-XXXXXROXXD	38014-SQCS
SQC2SX-XXXXXROXXS	38014-SQCSS
SQC2SX-XXXXXROXXU	38014U-SQCS

* First X indicates duty rating.

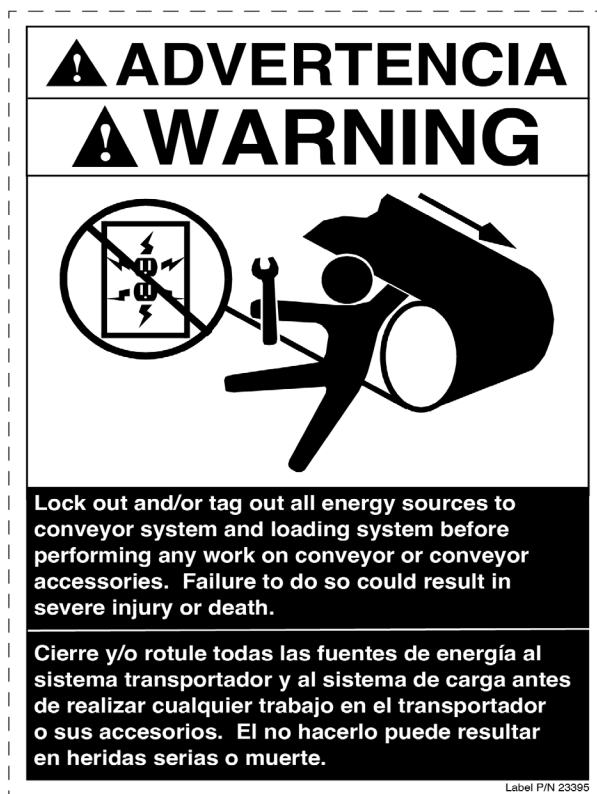

Figure 5. Conveyor Products Warning Label, P/N 23395

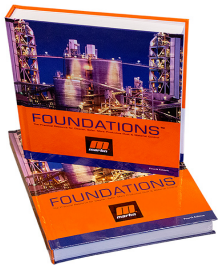

Figure 6. Martin® SQC2S™ Tensioning Label, P/N SQC2-10002

Any product, process, or technology described here may be the subject of intellectual property rights reserved by Martin Engineering Company. Trademarks or service marks designated with the ® symbol are registered with the U.S. Patent and Trademark Office and may be proprietary in one or more countries or regions. Other trademarks and service marks belonging to Martin Engineering Company in the United States and/or other countries or regions may be designated with the “TM” and “SM” symbols. Brands, trademarks, and names of other parties, who may or may not be affiliated with, connected to, or endorsed by Martin Engineering Company, are identified wherever possible.

Additional information regarding Martin Engineering Company’s intellectual property can be obtained at www.martin-eng.com/trademarks.

Problem Solved™ ***GUARANTEED!***



For nearly 30 years, Martin Engineering's Foundations™ Books have taught industry personnel to operate and maintain clean and safe belt conveyors. The Foundations™ Book, fourth edition, focuses on improving belt conveyors by controlling fugitive material. "The Practical Resource for Total Dust and Material Control," is a 576-page hard cover volume that provides information of value to industries where the efficient handling of bulk materials is a key to productivity and profitability.

Expanding upon the book, our Foundations™ Training Program addresses the design and development of more productive belt conveyors, and is offered in three customizable seminars. Attendees gain a better understanding of conveyor safety and performance, helping to justify upgrade investments and increase profitability.



Martin Engineering USA

One Martin Place
Neponset, IL 61345-9766 USA
800 544 2947 or 309 852 2384
Fax 800 814 1553
www.martin-eng.com

**COMPANY WITH
QUALITY SYSTEM
CERTIFIED BY DNV GL
= ISO 9001 =**