

martin®

Martin® ***Torsion***
VPlow Plus

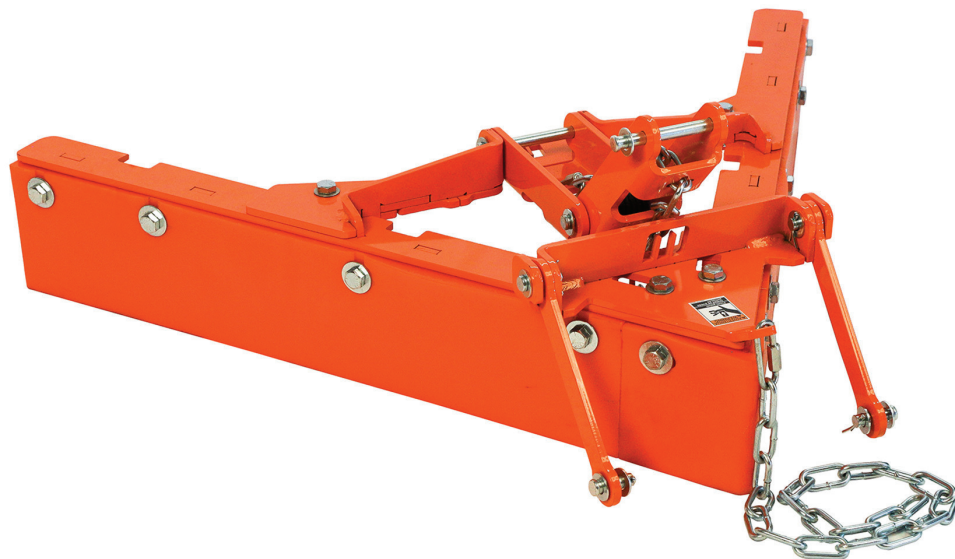

Operator's Manual
M4083

Important

MARTIN ENGINEERING HEREBY DISCLAIMS ANY LIABILITY FOR: DAMAGE DUE TO CONTAMINATION OF THE MATERIAL; USER'S FAILURE TO INSPECT, MAINTAIN AND TAKE REASONABLE CARE OF THE EQUIPMENT; INJURIES OR DAMAGE RESULTING FROM USE OR APPLICATION OF THIS PRODUCT CONTRARY TO INSTRUCTIONS AND SPECIFICATIONS CONTAINED HEREIN. MARTIN ENGINEERING'S LIABILITY SHALL BE LIMITED TO REPAIR OR REPLACEMENT OF EQUIPMENT SHOWN TO BE DEFECTIVE.

Observe all safety rules given herein along with owner and Government standards and regulations. Know and understand lockout/tagout procedures as defined by American National Standards Institute (ANSI) z244.1-1982, *American National Standard for Personnel Protection - Lockout/Tagout of Energy Sources - Minimum Safety Requirements* and Occupational Safety and Health Administration (OSHA) Federal Register, Part IV, 29 CFR Part 1910, *Control of Hazardous Energy Source (Lockout/Tagout); Final Rule*.

The following symbols may be used in this manual:



Danger: Immediate hazards that will result in severe personal injury or death.



Warning: Hazards or unsafe practices that could result in personal injury.



Caution: Hazards or unsafe practices that could result in product or property damages.



Important: Instructions that must be followed to ensure proper installation/operation of equipment.



Note: General statements to assist the reader.

Table of Contents

Section	Page
List of Figures	ii
List of Tables	ii
Introduction	1
General	1
References	1
Safety	1
Materials required	1
Before Installing V-Plow	2
Installing V-Plow	3
Installing without adapter plate	5
Installing with adapter plate	6
Installing V-Plow	7
After Installing V-Plow	10
Monthly Maintenance	11
Part Numbers	12

List of Figures

Figure	Title	Page
1	Assembling V-Plow	3
2	Assembling Hanger Bars	3
3	Locating VPlow on Belt	4
4	Installation without Adapter Plates.....	5
5	Installation with Adapter Plates	6
6	Installing V-Plow on Hanger Bars	7
7	Torsion Clamp Position.....	7
8	Installing Blade.....	8
9	Installing Restraining Chain	9
10	Martin® Torsion VPlow Plus Assembly, P/N CPVTASXXXXXCXX.....	13
11	Conveyor Products Warning Label, P/N 23395	18
12	Flying Objects Warning Label, P/N 38227.....	19

List of Tables

Table	Title	Page
I	Martin® Torsion VPlow Plus Specifications.....	1
II	Martin® Torsion VPlow Plus Item Part Numbers	15
III	Martin® Torsion VPlow Plus Urethane Blade Color	16
IV	Martin® Torsion VPlow Plus Hanger Arms	16
V	Martin® Torsion VPlow Plus Torsion Arm Part Numbers	16
VI	Martin® Torsion VPlow Plus Quantities.....	16
VII	Martin® Torsion VPlow Plus Blade Part Numbers and Quantities.....	17

Introduction

General

The Martin® Torsion VPlow Plus floats on the inside surface of a conveyor belt to effectively remove stray material in light- to moderate-duty applications. The self-adjusting design provides effective cleaning in all states of blade wear.

The Martin® Torsion VPlow Plus fits belts from 18 to 120 in. (400 to 3000 mm) wide. Specifications are shown in Table I.

Table I. Martin® Torsion VPlow Plus Specifications

Cleaning Edge Material	80-Durometer Rubber
	90-Durometer Urethane
Blade Dimensions	1 x 4 in. (25 x 102 mm)
Operating Temperature	-20 to 160°F (-29 to 71°C)

References

The following documents are referenced in this manual:

- American National Standards Institute (ANSI) z244.1-1982, *American National Standard for Personnel Protection - Lockout/Tagout of Energy Sources - Minimum Safety Requirements*, American National Standards Institute, Inc., 1430 Broadway, New York, NY 10018.
- Federal Register, Volume 54, Number 169, Part IV, 29 CFR Part 1910, *Control of Hazardous Energy Source (Lockout/Tagout); Final Rule*, Department of Labor, Occupational Safety and Health Administration (OSHA), 32nd Floor, Room 3244, 230 South Dearborn Street, Chicago, IL 60604.

Safety

All safety rules defined in the above documents and all owner/employer safety rules must be strictly followed when working on the Martin® Torsion VPlow Plus.

Materials required

Only standard hand tools are needed to install this equipment.

Before Installing V-Plow

IMPORTANT

Read entire section before beginning work.

1. Inspect the shipping container for damage. Report damage to the delivery service. Fill out the damage report and return it to Martin Engineering.
2. Remove the Martin® Torsion VPlow Plus from the shipping container. Equipment in the container should include the following:
 - Martin® Torsion VPlow Plus Assembly.
 - Conveyor Products Warning Label, P/N 23395.
 - Flying Objects Warning Label, P/N 38227.
3. If anything is missing or damaged, contact Martin Engineering or representative. Fill out the warranty card and return it to Martin Engineering.



WARNING

Before installing equipment, turn off and lockout / tagout / blockout / testout all energy sources to conveyor and conveyor accessories.

4. Turn off and lockout / tagout / blockout / testout energy source according to ANSI standards (see “References”).

WARNING

If equipment will be installed in an enclosed area, test gas level or dust content before using a cutting torch or welding. Using a cutting torch or welding in an area with gas or dust may cause an explosion.



5. If using a cutting torch or welding, test the atmosphere for gas level or dust content. Cover the conveyor belt with a fire-retardant cover.

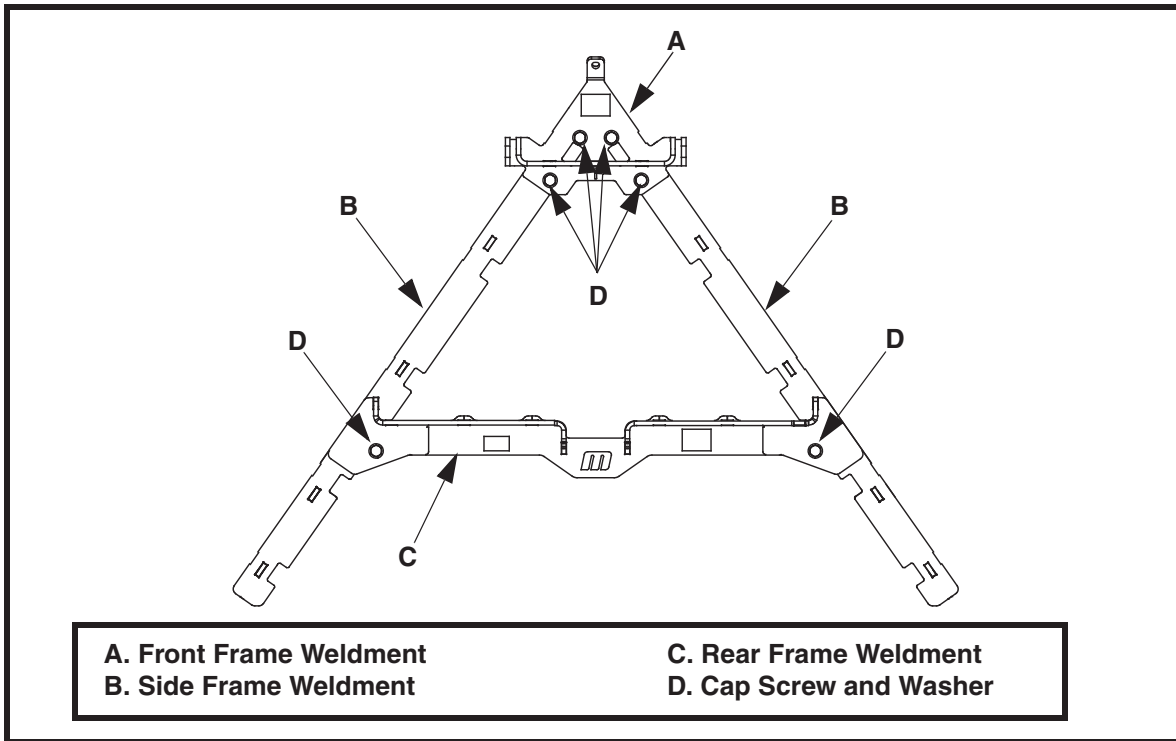

Figure 1. Assembling V-Plow

1. Fasten front frame weldment (A), side frame weldments (B), and rear frame weldment (C) together using cap screws and washers (D).
2. Place the v-plow on the return side of the belt before the tail pulley with the “V” pointing away from the tail pulley.

NOTE

Do not place a return idler directly under the plow. The idler may change the belt line and cause a portion of the blade to not contact the belt.

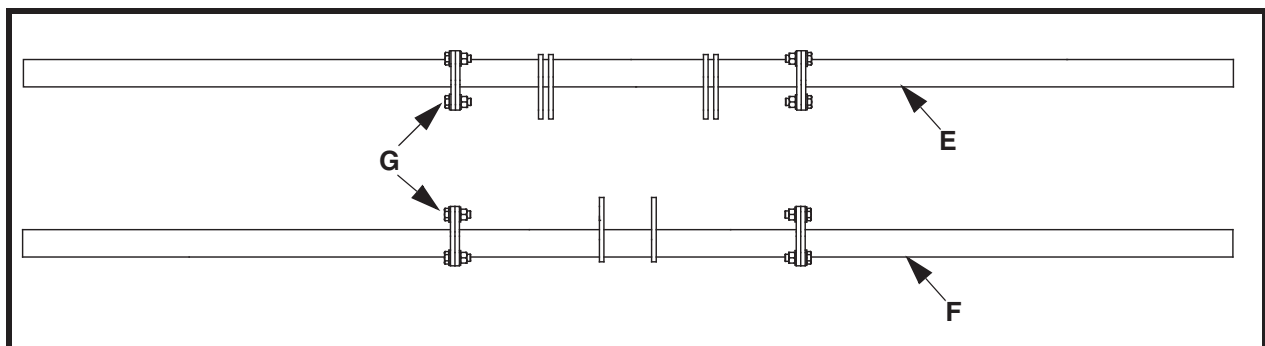
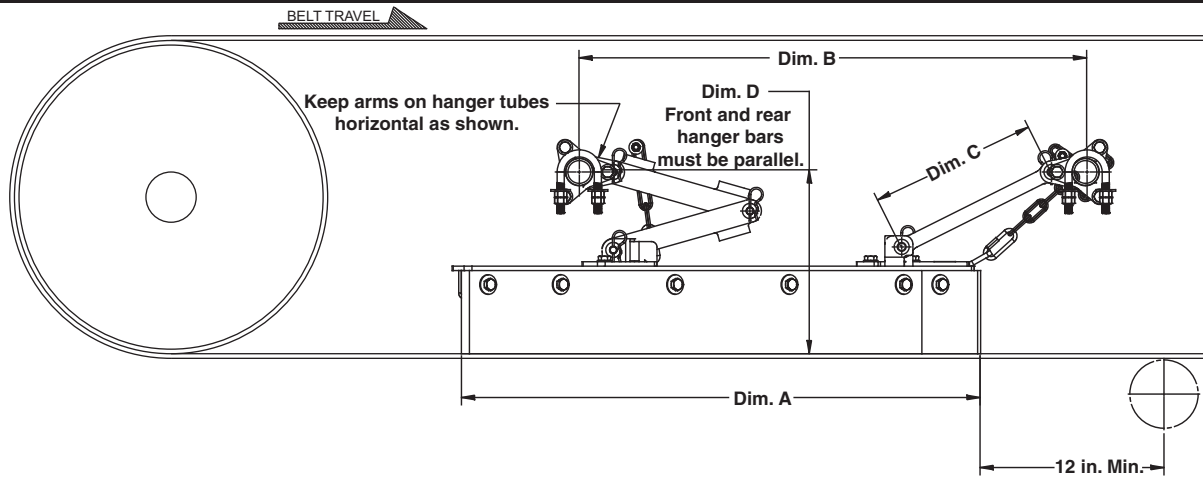

Figure 2. Assembling Hanger Bars

3. Assemble front and rear hanger bars (E and F) using cap screw, washers, and nuts (G).



Assembly Part Number	Dim. A
CPVTAS24XXXXXX	19.48 (178)
CPVTAS30XXXXXX	23.77 (254)
CPVTAS36XXXXXX	28.05 (316)
CPVTAS42XXXXXX	32.33 (316)
CPVTAS48XXXXXX	36.62 (468)
CPVTAS54XXXXXX	40.90 (468)
CPVTAS60XXXXXX	45.19 (468)

Assembly Part Number	Dim. A
CPVTAS66XXXXXX	49.47 (671)
CPVTAS72XXXXXX	53.76 (671)
CPVTAS78XXXXXX	58.04 (900)
CPVTAS84XXXXXX	62.33 (900)
CPVTAS96XXXXXX	70.90 (900)
CPVTASA8XXXXXX	79.46 (1281)
CPVTASC0XXXXXX	88.03 (1281)

Assembly Part Number	Dim. B with 7.87 Arms		Dim. B with 11.81 Arms	
	When arms are at Min. height (see Dim. D)	When arms are at Max. height (see Dim. D)	When arms are at Min. height (see Dim. D)	When arms are at Max. height (see Dim. D)
CPVTAS24XXXXXX — CPVTAS36XXXXXX	24.21 (615)	23.47 (596)	28.21 (717)	25.67 (652)
CPVTAS42XXXXXX — CPVTAS48XXXXXX	32.81 (833)	32.07 (815)	36.81 (935)	34.27 (870)
CPVTAS54XXXXXX — CPVTAS66XXXXXX	41.73 (1060)	40.99 (1041)	45.73 (1162)	43.19 (1097)
CPVTAS72XXXXXX — CPVTAS84XXXXXX	54.52 (1385)	53.78 (1366)	58.52 (1486)	55.98 (1422)
CPVTAS96XXXXXX — CPVTASA8XXXXXX	70.27 (1785)	69.53 (1766)	74.27 (1886)	71.73 (1822)
CPVTASC0XXXXXX	86.02 (2185)	85.28 (2166)	90.02 (2287)	87.48 (2222)

Assembly Part Number	Hanger Arm P/N	Dim. C	Dim. D	
			Min.	Max.
CPVTASXXO03XXX	38965A-0787X	7.87 (200)	9.25 (235)	11.25 (286)
CPVTASXXR03XXX	38965A-0787X	7.87 (200)	7.38 (188)	11.38 (289)
CPVTASXXO04XXX	38965A-1181X	11.81 (300)	9.25 (235)	15.00 (381)
CPVTASXXR04XXX	38965A-1181X	11.81 (300)	7.38 (188)	15.13 (384)

Figure 3. Locating V-Plow on Belt

4. Locate the hanger bars according to and Figure 3. Mark the location of the hanger bars on the stringers.
5. Determine how to mount the hanger bars:
 - a. If the stringers can accommodate the hanger bars in the proper position, hanger bars can be mounted directly to the stringers. See Figure 4.
 - b. If the stringers are too high or too low to accommodate the hanger bars in the proper position, adapter plates can be mounted to the stringer. See Figure 5.

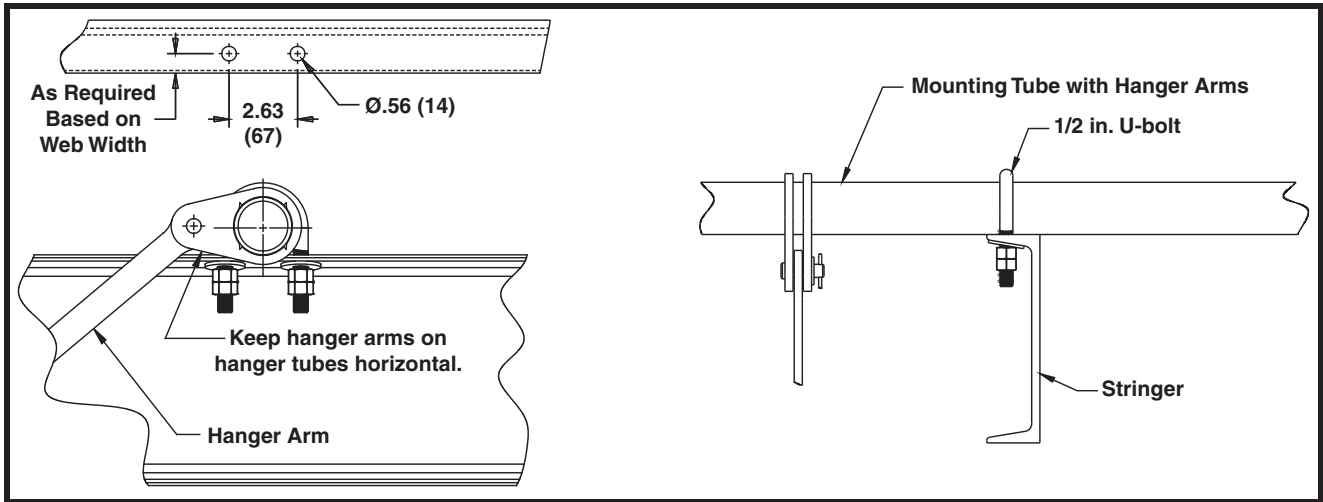

Figure 4. Installing Mounting Tubes

Installing mounting tubes

1. Bolt hanger bars to the stringers as follows:
 - (1) Drill or cut two 9/16-in. (14-mm) holes for the mounting screws for each adapter flange.
 - (2) Remove burrs and sharp edges.
 - (3) Install each hanger bar onto the stringer with two u-bolts, flat washers, and hex nuts. Hand tighten only.

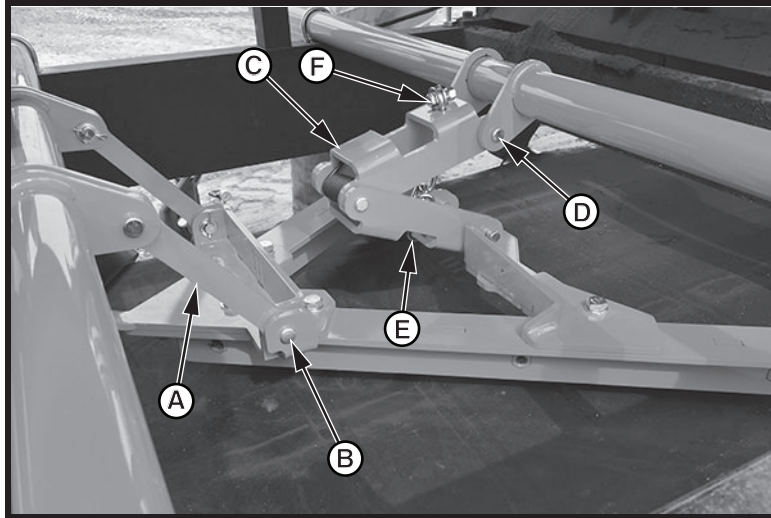

Figure 5. Installing V-Plow on Hanger Bars

Installing V-Plow

1. Attach each hanger pivot arm (A) to the front hanger bar and v-plow with a clevis pin, flat washer, and cotter pin (B).
2. Attach torsion clamp assembly (C) to the rear hanger bar and v-plow with a clevis pin, flat washer, and cotter pin (D).
3. Attach connecting link (E) on chain to lower torsion clamp arm.
4. Route chain through upper torsion clamp arm and install bolt and nut (F) through the chain link that prevents the v-plow frame from contacting belt.

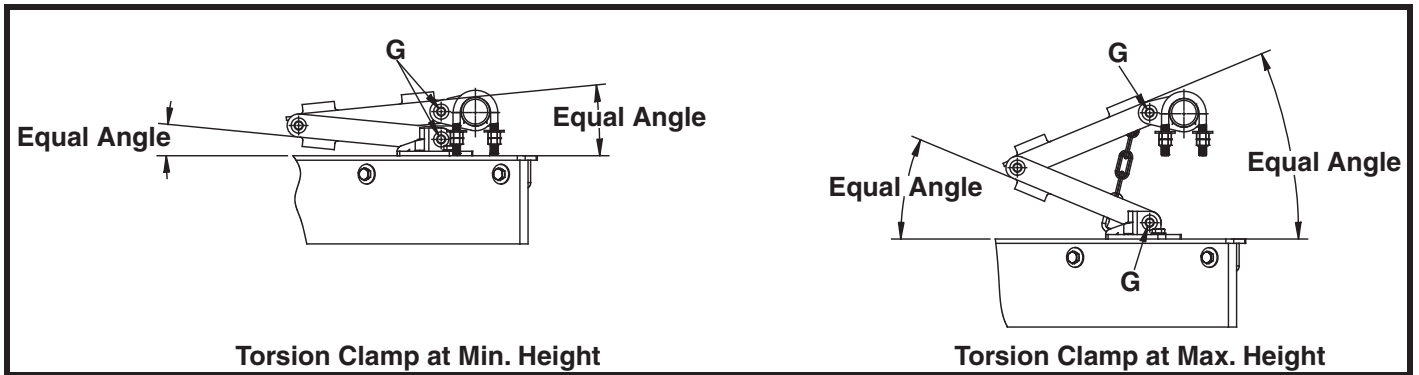

Figure 6. Torsion Clamp Position

5. Center v-plow on belt.
6. Align pins (G) so torsion clamp arms are on an equal angle.
7. Tighten all nuts on u-bolts that attach hanger bars to adapter plates or stringers. Make sure hanger arms on hanger tubes remain horizontal as shown in Figures 4.

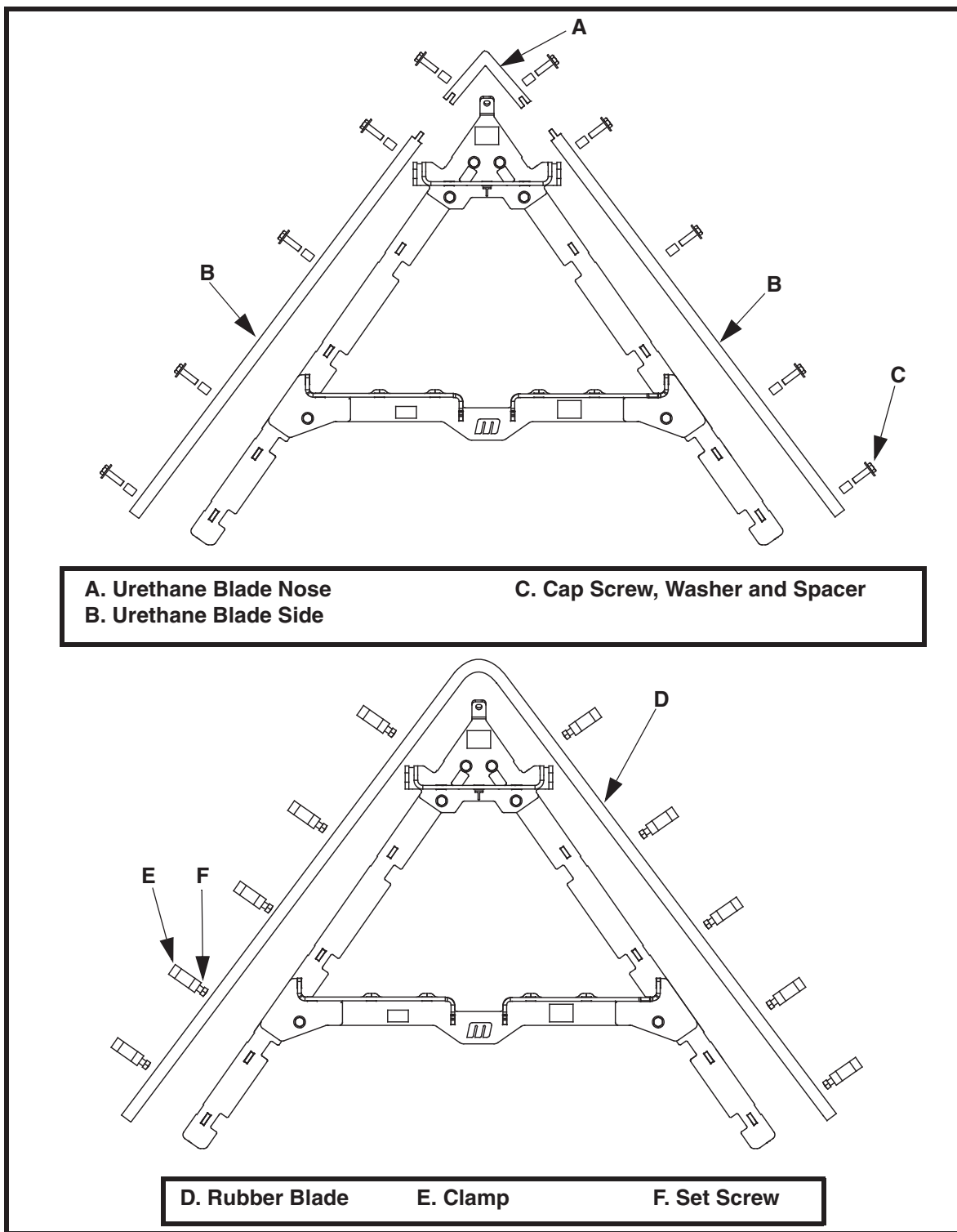

Figure 7. Installing Blade

8. Attach blade to v-plow as follows:
 - a. For v-plows with urethane blades:
 - (1) Attach nose blade (A) and side blades (B) to v-plow using cap screws, washers, and spacers (C).
 - b. For v-plows with a rubber blade:
 - (1) Attach blade (D) to v-plow using clamps (E) and set screws (F).

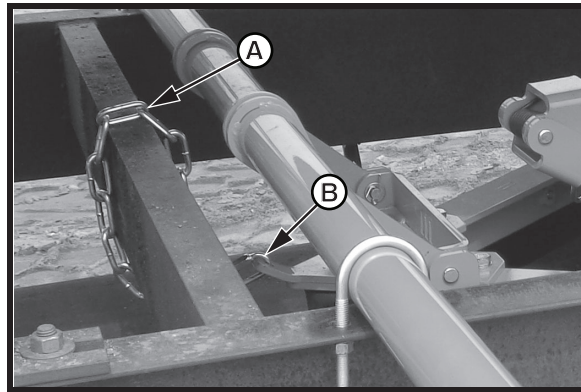

Figure 8. Installing Restraining Chain

⚠ CAUTION

Restraining chain must be installed to prevent the plow from being carried into the pulley if the mount brackets should fail. Failure to install restraining chain could severely damage the plow, pulley, and belt. Do not install restraining chain on stringers that are between the plow and tail pulley.

9. Attach restraining chain (A) to the conveyor stringers and v-plow using connecting link (B) and other hardware as required per application. Make sure v-plow is located according to chart in Figure 3. Leave no more than 2 in. (51 mm) of slack in chain.

After Installing V-Plow

IMPORTANT

Read entire section before beginning work.

1. Thoroughly wipe the outside chute wall clean above the v-plow on the operator side of the chute. Place a Conveyor Products Warning Label (P/N 23395) and a Flying Objects Warning Label (P/N 38227) on the chute wall visible to the belt operator.

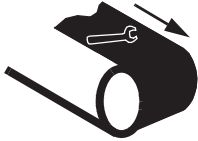

WARNING

Failure to remove tools from installation area and conveyor belt before turning on energy source can cause serious injury to personnel and damage to belt.

2. Remove all tools and the fire-retardant cover from the installation area and conveyor belt.



DANGER

Do not touch or go near conveyor belt or conveyor accessories when conveyor belt is running. Body or clothing can get caught and pull body into conveyor belt, causing severe injury or death.

3. Turn on the conveyor belt for 1 hour.



WARNING

Before adjusting v-plow, turn off and lockout / tagout / blockout / testout all energy sources to conveyor belt and conveyor accessories.

4. After 1 hour of operation, turn off and lockout / tagout / blockout / testout energy source according to ANSI standards (see “References”).
5. Make sure all fasteners are tight. Tighten if necessary.
6. Inspect the v-plow for wear. (A small amount of “break-in” wear may be found. This will stop once the blade wears to the conveyor belt contour.)
7. Make sure the plow is pushing material off the edge of the belt efficiently, leaving minimal material on the belt.
8. Repeat step 2.

Monthly Maintenance

IMPORTANT

Read entire section before beginning work.



WARNING

Before servicing v-plow, turn off and lockout / tagout / blockout / testout all energy sources to conveyor belt and conveyor accessories.

1. Turn off and lockout / tagout / blockout / testout energy source according to ANSI standards (see “References”).
2. Make sure all fasteners are tight. Tighten if necessary.
3. Check the cleaning edge for wear. If it is worn almost to the frame weldment, replace as follows (see Figure 8):
 - a. For v-plows with urethane blades:
 - (1) Remove cap screws, washers, and spacers (C).
 - (2) Remove worn side blades (B) and nose blade (A).
 - (3) Attach new nose blade (A) and side blades (B) to v-plow using cap screws, washers, and spacers (C).
 - b. For v-plows with a rubber blade:
 - (1) Loosen set screws (C) and remove clamps (B).
 - (2) Remove worn blade (A).
 - (3) Attach new blade (A) to v-plow using clamps (B) and set screws (C).
4. Check the restraining chain for wear. Make sure the chain is securely attached to the stringers.
5. Wipe all labels clean. If the labels are not readable, contact Martin Engineering or your representative for replacements.

WARNING

Failure to remove tools from installation area and conveyor belt before turning on energy source can cause serious injury to personnel and damage to belt.

6. Remove all tools from the maintenance area.

DANGER

Do not touch or go near conveyor belt or conveyor accessories when conveyor belt is running. Body or clothing can get caught and pull body into conveyor belt, causing severe injury or death.

7. Start the conveyor belt.

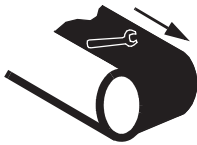

Part Numbers

This section provides product names and corresponding part numbers for the Martin® Torsion VPlow Plus and related equipment. Please reference the part numbers when ordering parts.

Martin® Torsion VPlow Plus Assembly

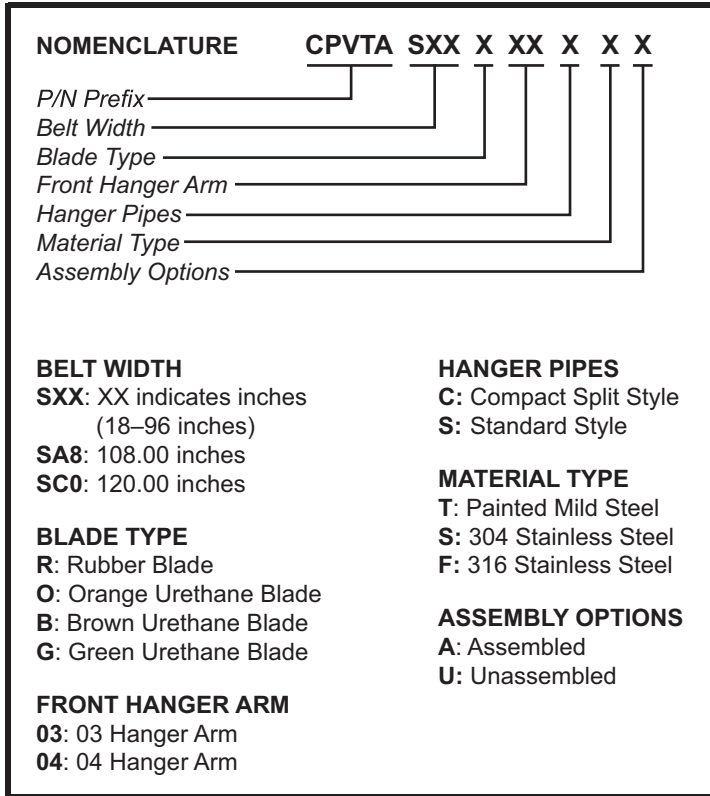

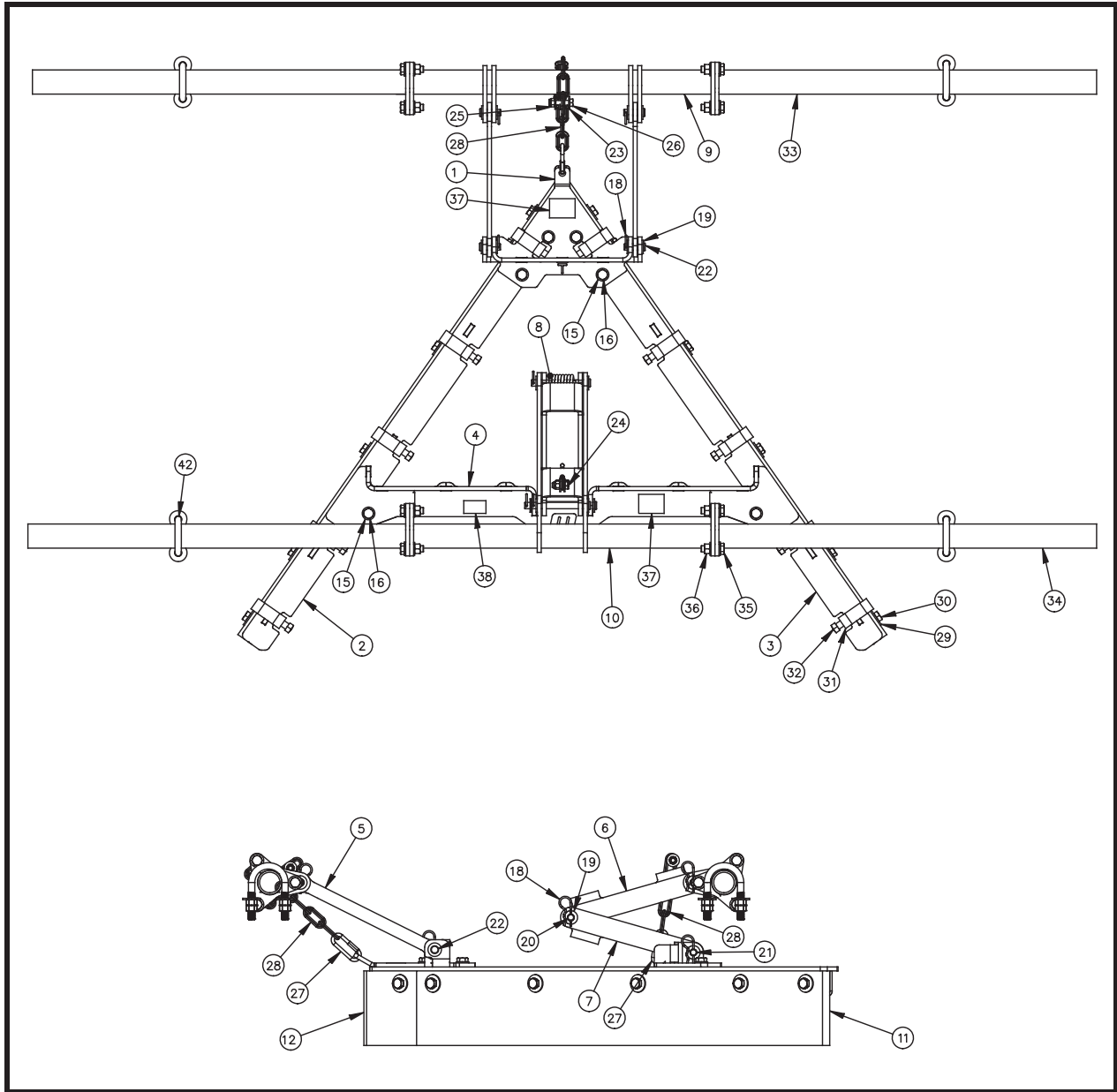

Figure 9. Martin® Torsion VPlow Plus Assembly, P/N CPVTASXXXXXXXX

Item	Description	Part No.*	Qty
1	Front Frame Hanger Weldment	CPVTP10005T	1
2	Left Wing Weldment	Table II	1
3	Right Wing Weldment	Table II	1
4	Frame Crossbar Weldment	Table II	1
5	Hanger Arm	Table IV	2
6	Torsion Hinge Top	Table V	Table VI
7	Torsion Hinge Bottom	Table V	Table VI
8	Torsion Spring	CPVTP10029	Table VI

Item	Description	Part No.*	Qty
9	Center Hanger Bar	Table II	1
10	Center Rear Hanger Bar	Table II	1
11	Urethane Blade Nose	Table III	Table VII
12	Urethane Blade Side	Table VII	Table VII
13	Rubber Blade 1.00 x 4.00	Table VII	Table VII
14	Center Brace	Table II	1
15	Washer Compression 1/2	11750	Table VI
16 (NS)	Screw HHC 1/2-13NC x 1	13842	Table VI
17 (NS)	Center Brace	Table II	1
18	Hairpin Cotter .12 Dia. x 2.38 ZP	33891	Table VI
19	Washer Flat 1/2 Narrow	31010	Table VI
20 (NS)	Pin Clevis 1/2 x 4-1/2	SP01323-20	Table VI
21	Pin Clevis 1/2 x 5-1/2	32180-06	Table VI
22	Pin Clevis 1/2 x 1-1/2	30689	4
23	Washer Flat 3/8 Wide	18007	Table VI
24	Screw HHC 3/8-16NC x 1	11746-02	Table VI
25	Nut Hex Elastic Lock 3/8-16NC	14201	Table VI
26	Screw HHC 3/8-16NC x 1-1/2	32719	1
27	Chain Connector 9/16 x 2-5/16	39070	Table VI
28	Chain STL Coil 1/4 Dia.	100897	Table VI
29	Washer Flat 1/2 Wide	17328	Table VII
30	Screw HHC 1/2-13NC x 1-3/4	23478	Table VII
31	Rubber Blade Clamp	CPVTP10055T	Table VII
32	Screw SHS 1/2-13NC x 1-1/2 SS	33190	Table VII
33	End Hanger Bar	Table II	2
34	End Rear Hanger Bar	Table II	2
35	Screw HHC 1/2-13NC x 1-1/2 ZP	11763	12
36	Nut Hex 1/2-13NC ZP	11771	12
37	Label Pinch Point	30528	2
38	Label Martin Product Small	32238	1
39 (NS)	Label Flying Objects Warning	38227	2
40 (NS)	Label Conveyor Products Warning	23395	2
41 (NS)	Manual Operator's	M4083	1
42 (NS)	U-Bolt Extended LG F/2" Pipe 1/2-13NC	39071	4

*Contact Martin Engineering for part numbers used in stainless steel assemblies.

Figure 9. Martin® Torsion VPlow Plus Assembly, P/N CPVTASXXXXXXXX

Table II. Martin® Torsion VPlow Plus Item Part Numbers

Assembly Part No.	Part No. Item 2	Part No. Item 3	Part No. Item 4	Part No. Item 9
CPVTAS24XXXXXX	CPVTP10001S24LX	CPVTP10001S24RX	CPVTP1001001X	CPVTP1004001X
CPVTAS30XXXXXX	CPVTP10001S30LX	CPVTP10001S30RX	CPVTP1001001X	CPVTP1004001X
CPVTAS36XXXXXX	CPVTP10001S36LX	CPVTP10001S36RX	CPVTP1001001X	CPVTP1004001X
CPVTAS42XXXXXX	CPVTP10001S42LX	CPVTP10001S42RX	CPVTP1001002X	CPVTP1004001X
CPVTAS48XXXXXX	CPVTP10001S48LX	CPVTP10001S48RX	CPVTP1001002X	CPVTP1004001X
CPVTAS54XXXXXX	CPVTP10001S54LX	CPVTP10001S54RX	CPVTP1001003X	CPVTP1004002X
CPVTAS60XXXXXX	CPVTP10001S60LX	CPVTP10001S60RX	CPVTP1001003X	CPVTP1004002X
CPVTAS66XXXXXX	CPVTP10001S66LX	CPVTP10001S66RX	CPVTP1001003X	CPVTP1004002X
CPVTAS72XXXXXX	CPVTP10001S72LX	CPVTP10001S72RX	CPVTP1001004X	CPVTP1004002X
CPVTAS78XXXXXX	CPVTP10001S78LX	CPVTP10001S78RX	CPVTP1001004X	CPVTP1004002X
CPVTAS84XXXXXX	CPVTP10001S84LX	CPVTP10001S84RX	CPVTP1001004X	CPVTP1004003X
CPVTAS96XXXXXX	CPVTP10001S96LX	CPVTP10001S96RX	CPVTP1001005X	CPVTP1004003X
CPVTASA8XXXXXX	CPVTP10001SA8LX	CPVTP10001SA8RX	CPVTP1001005X	CPVTP1004003X
CPVTASC0XXXXXX	CPVTP10001SC0LX	CPVTP10001SC0RX	CPVTP1001006X	CPVTP1004003X

Assembly Part No.	Part No. Item 10	Part No. Item 14	Part No. Item 17	Part No. Item 33	Part No. Item 34
CPVTAS24XXXXXX	CPVTP1004501X	—	—	CPVTP1005002X	CPVTP1005002X
CPVTAS30XXXXXX	CPVTP1004501X	—	—	CPVTP1005003X	CPVTP1005003X
CPVTAS36XXXXXX	CPVTP1004501X	—	—	CPVTP1005004X	CPVTP1005004X
CPVTAS42XXXXXX	CPVTP1004501X	—	—	CPVTP1005005X	CPVTP1005005X
CPVTAS48XXXXXX	CPVTP1004501X	—	—	CPVTP1005006X	CPVTP1005006X
CPVTAS54XXXXXX	CPVTP1004502X	CPVTP1001801X	—	CPVTP1005005X	CPVTP1005005X
CPVTAS60XXXXXX	CPVTP1004502X	CPVTP1001801X	—	CPVTP1005006X	CPVTP1005006X
CPVTAS66XXXXXX	CPVTP1004502X	CPVTP1001801X	—	CPVTP1005007X	CPVTP1005007X
CPVTAS72XXXXXX	CPVTP1004503X	CPVTP1001802X	—	CPVTP1005008X	CPVTP1005006X
CPVTAS78XXXXXX	CPVTP1004503X	CPVTP1001802X	—	CPVTP1005009X	CPVTP1005007X
CPVTAS84XXXXXX	CPVTP1004503X	CPVTP1001802X	—	CPVTP1005008X	CPVTP1005008X
CPVTAS96XXXXXX	CPVTP1004504X	CPVTP1001802X	CPVTP1001803X	CPVTP1005010X	CPVTP1005007X
CPVTASA8XXXXXX	CPVTP1004504X	CPVTP1001802X	CPVTP1001803X	CPVTP1005012X	CPVTP1005009X
CPVTASC0XXXXXX	CPVTP1004505X	CPVTP1001802X	CPVTP1001804X	CPVTP1005014X	CPVTP1005008X

Table III. Martin® Torsion VPlow Plus Urethane Blade Color

Assembly Part No.	Part No. Item 11	Part No. Item 12	Blade Color
CPVTASXXOXXXXX	CPVTB001O	CPVTBSXXO	Orange
CPVTASXXBXXXXX	CPVTB001B	CPVTBSXXB	Brown
CPVTASXXGXXXXX	CPVTB001G	CPVTBSXXG	Green

Table IV. Martin® Torsion VPlow Plus Hanger Arms

Assembly Part No.	Part No. Item 5	Hanger Arm Length in. (mm)
CPVTASXXX03XXX	38965A-0787X	7.87 (200)
CPVTASXXX04XXX	38965A-1181X	11.81 (300)

Table V. Martin® Torsion VPlow Plus Torsion Arm Part Numbers

Assembly Part No.	Part No. Item 6	Part No. Item 7
CPVTAS24XXXXXX — CPVTAS36XXXXXX	CPVTP1002501X	CPVTP1002701X
CPVTAS42XXXXXX — CPVTASC0XXXXXX	CPVTP1002502X	CPVTP1002702X

Table VI. Martin® Torsion VPlow Plus Quantities

Assembly Part No.	Qty Items 6,7,8,21 & 24	Qty Items 15 & 16	Qty Item 18	Qty Item 19	Qty Item 20	Qty Item 23	Qty Items 25 & 27	Qty Item 28
CPVTAS24XXXXXX — CPVTAS48XXXXXX	1	6	7	26	2	4	2	5 ft
CPVTAS54XXXXXX — CPVTAS84XXXXXX	2	10	10	32	4	6	3	7 ft
CPVTAS96XXXXXX — CPVTASC0XXXXXX	3	14	13	38	6	8	4	9 ft

Table VII. Martin® Torsion VPlow Plus Blade Part Numbers and Quantities

Assembly Part No.	Part No. Item 12	Part No. Item 13	Qty Item 11	Qty Item 12	Qty Item 13	Qty Item 29	Qty Item 30	Qty Items 31 & 32
CPVTAS24RXXXXX	—	CPVTBS24R	0	0	1	8	0	4
CPVTAS24XXXXXX	CPVTBS24X	—	1	2	0	16	8	0
CPVTAS30RXXXXX	—	CPVTBS30R	0	0	1	8	0	6
CPVTAS30XXXXXX	CPVTBS30X	—	1	2	0	16	8	0
CPVTAS36RXXXXX	—	CPVTBS36R	0	0	1	8	0	6
CPVTAS36XXXXXX	CPVTBS36X	—	1	2	0	18	10	0
CPVTAS42RXXXXX	—	CPVTBS42R	0	0	1	8	0	8
CPVTAS42XXXXXX	CPVTBS42X	—	1	2	0	18	10	0

Part Numbers

Assembly Part No.	Part No. Item 12	Part No. Item 13	Qty Item 11	Qty Item 12	Qty Item 13	Qty Item 29	Qty Item 30	Qty Items 31 & 32
CPVTAS48RXXXXXX	—	CPVTBS48R	0	0	1	8	0	10
CPVTAS48XXXXXX	CPVTBS48X	—	1	2	0	20	12	0
CPVTAS54RXXXXXX	—	CPVTBS54R	0	0	1	8	0	10
CPVTAS54XXXXXX	CPVTBS54X	—	1	2	0	20	12	0
CPVTAS60RXXXXXX	—	CPVTBS60R	0	0	1	8	0	10
CPVTAS60XXXXXX	CPVTBS60X	—	1	2	0	22	14	0
CPVTAS66RXXXXXX	—	CPVTBS66R	0	0	1	8	0	12
CPVTAS66XXXXXX	CPVTBS66X	—	1	2	0	22	14	0
CPVTAS72RXXXXXX	—	CPVTBS72R	0	0	1	8	0	12
CPVTAS72XXXXXX	CPVTBS72X	—	1	2	0	24	16	0
CPVTAS78RXXXXXX	—	CPVTBS78R	0	0	1	8	0	14
CPVTAS78XXXXXX	CPVTBS78X	—	1	2	0	24	16	0
CPVTAS84RXXXXXX	—	CPVTBS84R	0	0	1	8	0	14
CPVTAS84XXXXXX	CPVTBS84X	—	1	2	0	26	18	0
CPVTAS96RXXXXXX	—	CPVTBS96R	0	0	1	8	0	16
CPVTAS96XXXXXX	CPVTBS96X	—	1	2	0	28	20	0
CPVTASA8RXXXXXX	—	CPVTBSA8R	0	0	1	8	0	19
CPVTASA8XXXXXX	CPVTBSA8X	—	1	2	0	30	22	0
CPVTASC0RXXXXXX	—	CPVTBSC0R	0	0	1	8	0	18
CPVTASC0XXXXXX	CPVTBSC0X	—	1	2	0	32	21	0

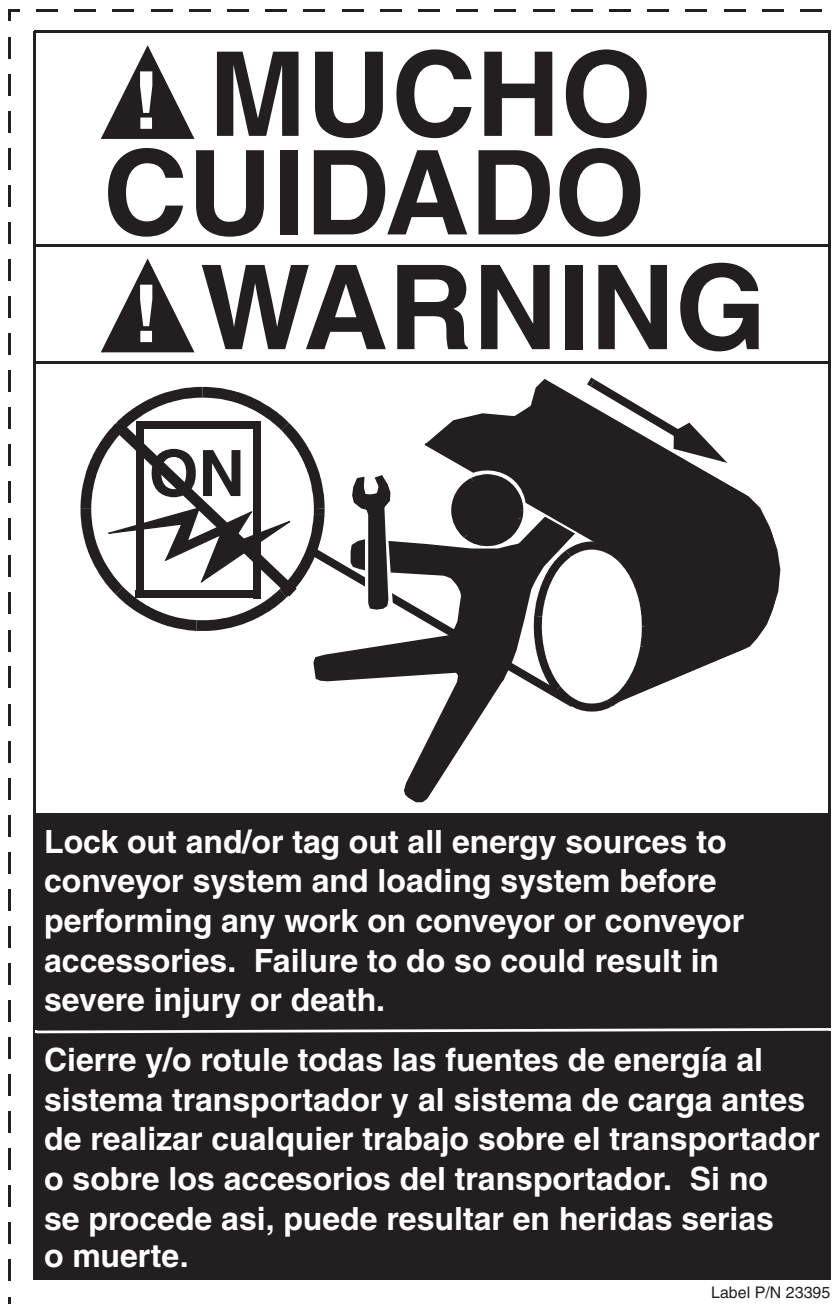

Figure 10. Conveyor Products Warning Label, P/N 23395



Figure 11. Flying Objects Warning Label, P/N 38227

Any product, process, or technology described here may be the subject of intellectual property rights reserved by Martin Engineering Company. Trademarks or service marks designated with the ® symbol are registered with the U.S. Patent and Trademark Office and may be proprietary in one or more countries or regions. Other trademarks and service marks belonging to Martin Engineering Company in the United States and/or other countries or regions may be designated with the “TM” and “SM” symbols. Brands, trademarks, and names of other parties, who may or may not be affiliated with, connected to, or endorsed by Martin Engineering Company, are identified wherever possible. Additional information regarding Martin Engineering Company’s intellectual property can be obtained at www.martin-eng.com/trademarks.

Problem Solved™ ***GUARANTEED!***

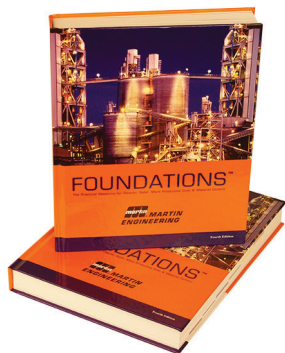

For nearly 20 years, Martin Engineering's Foundations™ Books have taught industry personnel to operate and maintain clean and safe belt conveyors. The Foundations™ Book, fourth edition, focuses on improving belt conveyors by controlling fugitive material. "The Practical Resource for Total Dust and Material Control," is a 576-page hard cover volume that provides information of value to industries where the efficient handling of bulk materials is a key to productivity and profitability.

Expanding upon the book, our Foundations™ Training Program addresses the design and development of more productive belt conveyors, and is offered in three customizable seminars. Attendees gain a better understanding of conveyor safety and performance, helping to justify upgrade investments and increase profitability.



Martin Engineering USA

One Martin Place
Neponset, IL 61345-9766 USA
800 544 2947 or 309 852 2384
Fax 800 814 1553
www.martin-eng.com

**COMPANY WITH
QUALITY SYSTEM
CERTIFIED BY DNV
= ISO 9001:2008 =**