

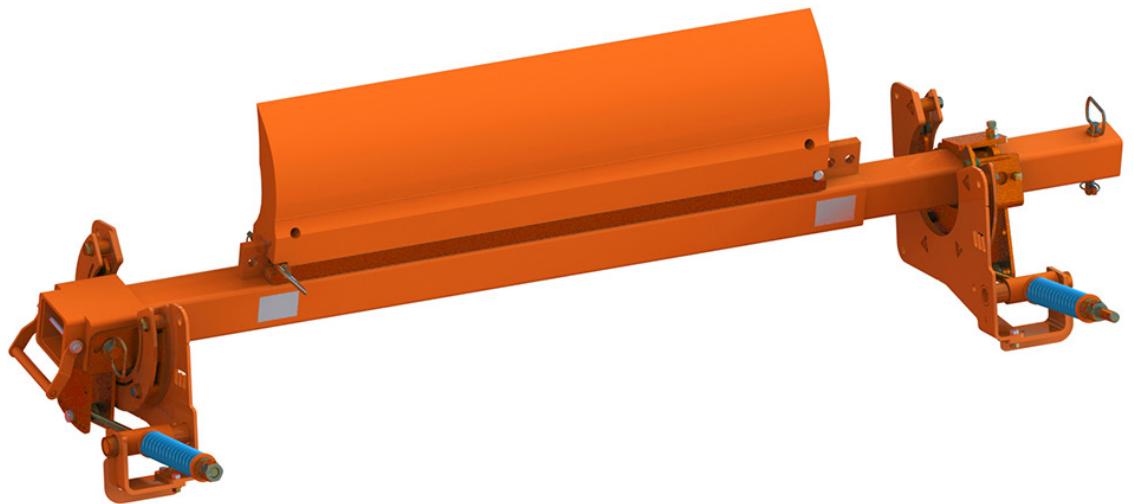

Martin[®] QC1[™] Cleaner XHD STS[™]

[Go to Martin[®] QC1[™] Cleaner XHD STS[™] web page](#)



Operator's Manual
M3987

Important

MARTIN ENGINEERING HEREBY DISCLAIMS ANY LIABILITY FOR: DAMAGE DUE TO CONTAMINATION OF THE MATERIAL; USER'S FAILURE TO INSPECT, MAINTAIN AND TAKE REASONABLE CARE OF THE EQUIPMENT; INJURIES OR DAMAGE RESULTING FROM USE OR APPLICATION OF THIS PRODUCT CONTRARY TO INSTRUCTIONS AND SPECIFICATIONS CONTAINED HEREIN. MARTIN ENGINEERING'S LIABILITY SHALL BE LIMITED TO REPAIR OR REPLACEMENT OF EQUIPMENT SHOWN TO BE DEFECTIVE.

Observe all safety rules given herein along with owner and Government standards and regulations. Know and understand lockout/tagout procedures as defined by American National Standards Institute (ANSI) z244.1-1982, *American National Standard for Personnel Protection - Lockout/Tagout of Energy Sources - Minimum Safety Requirements* and Occupational Safety and Health Administration (OSHA) Federal Register, Part IV, 29 CFR Part 1910, *Control of Hazardous Energy Source (Lockout/Tagout); Final Rule*.

The following symbols may be used in this manual:



Danger: Immediate hazards that will result in severe personal injury or death.



Warning: Hazards or unsafe practices that could result in personal injury.



Caution: Hazards or unsafe practices that could result in product or property damages.



Important: Instructions that must be followed to ensure proper installation/operation of equipment.



Note: General statements to assist the reader.

Table of Contents

Section	Page
List of Figures/Tables	ii
Introduction	1
General	1
Installations Without Chutework	1
Belt Cleaner Inspection Access	1
References	1
Safety	2
Urethane Shelf Life	3
Before Installing Belt Cleaner	4
Installing Belt Cleaner	7
Locating Cleaner Centerline	7
Marking Chute Cutouts	9
Installing Belt Cleaner	10
Adjusting Spring Tensioner	11
Installing Air Cylinder Tensioners	12
After Installing Belt Cleaner	13
Maintenance	14
Blade Servicing	14
Troubleshooting/Installation Checklist	17
Part Numbers	19

List of Figures

Figure	Title	Page
1	Belt Cleaner Locations	5
2	Belt Cleaner Location	7
3	Operator Side Chute Cutout	8
4	Far Side Chute Cutout	8
5	Installing Belt Cleaner	10
6	Adjusting Spring Tensioner	11
7	Installing Air Cylinder Tensioner	12
8	Blade Replacement	15
9	Martin [®] QC1 [™] Cleaner XHD STS [™] Assembly, P/N STSXHDQC-XXXXXXXX	20
10	Martin [®] Spring Tensioner XHD STS [™] , P/N 39100-XHDSXSQ	22
11	Martin [®] Air Cylinder Tensioner XHD STS [™] , P/N 39100-XHDASQ	24
12	Conveyor Products Warning Label, P/N 23395	26
13	Pinch Point Warning Label, P/N 30528	26
14	Martin [®] Spring Tensioner XHD STS [™] Tensioning Label, P/N 39438-S	27
15	Martin [®] Air Tensioner XHD STS [™] Tensioning Label, P/N 39438-A	27

List of Tables

Table	Title	Page
I	Martin [®] QC1 [™] Cleaner XHD Blade Colors, Materials and Specifications	3
II	Urethane Shelf Life	3
III	Spring Tensioner Settings	11
IV	Air Cylinder Tensioner Settings	12
V	Martin [®] QC1 [™] Cleaner XHD STS [™] Assembly Part Numbers	21
VI	Martin [®] QC1 [™] Blade XHD	21
VII	Martin [®] Spring Tensioner XHD STS [™] Part Numbers	23

Introduction

General

To introduce product back into the product flow, a Pre-Cleaner is installed on the face of the head pulley. On a dual cleaner system, the Secondary Cleaner is installed immediately following the Pre-Cleaner to remove stubborn material left on the conveyor belt. If a Pre-Cleaner cannot be used because of space limitations, the Secondary Cleaner is installed alone. If the material-handling process or product could be affected by contamination from the use of these belt cleaners, the user is responsible for taking the necessary steps to prevent contamination. Consult Martin Engineering or a representative for alternate belt cleaners or belt cleaner locations to use where contamination may be an issue.

Installations without chutework

These procedures were written for equipment that is being installed on enclosed pulley chutework. If the pulley is not enclosed, the equipment should be installed using the best available field resources and methods to ensure that the critical dimensions are followed for proper installation.

Belt cleaner inspection access

If the belt cleaner is installed on enclosed pulley chutework, a Martin[®] Inspection Door should be installed. Martin[®] Inspection Doors are available from Martin Engineering or a representative.

References

The following documents are referenced in this manual:

- American National Standards Institute (ANSI) z244.1-1982, *American National Standard for Personnel Protection - Lockout/Tagout of Energy Sources - Minimum Safety Requirements*, American National Standards Institute Inc., 1430 Broadway, New York, NY 10018.
- Federal Register, Volume 54, Number 169, Part IV, 29 CFR Part 1910, *Control of Hazardous Energy Source (Lockout/Tagout); Final Rule*, Department of Labor, Occupational Safety and Health Administration (OSHA), 32nd Floor, Room 3244, 230 South Dearborn Street, Chicago, IL 60604.

Table I. Martin® QC1+™ Cleaner XHD Blade Colors, Materials and Specifications

URETHANE SELECTION	APPLICATION DESCRIPTION	TYPICAL MATERIALS	CONTINUOUS TEMPERATURE
Orange (O)	Standard Martin® Urethane Suitable for 80% or more of all belt cleaner applications, including abrasive conditions. Best choice for exposure to solvents or oil.	Bauxite, Coke, Coal, Overburden Refuse Steel/Ore, All Other	-20° to 160°F (-29° to 71°C)
Brown (B)	Chemical-Resistant Urethane Improves resistance to chemicals; reduced absorption of water in high-moisture environments.	Limestone	-40° to 160°F (-40° to 71°C)
Green (G)	High-Temperature Urethane For exposure to intermittent temperatures up to 350°F (177°C).	Clinker	-40° to 300°F (-40° to 149°C)
Tan (T)	Low-Rigidity Urethane For dry products such as sand and gravel.	Gravel, Dry Sand	-20° to 160°F (-29° to 71°C)
Navy Blue (N)	Low-Adhesion Urethane For sticky or tacky materials.	Cement, Glass, Wood Chips	-20° to 160°F (-29° to 71°C)
Yellow w/ Ceramic Beads (C)	Highly Abrasive-Resistant Urethane For abrasive applications.		-20° to 160°F (-29° to 71°C)

IMPORTANT*Urethane shelf life*

Urethane put in service after exceeding it's shelf life may wear differently and deteriorate quicker than normal urethane.

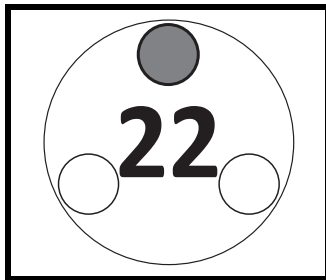
NOTE

Code Date is written near bottom of blade as mm/dd/yy-x. In addition to or in place of this date, you may see an imprinted date medallion similar to the example shown. In this example, “22” stands for the year 2022. The small circles represent the quarter of the year. If three circles are “punched” the blade was produced in the first quarter. If none of the circles are “punched” the blade was produced in the fourth quarter. If code date on your blade(s) is not legible or is missing, contact Martin Engineering or a representative.

Table II. Urethane Shelf Life

Blade Color	Shelf Life
Blue	1 Year from Code Date
Brown	2 Years from Code Date
Tan	1 Year from Code Date
Green	2 Years from Code Date
Orange	1 Year from Code Date
Yellow w/Ceramic Beads	1 Year from Code Date

Safety

All safety rules defined in the above documents and all owner/employer safety rules must be strictly followed when working on the belt cleaner.



⚠ DANGER

Do not touch or go near the conveyor belt or conveyor accessories when the belt is running. Your body or clothing can get caught and you can be pulled into the conveyor, resulting in severe injury or death.



⚠ DANGER

Before installing, servicing, or adjusting the belt cleaner, turn off and lockout / tagout / blockout / testout all energy sources to the conveyor and conveyor accessories according to ANSI standards. Failure to do so could result in serious injury or death.

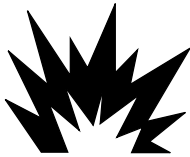

⚠ DANGER

If this equipment will be installed in an enclosed area, test the gas level or dust content before using a cutting torch or welding. Using a torch or welding in an area with gas or dust may cause an explosion resulting in serious injury or death.



⚠ WARNING

Before using a cutting torch or welding the chute wall, cover the conveyor belt with a fire retardant cover. Failure to do so can allow the belt to catch fire.

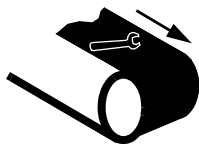

⚠ WARNING

Remove all tools from the installation area and conveyor belt before turning on the conveyor. Failure to do so can cause serious injury to personnel or damage to the belt and conveyor.



⚠ WARNING

Mainframe with blade can be heavy and may require two people to lift. Attempting to lift the belt cleaner without assistance could result in injury.

Before Installing Belt Cleaner

IMPORTANT

The delivery service is responsible for damage occurring in transit. Martin Engineering CANNOT enter claims for damages. Contact your transportation agent for more information.

1. Inspect shipping container for damage. Report damage to delivery service immediately and fill out delivery service's claim form. Keep any damaged goods subject to examination.
2. Remove belt cleaner assembly from shipping container.
3. If anything is missing contact Martin Engineering or a representative.
4. If anything is missing contact Martin Engineering or a representative.



⚠ DANGER

Before installing, servicing, or adjusting the belt cleaner, turn off and lockout / tagout / blockout / testout all energy sources to the conveyor and conveyor accessories according to ANSI standards. Failure to do so could result in serious injury or death.

5. Turn off and lockout / tagout / blockout / testout energy source according to ANSI standards (see "References").

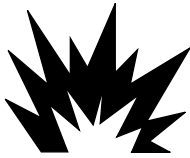

⚠ DANGER

If this equipment will be installed in an enclosed area, test the gas level or dust content before using a cutting torch or welding. Using a torch or welding in an area with gas or dust may cause an explosion resulting in serious injury or death.

6. If using a cutting torch or welding, test atmosphere for gas level or dust content. Cover conveyor belt with fire retardant cover.

IMPORTANT

Center the belt cleaner blades to clean an area narrower than the conveyor belt width. This allows for side-to-side movement of the belt and prevents damage to the belt edge.

NOTE

The chute wall that the tensioner will be located on is referred to as the "operator side." The other side of the chute is referred to as the "far side." (If installing dual tensioners, side that is most accessible is "operator side.")

7. Determine which side of chute is easiest to access. Locate the tensioner on the most accessible chute wall.

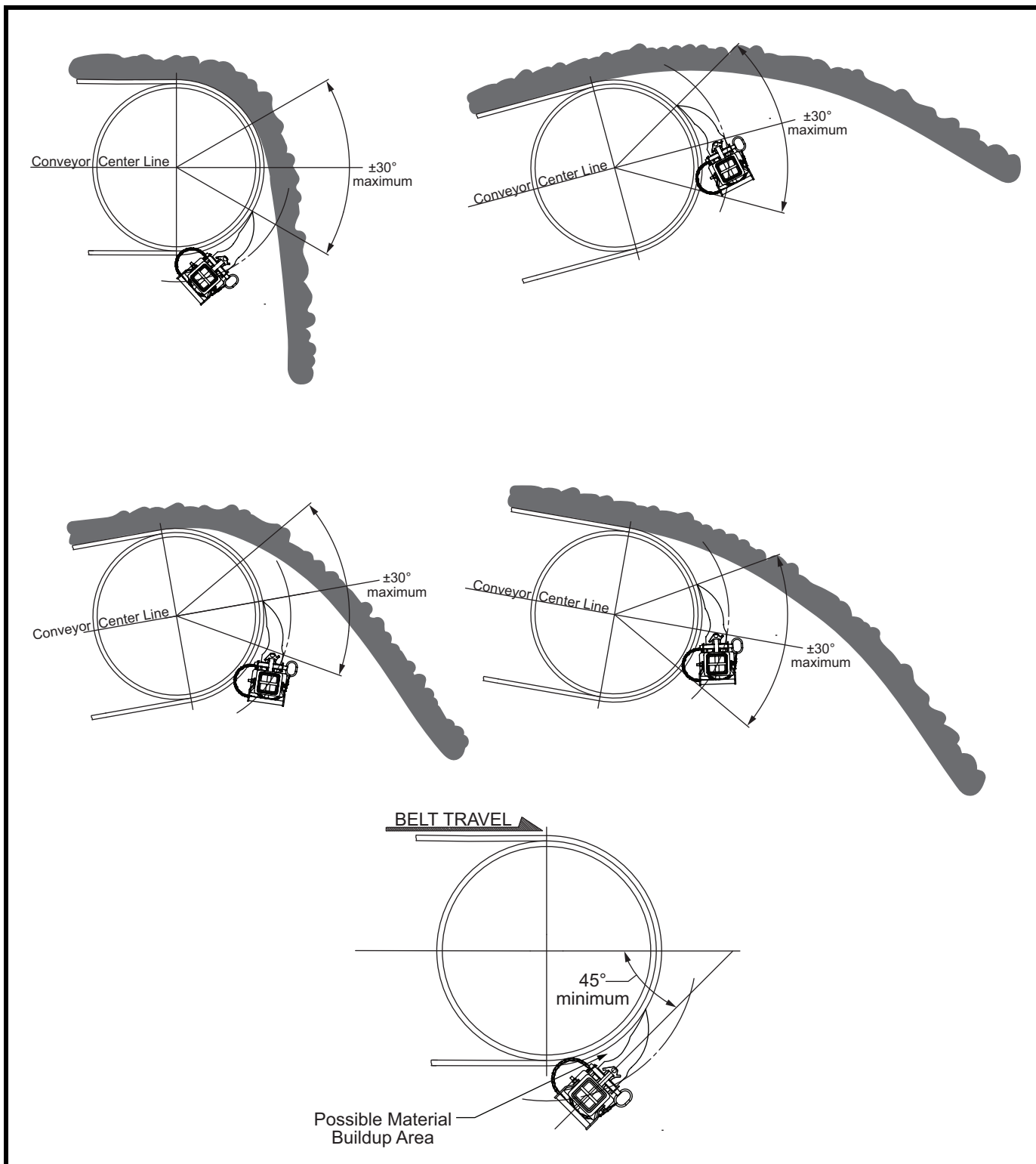

Figure 1. Belt Cleaner Mounting Locations

8. Inspect belt cleaner mounting area for possible obstructions that could interfere with proper mounting. Refer to following guidelines:
 - a. The cleaner can be mounted anywhere on the arc from +30 degrees to -30 degrees from a center line parallel to the belt line as long as:
 - (1) The blade is not in the direct flow of discharging material causing premature blade wear.
 - (2) The diameter of the pulley is big enough that the blade does not trap or hold material between the inside of the blade and the belt.
 - (3) There is at least the equivalent of a 45 degree angle between the blade and belt to prevent material buildup in this space.
 - b. Lack of service is the main cause of poor belt cleaning performance. Follow CEMA guidelines for access:
 - (1) Clearance for service outside the chute must be at least equal to the belt width.
 - (2) Cleaners must have service platforms. CEMA recommends cleaners be mounted at least 24 in. (600 mm) above the work platform.
 - (3) If the belt width is 54 in. (1400 mm) or larger consider access doors on both sides of the chute.
 - c. Refer to “Installing Belt Cleaner” and “Part Numbers” sections of this manual for specific mounting and cleaner dimensions.

Installing Belt Cleaner

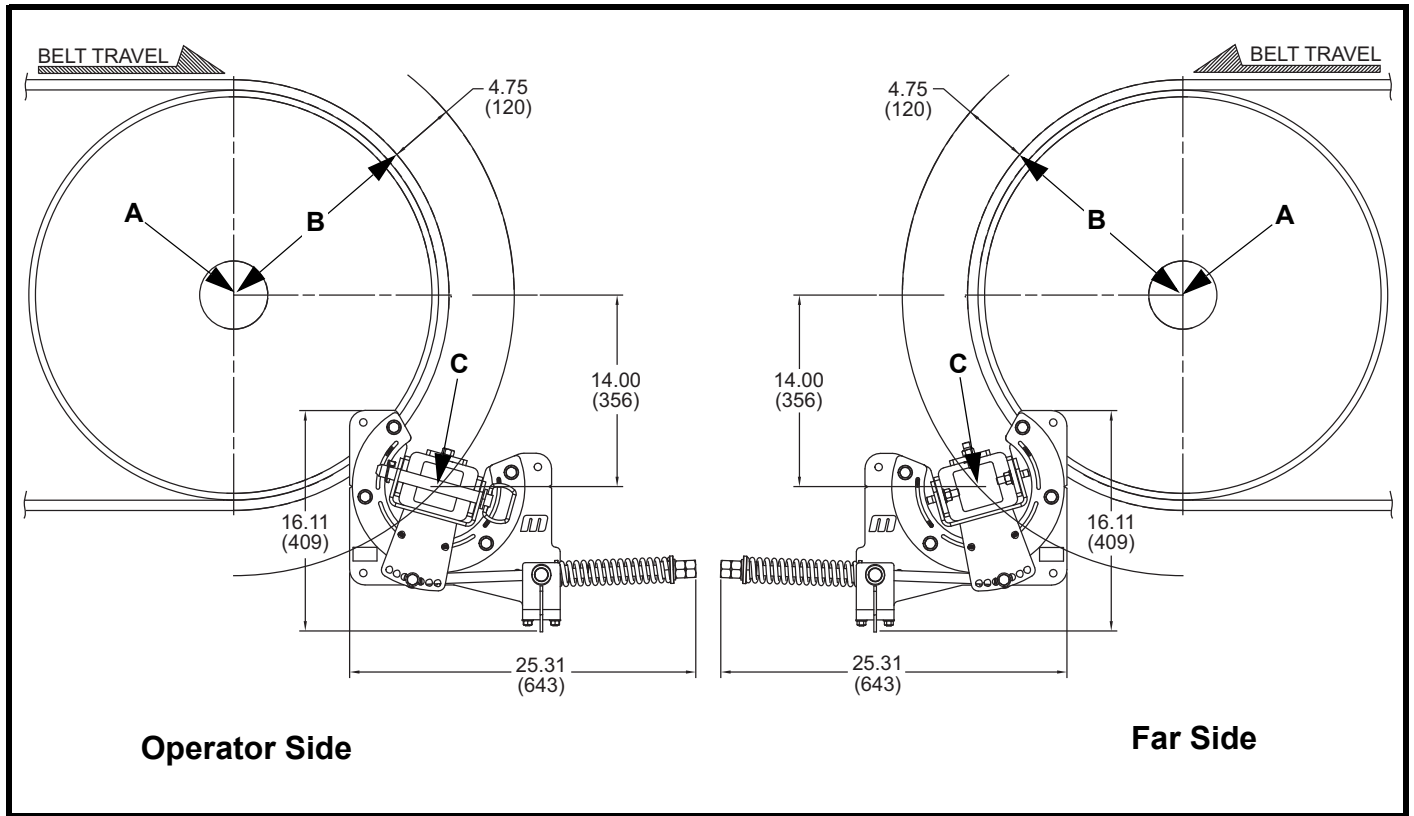

Figure 2. Belt Cleaner Location

Locating Cleaner Centerline

1. On operator side of chute, find pulley center point (A).
2. Measure radius of head pulley including lagging and belt thickness (B). To this dimension, add 4.75 in.
3. Starting from center point (A), measure the total distance calculated in step 2 ($B + 4.75$) and draw an arc on chute wall.
4. Measure down from pulley's horizontal centerline the distance shown in Figure 2 and draw a horizontal line parallel to it. Locate center point of belt cleaner mainframe (C) where this line intersects the arc on the chute wall.
5. Position tensioner on chute wall and align notches in tensioner mount with belt cleaner mainframe centerlines.
6. Using the tensioner as a template mark mounting bolt holes.
7. Make sure mainframe and blades do not lie in path of material unloading from conveyor belt. Make sure blade tip is at or below horizontal centerline.
8. Repeat steps 1 through 6 for far side of chute.

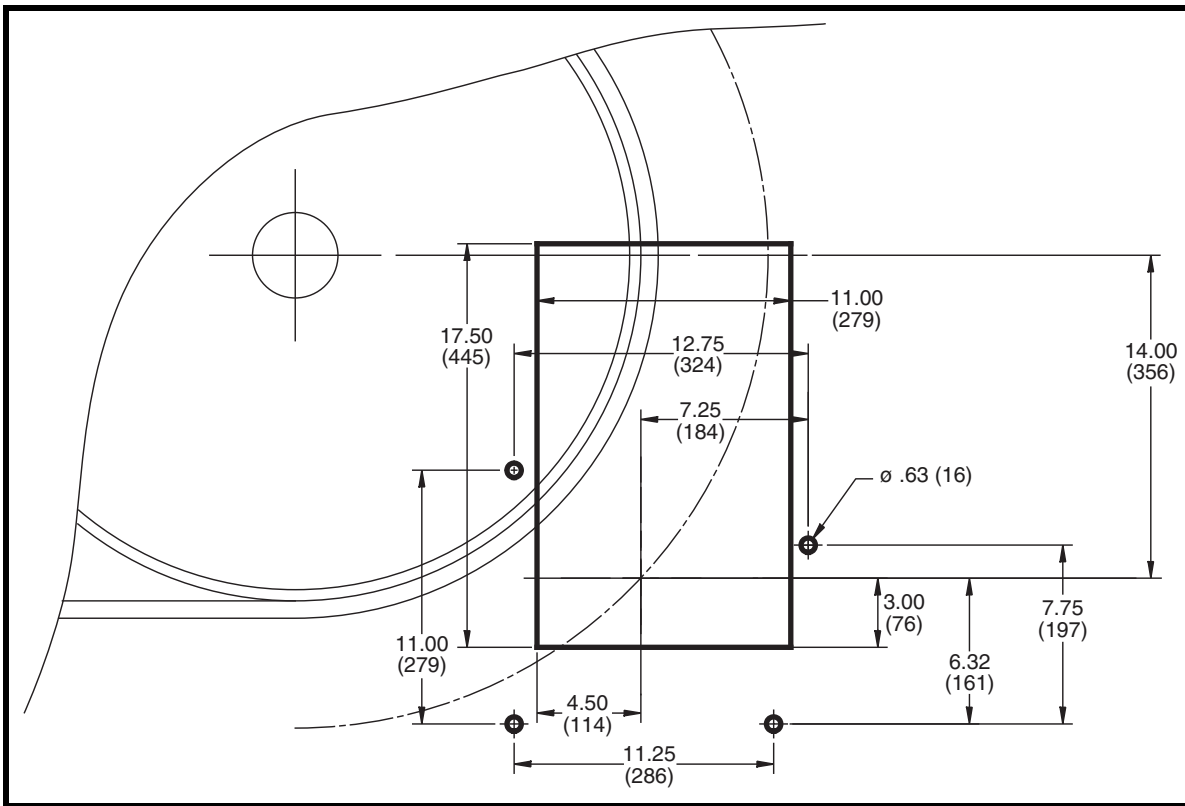

Figure 3. Operator Side Chute Cutout

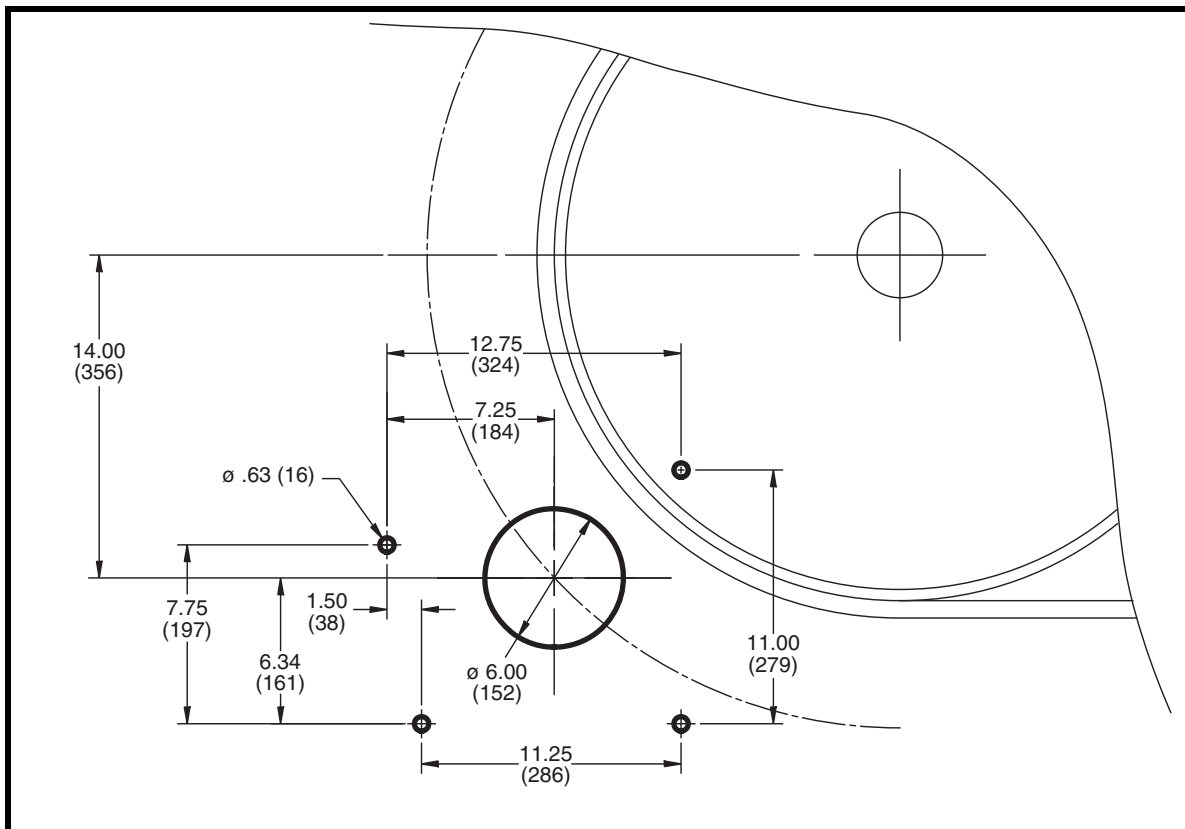

Figure 4. Far Side Chute Cutout

Marking Chute Cutouts

1. Using the previously marked lines, mark the operator side chute cutout and mount hole locations as shown in Figure 3. Mark the far side chute cutout and mount hole locations as shown in Figure 4.

NOTE

For easier maintenance, Martin Engineering recommends bolting rather than welding mount bracket to chute wall.

2. Bolt or weld tensioner mount bracket to chute wall as follows:
 - a. If bolting mount bracket to chute wall, do the following:
 - (1) Drill or cut four 5/8-in. holes in operator side chute wall. Remove burrs and sharp edges.
 - (2) Install mount bracket on chute wall with four hex head cap screws, flat washers, compression washers, and hex nuts (M).
 - b. If welding mount bracket to chute wall, do the following:
 - (1) Position mount bracket on chute wall so that four mounting holes line up with four holes marked on chute wall.
 - (2) Weld mount bracket onto chute wall. Skip weld around entire mount bracket surface contacting chute wall.
3. Mount the tensioners to the chute.

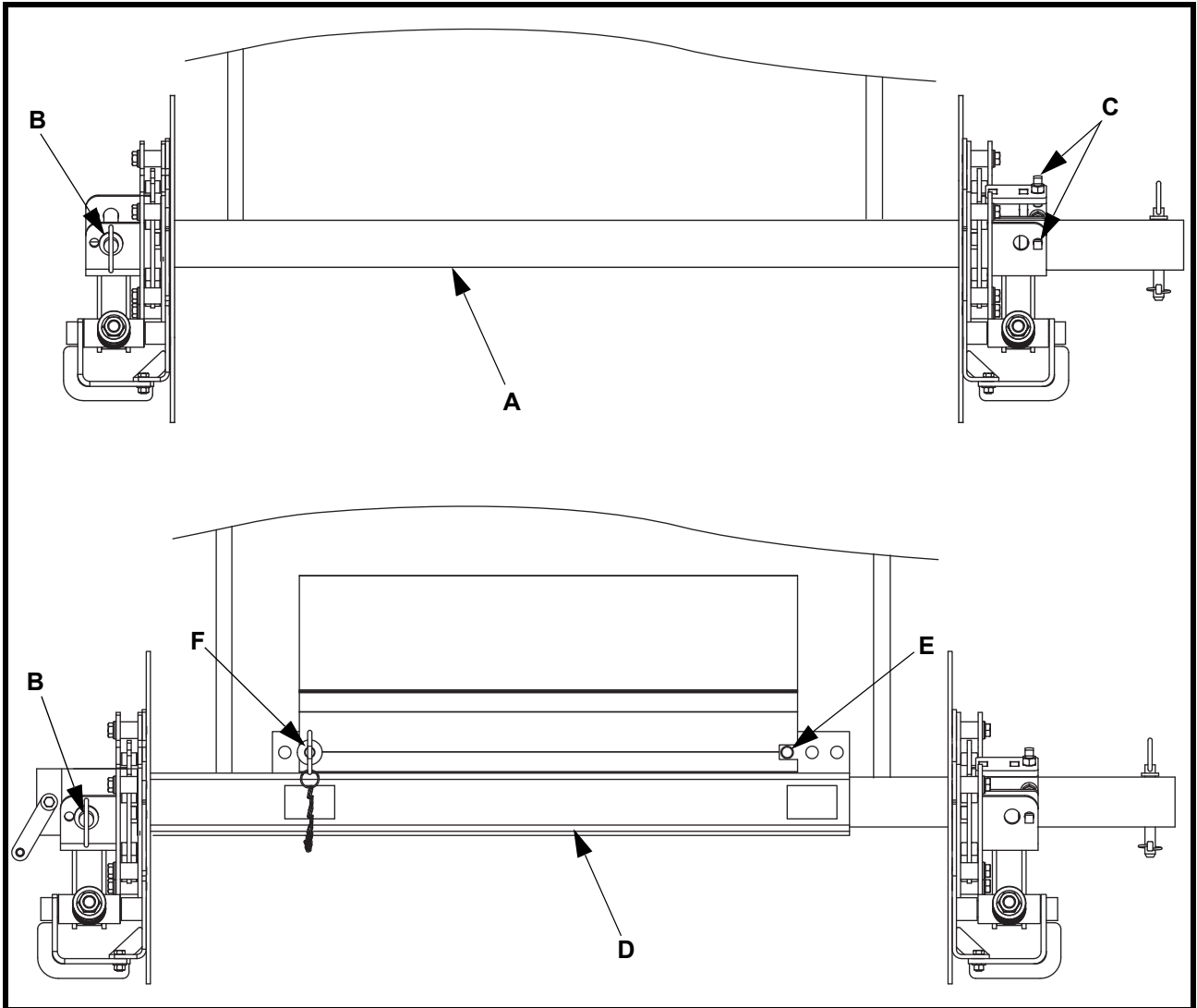

Figure 5. Installing Belt Cleaner

Installing Belt Cleaner

1. Install mandrel (A) into tensioners.
2. Insert pin (B) to hold mandrel in place.
3. Tighten set screws (C).
4. If necessary, cut excess mandrel from far side.
5. Remove pin (B).
6. Slide cartridge with blade (D) onto mandrel.
7. Insert pin (B) through operator side tensioner, cartridge (D) and mandrel (A).
8. Make sure blade is centered on belt and mainframe is parallel to belt.
9. If necessary, change location of pins (E and F) to center blade on belt.

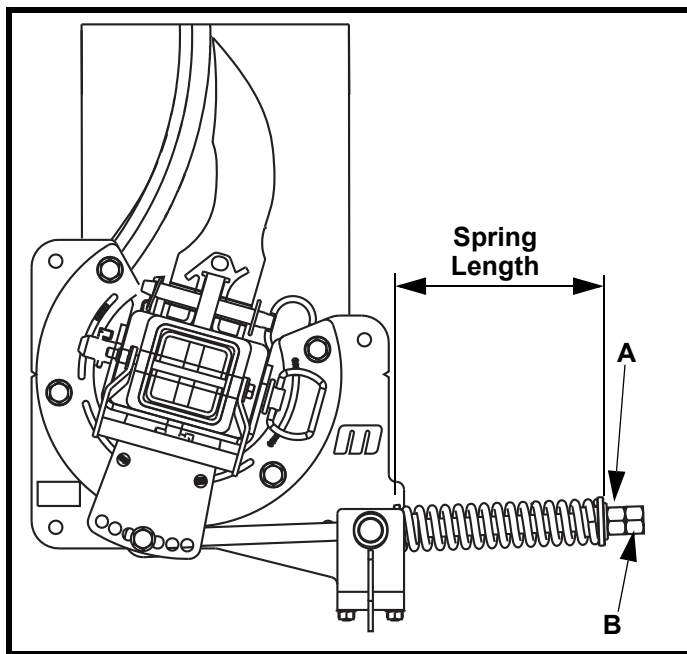

Figure 6. Adjusting Tensioner

Adjusting Spring Tensioner

1. Tighten tensioning nut (A) to compress spring to desired setting.
2. Install jam nut (B).
3. Lock tensioning nut and jam nut together.
4. Repeat steps 1–3 on far side tensioner.

Table III. Spring Tensioner Settings

Belt Width in. (mm)	Compressed Spring Length in. (mm)
36 (800–1000)	5.625 (143)
42 (1000–1200)	5.375 (137)
48 (1200–1400)	5.00 (127)
54 (1400–1600)	6.15 (156)

Belt Width in. (mm)	Compressed Spring Length in. (mm)
60 (1600–1800)	6.15 (156)
66 (1600–1800)	6.15 (156)
72 (1800–2000)	5.65 (144)
78 (1800–2000)	5.53 (140)

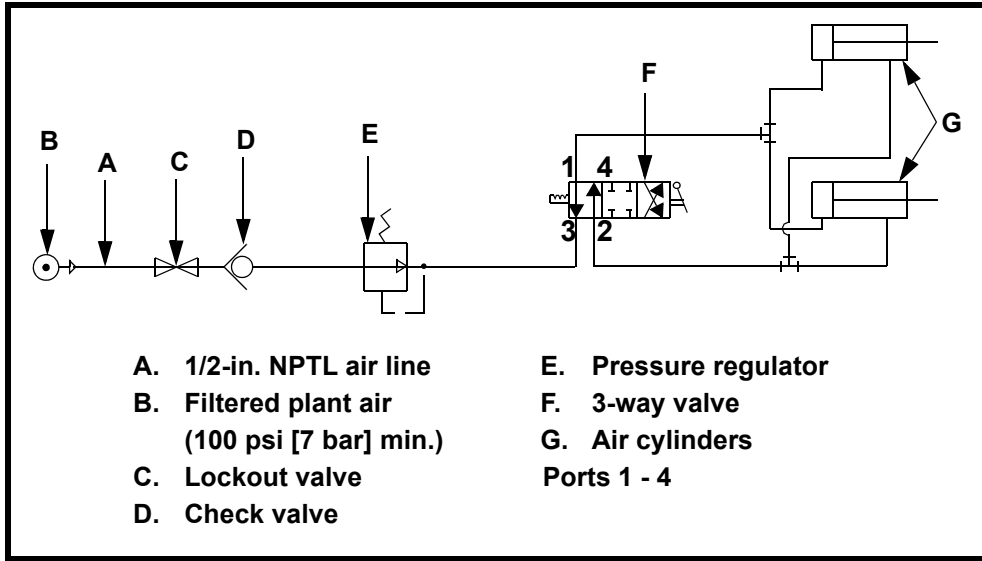

Figure 7. Air Cylinder Schematic

Installing Air Cylinder Tensioner

1. Install air line to air tensioner as shown in Figure 7.

IMPORTANT

Make sure you install air line into same port location on far side cylinder as on operator side cylinder.

- a. Install air line from port 1 on 3-way valve into one of two ports on air cylinder (G). Route air line to far side and install in same port on far side air cylinder.
- b. Install air line from port 2 on 3-way valve into unused port on air cylinder. Route air line to far side and install in same port on far side air cylinder.

CAUTION

Do not apply pressures greater than those recommended in Table IV. Higher pressures can damage conveyor belt or cleaner, and blades will wear faster.

2. Apply air pressure to air tensioner(s) according to Table IV.

Table IV. Air Cylinder Tensioner Settings

Belt Width in. (mm)	Air Pressure psi (bar)
24 (500–650)	12 (0.83)
30 (650–800)	16 (1.10)
36 (800–1000)	20 (1.38)
42 (1000–1200)	24 (1.65)
48 (1200–1400)	28 (1.93)

Belt Width in. (mm)	Air Pressure psi (bar)
54 (1400–1600)	32 (2.20)
60 (1600–1800)	36 (2.48)
66 (1600–1800)	40 (2.75)
72 (1800–2000)	44 (3.03)
78 (1800–2000)	48 (3.30)

After Installing Belt Cleaner



1. Thoroughly wipe chute wall clean above tensioner.
2. Place Conveyor Products Warning Label (P/N 23395) on outside chute wall visible to belt cleaner operator.

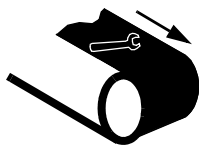

⚠ WARNING

Failure to remove tools from installation area and conveyor belt before turning on energy source can cause serious injury to personnel and damage to belt.



⚠ DANGER

Do not touch or go near conveyor belt or conveyor accessories when conveyor belt is running. Body or clothing can get caught and pull body into conveyor belt, causing severe injury or death.

3. Turn on conveyor belt for 1 hour, then turn off.



⚠ DANGER

Before installing, servicing, or adjusting the belt cleaner, turn off and lockout / tagout / blockout / testout all energy sources to the conveyor and conveyor accessories according to ANSI standards. Failure to do so could result in serious injury or death.

4. Make sure all fasteners are tight. Tighten if necessary.
5. Inspect belt cleaner for the following:
 - Wear. (A small amount of “break-in” wear may be found. This will stop once blades wear to conveyor belt contour.)
 - Material buildup. (No material between blades and return side of conveyor belt should be found.)
6. If wear, material buildup, or some other problem exists, see “Troubleshooting.”

Maintenance

NOTE

Maintenance inspections should be performed weekly until a maintenance schedule can be determined. Certain applications and/or changing material conditions may require more frequent maintenance inspections.



⚠ DANGER

Before installing, servicing, or adjusting the belt cleaner, turn off and lockout / tagout / blockout / testout all energy sources to the conveyor and conveyor accessories according to ANSI standards. Failure to do so could result in serious injury or death.

1. Remove any material from belt cleaner.
2. Make sure all fasteners are tight. Tighten if necessary.
3. Check tension on cleaner. Re-tension if necessary.
4. Wipe all labels clean. If labels are not readable, contact Martin Engineering or a representative for replacements.
5. Check blades for excessive wear. Replace if necessary.
6. Remove equipment from service if there is any indication it is not functioning properly. Call Martin Engineering or a representative for assistance. Do NOT return equipment to operation until the cause of the problem has been identified and corrected.

Blade Servicing

1. Undo tensioner and visually inspect blades.
 - a. If blades are clean and not excessively worn, re-tension cleaner.
 - b. If material buildup is still present or blades are worn excessively, proceed.

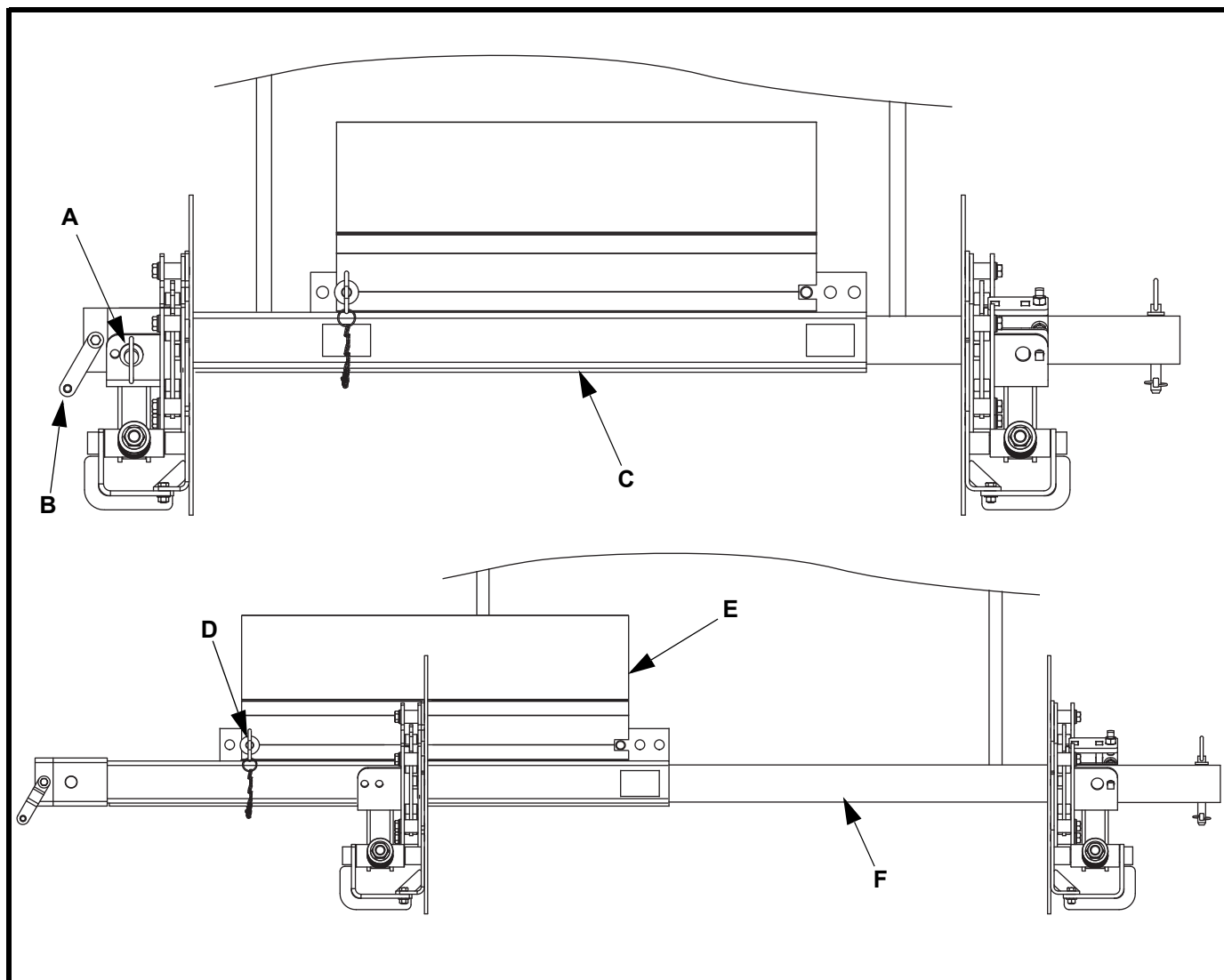
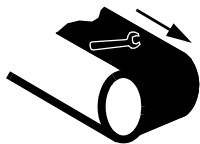

Figure 8. Blade Replacement

2. Release tension on each side of cleaner.
3. Remove pin (A).
4. Using handle (B) pull cartridge (C) outside the chute just far enough to remove pin (D).
5. Remove blade (E).
6. Replace blade and install pin (D).
7. Slide cartridge (C) back into place.
8. Insert pin (A) through operator side tensioner, cartridge (C) and mandrel (F).
9. Re-tension the cleaner.



⚠ WARNING

Failure to remove tools from installation area and conveyor belt before turning on energy source can cause serious injury to personnel and damage to belt.

10. Remove all tools from maintenance area.

⚠ DANGER

Do not touch or go near conveyor belt or conveyor accessories when conveyor belt is running. Body or clothing can get caught and pull body into conveyor belt, causing severe injury or death.

11. Start conveyor belt.



Troubleshooting

Symptom	Corrective Action
Insufficient cleaning and carryback.	<ul style="list-style-type: none"> • Tension of cleaner on belt is set too low or too high. Increase or decrease tensioner setting. • Blades are worn. Check blades and replace if necessary.
Noise or vibration.	Tension is not sufficient or is set too high. Correct tension as necessary. If this does not correct problem, blade urethane may not match application. Contact Martin Engineering or representative.
High blade wear rate.	Tension of cleaner on belt is set too high. Reduce tensioner setting.
Unusual wear or damage to blades.	Check belt splice(s) and repair as necessary.
Bent or broken mainframe or support frame due to blade slipping through.	If blades are worn to or past the wear line, replace blades. If blades are not worn, check mainframe location.
Corrosion or chemical degradation.	Blade urethane may not match application. Contact Martin Engineering or representative.

NOTE

Conveyor equipment such as conveyor belt cleaners are subject to a wide variety of bulk materials characteristics and often have to perform under extreme operating or environmental conditions. It is not possible to predict all circumstances that may require troubleshooting. Contact Martin Engineering or a representative if you are experiencing problems other than those listed in the “Troubleshooting” chart above. Do not return the equipment to operation until the problem has been identified and corrected.

Installation checklist

If after taking the corrective actions suggested under “Troubleshooting” you are still experiencing problems, check for the following:

Installation Checklist
• Pre-Cleaner mainframe is proper distance from belt surface on both ends of mainframe.
• Pre-Cleaner blade tip is at or below horizontal center line of pulley and does not lie in path of material flow.
• Blades are centered on belt.

Part Numbers

This section provides product names and corresponding part numbers for Martin® QC1™ Cleaner XHD STS™ and related equipment. Please reference part numbers when ordering parts:

**Martin® QC1™
Cleaner XHD
STS™**

NOMENCLATURE

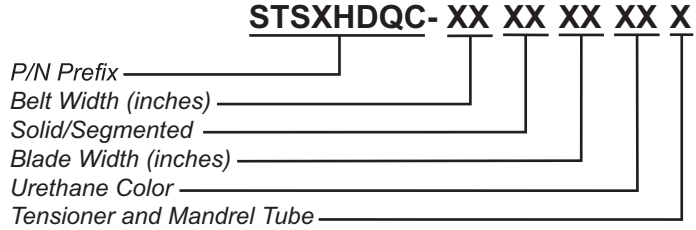

SOLID/SEGMENTED

- 11:** no slits or segments
- 10:** segments only

TENSIONER

- T:** Spring Tensioner
- A:** Air Tensioner
- Blank:** No Tensioner or Mandrel Tube

URETHANE COLOR

- BR:** Brown
- CL:** Tan
- GR:** Green
- NB:** Navy Blue
- CY:** Yellow with Beads
- Blank:** Orange

Tensioners

Martin® Spring Tensioner XHD STS™: P/N 39100-XHDSXSQ

Martin® Air Cylinder Tensioner XHD STS™: P/N 39100-XHDASQ

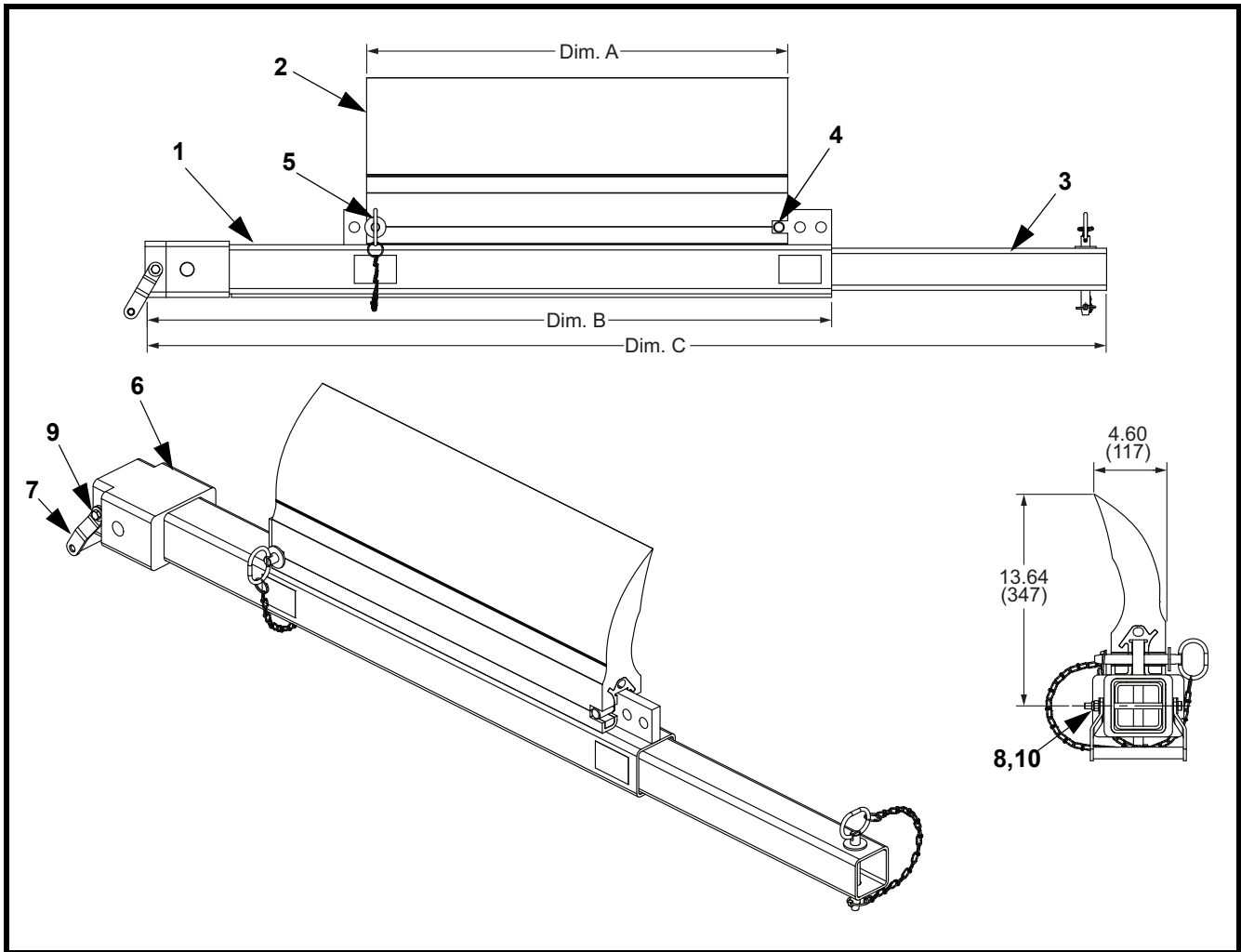

Figure 9. Martin® QC1™ Cleaner XHD STS™ Assembly, P/N STSXHDQC-XXXXXXXXX

Item	Description	Part no.	Qty
1	Mainframe Weldment	39239-XX*	1
2	Blade	Table V	1
3	Mandrel Weldment	37802-XX*	1
4	Knurled Pin 3/4 Dia. ZP	36046	1
5	Pin Hitch 5/8 x 4 with Lynch Pin	36976	1
6	End Cap	37805	1
7	Handle Weldment	37211	1
8	Washer Flat 3/8 wide ZP	18007	2
9	Screw HHC 3/8-16NC x 6 ZP	37834	1
10	Nut Hex Elastic Lock 3/8-16NC ZP	14201	1
NS	Label Martin® Product	38048	2
NS	Tensioner	Fig. 10 or Fig. 11	1
NS	Operator's Manual	M3987	1
NS	Label Conveyor Products Warning	23395	2

*XX indicates belt width.

NS = Not Shown

Table V. Martin® QC1™ Cleaner XHD STS™ Assembly Part Numbers

Part No.	Dim A Blade Length	Dim B Frame Length	Dim C Frame Length	Part No. Item 2
STSHDQC-24XX12XXX	12.00 (305)	36.91 (938)	56.50 (1435)	C1QCEBS24SCXX
STSHDQC-24XX18XXX	18.00 (457)	36.91 (938)	56.50 (1435)	C1QCEBS24S6XX
STSHDQC-30XX18XXX	18.00 (457)	42.91 (1090)	62.50 (1588)	C1QCEBS30SCXX
STSHDQC-30XX24XXX	24.00 (610)	42.91 (1090)	62.50 (1588)	C1QCEBS30S6XX
STSHDQC-36XX24XXX	24.00 (610)	48.91 (1242)	68.50 (1740)	C1QCEBS36SCXX
STSHDQC-36XX30XXX	30.00 (762)	48.91 (1242)	68.50 (1740)	C1QCEBS36S6XX
STSHDQC-42XX30XXX	30.00 (762)	54.91 (1395)	74.50 (1892)	C1QCEBS42SCXX
STSHDQC-42XX36XXX	36.00 (914)	54.91 (1395)	74.50 (1892)	C1QCEBS42S6XX
STSHDQC-48XX36XXX	36.00 (914)	60.91 (1547)	80.50 (2045)	C1QCEBS48SCXX
STSHDQC-48XX42XXX	42.00 (1067)	60.91 (1547)	80.50 (2045)	C1QCEBS48S6XX
STSHDQC-54XX36XXX	36.00 (914)	66.91 (1700)	86.50 (2197)	C1QCEBS48SCXX
STSHDQC-54XX42XXX	42.00 (1067)	66.91 (1700)	86.50 (2197)	C1QCEBS54SCXX
STSHDQC-54XX48XXX	48.00 (1219)	66.91 (1700)	86.50 (2197)	C1QCEBS54S6XX
STSHDQC-60XX42XXX	42.00 (1067)	72.91 (1852)	92.50 (2350)	C1QCEBS54SCXX
STSHDQC-60XX48XXX	48.00 (1219)	72.91 (1852)	92.50 (2350)	C1QCEBS60SCXX
STSHDQC-60XX54XXX	54.00 (1372)	72.91 (1852)	92.50 (2350)	C1QCEBS60S6XX
STSHDQC-66XX48XXX	48.00 (1219)	78.91 (2004)	98.50 (2502)	C1QCEBS60SCXX
STSHDQC-66XX54XXX	54.00 (1372)	78.91 (2004)	98.50 (2502)	C1QCEBS66SCXX
STSHDQC-66XX60XXX	60.00 (1524)	78.91 (2004)	98.50 (2502)	C1QCEBS66S6XX
STSHDQC-72XX54XXX	54.00 (1372)	84.91 (2157)	104.50 (2654)	C1QCEBS66SCXX
STSHDQC-72XX60XXX	60.00 (1524)	84.91 (2157)	104.50 (2654)	C1QCEBS72S6XX
STSHDQC-72XX66XXX	66.00 (1676)	84.91 (2157)	104.50 (2654)	C1QCEBS66SCXX
STSHDQC-78XX60XXX	60.00 (1524)	90.91 (2309)	110.50 (2807)	C1QCEBS72SCXX
STSHDQC-78XX66XXX	66.00 (1676)	90.91 (2309)	110.50 (2807)	C1QCEBS78SCXX

Table VI. Martin® QC1™ Blade XHD

Assembly Part No.	Color
STSHDQC-XXXXXXX	Orange
STSHDQC-XXXXXXBRX	Brown
STSHDQC-XXXXXXCLX	Clear
STSHDQC-XXXXXXGRX	Green
STSHDQC-XXXXXXNBX	Navy Blue
STSHDQC-XXXXXXCYX	Yellow with Ceramic Beads

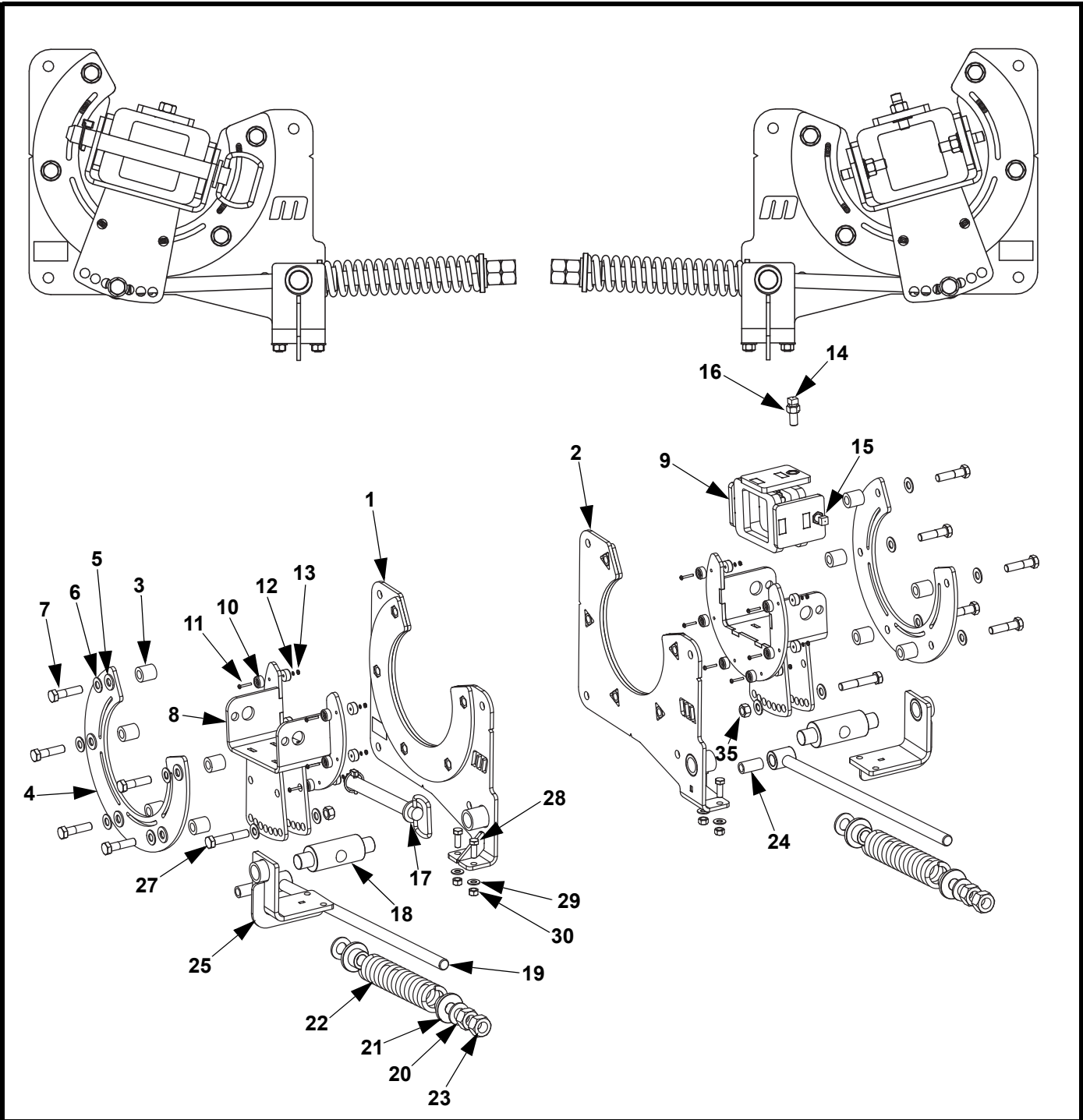

Figure 10. Martin® Spring Tensioner XHD STS™, P/N 39100-XHDSXSQ

Item	Description	Part no.	Qty
1	Operator Side Mount Weldment	39094-RA	1
2	Far Side Mount Weldment	39094-LA	1
3	Spacer Tube	39097	10
4	Slider Outer Ring	39098-A	2

Item	Description	Part no.	Qty
5	Washer Flat 1/2 Narrow SS	17152	10
6	Washer Compression 1/2 SS	24310	14
7	Screw HHC 1/2-13NC x 2 SS	24308	10
8	Saddle Pivot Weldment	39093-ASQ	2
9	Far Side Strap Weldment	39459	1
10	Plastic Bumper	39092	24
11	Screw SPHM #6-32 x 7/8 SS	39136	12
12	Washer Lock Helical Spring #6 SS	39137	12
13	Nut Hex Undersized Mach #6-32 SS	39138	12
14	Screw SHS 1/2-13NC x 1-1/2 SS	33190	1
15	Screw SHS 1/2-13NC x 2 SS	22763-06	2
16	Nut Hex 1/2-13NC SS	17151	3
17	Pin Hitch 7/8 x 7.00	37818	1
18	Spring Stop	39377-01	2
19	Threaded Rod Weldment	39377XHD-03	2
20	Washer Flat 3/4 Military Spec SS	16223	4
21	Spring Guide	Table VII	4
22	Spring Compression	Table VII	2
23	Nut Hex 3/4-6 ACME 304 SS	38170-SS	4
24	Air Cylinder Rod Eye Tube	39094-6A	2
25	Air Cylinder Trunnion Mount Angle Weldment	39094-12A	2
26 (NS)	Label Martin® Product	32238	2
27	Screw HHC 1/2-13NC x 2-3/4 SS	26155	2
28	Screw HHC 3/8-16NC x 1 SS	11461	4
29	Washer Compression 3/8 SS	28565	4
30	Nut Hex 3/8-16NC SS	16054	4
31 (NS)	Label Conveyor Products Warning	23395	2
32 (NS)	Mounting Hardware	38228-SS	1
33 (NS)	Operator's Manual	M3987	1
34 (NS)	Label Tensioning	39438-S	1
35	Nut Hex Elastic Lock 1/2-13NC SS	24307	2

Figure 10. Martin® Spring Tensioner XHD STS™, P/N 39100-XHDSXSQ

Table VII. Martin® Spring Tensioner XHD STS™ Part Numbers

Assembly Part No.	Belt Width	P/N Item 21	P/N Item 22
39100-XHDS1SQ	24–48	39377XHD-041	39377XHD-SPR120
39100-XHDS2SQ	54–120	39377XHD-042	39377XHD-SPR260

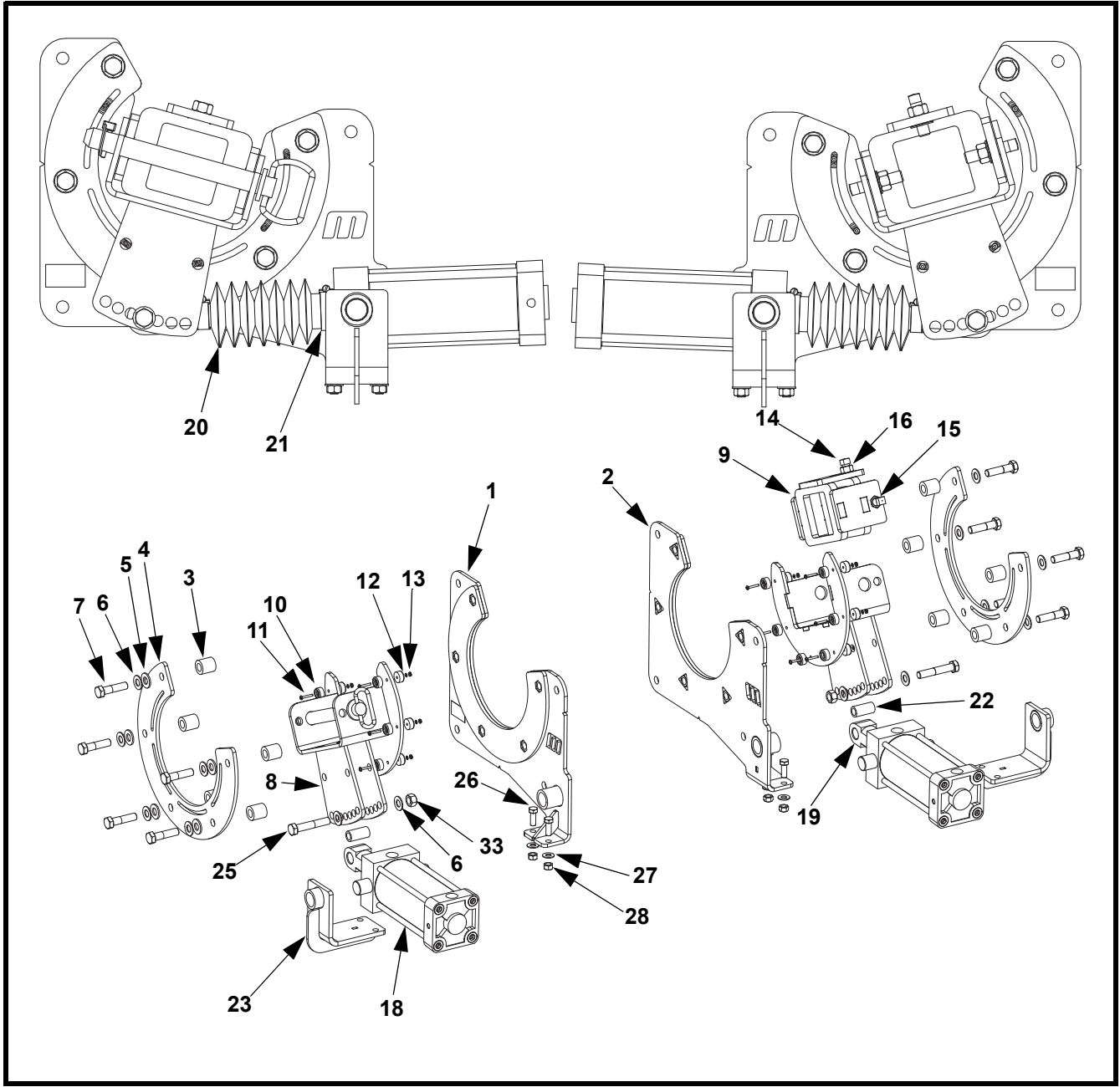

Figure 11. Martin® Air Cylinder Tensioner XHD STS™, P/N 39100-XHDASQ

Item	Description	Part no.	Qty
1	Operator Side Mount Weldment	39094-RA	1
2	Far Side Mount Weldment	39094-LA	1
3	Spacer Tube	39097	10
4	Slider Outer Ring	39098-A	2
5	Washer Flat 1/2 Narrow SS	17152	10
6	Washer Compression 1/2 SS	24310	14
7	Screw HHC 1/2-13NC x 2 SS	24308	10
8	Saddle Pivot Weldment	39093-ASQ	2
9	Far Side Strap Weldment	39459	1
10	Plastic Bumper	39092	24
11	Screw SPM #6-32 x 7/8 SS	39136	12
12	Washer Lock Helical Spring #6 SS	39137	12
13	Nut Hex Undersized Mach #6-32 SS	39138	12
14	Screw SHS 1/2-13NC x 1-1/2 SS	33190	1
15	Screw SHS 1/2-13NC x 2 SS	22763-06	2
16	Nut Hex 1/2-13NC SS	17151	3
17	Pin Hitch 7/8 x 7.00	37818	1
18	Air Cylinder 3.25 Bore x 5.00 Stroke	32130-2	2
19	Air Cylinder Rod Eye 3/4-16NF	32131-2	2
20	Rod Boot	32132	2
21	Worm Drive Hose Clamp	20339-06	4
22	Air Cylinder Rod Eye Tube	39094-6A	2
23	Trunnion Mount Angle Weldment	39094-12A	2
24 (NS)	Label Martin® Product	32238	2
25	Screw HHC 1/2-13NC x 2-3/4 SS	26155	2
26	Screw HHC 3/8-16NC x 1 SS	11461	4
27	Washer Compression 3/8 SS	28565	4
28	Nut Hex 3/8-16NC SS	16054	4
29 (NS)	Label Conveyor Products Warning	23395	2
30 (NS)	Mounting Hardware	38228-SS	1
31 (NS)	Operator's Manual	M3987	1
32 (NS)	Label Tensioning	39438-A	1
33	Nut Hex Elastic Lock 1/2-13NC SS	24307	2

Figure 11. Martin® Air Cylinder Tensioner XHD STS™, P/N 39100-XHDASQ

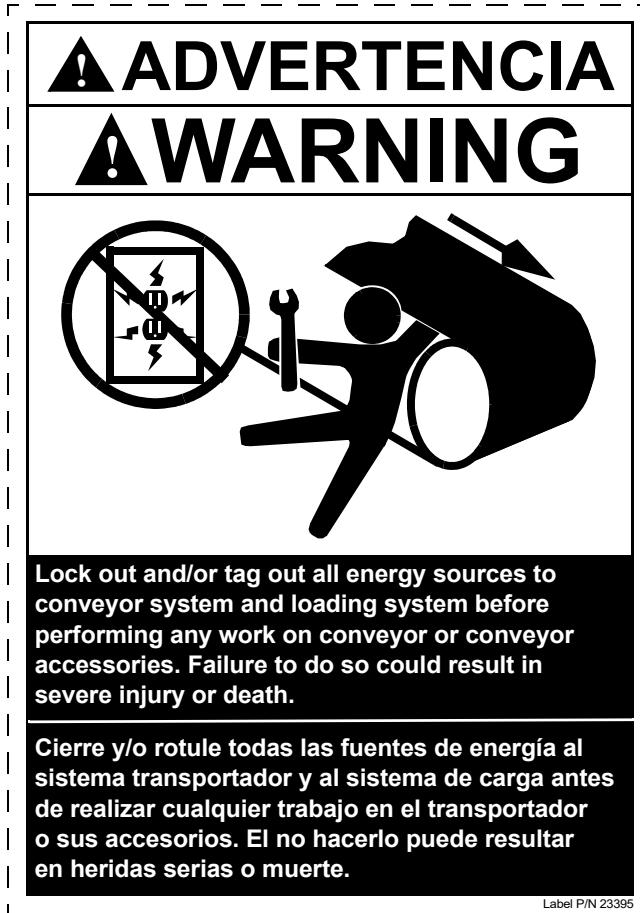

Figure 12. Martin® Conveyor Products Warning Label, P/N 23395



Figure 13. Martin® Pinch Point Warning Label, P/N 30528

**Martin® Spring Tensioner XHD STS
Recommended Tension**

Belt Width		Compressed Spring Length*	
in.	(mm)	in.	(mm)
36	(800-1000)	5.625	(143)
42	(1000-1200)	5.375	(137)
48	(1200-1400)	5.00	(127)
54	(1400-1600)	6.15	(156)
60	(1600-1800)	6.15	(156)
66	(1600-1800)	6.15	(156)
72	(1800-2000)	5.65	(144)
78	(1800-2000)	5.53	(140)

*Per tensioner. Dual tensioners required.



800-544-2947
or 309-852-2384
www.martin-eng.com

Place label on chute wall,
visible to tensioner user.

Label P/N 39438-S

Figure 14. Martin® Spring Tensioner XHD STS™ Tensioning Label, P/N 39438-S

**Martin® Air Tensioner XHD STS
Recommended Pressure**

Belt Width		Air Pressure*	
in.	(mm)	psi	(bar)
24	(500-650)	12	(0.83)
30	(650-800)	16	(1.10)
36	(800-1000)	20	(1.38)
42	(1000-1200)	24	(1.65)
48	(1200-1400)	28	(1.93)
54	(1400-1600)	32	(2.20)
60	(1600-1800)	36	(2.48)
66	(1600-1800)	40	(2.75)
72	(1800-2000)	44	(3.03)
78	(1800-2000)	48	(3.30)

*Per tensioner. Dual tensioners required.



800-544-2947
or 309-852-2384
www.martin-eng.com

Place label on chute wall,
visible to tensioner user.

Label P/N 39438-A

Figure 15. Martin® Air Tensioner XHD STS™ Tensioning Label, P/N 39438-A

Any product, process, or technology described here may be the subject of intellectual property rights reserved by Martin Engineering Company. Trademarks or service marks designated with the ® symbol are registered with the U.S. Patent and Trademark Office and may be proprietary in one or more countries or regions. Other trademarks and service marks belonging to Martin Engineering Company in the United States and/or other countries or regions may be designated with the “TM” and “SM” symbols. Brands, trademarks, and names of other parties, who may or may not be affiliated with, connected to, or endorsed by Martin Engineering Company, are identified wherever possible. Additional information regarding Martin Engineering Company’s intellectual property can be obtained at www.martin-eng.com/trademarks.

Problem Solved™ ***GUARANTEED!***

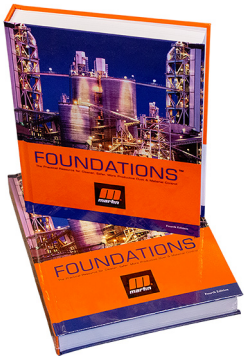

For nearly 30 years, Martin Engineering's Foundations™ Books have taught industry personnel to operate and maintain clean and safe belt conveyors. The Foundations™ Book, fourth edition, focuses on improving belt conveyors by controlling fugitive material. "The Practical Resource for Total Dust and Material Control," is a 576-page hard cover volume that provides information of value to industries where the efficient handling of bulk materials is a key to productivity and profitability.

Expanding upon the book, our Foundations™ Training Program addresses the design and development of more productive belt conveyors, and is offered in three customizable seminars. Attendees gain a better understanding of conveyor safety and performance, helping to justify upgrade investments and increase profitability.



Martin Engineering USA

One Martin Place
Neponset, IL 61345-9766 USA
800 544 2947 or 309 852 2384
Fax 800 814 1553
www.martin-eng.com

**COMPANY WITH
QUALITY SYSTEM
CERTIFIED BY DNV GL
= ISO 9001 =**