



# ***Martin® AP5 Series Piston Vibrators***

[Go to Martin® AP5 Series Piston Vibrators web page.](#)



***Operator's Manual  
M3898***

# Important

MARTIN ENGINEERING HEREBY DISCLAIMS ANY LIABILITY FOR: DAMAGE DUE TO CONTAMINATION OF THE MATERIAL; USER'S FAILURE TO INSPECT, MAINTAIN AND TAKE REASONABLE CARE OF THE EQUIPMENT; INJURIES OR DAMAGE RESULTING FROM USE OR APPLICATION OF THIS PRODUCT CONTRARY TO INSTRUCTIONS AND SPECIFICATIONS CONTAINED HEREIN. MARTIN ENGINEERING'S LIABILITY SHALL BE LIMITED TO REPAIR OR REPLACEMENT OF EQUIPMENT SHOWN TO BE DEFECTIVE.

Observe all safety rules given herein along with owner and Government standards and regulations. Know and understand lockout/tagout procedures as defined by American National Standards Institute (ANSI) ANSI/ASSP z244.1-2024, *The Control of Hazardous Energy Lockout, Tagout And Alternative Methods and Occupational Safety* and Health Administration (OSHA) Federal Register, Title 29 Subtitle B Chapter XVII Subpart J 1910.147, *Control of Hazardous Energy Source (Lockout/Tagout)*; Final Rule.

The following symbols may be used in this manual:



**Danger:** Immediate hazards that will result in severe personal injury or death.



**Warning:** Hazards or unsafe practices that could result in personal injury.



**Caution:** Hazards or unsafe practices that could result in product or property damages.



**Important:** Instructions that must be followed to ensure proper installation/operation of equipment.



**Note:** General statements to assist the reader.

# Table of Contents

Section	Page
List of Figures and Tables .....	ii
Introduction .....	1
General .....	1
References .....	1
Safety .....	1
Materials required .....	1
Before Installing Vibrator .....	2
Installing Vibrator .....	3
Locating vibrator on structure .....	4
Installing reinforcing beam onto structure .....	4
Mounting vibrator onto structure .....	6
Connecting air lines .....	8
After Installing Vibrator .....	9
Troubleshooting .....	9
Part Numbers .....	10
Appendix A. Martin® AP5 Series Piston Vibrator Specifications .....	A-1
Appendix B. Martin® AP5 Series Piston Vibrator Dimensions .....	B-1

## List of Figures

Figure	Title	Page
1	Locating Vibrator on Structure .....	4
2	Channel and TBM Wedge Mounts .....	5
3	Skip Weld .....	5
4	Mounting Vibrator without Spring .....	6
5	Installing Vibrator Safety Cable .....	7
6	Plumbing Detail for Normally-Closed Solenoid Valve .....	8
7	Martin® AP5 Series Piston Vibrator, P/N AP5-125XX-X .....	11
8	Martin® AP5 Series Piston Vibrator, P/N AP5-200XX-X .....	13
9	Martin® AP5 Series Piston Vibrator, P/N AP5-300XX-X .....	15
10	Martin® AP5 Series Piston Vibrator, P/N AP5-400XX-X .....	17

## List of Tables

Table	Title	Page
I	Martin® AP5 Series Piston Vibrator Selection for Bins and Hoppers .....	1
II	Bolt Sizes and Torque Specifications .....	6
III	Martin® AP5 Series Piston Vibrator Part Numbers and Quantities, P/N AP5-125XX-X .....	12
IV	Martin® AP5 Series Piston Vibrator Part Numbers and Quantities, P/N AP5-200XX-X .....	14
V	Martin® AP5 Series Piston Vibrator Part Numbers and Quantities, P/N AP5-300XX-X .....	16
VI	Martin® AP5 Series Piston Vibrator Part Numbers and Quantities, P/N AP5-400XX-X .....	18

# Introduction

## General

Martin® AP5 Series Piston Vibrators provide force to activate the free flow of sticky, coarse, high-moisture materials in bins and hoppers. The vibrators require no maintenance when used with filtered and lubricated air.

Vibrators are sized based on weight and characteristics of material in the sloped portion of bins and hoppers. Table I shows sizes of vibrators needed for applications using 1 lb of force for 10 lb of material (assuming the material can flow and weighs less than 100 lb per cubic foot). More force is needed for materials of high density or moisture.

**Table I. Martin® AP5 Series Piston Vibrator Selection for Bins and Hoppers**

Model	Qty	Weight of Material lb (kg)	Minimum Bin Wall Thickness in. (mm)	Channel Length in. (mm)
AP5-125	1	2900 (1315)	12 gauge to 1/8 (2.8 to 3.1)	18 (457)
AP5-125	2	5800 (2630)	3/16 to 1/4 (4.8 to 6.4)	18 (457)
AP5-200	1	4900 (2223)	3/16 to 1/4 (4.8 to 6.4)	24 (610)
AP5-200	2	9800 (4445)	1/4 to 3/8 (6.4 to 9.5)	24 (610)
AP5-300	1	9800 (4445)	1/4 to 3/8 (6.4 to 9.5)	36 (914)
AP5-300	2	19,600 (8890)	3/8 to 1/2 (9.5 to 12.7)	36 (914)
AP5-400	1	22,000 (9980)	3/8 to 1/2 (9.5 to 12.7)	72 (1829)
AP5-400	2	44,000 (19,960)	1/2 + (12.7 +)	72 (1829)

This manual covers installing and operating Martin® AP5 Series Piston Vibrators on bins, hoppers, and chutes. For assistance installing the vibrators for other applications, call Martin Engineering.

- Technical data is provided in Appendix A.
- Dimensions for each vibrator are provided in Appendix B.

## References

The following documents are referenced in this manual:

- American National Standards Institute ANSI/ASSP z244.1-2016 (R2020), *The Control Of Hazardous Energy Lockout, Tagout And Alternative Methods*, American National Standards Institute, Inc., 1430 Broadway, New York, NY 10018.
- Federal Register, Volume 54, Number 169, Part IV, 29 CFR Part 1910, *Control of Hazardous Energy Source (Lockout/Tagout); Final Rule*, Department of Labor, Occupational Safety and Health Administration (OSHA), 32nd Floor, Room 3244, 230 South Dearborn Street, Chicago, IL 60604.

## Safety

All safety rules in the above documents and all owner/employer safety rules must be strictly followed when working with this unit.

## Materials required:

In addition to standard hand tools, the following materials are required to install this equipment:

- Channel Mount, P/N 29928-XX or equivalent.
- Filter, Regulator, Lubricator, P/N 14760.
- Safety Catble Kit, P/N 32271.

## Before Installing Vibrator

---

### IMPORTANT

The delivery service is responsible for damage incurred during transportation. Martin Engineering CANNOT enter claims for damage. Contact your transportation agent for information.

1. Inspect shipping container for damage. Report damage to delivery service immediately and fill out delivery service's claim form. Keep any damaged goods subject to examination.
2. Remove vibrator from shipping container.
3. If anything is missing or damaged, contact Martin Engineering or a representative.



### WARNING

Before installing equipment, turn off and lock out/tag out energy source to conveyor and conveyor accessories.

4. Turn off and lock out/tag out energy source according to ANSI standards (see "References").

### WARNING

If equipment will be installed in an enclosed area, gas level or dust content must be tested before using a cutting torch or welding. Using a cutting torch or welding in an area with gas or dust may cause an explosion.

5. If using a cutting torch or welding, test atmosphere for gas level or dust content. Cover conveyor belt with fire retardant cover.
6. Make sure mounting surface is strong and flat, within 1/32 in. (1.2 mm) across vibrator feet. (This will prevent internal stress to vibrator casting when tightening mount bolts.)
7. Make sure mounting surface and vibrator are clean and free of debris.



## IMPORTANT

Read entire section before beginning work.

## ⚠ CAUTION

**If installation instructions are not followed, structure and vibrator can be damaged. Abusing or handling vibrator carelessly will accelerate wear and shorten bearing life.**

To install the Martin® AP5 Series Piston Vibrator, follow the procedures corresponding to the following steps:

1. Determine where to locate the vibrator on the structure.

## IMPORTANT

**For material to flow efficiently, it is important that the vibration be distributed throughout the application. The more rigid and firm the mount, the more effective and efficient the vibrator will perform. A weak mount will hamper the distribution of vibration, lower the vibrator's efficiency, and possibly result in vibrator failure and/or fatigue of the application.**

## IMPORTANT

**Piston vibrators produce linear vibration best applied to wet, sticky material adhering to a bin wall. The object is to move the wall back and forth to dislodge the material.**

2. Install 1.5- to 6-ft (457- to 1829-mm) channel or beam onto sloped section of bin.
3. Install channel mount or equivalent onto structure or beam reinforcement, as applicable.
4. Mount vibrator to structure.
5. Connect lubricated air lines to vibrator.

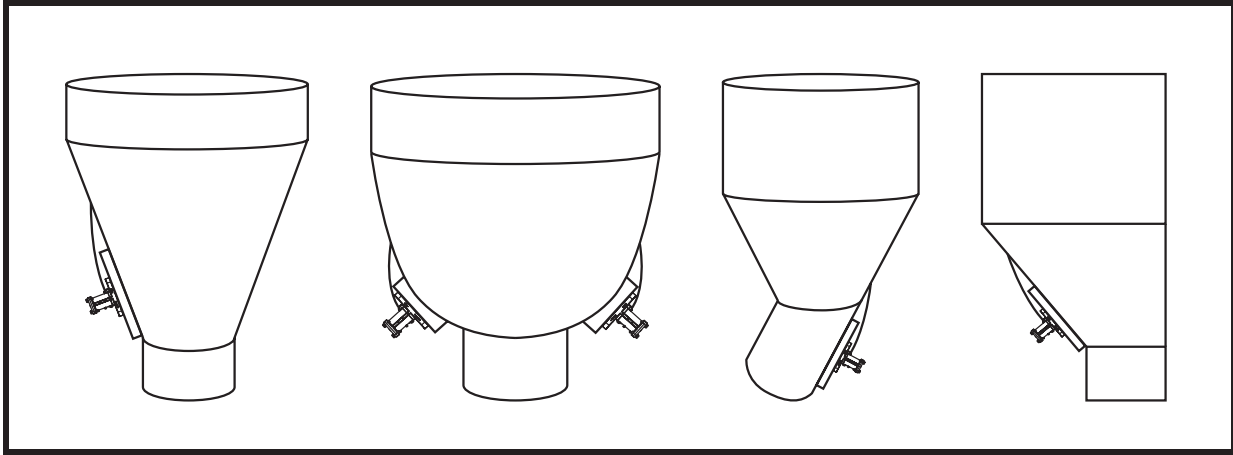

**Figure 1. Locating Vibrator on Structure**

***Locating vibrator on structure***

See Figure 1. Locate vibrator in lower 1/4 of structure slope length. If second vibrator is required, mount 180 degrees from first vibrator and 1/3 up slope.

**NOTE**

***Installing reinforcing beam onto structure***

**This section provides instructions for installing vibrator on steel structure. To install vibrator on concrete structure, contact Martin Engineering for instructions.**

1. If using customer-supplied mounting plate to mount vibrator onto structure, do the following:
  - a. Make sure plate is at least the size of vibrator base.
  - b. Locate plate so that vibrator can be positioned as shown in Figure 1.
  - c. Weld mounting plate onto structure.
2. See Figure 2. If using Martin® Channel Mount to mount vibrator onto structure, do the following:
  - a. Locate mount so that vibrator can be positioned as shown in Figure 1.
  - b. Install 1.5- to 6-ft (457- to 1829-mm) channel or beam onto chute wall.

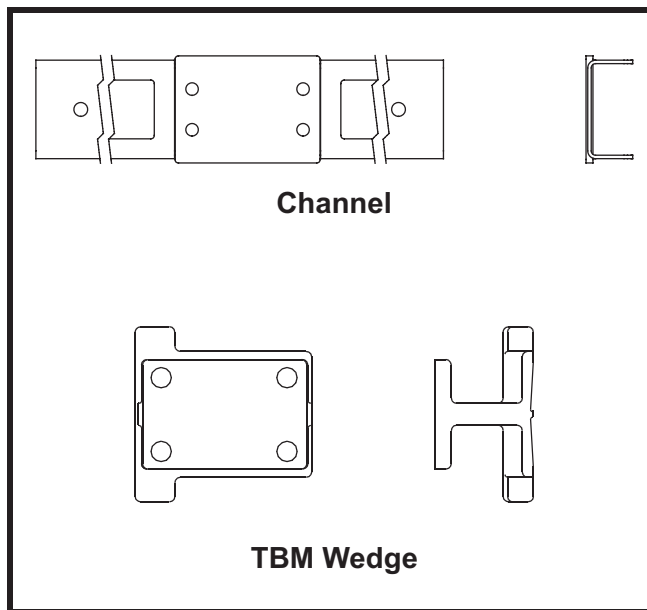

**Figure 2. Channel and TBM Wedge Mounts (Top and Side Views)**

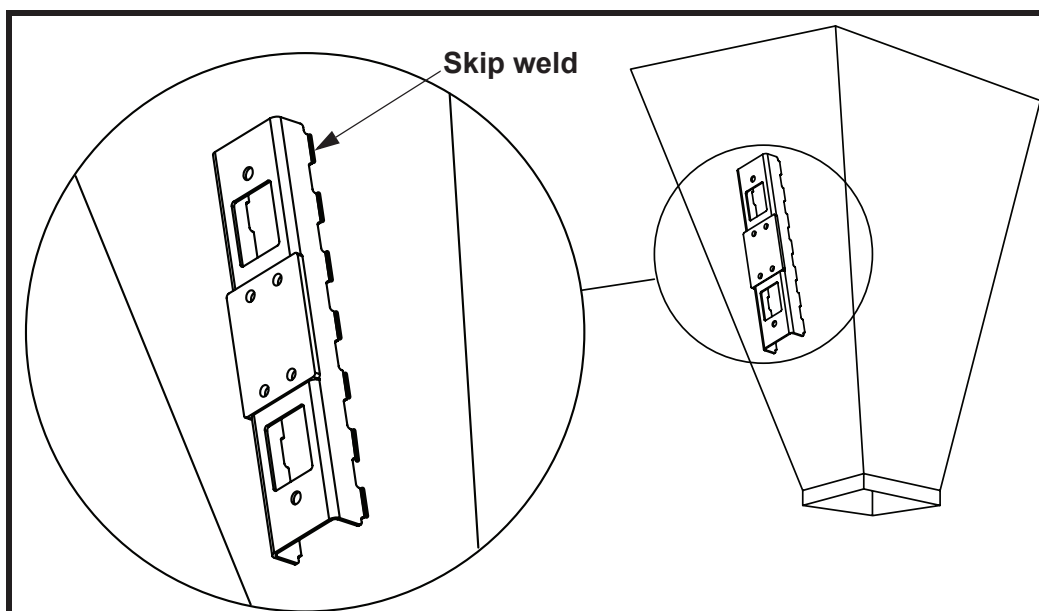

**Figure 3. Skip Weld**

- c. See Figure 3. Skip-weld beam in place: Weld tabs of channel to hopper wall. Repeat for entire perimeter of beam. Do not weld last 1 in. (25 mm) of either end of beam or any corner.
- d. If installing vibrator on hopper with wedge mount already in place, use TBM Wedge (see Figure 2) or equivalent to mount vibrator. Mount female half of wedge rigidly to beam extending at least 3/4 the slope length.

*Mounting vibrator onto structure*

**▲ WARNING**

Move vibrator into final position carefully. Sudden movements could cause piston to fall out of vibrator body causing damage to piston or injury to personnel.

**IMPORTANT**

If vibrator has been partially disassembled, make sure piston is reinserted correctly.

AP5 Series vibrator without spring must be mounted with a minimum slope of 15° below horizontal. (See Figure 4.)

1. If using vibrator without spring, ensure mounting location has a minimum slope of 15° below horizontal. (See Figure 4.)

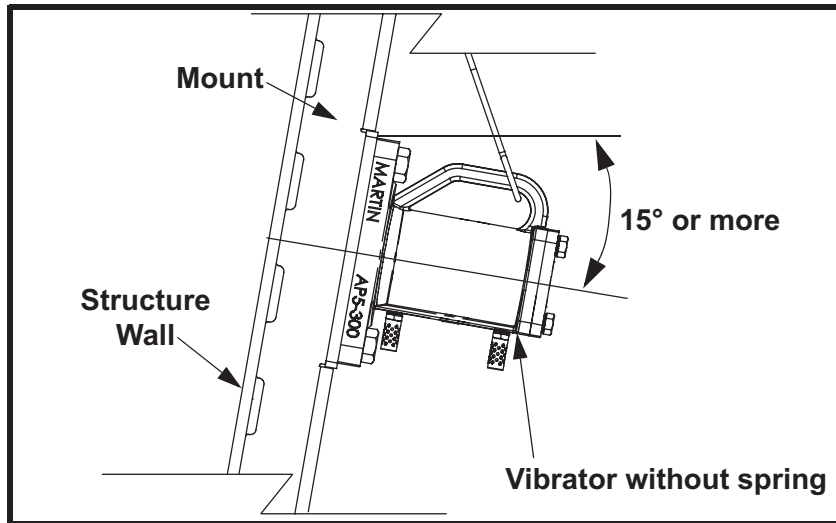

Figure 4. Mounting Vibrator without Spring

**▲ CAUTION**

Use only new bolts, lock nuts, and compression washers to install vibrator. Old fasteners can break and cause damage to vibrator or structure.

2. Install vibrator onto Channel mount or TBM wedge (see Figure 2) as follows:
  - a. Align mounting holes in vibrator with mounting holes in mount.
  - b. Install vibrator onto mount with four new lock nuts, compression washers, and Grade 5 bolts. (See Table II for specific size and torque requirements.) Use lock nuts and lock washers same size as bolts.

Table II. Bolt Sizes and Torque Specifications

Model Number	Bolt Size	Torque
AP5-125	1/2-13 NC	75 ft-lb (10 kgm)
AP5-200	5/8 -11 NC	170 ft-lb (23 kgm)
AP5-300	7/8-9 NC	400 ft-lb (55 kgm)
AP5-400	1-8 NC	640 ft-lb (88 kgm)

3. To install TBM wedge onto hopper, do the following:
  - a. Remove hex nut, flat washer, and slide bracket from threaded rod.
  - b. Slide TBM wedge (with vibrator attached) into mount on hopper.
  - c. Install slide bracket, flat washer, and hex nut onto TBM wedge to secure it in mount.

**▲ WARNING**

**If vibrator is mounted more than 6 in. (152 mm) above ground, install cable securing vibrator to structure. Without cable, vibrator could fall and cause injury.**

4. Secure vibrator to structure by installing a 1/4-in. (6 mm) diameter cable assembly, P/N 32271, or equivalent as follows (cable is included with Mounting Kit for Martin® AP5 Series Piston Vibrators):
  - a. Weld D-ring (A, Figure 5) onto structure wall (B) above vibrator.
  - b. Loop 1/4-in. (6 mm) wire cable (C) through hole in vibrator top plate (D) and D-ring on structure wall.
  - c. Make sure cable is taut and has 3 in. (76 mm) of turn-back at each end.

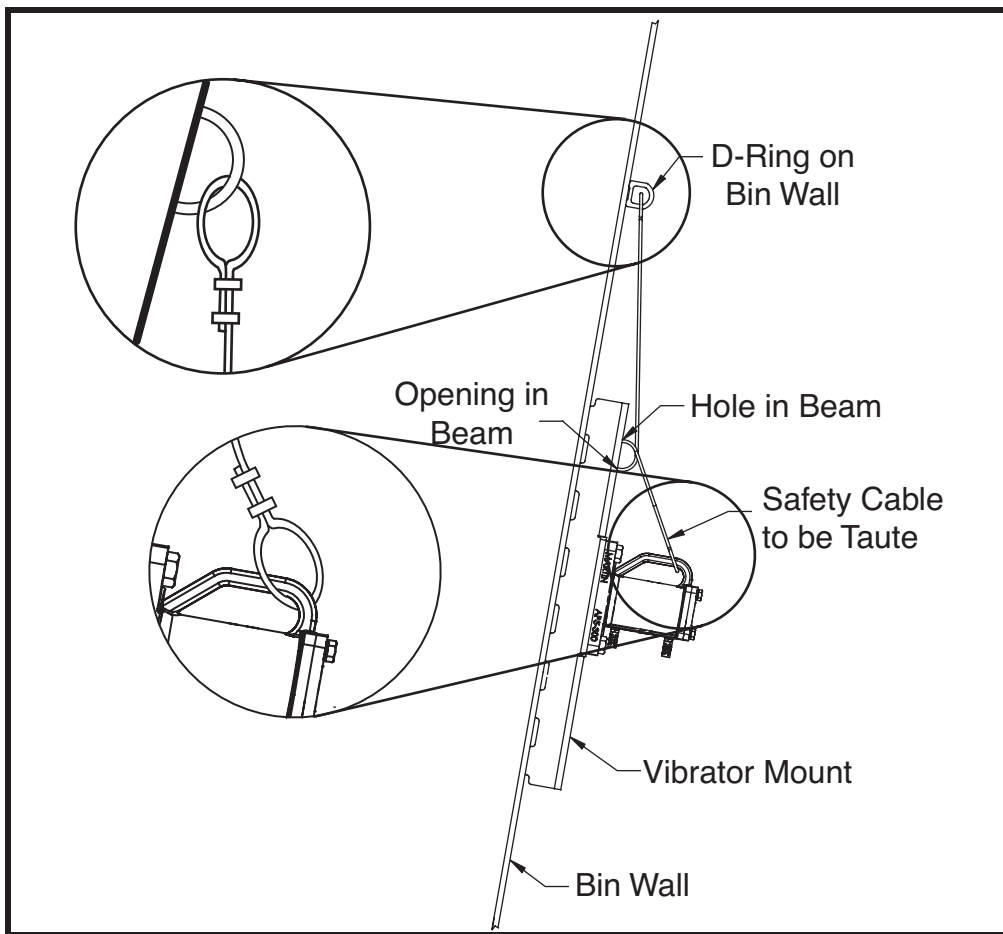

**Figure 5. Installing Vibrator Safety Cable**

- d. Apply thread sealing compound to threads of nuts on U-bolts (E). Install four cable clamps (two on each end) to secure cable to vibrator eye and D-ring. Torque nuts to 4.5 ft-lb (0.6 kgm).
- e. Trim loose ends of wire cable.

*Connecting air lines*

**IMPORTANT**

Vibration frequency and force is in direct proportion to the air pressure. At least 40 psi (2.75 bar) is required to operate the vibrator. Martin Engineering recommends using an air filter on the air line (available from Martin Engineering).

Vibrators require minimum lubrication. Excessive amounts reduce their efficiency. Lubricated air must be used at a rate of 1-2 drops per minute at 80 psi to ensure proper operation of the vibrator.

Use Martin® Air Vibrator Oil part number 14766 or equivalent.

Always “blow out” new air line prior to connecting the vibrator.

1. Run a lubricated air line (supplied by the customer) to the intake on the side of the vibrator body.
2. Remove plastic plug.
3. Connect air line to vibrator.

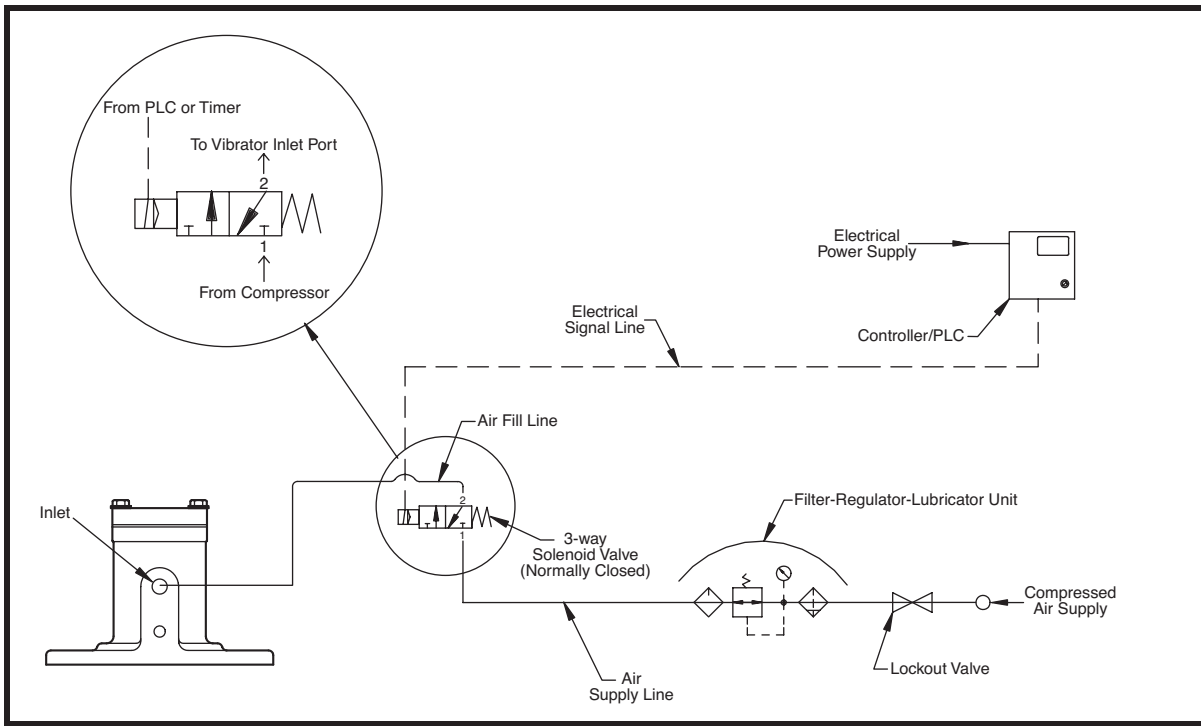

**Figure 6. Plumbing Detail for Normally-Closed Solenoid Valve**

## After Installing Vibrator

---

### IMPORTANT

Read entire section before beginning work.

1. Start vibrator.

### ⚠ WARNING

**Piston vibrators are loud when operating. Use ear protection to avoid impairment or loss of hearing.**

2. Observe operation of vibrator. If there is noticeable movement of the hopper wall or mount during operation, add more reinforcement to structure (see “Installing reinforcing beam onto structure”).
3. After 1 hour of operation, tighten mounting bolts while vibrator is operating to fully seat vibrator.

## Troubleshooting

---

If you are experiencing problems with the vibrator, see below.

Symptom	Corrective Action
Vibrator not moving material	No air pressure. Make sure air is on and reaching vibrator.
Vibrator making unusual noise	Contaminant has entered vibrator. Disassemble vibrator and clean body and piston. If piston shows signs of wear, replace piston.
Structure wall moving or beginning to tear	Wall not rigid enough. Reinforce structure wall or mount.

## Part Numbers

---

This section provides product names and corresponding part numbers for Martin® AP5 Series Piston Vibrators and related equipment. Please reference part numbers when ordering parts.

### *Martin® AP5 Series Piston Vibrators*

**Martin® AP5 Series Piston Vibrators Part Numbers**

Piston Type	Piston Size			
	1.25 in.	2 in.	3 in.	4 in.
<b>Standard</b>	AP5-125-X	AP5-200-X	AP5-300-X	AP5-400-X
<b>Quiet</b>	AP5-125Q-X	AP5-200Q-X	AP5-300Q-X	AP5-400Q-X
<b>Spring</b>	AP5-125S-X	AP5-200S-X	AP5-300S-X	AP5-400S-X
<b>Single Impacting</b>	AP5-125SI-X	AP5-200SI-X	AP5-300SI-X	AP5-400SI-X

#### *Vibrator mounts*

**Channel Mount for AP5-125:** P/N 29928-01  
**Channel Mount for AP5-200:** P/N 29928-02.  
**Channel Mount for AP5-300:** P/N 29928-03.  
**Channel Mount for AP5-400:** P/N 29928-04.

#### *Vibrator mounting kit*

**Mounting Kit for AP5-125:** P/N 29810.  
**Mounting Kit for AP5-200:** P/N 29811.  
**Mounting Kit for AP5-300:** P/N 29812.  
**Mounting Kit for AP5-400:** P/N 29813.

#### *Miscellaneous*

**Safety Cable:** P/N 32271.  
**1/2 in. (13 mm) NPT Solenoid Valve (120V 60 Hz):** P/N 36343-NC.  
**1/2 in. (13 mm) NPT Filter-Regulator-Lubricator Kit:** P/N 14760.  
**Control Line Kit:** P/N 39504.  
**Martin® Controller - single circuit:** P/N 38902-20.  
**Universal Trailer Hopper Mount Bracket Kit:** P/N 220985  
**1/2 in. (13 mm) Bronze Ball Valve:** P/N 14824.

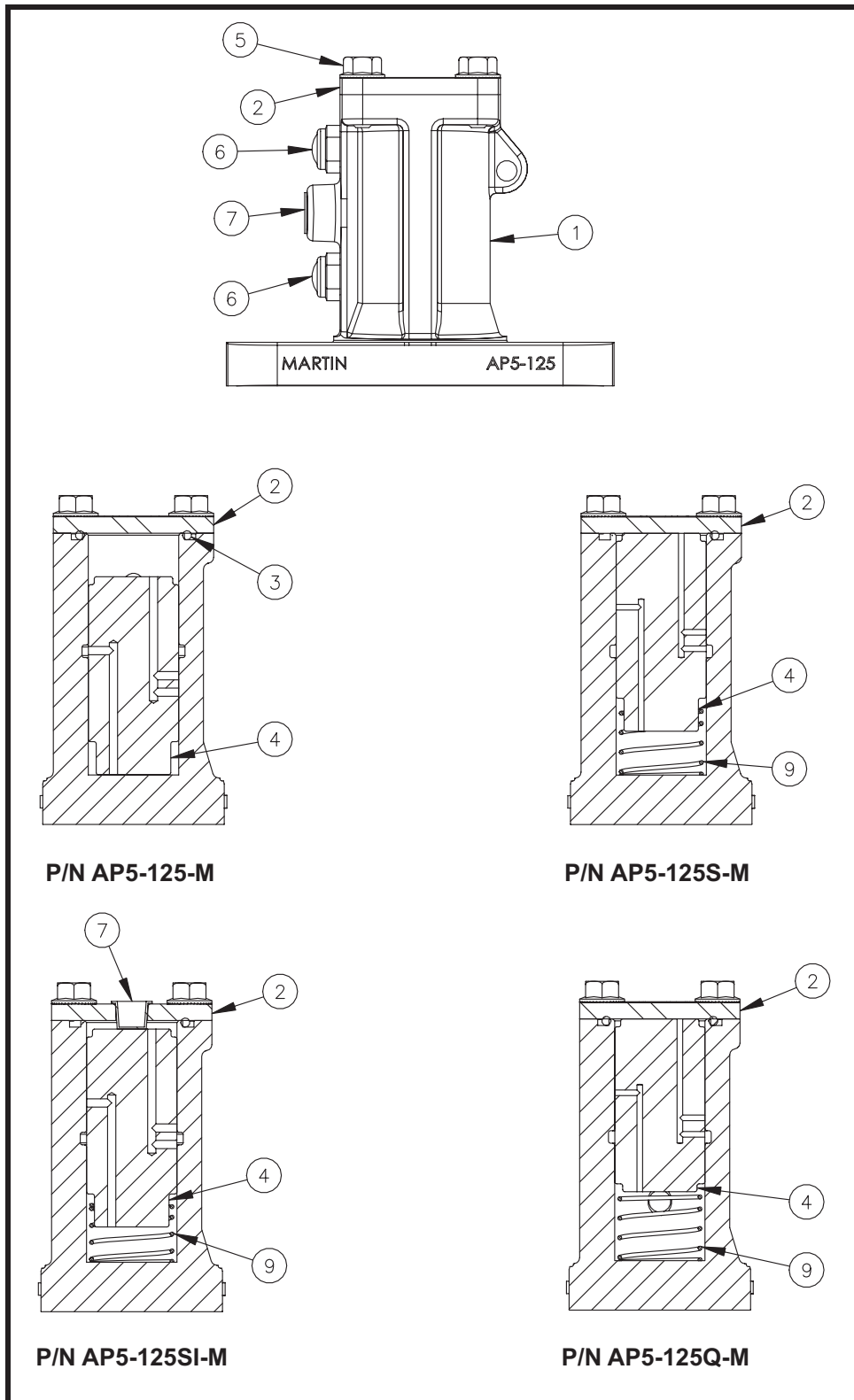

Figure 7. Martin® AP5 Series Piston Vibrator, P/N AP5-125XX-X

Item	Description	Part Number	Qty
1	Body	110535	1
2	Top Plate	Table III	1
3	O-ring	22085	1
4	Piston	Table III	1
5	Screw Hex Serrated Flange 5/16-18 x 3/4 GR5 ZP	SUS10023	4
6	Button Muffler 1/4-18 NPT	898501	Table III
7	Caplug 1/4 NPT	606012	1
(NS) 8	Plug Pipe 1/4-18NPT	17524	Table III
9	Spring Compression	29684-01	Table III
(NS) 10	Label	CG-100328-1	1
(NS) 11	Tag Loud Warning	34070	1
(NS) 12	Tie Nylon Cable	30916	1
(NS) 13	Operator's Manual	M3898	1

NS = Not Shown

**Figure 7. Martin® AP5 Series Piston Vibrator, P/N AP5-125XX-X**

**Table III. Martin® AP5 Series Piston Vibrator Part Numbers and Quantities, P/N AP5-125XX-X**

Part Number	Description	P/N Item 2	P/N Item 4	Qty Item 6	Qty Item 8	Qty Item 9
AP5-125-M	Standard	CG-100419	31004-01	2	0	0
AP5-125Q-M	Quiet	CG-100419	31004-01Q	2	0	1
AP5-125S-M	Spring	CG-100419	31004-01	2	0	1
AP5-125SI-M	Single Impacting	CG-100419-T	31004-01	1	2	1

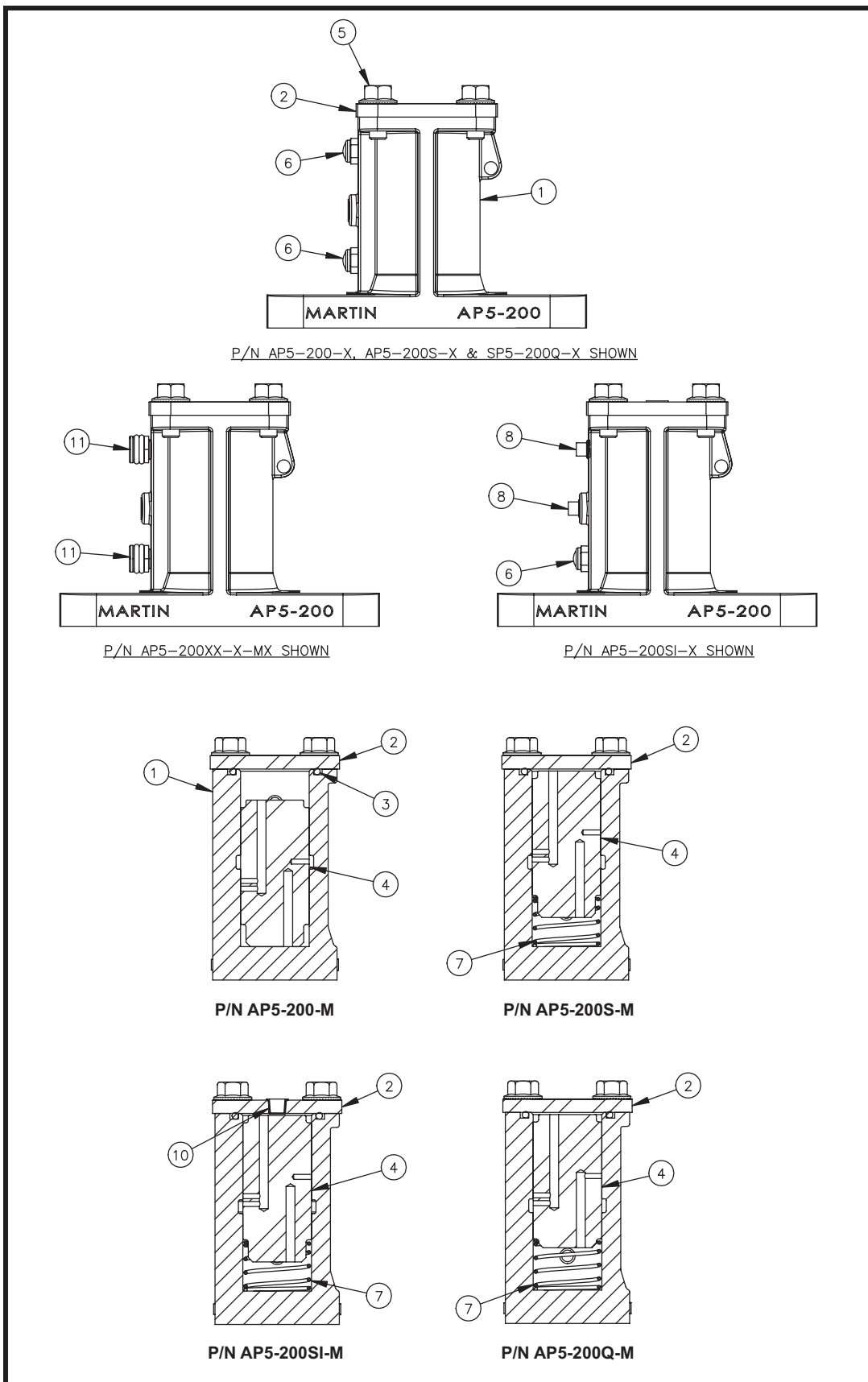

Figure 8. Martin® AP5 Series Piston Vibrator, P/N AP5-200XX-X

Item	Description	Part Number	Qty
1	Body	110531	1
2	Top Plate	Table IV	1
3	O-ring	897154	1
4	Piston	Table IV	1
5	Screw Hex Serrated Flange 1/2-13 x 1 ZP	CG-100457	4
6	Button Muffler 1/4-18 NPT	898501	Table IV
7	Spring Compression	897209	Table IV
8	Plug Pipe 1/4-18NPT	17524	Table IV
(NS) 9	Label	CG-100328-2	1
10	Caplug 1/4 NPT	606012	1
11	O-ring Muffler	Table IV	Table IV
(NS) 12	Operator's Manual	M3898	1
(NS) 13	Tag Loud Warning	34070	1
(NS) 14	Tie Wire Cable	30916	1

NS = Not Shown

**Figure 8. Martin® AP5 Series Piston Vibrator, P/N AP5-200XX-X**

**Table IV. Martin® AP5 Series Piston Vibrator Part Numbers and Quantities, P/N AP5-200XX-X**

Part Number	Description	P/N Item 2	P/N Item 4	Qty Item 6	Qty Item 7	Qty Item 8	Qty Item 11
AP5-200-X	Standard	CG-100398	CG-100456	2	0	0	0
AP5-200-X-MX	Standard	CG-100398	CG-100456	0	0	0	2
AP5-200Q-X	Quiet	CG-100398	CG-100456-Q	2	1	0	0
AP5-200Q-X-MX	Quiet	CG-100398	CG-100456-Q	0	1	0	2
AP5-200S-X	Spring	CG-100398	CG-100456	2	1	0	0
AP5-200S-X-MX	Spring	CG-100398	CG-100456	0	1	0	2
AP5-200SI-X	Single Impacting	CG-100398-T	CG-100456	1	1	2	0
AP5-200SI-X-MX	Single Impacting	CG-100398-T	CG-100456	0	1	2	1

Part Number	Description	P/N Item 11
AP5-200XX-X-MA	Aluminum	CG-100426-A
AP5-200XX-X-MB	Brass	CG-100426-B
AP5-200XX-XMC	304 SS	CG-100426-C

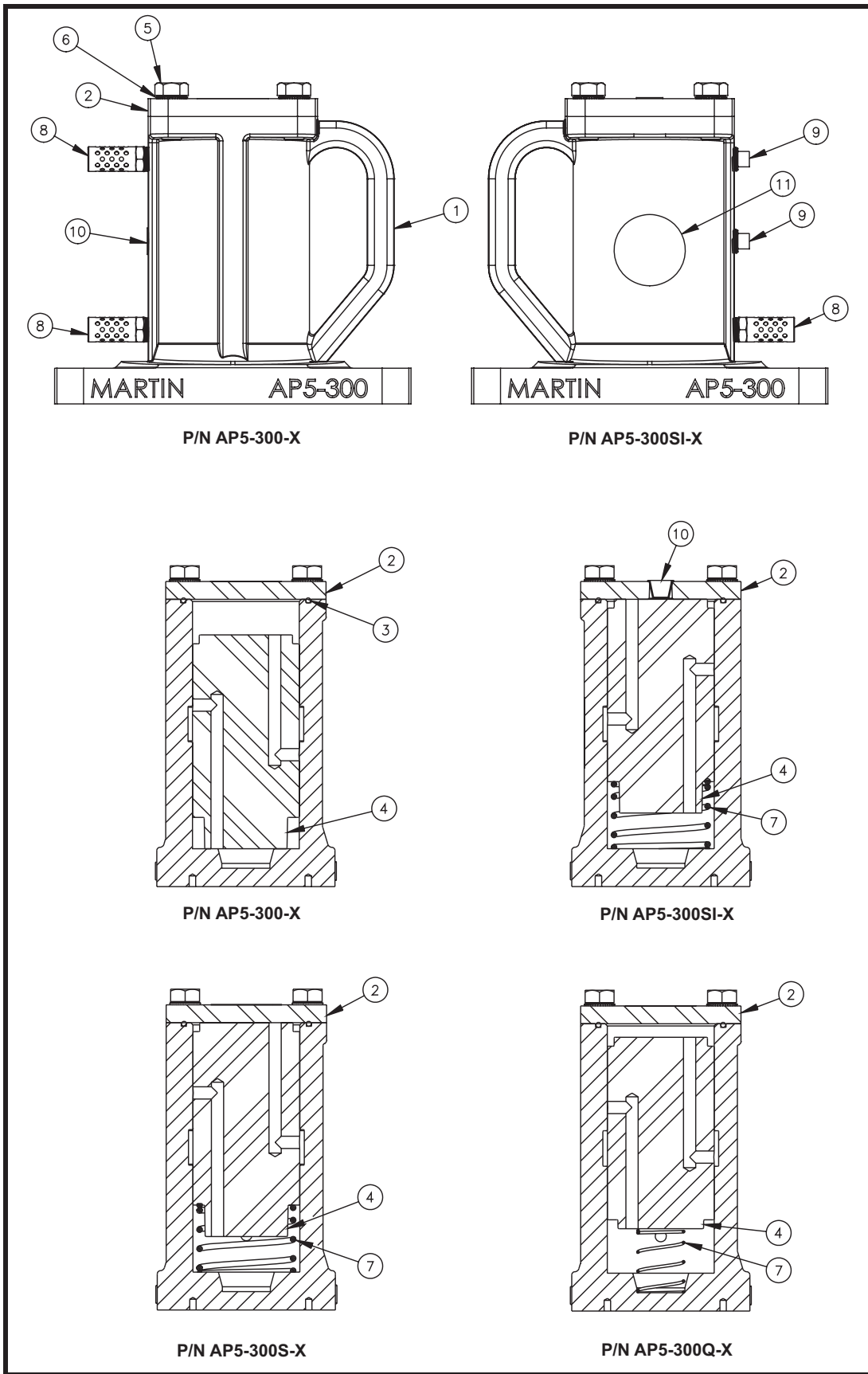

Figure 9. Martin® AP5 Series Piston Vibrator, P/N AP5-300XX-X

Item	Description	Part Number	Qty
1	Body	CG-100432	1
2	Top Plate	Table V	1
3	O-ring #237 N70	603012	1
4	Piston	Table V	1
5	Screw HHC 9/16-12 x 1-1/4 Gr8 ZP	CG-100435	4
6	Washer Compression D14 Serrated Schnorr	CG-100434	4
7	Spring 2.47 ID x .156 WD x 2.5 LG	Table V	Table V
8	Muffler Metal 3/8 NPT	210316	Table V
9	Plug Pipe Sq Head 3/8 NPT	17788	Table V
10	Cap Plug 3/8	606013	1
11	Label	CG-100328-2	1
(NS) 12	Operator's Manual	M3898	1
(NS) 13	Tag Loud Warning	34070	1
(NS) 14	Tie Nylon Cable	30916	1

NS = Not Shown

**Figure 9. Martin® AP5 Series Piston Vibrator, P/N AP5-300XX-X**

**Table V. Martin® AP5 Series Piston Vibrator Part Numbers and Quantities, P/N AP5-300XX-X**

Part Number	Description	P/N Item 2	P/N Item 4	P/N Item 7	Qty Item 8	Qty Item 8	Qty Item 9
AP5-300-X	Standard	CG-100433	31004-03	—	0	2	0
AP5-300Q-X	Quiet	CG-100433	31004-03Q	29684-05	1	2	0
AP5-300S-X	Spring	CG-100433	31004-03	29684-03	1	2	0
AP5-300SI-X	Single Impacting	CG-100433-T	31004-03	29684-03	1	1	2

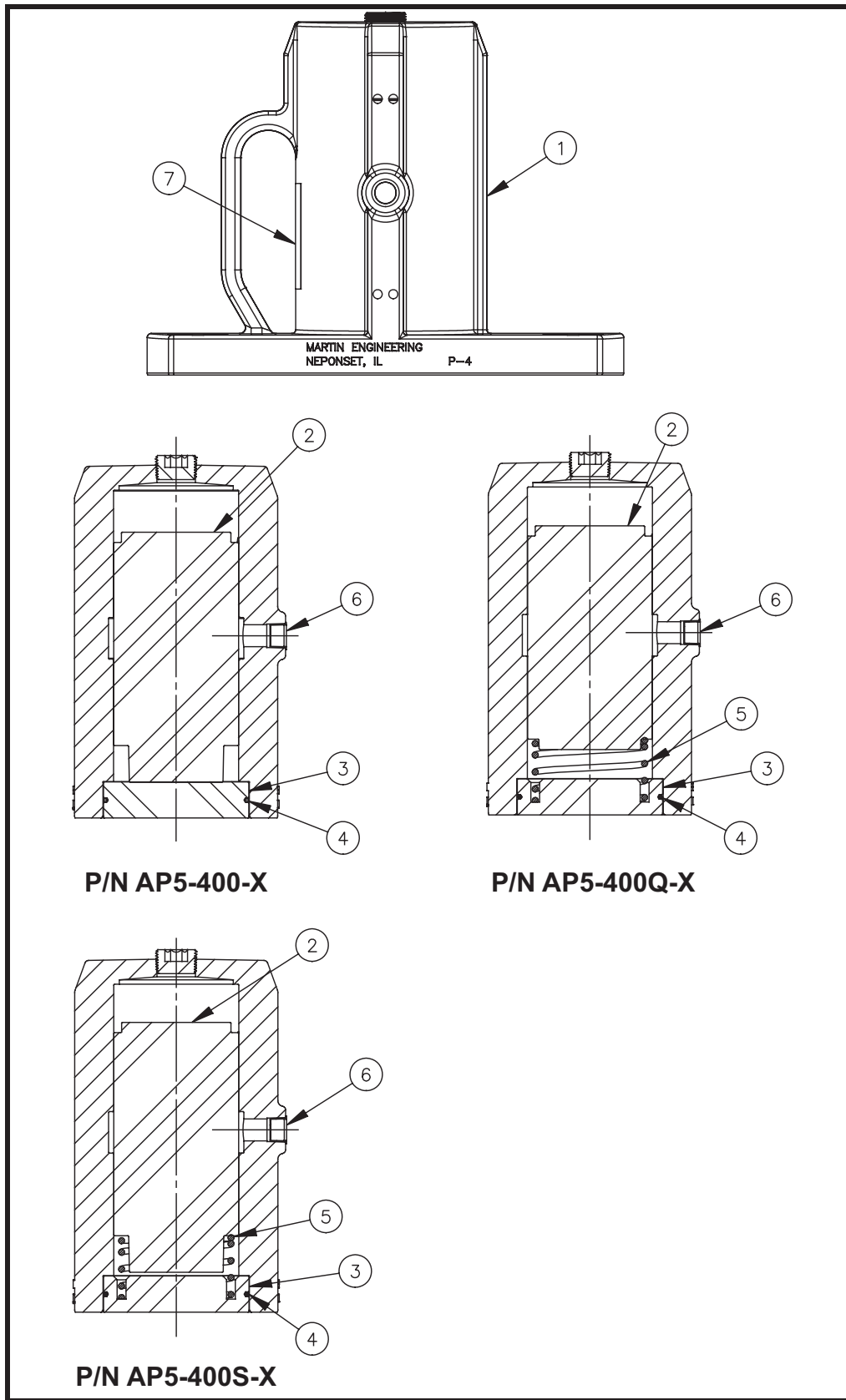

Figure 10. Martin® AP5 Series Piston Vibrator, P/N AP5-400-X

Item	Description	Part Number	Qty
1	Body	29490	1
2	Piston	Table VI	1
3	Strike Plate	Table VI	1
4	O-ring #245 4.359 ID x .139 CS N 70A	11859	1
5	Spring 3.31 ID x .192 WD x 4.34 LG	29684-04	Table VI
6	Caplug 1/2 NPT	606014	1
7	Label Vibrator Warning	29814	1
(NS) 8	Operator's Manual	M3898	1
(NS) 9	Label Martin Product	32238	1
(NS) 10	Tie Nylon Cable	30916	1
(NS) 11	Tag Loud Noise Warning	34070	1

NS = Not Shown

**Figure 10. Martin® AP5 Series Piston Vibrator, P/N AP5-400-X**

**Table IV. Martin® AP5 Series Piston Vibrator Part Numbers and Quantities, P/N AP5-200XX-X**

Part Number	Description	P/N Item 2	P/N Item 3	P/N Item 5
AP5-400-X	Standard	31004-04	29493	0
AP5-400Q-X	Quiet	31004-04Q	29493-Q	1
AP5-400S-X	Spring	31004-04	29493-Q	1

# Appendix A

## Martin® AP5 Series Piston Vibrator Specifications

Model	Piston Size in.	40 psi				60 psi				80 psi			
		VPM	CFM (L/sec)	Force lb (kg)	VPM	CFM (L/sec)	Force lb (kg)	VPM	CFM (L/sec)	Force lb (kg)	VPM	CFM (L/sec)	Force lb (kg)
AP5-125	1.25	3200	10 (4.72)	104 (47)	4500	12.5 (5.90)	206 (93)	5000	15 (7.08)	255 (116)			
AP5-125Q	1.25	2700	10 (4.72)	68 (31)	3000	12.5 (5.90)	84 (38)	3500	15 (7.08)	114 (52)			
AP5-200	2	2640	9 (4.25)	175 (79)	3180	14 (6.61)	254 (115)	3600	18 (8.50)	325 (147)			
AP5-200Q	2	2200	12 (5.66)	110 (50)	2600	17.5 (8.26)	155 (70)	2800	20 (9.44)	180 (82)			
AP5-300	3	2400	22 (10.38)	899 (408)	2800	25 (11.80)	1224 (555)	3200	35 (16.52)	1699 (771)			
AP5-300Q	3	1400	25 (11.80)	284 (129)	1800	32 (15.10)	469 (213)	2000	40 (18.88)	506 (230)			
AP5-400	4	1500	22 (10.38)	1330 (603)	1750	25 (11.80)	2010 (912)	1900	42 (19.82)	2200 (998)			
AP5-400Q	4	1000	20 (9.44)	590 (268)	1100	22 (10.38)	820 (372)	1150	42 (19.82)	1000 (454)			

## Appendix B

### Martin® AP5 Series Piston Vibrator Dimensions

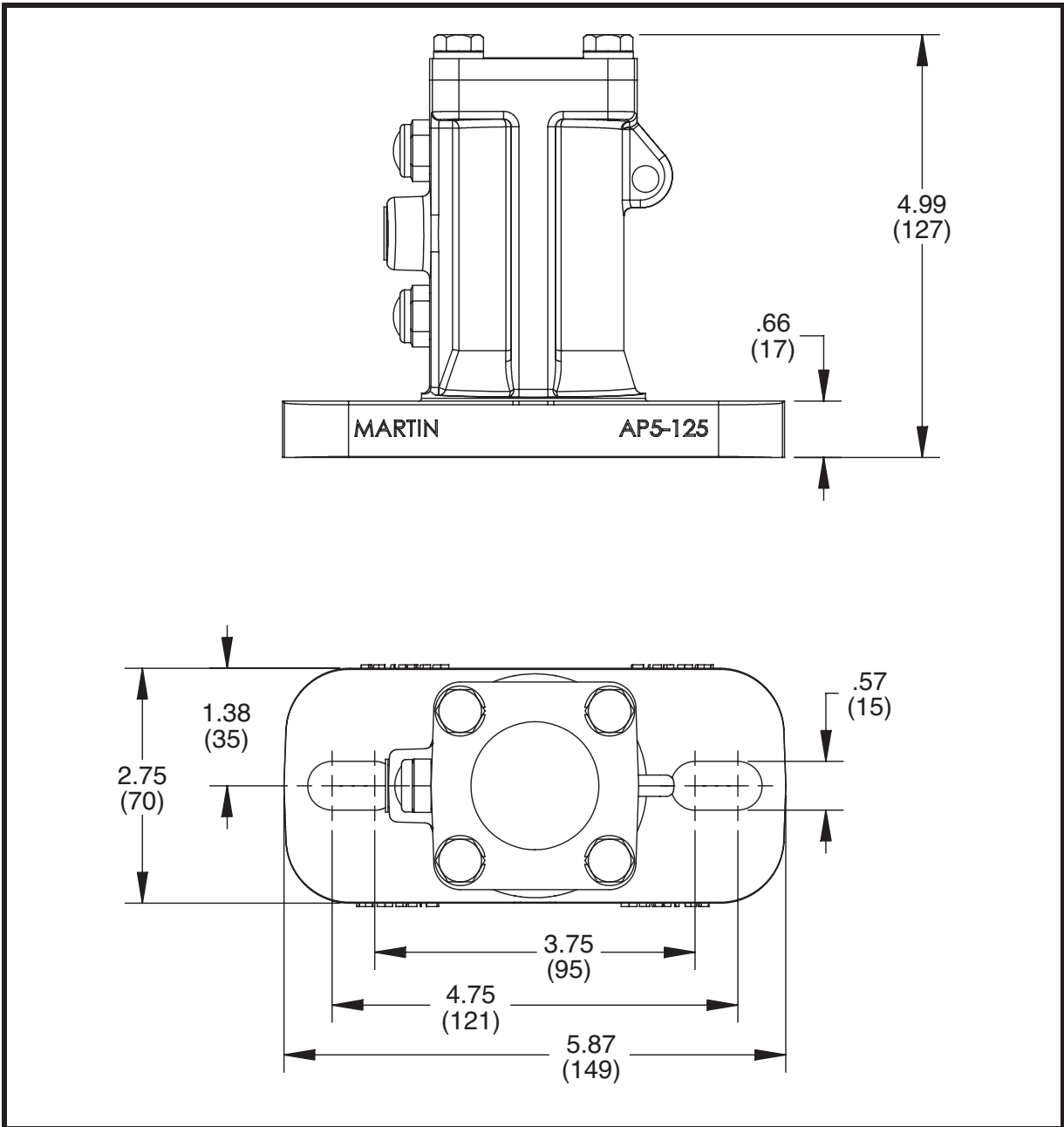

**Martin® AP5-125XX-X Piston Vibrator Dimensions**

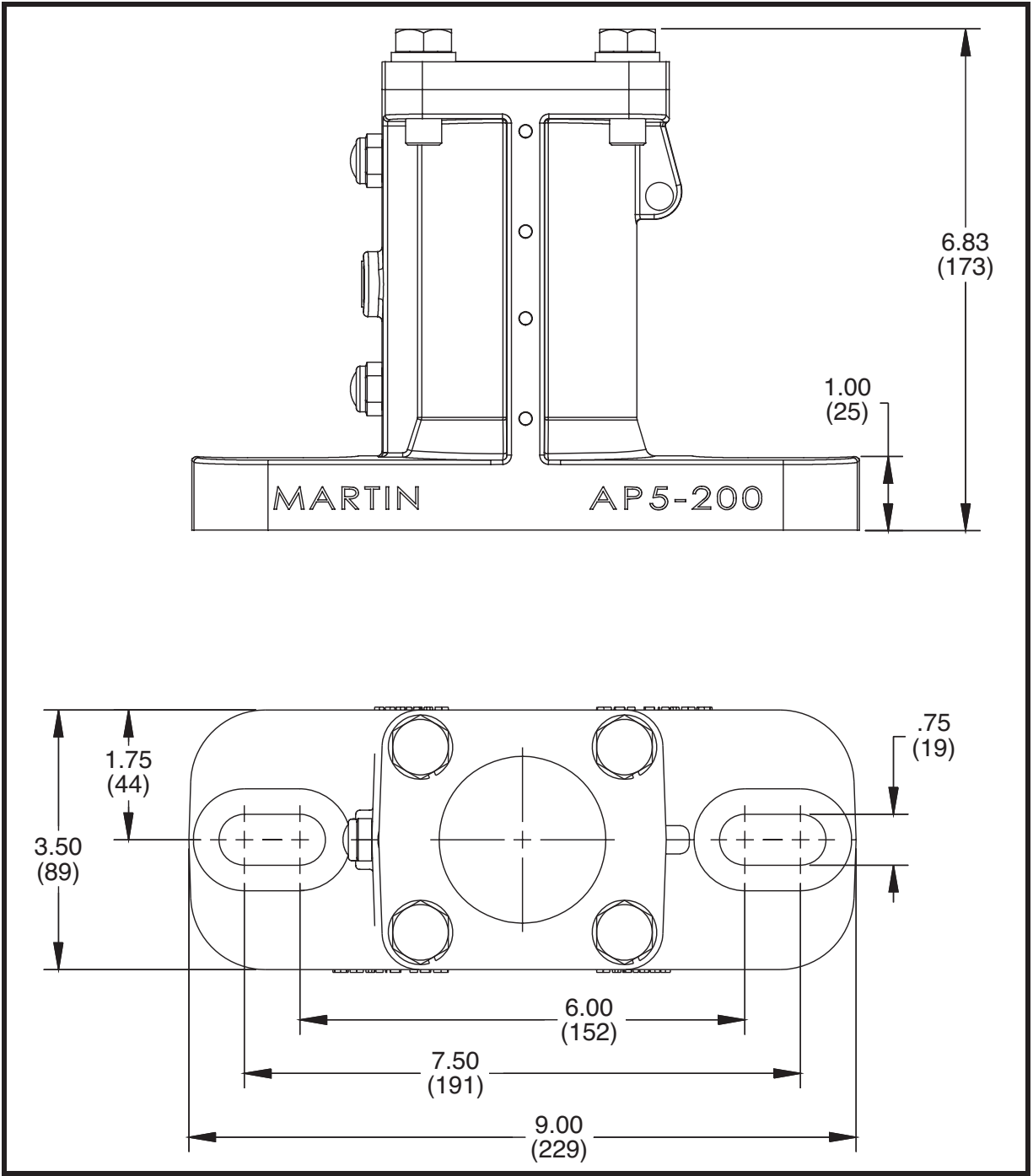

**Martin® AP5-200XX-X Piston Vibrator Dimensions**

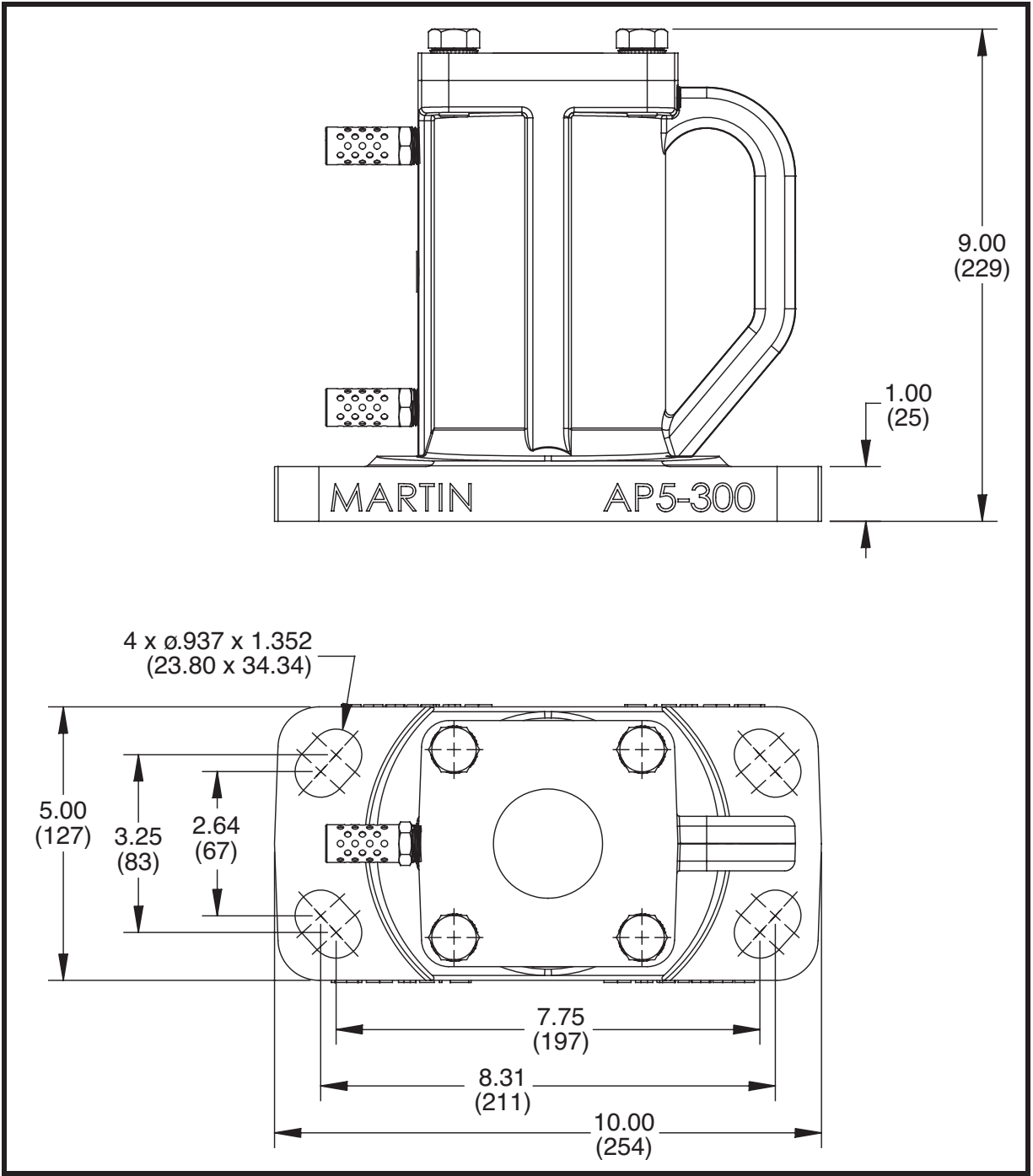

**Martin® AP5-300XX-X Piston Vibrator Dimensions**

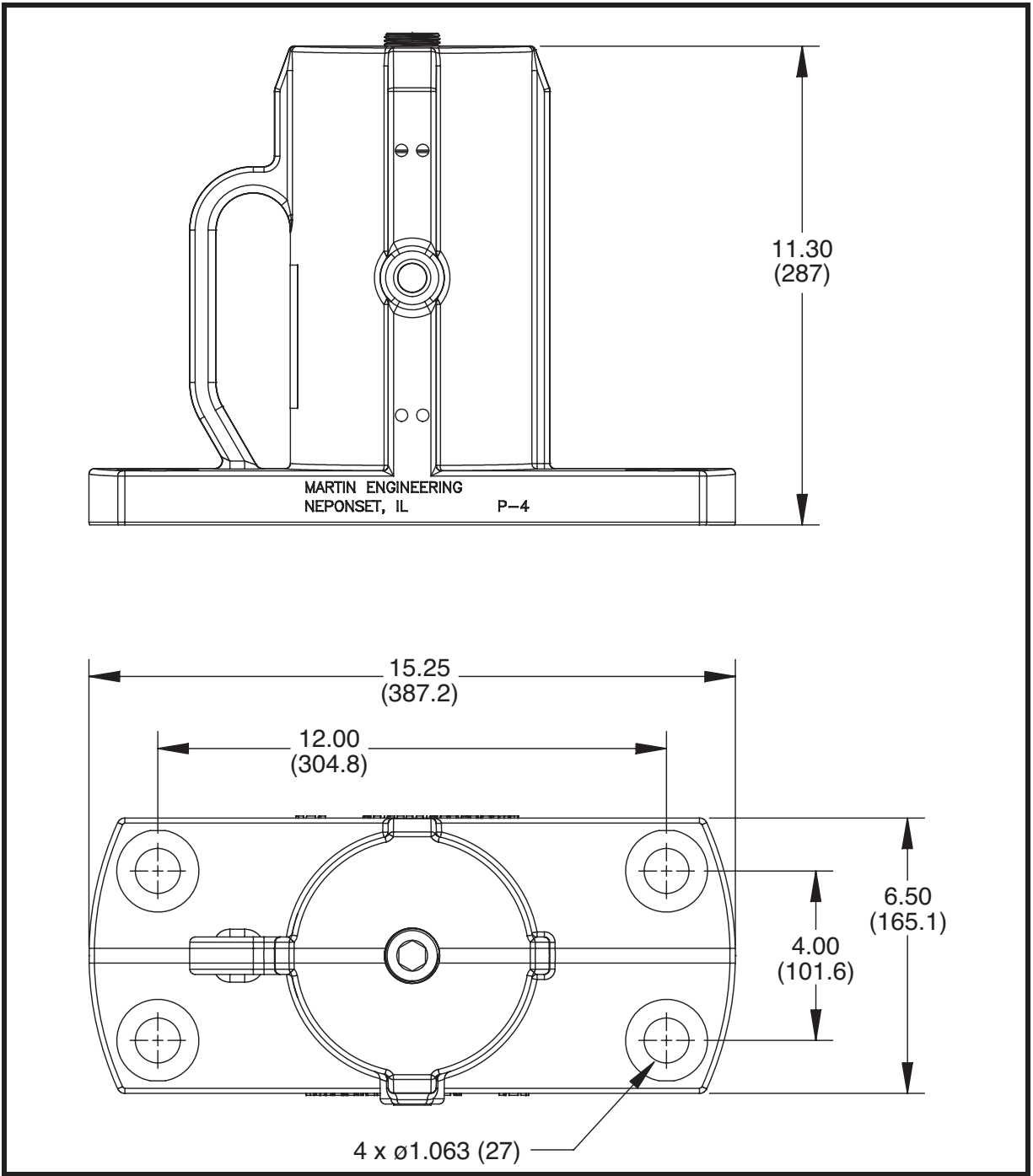

**Martin® AP5-400-X Piston Vibrator Dimensions**

*Any product, process, or technology described here may be the subject of intellectual property rights reserved by Martin Engineering Company. Trademarks or service marks designated with the ® symbol are registered with the U.S. Patent and Trademark Office and may be proprietary in one or more countries or regions. Other trademarks and service marks belonging to Martin Engineering Company in the United States and/or other countries or regions may be designated with the “TM” and “SM” symbols. Brands, trademarks, and names of other parties, who may or may not be affiliated with, connected to, or endorsed by Martin Engineering Company, are identified wherever possible.*

*Additional information regarding Martin Engineering Company’s intellectual property can be obtained at [www.martin-eng.com/trademarks](http://www.martin-eng.com/trademarks).*

# **Problem Solved™** ***GUARANTEED!***

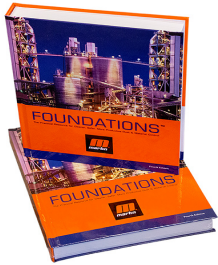

*For nearly 30 years, Martin Engineering's Foundations™ Books have taught industry personnel to operate and maintain clean and safe belt conveyors. The Foundations™ Book, fourth edition, focuses on improving belt conveyors by controlling fugitive material. "The Practical Resource for Total Dust and Material Control," is a 576-page hard cover volume that provides information of value to industries where the efficient handling of bulk materials is a key to productivity and profitability.*

*Expanding upon the book, our Foundations™ Training Program addresses the design and development of more productive belt conveyors, and is offered in three customizable seminars. Attendees gain a better understanding of conveyor safety and performance, helping to justify upgrade investments and increase profitability.*



## **Martin Engineering USA**

One Martin Place  
Neponset, IL 61345-9766 USA  
800 544 2947 or 309 852 2384  
Fax 800 814 1553  
[www.martin-eng.com](http://www.martin-eng.com)

**COMPANY WITH  
QUALITY SYSTEM  
CERTIFIED BY DNV  
ISO 9001**