



# ***Martin® Vibrating Dribble Chute***

[Go to Martin® Vibrating Dribble Chute web page](#)



***Operator's Manual  
M3232***

# Important

MARTIN ENGINEERING HEREBY DISCLAIMS ANY LIABILITY FOR: DAMAGE DUE TO CONTAMINATION OF THE MATERIAL; USER'S FAILURE TO INSPECT, MAINTAIN AND TAKE REASONABLE CARE OF THE EQUIPMENT; INJURIES OR DAMAGE RESULTING FROM USE OR APPLICATION OF THIS PRODUCT CONTRARY TO INSTRUCTIONS AND SPECIFICATIONS CONTAINED HEREIN. MARTIN ENGINEERING'S LIABILITY SHALL BE LIMITED TO REPAIR OR REPLACEMENT OF EQUIPMENT SHOWN TO BE DEFECTIVE.

Observe all safety rules given herein along with owner and Government standards and regulations. Know and understand lockout/tagout procedures as defined by American National Standards Institute (ANSI) z244.1-1982, *American National Standard for Personnel Protection - Lockout/Tagout of Energy Sources - Minimum Safety Requirements* and Occupational Safety and Health Administration (OSHA) Federal Register, Part IV, 29 CFR Part 1910, *Control of Hazardous Energy Source (Lockout/Tagout); Final Rule*.

The following symbols may be used in this manual:



**Danger:** Immediate hazards that will result in severe personal injury or death.



**Warning:** Hazards or unsafe practices that could result in personal injury.



**Caution:** Hazards or unsafe practices that could result in product or property damages.



**Important:** Instructions that must be followed to ensure proper installation/operation of equipment.



**Note:** General statements to assist the reader.

# Table of Contents

---

<b>Section</b>	<b>Page</b>
List of Figures .....	ii
Introduction .....	1
General .....	1
References .....	1
Safety .....	1
Materials required .....	1
Before Installing Vibrating Dribble Chute.....	2
Installing Vibrating Dribble Chute.....	4
Installing mounting bracket .....	4
Installing dribble sheet and vibrator.....	5
Installing restraining cable .....	6
After Installing Vibrating Dribble Chute.....	7
Weekly Maintenance .....	8
Troubleshooting .....	10
Part Numbers .....	11

## **List of Figures**

---

<b>Figure</b>	<b>Title</b>	<b>Page</b>
1	Minimum Clearance for Vibrating Dribble Chute Installation . . . . .	3
2	Dimensions for Slot and Welded Stock . . . . .	4
3	Installing Restaining Cable . . . . .	6
4	Martin® Vibrating Dribble Chute Assembly, P/N 31546 . . . . .	12
5	Dribble Sheet, P/N 31494-XXXXXXX . . . . .	13

# Introduction

---

## ***General***

The Martin<sup>®</sup> Vibrating Dribble Chute provides an effective, economical, low-maintenance method to return material removed by secondary belt cleaners and buildup on chute walls back to the main material flow. The action of the vibrator keeps material moving, rather than allowing it to adhere to the dribble chute.

The key to the Martin<sup>®</sup> Vibrating Dribble Chute's success is the unique vibrator mounting bracket designed to reduce material accumulation without damaging the chute. This mount isolates the vibrator from the wall, reducing metal fatigue and structural damage.

## ***References***

The following documents are referenced in this manual:

- American National Standards Institute (ANSI) z244.1-1982, *American National Standard for Personnel Protection - Lockout/Tagout of Energy Sources - Minimum Safety Requirements*, American National Standards Institute, Inc., 1430 Broadway, New York, NY 10018.
- Federal Register, Volume 54, Number 169, Part IV, 29 CFR Part 1910, *Control of Hazardous Energy Source (Lockout/Tagout); Final Rule*, Department of Labor, Occupational Safety and Health Administration (OSHA), 32nd Floor, Room 3244, 230 South Dearborn Street, Chicago, IL 60604.
- *Martin<sup>®</sup> Zero-Frame Electric Vibrators Operator's Manual*, P/N M3892.

## ***Safety***

All safety rules defined in the above documents and all owner/employer safety rules must be strictly followed when working on the vibrating dribble chute.

## ***Materials required***

Standard hand tools are required to install and service this equipment.

## Before Installing Vibrating Dribble Chute

---

1. Inspect shipping boxes for damage. Report damage to delivery service. Fill out damage report and return to Martin Engineering.
2. Remove vibrating dribble chute parts from shipping boxes. Equipment in boxes should include the following:
  - Martin<sup>®</sup> Vibrating Dribble Chute Assembly.
  - Martin<sup>®</sup> Electric Vibrator.
  - *Martin<sup>®</sup> Zero-Frame Electric Vibrators Operator's Manual*, P/N M3892.
  - Warranty card.
  - Damage report.
3. If anything is missing or damaged, contact Martin Engineering or a representative. Fill out warranty card and return to Martin Engineering.



### **⚠ WARNING**

**Before installing equipment, turn off and lock out/tag out energy source to conveyor and conveyor accessories.**

4. Turn off and lock out/tag out energy source according to ANSI standards (see “References”).

### **⚠ WARNING**

**If equipment will be installed in an enclosed area, gas level or dust content must be tested before using a cutting torch or welding. Using a cutting torch or welding in an area with gas or dust may cause an explosion.**

5. If using a cutting torch or welding, test atmosphere for gas level or dust content. Cover conveyor belt with fire-retardant cover.
6. Make sure mounting surface and vibrator are clean and free of debris.

### **IMPORTANT**

**Before installing dribble sheet, determine minimum clearance from dribble sheet to conveyor belt. Clearance of 1/2 in. (13 mm) is recommended so that belt will not catch vibrating dribble chute and damage it.**

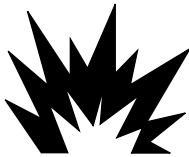

- 7. See Figure 1. Determine clearance for dribble sheet by checking movement of conveyor belt and splices while belt is loaded and unloaded. (Clearance of 1/2 in. [13 mm] is recommended.)

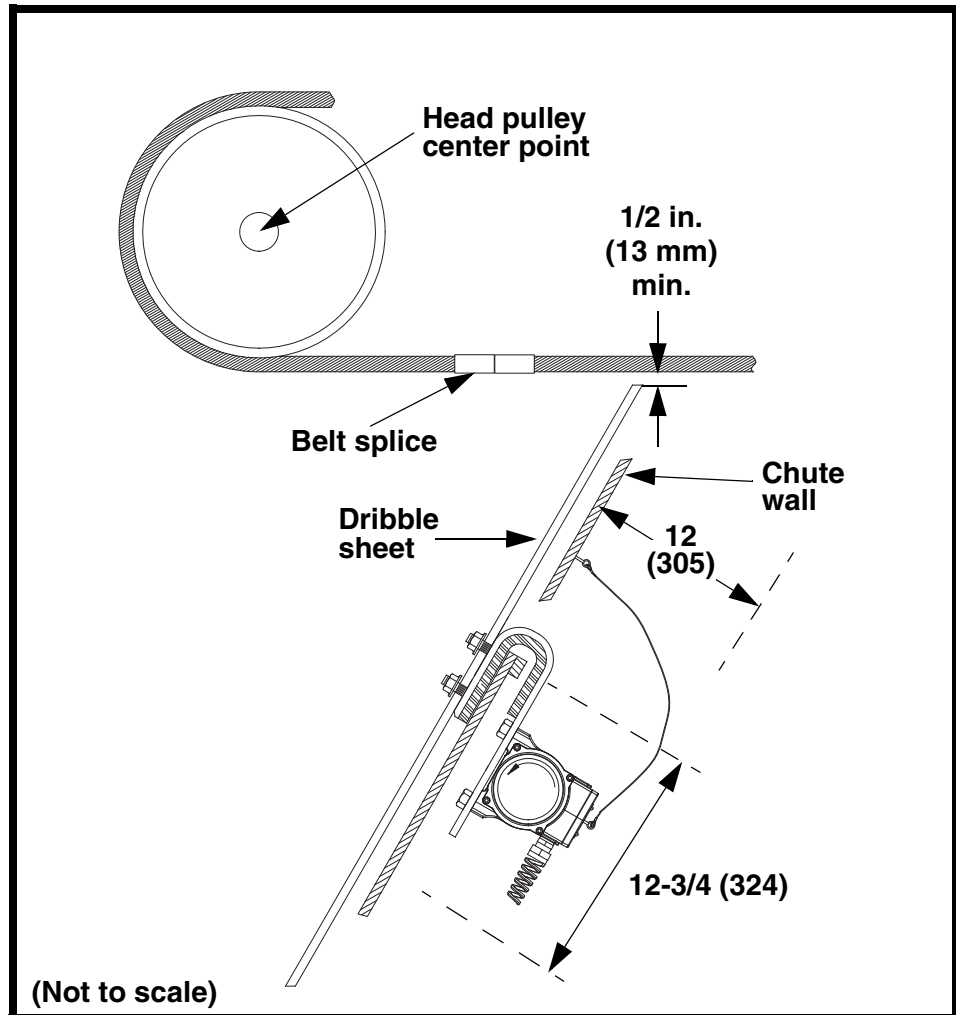

Figure 1. Minimum Clearance for Vibrating Dribble Chute Installation

- 8. Make sure location for slot allows clearance shown in Figure 1. (Clearance area is required to assemble unit and tighten vibrator mounting hardware.)

# Installing Vibrating Dribble Chute

## IMPORTANT

Read entire section before beginning work.

To install the vibrating dribble chute, follow the procedures corresponding to the following steps:

1. Install vibrating dribble chute mounting bracket onto chute wall.
2. Install dribble sheet and vibrator onto mounting bracket.

## NOTE

### Installing mounting bracket

Vibrator mounting bracket hangs on chute wall through “slot” cut into chute wall. Location of slot is determined by length and width of chute and location of structural supports.

1. See Figure 2. Determine where to cut mounting slot (A) in chute wall (B). Center slot under belt parallel to belt width.
2. Cut slot in chute wall and remove burrs and sharp edges.

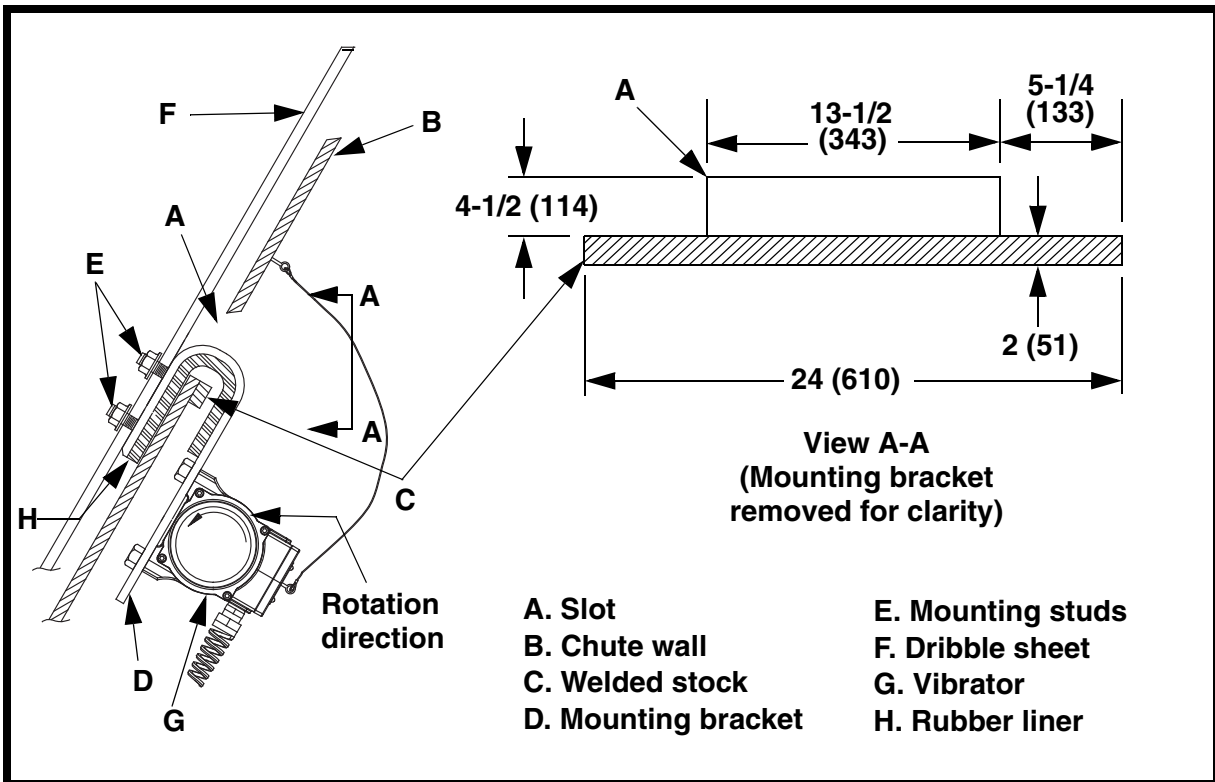

Figure 2. Dimensions for Slot and Welded Stock



**⚠ CAUTION**

If chute wall is less than 1/4 in. (6 mm) thick, a piece of flat steel stock must be welded to the chute, parallel to and flush against the bottom edge of the slot. Chute wall could tear if not reinforced.

3. If chute wall is less than 1/4 in. (6 mm) thick, weld a piece of flat stock (C) 3/8 x 2 x 24 in. (9 x 51 x 610 mm) to the chute wall as shown in Figure 2.
4. Insert mounting bracket (D) through slot and hang on chute wall so mounting studs (E) are inside the chute.

**⚠ CAUTION**

Do not overtighten hex nuts when installing dribble sheet. Overtightening may cause polyethylene sheet to crack.

1. Install dribble sheet (F, Figure 2) onto mounting studs and secure with hex nuts and washers. Hand-tighten hex nuts to snug so dribble sheet does not crack from over-tightening.
2. Install vibrator (G) to mounting bracket according to *Martin*<sup>®</sup> *Zero-Frame Electric Vibrators Operator's Manual*, P/N M3892.

**IMPORTANT**

Make sure vibrator is set to produce less than 250 lbs of force. Exceeding 250 lbs of force may cause damage to dribble chute.

3. Verify vibrator is set to produce less than 250 lbs of force. Adjust eccentric weights according to vibrator operator's manual.

***Installing dribble sheet and vibrator***

*Installing  
restraining cable*

**▲ WARNING**

If vibrator is mounted more than 6 in. (152 mm) above ground, install cable securing vibrator to structure. Without cable, vibrator could fall and cause injury.

1. Secure vibrator to structure by installing restraining cable as follows:
  - a. Weld D-ring (A, Figure 3) onto structure wall (B) above vibrator.

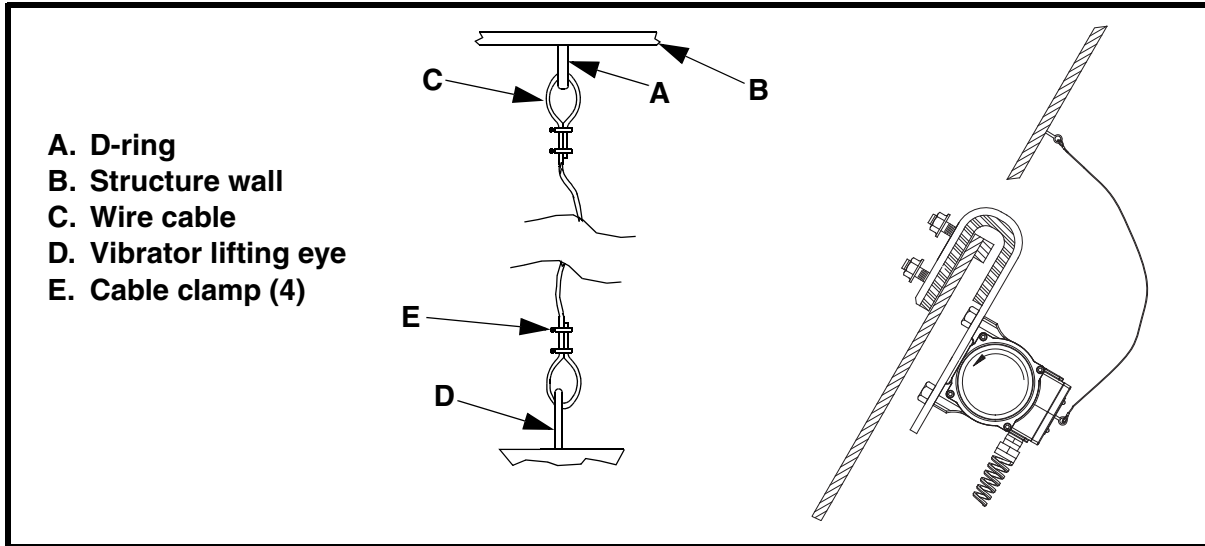

**Figure 3. Installing Restraining Cable**

- b. Loop 1/4-in. (6 mm) wire cable (C) through vibrator lifting eye (D) and D-ring on structure wall.
- c. Leave no more than 2 in. of slack in cable.
- d. Apply thread-sealing compound to nuts on cable clamps (E). Install four cable clamps (two on each end) to secure cable to vibrator eye and D-ring. Torque nuts on cable clamps to 15–30 ft-lbs.
- e. Trim loose ends of wire cable.

# After Installing Vibrating Dribble Chute

## IMPORTANT

Read entire section before beginning work.

1. Make sure dribble sheet has 1/2 in. (13 mm) minimum clearance under conveyor belt.
2. Ensure eccentric weights on vibrator rotate in direction shown in Figure 2.

## WARNING

Failure to remove tools from installation area and conveyor belt before turning on energy source can cause serious injury to personnel and damage to belt.

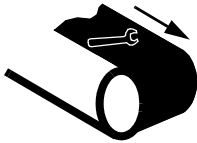

3. Remove all tools and fire retardant cover from installation area and conveyor belt.

## DANGER

Do not touch or go near conveyor belt or conveyor accessories when conveyor belt is running. Body or clothing can get caught and pull body into conveyor belt, causing severe injury or death.



4. Turn on conveyor belt and vibrating dribble chute for 1 hour.
5. Observe vibrating dribble chute to make sure fugitive material is being returned to the main material stream.

## WARNING

Before adjusting vibrating dribble chute, turn off and lock out/tag out energy source to conveyor belt and conveyor accessories.



6. After 1 hour of operation, turn off and lock out/tag out energy source according to ANSI standards (see “References”).
7. Make sure all fasteners are tight. Tighten if necessary.
8. If vibrating dribble chute is not moving material properly, see “Troubleshooting.”

## Weekly Maintenance

---



### IMPORTANT

Read entire section before beginning work.

### WARNING

**Before adjusting vibrating dribble chute, turn off and lock out/tag out energy source to conveyor belt and conveyor accessories.**

1. Turn off and lock out/tag out energy source according to ANSI standards (see “References”).
2. Make sure all fasteners are tight. Tighten if necessary.
3. Check dribble sheet (F, Figure 2) to ensure minimum clearance is maintained. If belt has sagged, adjust vibrating dribble chute to prevent damage.
4. Make sure rubber liner (H) on mounting bracket (D) is not worn. If it is, replace as follows:
  - a. Remove vibrator (G, Figure 2) and dribble sheet from mounting bracket.
  - b. Remove mounting bracket from slot (A) in chute wall (B).
  - c. Scrape off worn rubber liner using a chisel or putty knife.

### NOTE

**Use 3M™ Scotch-Grip™ High-Performance Contact Adhesive or equivalent to glue new rubber liner to mounting bracket.**

- d. Brush adhesive on both the new rubber liner and mounting bracket. Press rubber liner into place starting at chamfer end of mounting bracket. Clamp for at least 1 hour or until set.

### CAUTION

**Use only new Grade 5 bolts and lock nuts to install vibrator. Old fasteners can break and cause damage to vibrator or vibrating dribble chute.**

- e. Re-install mounting bracket, dribble sheet, and vibrator.

### IMPORTANT

**The Martin® Electric Vibrator requires additional maintenance. See *Martin® Zero-Frame Electric Vibrators Operator’s Manual*, P/N M3892, for instructions.**

5. Maintain vibrator according to *Martin® Zero-Frame Electric Vibrators Operator’s Manual*, P/N M3892.

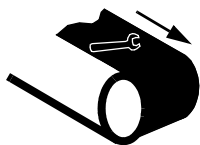

**⚠ WARNING**

Failure to remove tools from installation area and conveyor belt before turning on energy source can cause serious injury to personnel and damage to belt.

6. Remove all tools from maintenance area.

**⚠ DANGER**

Do not touch or go near conveyor belt or conveyor accessories when conveyor belt is running. Body or clothing can get caught and pull body into conveyor belt, causing severe injury or death.

7. Start conveyor belt.



# Troubleshooting

---

If you are experiencing problems with the vibrating dribble chute, see below:

Symptom	Corrective Action
Dribble sheet touching bottom of conveyor belt.	Give vibrating dribble chute more clearance below conveyor belt.
Chute wall beginning to tear.	Chute wall too thin. Weld a piece of flat stock to chute wall (see Figure 2).
Material building up on vibrating dribble chute.	<ul style="list-style-type: none"> <li>• Eccentric weights in vibrator turning the wrong way. (See vibrator manual for procedure on setting weights.)</li> <li>• Vibrator not working. See vibrator manual.</li> </ul>
Vibrating dribble chute assembly making excessive noise.	<ul style="list-style-type: none"> <li>• Rubber liner worn through. Replace rubber liner.</li> <li>• Vibrator malfunctioning. See vibrator manual.</li> </ul>
Vibrator not working or making excessive noise.	See vibrator manual.
Vibrator tripping overload protection due to high amp draw.	Turn eccentric weight setting down. See vibrator manual.

# Part Numbers

---

This section provides product names and corresponding part numbers for vibrating dribble chute and related equipment. Please reference part numbers when ordering parts.

## *Vibrating Dribble Chutes*

P/N 31546. See Figure 4.

**Martin® Vibrating Dribble Chute Assembly with Control Panel and Overload Protection:** P/N 31546-OL.

## *Dribble Sheets*

31494-XXXXXXX. See Figure 5.

## *Operator's manuals*

**Martin® Zero-Frame Electric Vibrators Operator's Manual:**  
P/N M3892.

## *Miscellaneous*

**Mount Kit for Electric Vibrators:** P/N 32401-XX.

**Electrical Cord 16/4:** P/N 105017. Additional cable for vibrator to switchbox, if needed.

**Electrical Cord 16/3:** P/N 105016. Additional power cable, if needed.

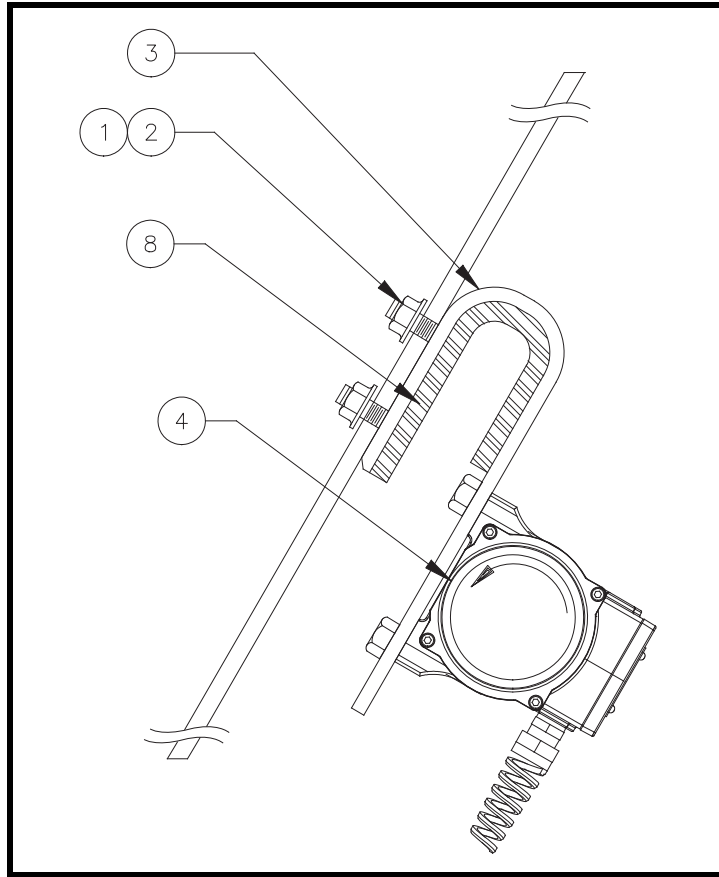

**Figure 4. Martin® Vibrating Dribble Chute Assembly, P/N 31546**

Item	Description	Part No.	Qty.
1	Nut Elastic Lock 1/2 -13NC SS	24307	4
2	Washer 17/32 x 1-1/8 x 1/8 SS	19126	4
3	Dribble Chute Bracket	31496	1
4	Vibrator	MM00U02*	1
5 (NS)	Screw HHC 5/16 -24 x 1-3/4 ZP	11658	4
6 (NS)	Washer Lock 5/16	M209	4
7 (NS)	Nut Hex 5/16 -24 ZP	11635	4
8	Dribble Chute Rubber	31497	1
9 (NS)	Operator's Manual	M3232	1
10 (NS)	Washer Flat 5/16 ZP	13847	4
11	Safety Cable Kit	32271	1

\*Contact Martin Engineering or a representative for vibrator and dribble sheet specific to your application.

NS = Not Shown



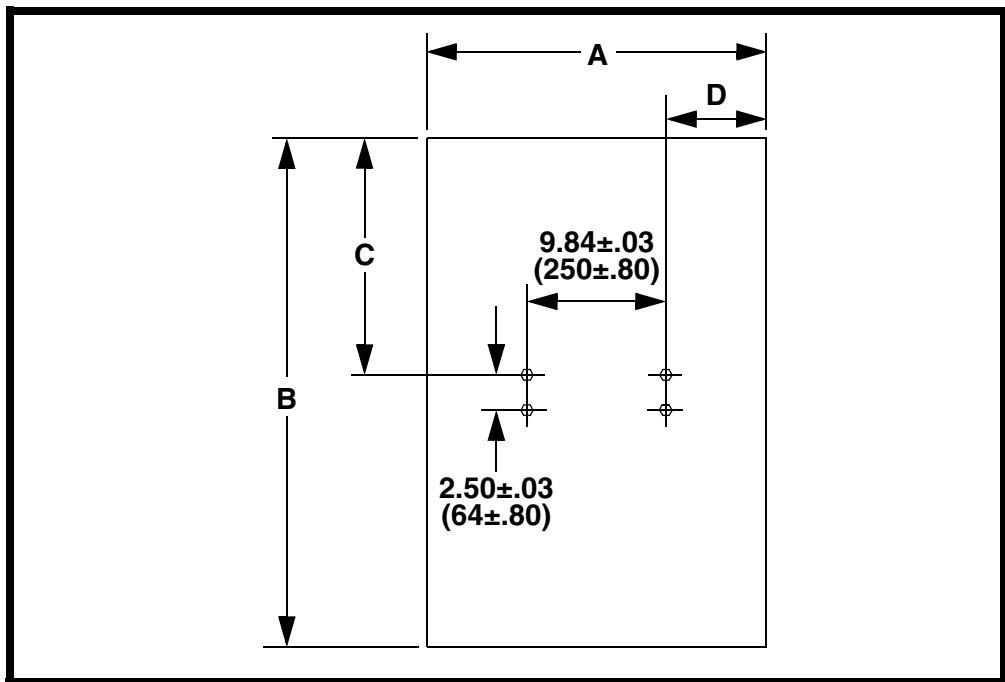

Figure 5. Dribble Sheet, P/N 31494-XXXXXXX\*

Part Number	Dimensions ±0.25 in. (6 mm)				Thickness
	A	B	C	D	
31494-2436XX	24.00 (610)	36.00 (914)	16.75 (425)	7.09 (180)	0.12 (3)
31494-2448XX	24.00 (610)	48.00 (1219)	22.75 (578)	7.09 (180)	0.25 (6)
31494-2460XX	24.00 (610)	60.00 (1524)	28.75 (730)	7.09 (180)	0.50 (13)
31494-3060XX	30.00 (762)	60.00 (1524)	28.75 (730)	10.09 (256)	0.50 (13)
31494-3636XX	36.00 (914)	36.00 (914)	16.75 (425)	13.09 (332)	0.12 (3)
31494-3648XX	36.00 (914)	48.00 (1219)	22.75 (579)	13.09 (332)	0.25 (6)
31494-3660XX	36.00 (914)	60.00 (1524)	28.75 (730)	13.09 (332)	0.50 (13)
31494-3759XX	37.00 (940)	59.06 (1500)	28.28 (718)	13.58 (345)	0.50 (13)
31494-40105XX	40.00 (1016)	105.00 (2667)	51.25 (1302)	15.08 (383)	0.50 (13)
31494-4239XX	42.50 (1080)	39.37 (1000)	18.43 (468)	16.33 (415)	0.50 (13)
31494-4836XX	48.00 (1219)	36.00 (914)	16.75 (425)	19.09 (485)	0.12 (3)
31494-4848XX	48.00 (1219)	48.00 (1219)	22.75 (579)	19.09 (485)	0.25 (6)
31494-4860XX	48.00 (1219)	60.00 (1524)	28.75 (730)	19.09 (485)	0.50 (13)
31494-4872XX	48.00 (1219)	72.00 (1829)	34.75 (883)	19.09 (485)	0.50 (13)
31494-4896XX	48.00 (1219)	96.00 (2438)	46.75 (1187)	19.09 (485)	0.50 (13)
31494-5476XX	54.00 (1372)	76.00 (1930)	36.75 (993)	22.08 (561)	0.50 (13)

\*First XX indicates width; next XXX indicates height; next X indicates material (U = UHMW polyethylene or H = high density polyethylene); last X indicates with or without holes (H = holes or N = none.)



*Any product, process, or technology described here may be the subject of intellectual property rights reserved by Martin Engineering Company. Trademarks or service marks designated with the ® symbol are registered with the U.S. Patent and Trademark Office and may be proprietary in one or more countries or regions. Other trademarks and service marks belonging to Martin Engineering Company in the United States and/or other countries or regions may be designated with the “TM” and “SM” symbols. Brands, trademarks, and names of other parties, who may or may not be affiliated with, connected to, or endorsed by Martin Engineering Company, are identified wherever possible. Additional information regarding Martin Engineering Company’s intellectual property can be obtained at [www.martin-eng.com/trademarks](http://www.martin-eng.com/trademarks).*

# Problem Solved™ GUARANTEED!

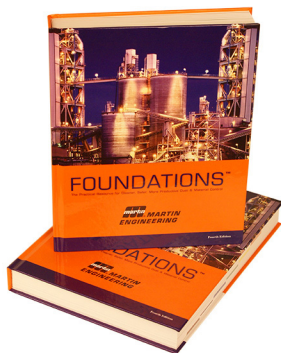

For nearly 20 years, Martin Engineering's Foundations™ Books have taught industry personnel to operate and maintain clean and safe belt conveyors. The Foundations™ Book, fourth edition, focuses on improving belt conveyors by controlling fugitive material. "The Practical Resource for Total Dust and Material Control," is a 576-page hard cover volume that provides information of value to industries where the efficient handling of bulk materials is a key to productivity and profitability.

Expanding upon the book, our Foundations™ Training Program addresses the design and development of more productive belt conveyors, and is offered in three customizable seminars. Attendees gain a better understanding of conveyor safety and performance, helping to justify upgrade investments and increase profitability.



## Martin Engineering USA

One Martin Place  
Neponset, IL 61345-9766 USA  
800 544 2947 or 309 852 2384  
Fax 800 814 1553  
[www.martin-eng.com](http://www.martin-eng.com)

**COMPANY WITH  
QUALITY SYSTEM  
CERTIFIED BY DNV  
= ISO 9001:2008 =**