

# Martin® UBX Secondary Cleaner

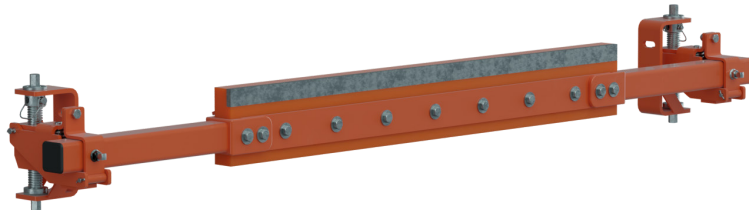

**UBX Secondary Cleaners** utilize a solid, one-piece urethane blade available with or without embedded metal cleaning element to provide highly wear-resistant cleaning performance for long wear life on high-speed, high-tonnage, mine-duty belts. Mechanical spring tensioners require minimal maintenance while providing reliable cleaning performance.

### BENEFITS

- Durable one-piece blade design makes eventual replacement simple.
- Embedded metal blade provides effective and wear-resistant cleaning.
- Compatible with high tonnage, high speed, mine-duty belts.
- Reliable long-life cleaning performance.

### NOMENCLATURE

**UBX-SXX SX X X X X**

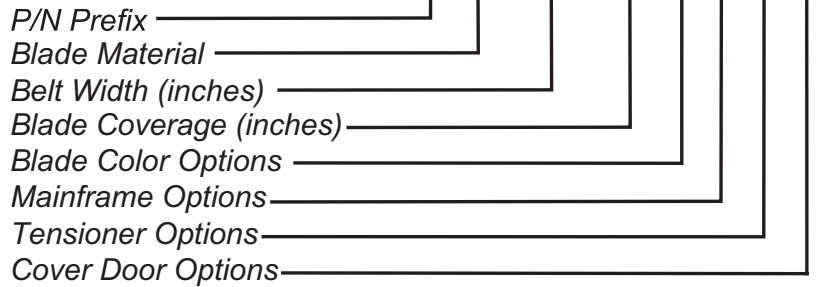

### BLADE MATERIAL

- U:** Urethane Blade
- M:** Metal Tipped Blade

### BELT WIDTH

Belt width in inches:

### BLADE COVERAGE

- S6:** 6.00" Less Belt Width
- SF:** Full Belt Width Coverage

### BLADE COLOR OPTIONS

- O:** Orange
- B:** Brown
- G:** Green

### MAINFRAME OPTIONS

- T:** Painted
- F:** 316 SS

### TENSIONER OPTIONS

- T:** Steel Martin Orange Tensioner
- F:** 316 SS Tensioner
- N:** No Tensioner

### COVER DOOR OPTIONS

- D:** Dust-Tight Steel Cover Door
- S:** Dust-Tight SS Cover Door
- N:** None

### MARTIN® UBX SECONDARY CLEANER URETHANE BLADES

COLOR	GENERAL APPLICATION	Replacement Blade P/N
Orange	Solvent and oil resistant, suitable for most applications -20°F to 160°F [-29°C to 71°C ]	UBUSXXSXOKX
Brown	Chemical and high-moisture resistance -40°F to 160°F [-40°C to 71°C]	UBUSXXSXBKX
Green	High Temperature resistance -40°F to 300°F [-40°C to 149°C]	UBUSXXSXGKX

### MARTIN® UBX SECONDARY CLEANER METAL TIPPED BLADES

COLOR	GENERAL APPLICATION	Replacement Blade P/N
Orange	Solvent and oil resistant, suitable for most application -20°F to 160°F [-29°C to 71°C ]	UBMSXXSXOKX
Brown	Chemical and high-moisture resistance -40°F to 160°F [-40°C to 71°C]	UBMSXXSXBKX
Green	High Temperature resistance -40°F to 300°F [-40°C to 149°C]	UBMSXXSXGKX

## LIMITATIONS

BELT WIDTH - in. [mm]	MAX BELT SPEED - fpm [m/s]
24-72 [610-1829]	1200 [6] and up

## ACCESSORIES

PART	P/N
Martin® UBX Secondary Cleaner Tensioner Steel Painted Martin Orange	UBTT
Martin® UBX Secondary Cleaner Tensioner Assembly 316 SS	UBTF
Martin® UBX Secondary Cleaner Cover Door Steel	UBDT
Martin® UBX Secondary Cleaner Cover Door 316 SS	UBDF

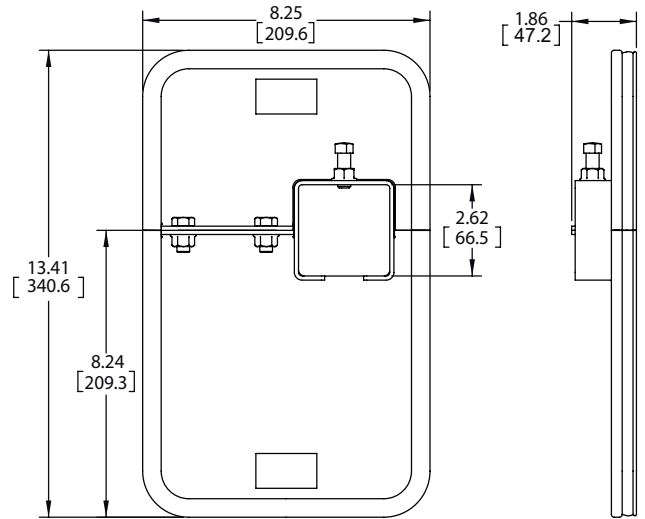

Martin® UBX Secondary Cleaner Cover Door Detail

## DIMENSIONS

MARTIN® UBX CLEANER OPTIONS	Dim "A" - in. [mm]
UBUSXXSXXXXX	4.13 [104.8]
UBMSXXSXXXXX	4.00 [101.6]

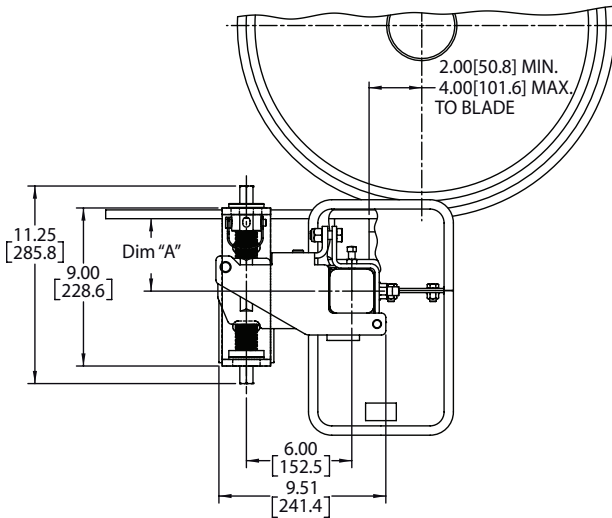

Detail With Tensioner Mounted On Left Side

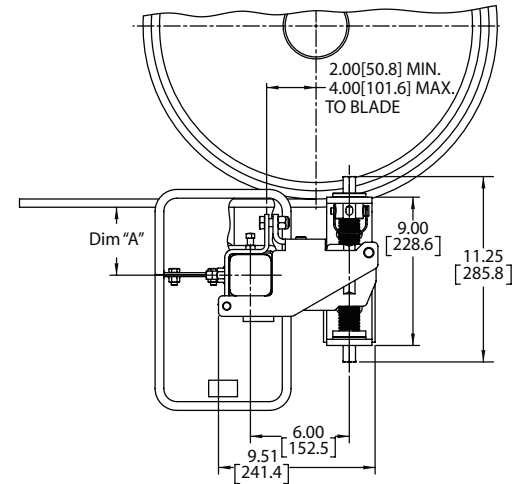

Detail With Tensioner Mounted On Right Side

# TECHNICAL DATA SHEET

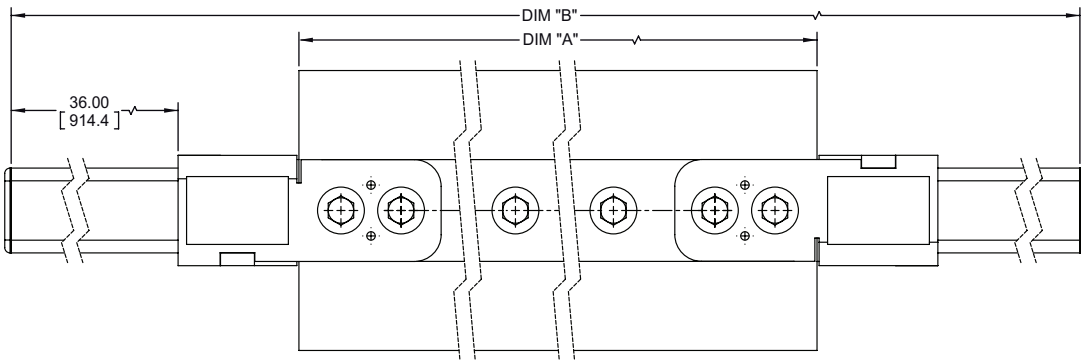

**Martin® UBX Secondary Cleaner Assembly With Urethane Blade Shown Above. P/N: UBUSXXSXXXX**

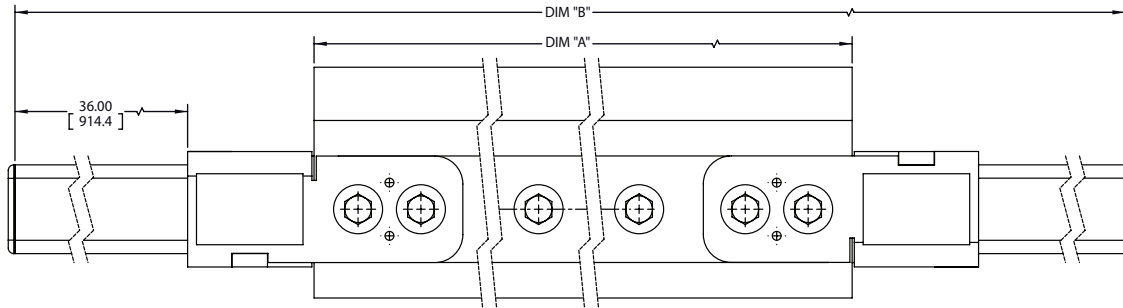
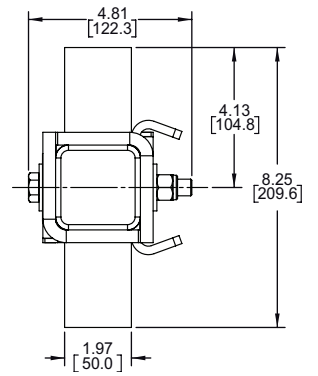

**Martin® UBX Secondary Cleaner Assembly With Metal Blade Shown Above. P/N: UBMSXXSXXXX**

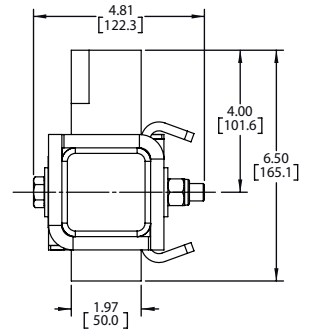

## DIMENSIONS

PART NUMBER	DIM "A"		DIM "B"	
	- in.	[mm]	- in.	[mm]
UBXS24SFXXXX	24.00	[609.6]	103.12	[2619.3]
UBXS30S6XXXX	24.00	[609.6]	103.12	[2619.3]
UBXS30SFXXXX	30.00	[762.0]	109.12	[2771.7]
UBXS36S6XXXX	30.00	[762.0]	109.12	[2771.7]
UBXS36SFXXXX	36.00	[914.4]	115.12	[2924.1]
UBXS42S6XXXX	36.00	[914.4]	115.12	[2924.1]
UBXS42SFXXXX	42.00	[1066.8]	121.12	[3076.5]
UBXS48S6XXXX	42.00	[1066.8]	121.12	[3076.5]
UBXS48SFXXXX	48.00	[1219.2]	127.12	[3228.9]
UBXS54S6XXXX	48.00	[1219.2]	127.12	[3228.9]
UBXS54SFXXXX	54.00	[1371.6]	133.12	[3381.3]
UBXS60S6XXXX	54.00	[1371.6]	133.12	[3381.3]
UBXS60SFXXXX	60.00	[1524.0]	139.12	[3533.7]
UBXS66S6XXXX	60.00	[1524.0]	139.12	[3533.7]
UBXS72SFXXXX	72.00	[1828.8]	151.12	[3838.5]



### Martin Engineering USA

One Martin Place  
 Neponset, IL 61345-9766 USA  
 800 544 2947 or 309 852 2384  
 Fax 800 814 1553  
 www.martin-eng.com

**COMPANY WITH  
 QUALITY SYSTEM  
 CERTIFIED BY DNV GL  
 = ISO 9001 =**

**Problem Solved™ GUARANTEED!**

Form No. L4208-12/24  
 © Martin Engineering Company 2024