

Martin® Impacting Railcar Opener

The [Martin® Impacting Railcar Opener](#) is a powerful solution to improve the efficiency and safety of railcar unloading. It easily opens tough railcar hopper gates, without damage or backbreaking labor.

Keep Unloading Operations Efficient & Safe

- No More Stalled Operations Due to Stubborn Gates
- No More Excess Labor Needed to Force Open Gates
- No More Back Injuries From Trying to Muscle Open Gates

BENEFITS

- Powerful**
 Provides up to 10,000 ft-lbs (1382 kg-m) of impacting torque at 90 psi, to open the most stubborn hopper car gate.
- Adjustable Height**
 Capstan drive height can be adjusted from 7.23–25 inches to fit various car gates and compensate for variations in unloading platforms.
- Ergonomic**
 Balanced wheeled cart can be positioned by one worker. Handle easily adjusts to suit operator preference.
- Steel Tube Frame**
 Rugged construction provides long life in “real world” conditions.
- Durable Tires**
 “Flat Free” tires maneuver easily over rough rail side conditions.
- Pivoting Wheels**
 One lever rotates wheels 90 degrees, so opener can maintain contact with traveling capstan.
- Greasable Tool**
 Impacting tool can be greased to extend the life of internal wear parts.



SPECIFICATIONS

Air Consumption	130 cfm at 90 psi (61.4 l/s at 6.21 bar)
------------------------	---

ORDER INFORMATION

Part Number	Shipping Weight
RO10080	575 lbs (261 kg)

OPTIONAL ACCESSORY

Part Number	Description
RO10089	Air Filter Assembly 1" NPT with Ball Valve and Mount Bracket

TECHNICAL DATA SHEET

DIMENSIONS—in. (mm)

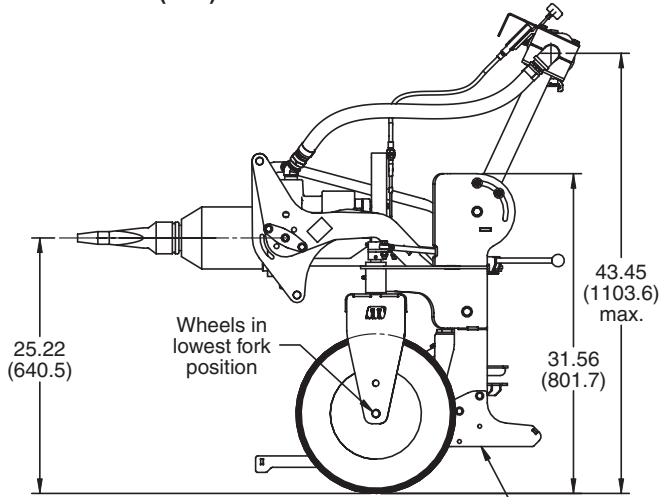

Maximum reach with wheels in maximum height position
Park stand in lower position

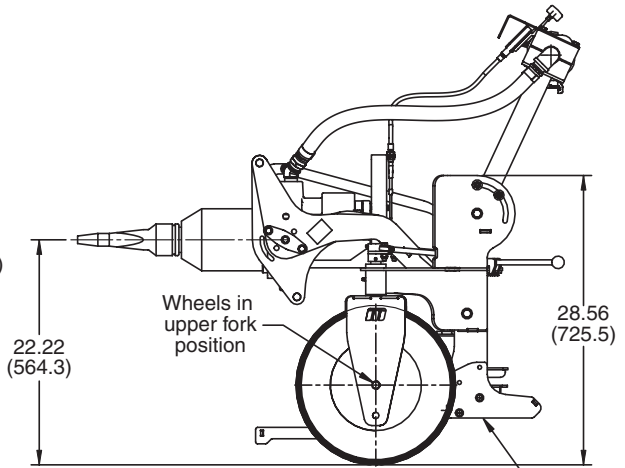

Maximum reach with wheels in minimum height position
Park stand in upper position

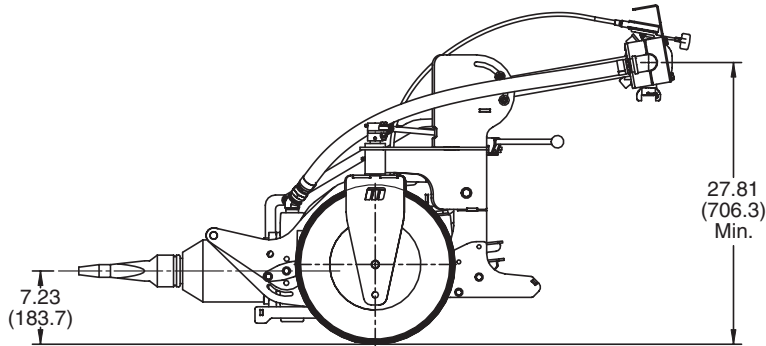

Minimum reach with wheels in minimum height position

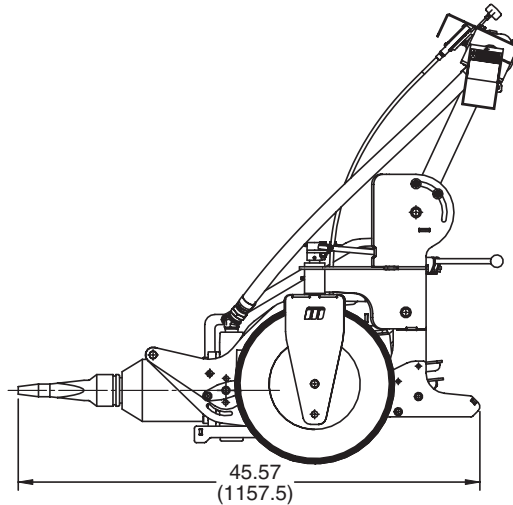
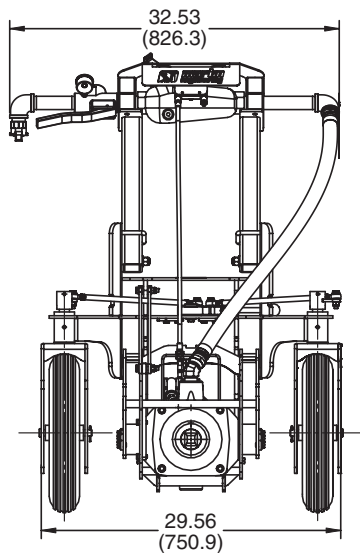

Martin Engineering USA
 One Martin Place
 Neponset, IL 61345-9766 USA
 800 544 2947 or 309 852 2384
 Fax 800 814 1553
www.martin-eng.com

**COMPANY WITH
 QUALITY SYSTEM
 CERTIFIED BY DNV GL
 = ISO 9001 =**

Problem Solved™ GUARANTEED!

Form No. L4147-02/23
 © Martin Engineering Company 2020, 2023