

# Martin® HD QB1™ Cleaner

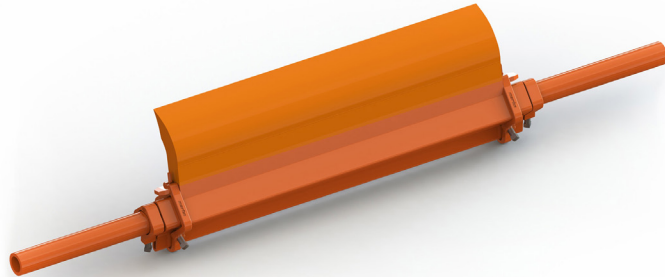

The [Martin® HD QB1™ Cleaner](#) introduces the next generation of belt cleaning technology.

A truly revolutionary innovation in belt cleaning design, the HD QB1™ Cleaner provides the cleanest belt and longest blade life—at the lowest cost.

## FEATURES & BENEFITS

- Same ease of installation as current Martin® QC1™ Cleaners, maintaining standard installation and service costs.
- Utilizes Martin's highly effective, patented CARP profile, ensuring the highest level of cleaning performance expected from a Martin® Belt Cleaner.
- Utilizes Martin's innovative EVO® design principles to reduce component surface exposure to material flow, minimizing material build-up and the resulting clean-up costs, production interruptions and safety concerns.

## SPECIFICATIONS

Maximum Belt Speed fpm (m/sec)	Maximum Service Temperature	Pulley Diameter** in. (mm)	Mounting Location in. (mm)	Wear Life* in. (mm)	Wear Volume (per inch of blade) in <sup>3</sup> (cm <sup>3</sup> )
900 (4.6)	160°F (70°C) Continuous 180°F (82°C) Intermittent	16–22 (406–559)	3.5 (89)	4.5 (114)	6.53 (107)

\* Amount of usable blade

\*\* Pulley diameter 23 in. (584 mm) and greater: contact your Martin Engineering representative.

High-performance urethanes are available; see your Martin Engineering representative for assistance in specifying non-standard products. Refer to Form No. L3375.

## NOMENCLATURE

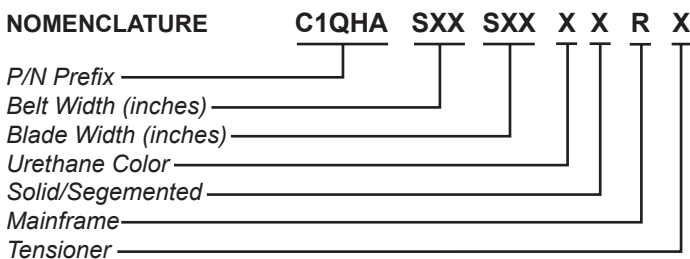

## BLADE LENGTH

- 000: No Blade
- SA0: 100 Inches
- SA2: 102 Inches
- SA4: 104 Inches
- SA8: 108 Inches

## SOLID/SEGMENTED

- 0: Segmented Blade / No Blade
- 1: Solid Blade

## URETHANE COLOR

- 0: No Blade
- B: Brown
- T: Tan
- G: Green
- N: Navy Blue
- O: Orange

## TENSIONER

- T: Martin® Twist Tensioner
- S: Martin® Spring Tensioner

## MOUNTING LOCATION

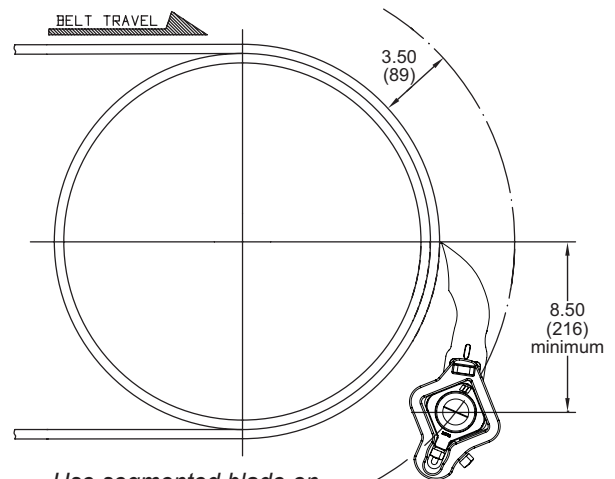

Use segmented blade on crowned head pulley.

# TECHNICAL DATA SHEET

## DIMENSIONS -- in. (mm)

Belt Width in. (mm)	Mainframe Length (B) in. (mm)
18 (400-500)	34 (864)
24 (500-650)	46 (1168)
30 (650-800)	52 (1321)
36 (800-1000)	60 (1524)
42 (1000-1200)	72 (1829)
48 (1200-1400)	78 (1981)
54 (1400-1600)	84 (2134)
60 (1600-1700)	90 (2286)

Belt Width in. (mm)	Mainframe Length (B) in. (mm)
66 (1700-1800)	96 (2438)
72 (1800-2000)	102 (2591)
78 (1800-2000)	108 (2743)
84 (2000-2100)	114 (2896)
90 (2100-2200)	120 (3048)
96 (2200-2400)	126 (3200)
102 (2400-2600)	132 (3374)
108 (2600-2800)	138 (3505)

Note: Dimension A equals belt width minus either 4, 6, or 8 inches.

Dual Tensioners are required for belt widths 54 in. (1400 mm) and greater.

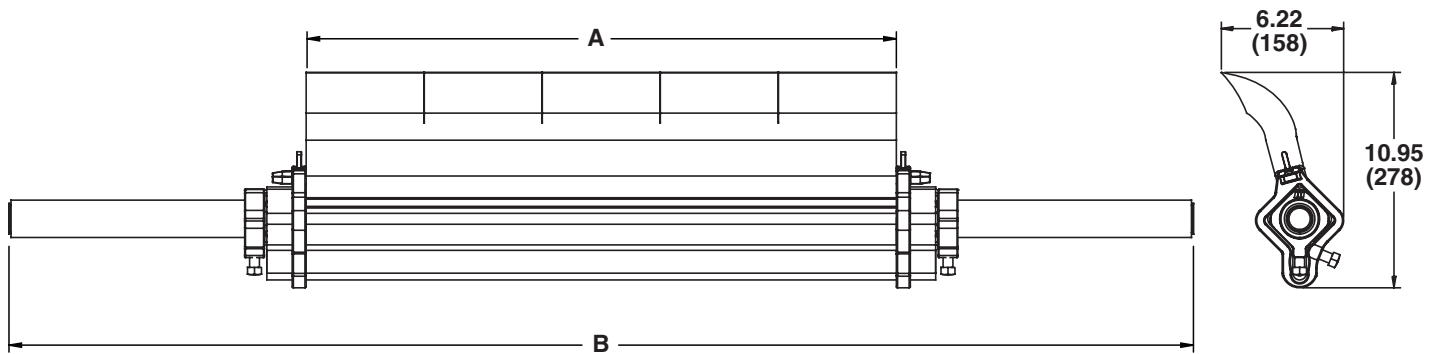

## RECOMMENDED TENSIONERS & REPLACEMENT BLADES

Tensioner	P/N
Martin® Twist Tensioner	38850
Martin® Spring Tensioner	38180

Replacement Blade P/N
C1QHBSXXXX

## ACCESSORIES

Part	P/N
Martin® Steel Inspection Door	CYA-1218
Martin® Hanger Mount Standard Assembly	27382

## FREQUENTLY ASKED QUESTIONS

My Pre-Cleaner keeps flipping through.

*The mounting location may be too far away from the belt. Relocate to the proper dimension.*

*Replace the mainframe or end weldments if they are bent.*

My Pre-Cleaner is wearing more in the center of the blade.

*The blade is too wide for this application. Replace with a shorter length blade.*



### Martin Engineering USA

One Martin Place  
Neponset, IL 61345-9766 USA  
800 544 2947 or 309 852 2384  
Fax 800 814 1553  
www.martin-eng.com

**COMPANY WITH  
QUALITY SYSTEM  
CERTIFIED BY DNV  
= ISO 9001:2008 =**

**Problem Solved™ GUARANTEED!**

Form No. L4103-01/19

© Martin Engineering Company 2018, 2019