

Martin® ATU Pneumatic Turbine Vibrator Series



FEATURES

- No lubrication required
- Low noise level
62–78 dBA well below OSHA standards
- Durable anodized aluminum finish
- Muffler standard
- Lower air consumption than comparable air vibrators
- Direct interchange with competitors' models
- Excellent power to weight ratio
- 250°F temperature rating

Specify Martin Engineering for:

- Cost effective solutions
- Expert technical assistance
- Complete service and support

ACCESSORIES

Part Number	Description
14824	Ball Valve 1/2" NPT
37889	Filter, Regulator Combination, 1/2" NPT
38902-20	On/Off Cycle Timer 115/1/60
36343-NC	Solenoid Valve 115/1/60, 1/2" NPT
36528-NC	Solenoid Valve NC 24V DC Pilot Operate
220691-2.77-250	Mount Kit for ATU-21, 22, 23
220691-3.75-375	Mount Kit for ATU-31, 32, 33
220691-4.5-375	Mount Kit for ATU-41, 42, 43
220691-5.5-500	Mount Kit for ATU-51, 52, 53
220691-6.5-625	Mount Kit for ATU-61, 62, 63

TECHNICAL DATA SHEET

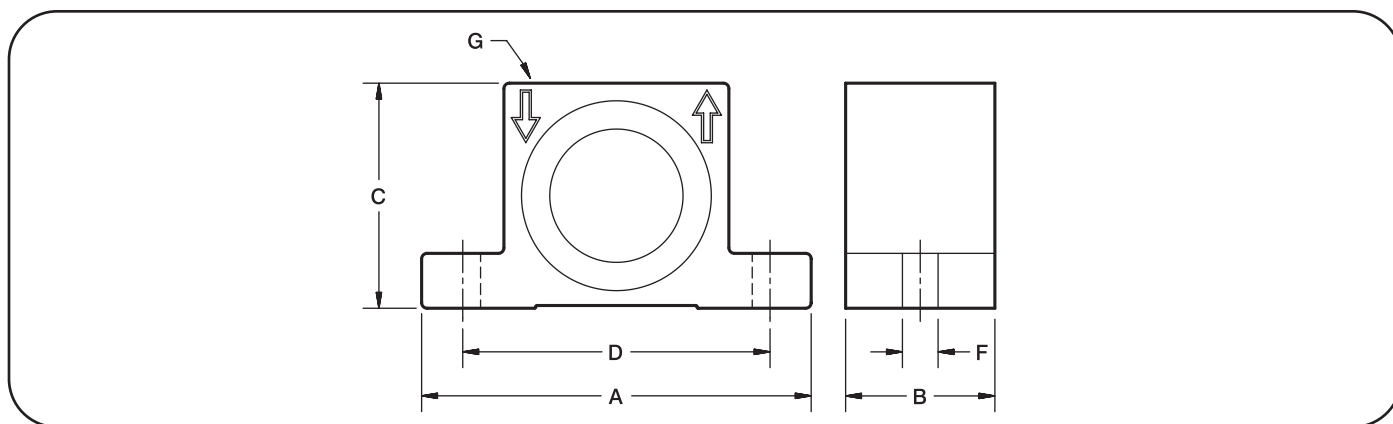

DIMENSIONS (inch)

Model	A	B	C	Bolt Pattern	Bolt Size	Port NPT	Weight lbs
				D	F	G	
ATU-21	3.50	1.32	2.00	2 5/8	1/4	1/8	0.58
ATU-22	3.50	1.32	2.00	2 5/8	1/4	1/8	0.60
ATU-23	3.50	1.32	2.00	2 5/8	1/4	1/8	0.62
ATU-31	4.44	1.70	2.56	3 1/2	3/8	1/4	1.28
ATU-32	4.44	1.70	2.56	3 1/2	3/8	1/4	1.32
ATU-33	4.44	1.70	2.56	3 1/2	3/8	1/4	1.34
ATU-41	5.75	2.26	3.15	4	3/8	1/4	2.61
ATU-42	5.75	2.26	3.15	4	3/8	1/4	2.70
ATU-43	5.75	2.26	3.15	4	3/8	1/4	2.83
ATU-51	7.00	2.90	3.95	5	1/2	3/8	5.11
ATU-52	7.00	2.90	3.95	5	1/2	3/8	5.52
ATU-53	7.00	2.90	3.95	5	1/2	3/8	5.91
ATU-61	8.62	3.40	4.72	6	5/8	3/8	8.77
ATU-62	8.62	3.40	4.72	6	5/8	3/8	9.52
ATU-63	8.62	3.40	4.72	6	5/8	3/8	10.22

PERFORMANCE DATA

Model	In. Lbs.	40 PSI				60 PSI				80 PSI			
		VPM	Force Lbs.	CFM	dB (A)	VPM	Force Lbs.	CFM	dB (A)	VPM	Force Lbs.	CFM	dB (A)
ATU-21	0.008	26000	154	1.8	68	30000	204	2.6	71	33000	247	3.3	73
ATU-22	0.010	23000	150	1.8	62	27500	215	2.6	64	30000	256	3.3	67
ATU-23	0.019	16000	138	1.8	60	17500	165	2.6	61	19000	195	3.3	62
ATU-31	0.023	18000	212	4.9	67	22000	316	6.4	67	24000	326	8.1	68
ATU-32	0.028	17000	230	4.9	65	20500	334	6.4	67	23000	421	8.1	70
ATU-33	0.058	12000	237	4.9	65	15000	371	6.4	68	16000	422	8.1	69
ATU-41	0.061	13500	316	6.7	67	16500	472	9.4	67	18500	593	11.7	69
ATU-42	0.090	12000	368	6.7	64	15000	575	9.4	66	16500	696	11.7	67
ATU-43	0.192	—	—	—	—	11700	746	9.4	67	13000	922	11.7	68
ATU-51	0.224	11500	841	10.7	69	13500	1159	15.3	74	14500	1338	19.2	75
ATU-52	0.340	9500	871	10.7	71	11200	1211	15.3	74	12500	1509	19.2	76
ATU-53	0.759	—	—	—	—	7300	1149	15.3	70	8200	1449	19.2	72
ATU-61	0.608	7900	1078	14.4	68	8700	1307	20.3	72	9400	1526	25.5	77
ATU-62	0.857	7000	1193	14.4	68	8100	1597	20.3	74	8700	1842	25.5	76
ATU-63	1.358	—	—	—	—	5600	1209	20.3	74	6100	1435	25.5	77



Martin Engineering USA
 One Martin Place
 Neponset, IL 61345-9766 USA
 800 544 2947 or 309 852 2384
 Fax 800 814 1553
 www.martin-eng.com

**COMPANY WITH
 QUALITY SYSTEM
 CERTIFIED BY DNV GL
 = ISO 9001 =**

Problem Solved™ GUARANTEED!

Form No. L3853-09/23
 © Martin Engineering Company 2012, 2023