

Martin® Washbox™ Cleaning System



Installed as a secondary cleaner along the conveyor's return run, the Martin® Washbox™ Cleaning System provides the ultimate in belt cleaning technology. Each Martin® Washbox™ Cleaning System can be custom-engineered to match your cleaning requirements.

SINGLE CLEANER SYSTEM INCLUDES:

- One Martin® Belt Cleaner
- One Return Roller
- Mounting Hardware
- Two Martin® Inspection Doors, complete side panel, one on each end of the enclosure
- One Spray Bar with nozzles and valves
- Center Discharge Enclosure

DUAL CLEANER SYSTEM INCLUDES:

- Two Martin® Belt Cleaners
- Three Return Rollers
- Mounting Hardware
- Two Martin® Inspection Doors, complete side panel, one on each end of the enclosure
- Four Spray Bars with nozzles and valves
- Center Discharge Enclosure

NOTES

Martin Engineering recommends use of a pre-cleaner in conjunction with all Martin® Washbox™ Cleaning System installations.

Return idler must be installed directly before Martin® Washbox™ Cleaning System to ensure belt alignment for proper cleaning operation.

The Martin® Washbox™ Cleaning System features nozzles with an orifice size of 0.091 in. (2311 microns) and requires a 10 mesh (2000 micron) filter to prevent direct nozzle plugging.

Consult Martin Engineering for installations with a slope of greater than 15 degrees and for special systems including different cleaning options, drying modules, and squeegee modules.

SPECIFICATIONS: WATER CONSUMPTION

(approximate) gallons per minute (L/min)

Belt Width	Total Nozzles	Pressure PSI (bar)						
		5 (0.34)	10 (0.69)	15 (1.03)	20 (1.38)	30 (2.07)	40 (2.76)	60 (4.14)
18 (400-500)	10	5 (20)	8 (28)	9 (35)	11 (42)	13 (49)	15 (57)	18 (68)
24 (500-650)	10	5 (20)	8 (28)	9 (35)	11 (42)	13 (49)	15 (57)	18 (68)
30 (650-800)	14	7 (28)	11 (40)	13 (49)	15 (58)	18 (69)	21 (79)	25 (95)
36 (800-1000)	14	7 (28)	11 (40)	13 (49)	15 (58)	18 (69)	21 (79)	25 (95)
42 (1000-1200)	16	8 (32)	12 (45)	15 (56)	18 (67)	21 (79)	24 (91)	29 (109)
48 (1200-1400)	20	11 (40)	15 (57)	18 (70)	22 (83)	26 (98)	30 (114)	36 (136)
54 (1400-1600)	22	12 (44)	17 (62)	20 (77)	24 (92)	29 (108)	33 (125)	40 (150)
60 (1600-1800)	22	12 (44)	17 (62)	20 (77)	24 (92)	29 (108)	33 (125)	40 (150)
72 (1800-2000)	26	14 (52)	20 (74)	24 (91)	29 (108)	34 (128)	39 (148)	47 (117)
84 (2000-2200)	28	16 (60)	23 (85)	28 (104)	33 (125)	39 (148)	45 (170)	54 (204)

Consumption is approximate and intended for reference only. Recommended water pressure is 10 psi (0.69 bar).

TECHNICAL DATA SHEET

Martin® Washbox Cleaning System with dual belt cleaners for 18–48 in. belts

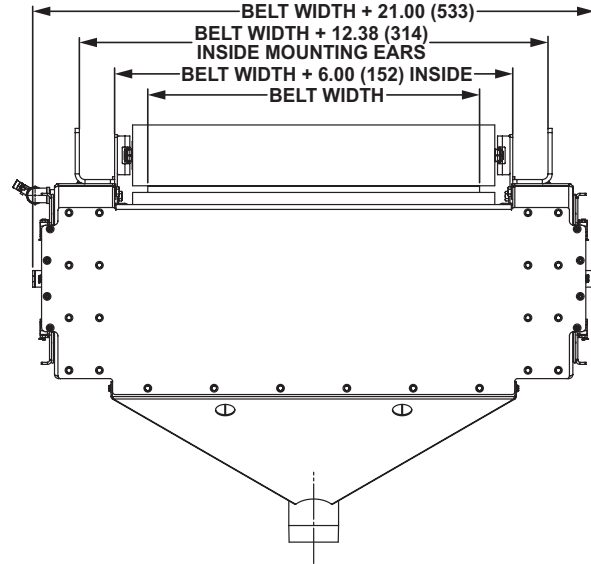
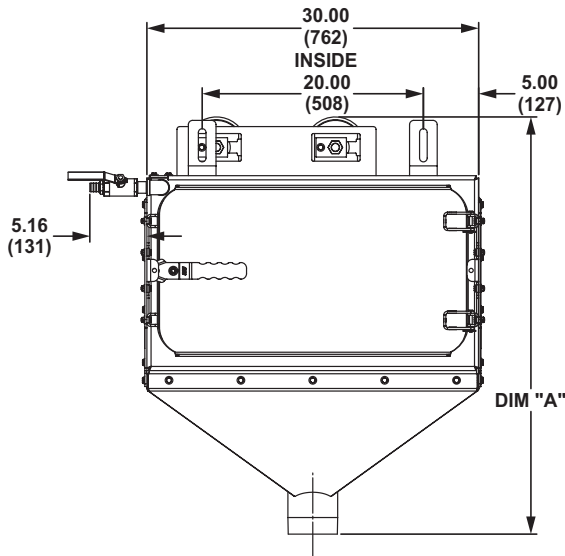

DIMENSIONS

P/N	Dim. "A" in. (mm)
WBX18XXXXXXXXXX	34.35 (872)
WBX24XXXXXXXXXX	36.10 (917)
WBX30XXXXXXXXXX	37.72 (958)
WBX36XXXXXXXXXX	39.35 (999)
WBX42XXXXXXXXXX	41.03 (1042)
WBX48XXXXXXXXXX	42.63 (1083)

NOMENCLATURE — WB X XX X XX X X XX X X

- Part Number Prefix
- The first X indicates the material:
P = Powder Coated Steel
S = Stainless Steel
- The next XX indicates belt width (18-84).
- The next X indicates first belt cleaner type:
A = WSQC2S-XXXXXXXX cleaner
B = WSQC2S-XXXXXX3XX cleaner
C = WH2OS-XXXXXXXX cleaner
Ø = No cleaner
- The next XX indicates first cleaner blade width (12-84).
- The next X indicates first cleaner blade type:
C = WSQC2S with SC-XXR & Rubber Buffer
R = WSQC2S with SC-XXR Orange Blade & Rubber Buffer
T = WSQC2S-XXXXXX3XX with Tungsten Carbide Blade
U = WSQC2S-XXXXXX3XX & WH2OS with Urethane Blade
Ø = No Blade
- The next X indicates the first cleaner blade color:
B = Brown Blade (WSQC2S-XXXXXX3XX)
G = Green Blade (WSQC2S-XXXXXX3XX)
N = Navy Blue Blade (WSQC2S-XXXXXX3XX)
O = Orange Blade (WSQC2S-XXXXXX3XX & WSQC2S-XXXXXXXX)
T = Teal Blade (WH2OS)
Ø = No Blade
- The next X indicates second belt cleaner type:
A = WSQC2S-XXXXXXXX cleaner
B = WSQC2S-XXXXXX3XX cleaner
C = WH2OS-XXXXXXXX cleaner
Ø = No cleaner
- The next XX indicates second cleaner blade width (12-84).
- The next X indicates second cleaner blade type:
C = WSQC2S with SC-XXC & Rubber Buffer
R = WSQC2S with SC-XXR Orange Blade & Rubber Buffer
T = WSQC2S-XXXXXX3XX with Tungsten Carbide Blade
U = WSQC2S-XXXXXX3XX & WH2OS with Urethane Blade
Ø = No Blade
- The next X indicates the second cleaner blade color:
B = Brown Blade (WSQC2S-XXXXXX3XX)
G = Green Blade (WSQC2S-XXXXXX3XX)
N = Navy Blue Blade (WSQC2S-XXXXXX3XX)
O = Orange Blade (WSQC2S-XXXXXX3XX & WSQC2S-XXXXXXXX)
T = Teal Blade (WH2OS)
Ø = No Blade

TECHNICAL DATA SHEET

Martin® Washbox Cleaning System with dual belt cleaners and dual outlet funnels for 54–84 in. belts

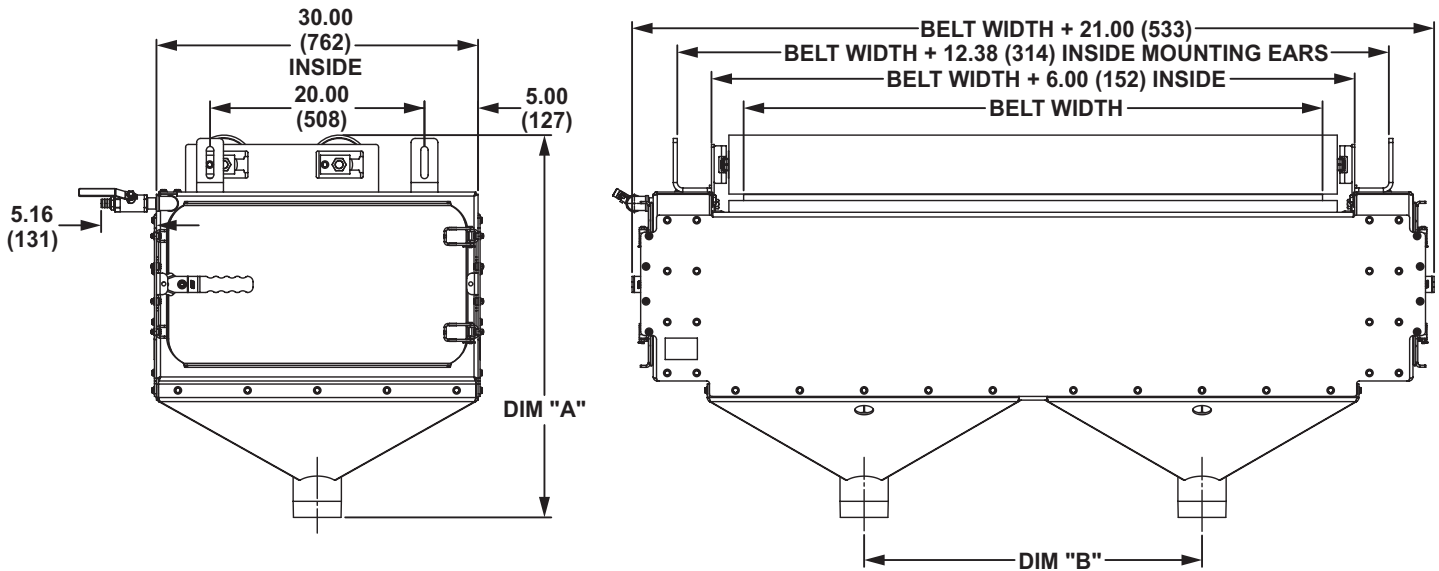

DIMENSIONS

P/N	Dim. "A" in. (mm)	Dim. "B" in. (mm)
WBX54XXXXXXXXXX	35.66 (906)	31.52 (801)
WBX60XXXXXXXXXX	36.53 (928)	34.52 (877)
WBX72XXXXXXXXXX	38.25 (972)	40.51 (1029)
WBX84XXXXXXXXXX	39.85 (1012)	46.51 (1181)

NOMENCLATURE — WB X XX X XX X X X X X X

1 2 3 4 5 6 7 8 9 10 11

- Part Number Prefix
- The first X indicates the material:
P = Powder Coated Steel
S = Stainless Steel
- The next XX indicates belt width (18-84).
- The next X indicates first belt cleaner type:
A = WSQC2S-XXXXXXXX cleaner
B = WSQC2S-XXXXXX3XX cleaner
C = WH2OS-XXXXXXXX cleaner
Ø = No cleaner
- The next XX indicates first cleaner blade width (12-84).
- The next X indicates first cleaner blade type:
C = WSQC2S with SC-XXR & Rubber Buffer
R = WSQC2S with SC-XXR Orange Blade & Rubber Buffer
T = WSQC2S-XXXXXX3XX with Tungsten Carbide Blade
U = WSQC2S-XXXXXX3XX & WH2OS with Urethane Blade
Ø = No Blade
- The next X indicates the first cleaner blade color:
B = Brown Blade (WSQC2S-XXXXXX3XX)
G = Green Blade (WSQC2S-XXXXXX3XX)
N = Navy Blue Blade (WSQC2S-XXXXXX3XX)
O = Orange Blade (WSQC2S-XXXXXX3XX & WSQC2S-XXXXXXXX)
T = Teal Blade (WH2OS)
Ø = No Blade
- The next X indicates second belt cleaner type:
A = WSQC2S-XXXXXXXX cleaner
B = WSQC2S-XXXXXX3XX cleaner
C = WH2OS-XXXXXXXX cleaner
Ø = No cleaner
- The next XX indicates second cleaner blade width (12-84).
- The next X indicates second cleaner blade type:
C = WSQC2S with SC-XXC & Rubber Buffer
R = WSQC2S with SC-XXR Orange Blade & Rubber Buffer
T = WSQC2S-XXXXXX3XX with Tungsten Carbide Blade
U = WSQC2S-XXXXXX3XX & WH2OS with Urethane Blade
Ø = No Blade
- The next X indicates the second cleaner blade color:
B = Brown Blade (WSQC2S-XXXXXX3XX)
G = Green Blade (WSQC2S-XXXXXX3XX)
N = Navy Blue Blade (WSQC2S-XXXXXX3XX)
O = Orange Blade (WSQC2S-XXXXXX3XX & WSQC2S-XXXXXXXX)
T = Teal Blade (WH2OS)
Ø = No Blade

TECHNICAL DATA SHEET

Martin® Washbox Cleaning System with single belt cleaner for 18–48 in. belts

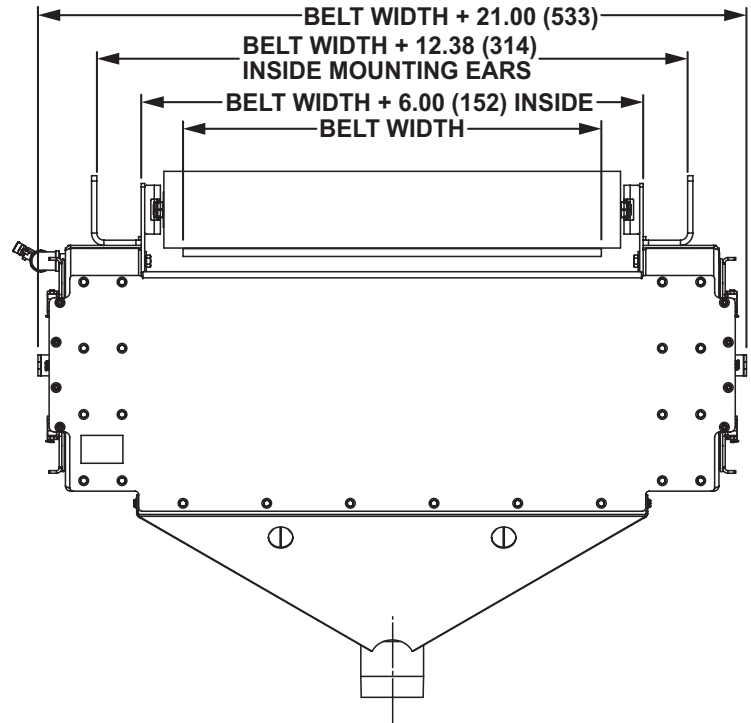
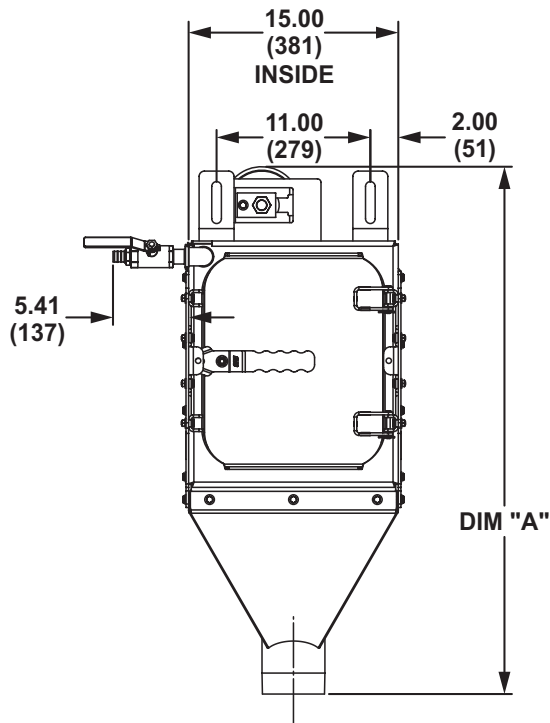

DIMENSIONS

P/N	Dim. "A" in. (mm)
WBSCX18XXXXX	34.35 (872)
WBSCX24XXXXX	36.10 (917)
WBSCX30XXXXX	37.72 (958)
WBSCX36XXXXX	39.35 (999)
WBSCX42XXXXX	41.03 (1042)
WBSCX48XXXXX	42.63 (1083)

NOMENCLATURE — WBSC X XX X XX X X 1 2 3 4 5 6 7

- Part Number Prefix
- The first X indicates the material:
P = Painted Steel
S = Stainless Steel
- The next XX indicates belt width (18-84).
- The next X indicates belt cleaner type:
A = WSQC2S-XXXXXXXXXX cleaner
B = WSQC2S-XXXXXXXX3XX cleaner
C = WH2OS-XXXXXXXXXX cleaner
Ø = No cleaner
- The next XX indicates cleaner blade width (18-84).
- C = WSQC2S with SC-XXC & Rubber Buffer
R = WSQC2S with SC-XXR Orange Blade & Rubber Buffer
T = WSQC2S-XXXXXXXX3XX with Tungsten Carbide Blade
U = WSQC2S-XXXXXXXX3XX & WH2OS with Urethane Blade
Ø = No Blade
- The next X indicates the second cleaner blade color:
B = Brown Blade (WSQC2S-XXXXXXXX3XX)
G = Green Blade (WSQC2S-XXXXXXXX3XX)
N = Navy Blue Blade (WSQC2S-XXXXXXXX3XX)
O = Orange Blade (WSQC2S-XXXXXXXX3XX & WSQC2S-XXXXXXXXXX)
T = Teal Blade (WH2OS)
Ø = No Blade

Martin® Washbox Cleaning System with single belt cleaner and dual outlet funnels for 54–84 in. belts

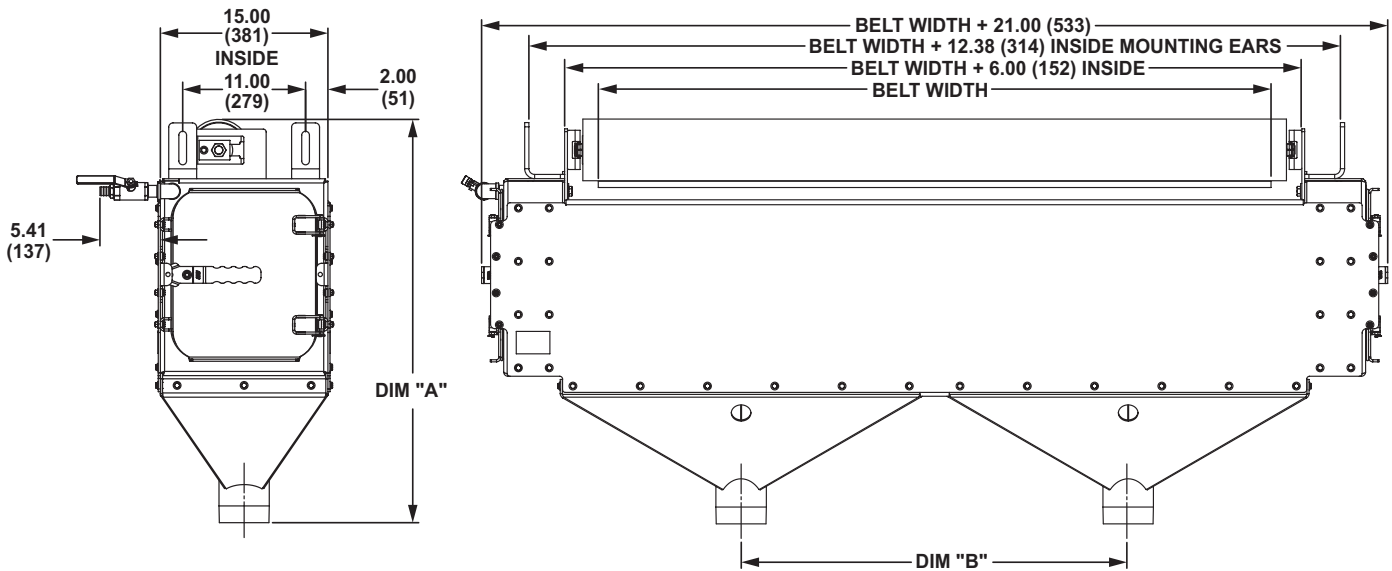

DIMENSIONS

P/N	Dim."A" in. (mm)	Dim."B" in. (mm)
WBSCX54XXXXXXXX	35.35 (898)	31.52 (801)
WBSCX60XXXXXXXX	36.10 (917)	34.52 (877)
WBSCX72XXXXXXXX	37.60 (955)	40.52 (1029)
WBSCX84XXXXXXXX	39.10 (993)	46.52 (1182)

NOMENCLATURE — WBSC X XX X XX X X

- Part Number Prefix
- The first X indicates the material:
P = Painted Steel
S = Stainless Steel
- The next XX indicates belt width (18-84).
- The next X indicates belt cleaner type:
A = WSQC2S-XXXXXXXXX cleaner
B = WSQC2S-XXXXXX3XX cleaner
C = WH2OS-XXXXXXXXX cleaner
Ø = No cleaner
- The next XX indicates cleaner blade width (18-84).
- C = WSQC2S with SC-XXC & Rubber Buffer
R = WSQC2S with SC-XXR Orange Blade & Rubber Buffer
T = WSQC2S-XXXXXX3XX with Tungsten Carbide Blade
U = WSQC2S-XXXXXX3XX & WH2OS with Urethane Blade
Ø = No Blade
- The next X indicates the second cleaner blade color:
B = Brown Blade (WSQC2S-XXXXXX3XX)
G = Green Blade (WSQC2S-XXXXXX3XX)
N = Navy Blue Blade (WSQC2S-XXXXXX3XX)
O = Orange Blade (WSQC2S-XXXXXX3XX & WSQC2S-XXXXXXXXX)
T = Teal Blade (WH2OS)
Ø = No Blade



Martin Engineering USA
 One Martin Place
 Neponset, IL 61345-9766 USA
 800 544 2947 or 309 852 2384
 Fax 800 814 1553
 www.martin-eng.com

**COMPANY WITH
 QUALITY SYSTEM
 CERTIFIED BY DNV
 ISO 9001**