

Martin® Whirlwind High-Frequency Turbine Vibrator

The [Martin® Whirlwind High-Frequency Turbine Vibrator](#) produces more power with less noise than any other high-force/high-frequency pneumatic turbine vibrator. With an output of over 14,000 lb-f (63 kN), depending on the application, the Martin® Whirlwind High-Frequency Turbine Vibrator doubles the force output of the most powerful competitive models. Units mount easily to cradle lug brackets or railcar wedge brackets, and operate quietly to meet OSHA noise requirements.



Shown with Cradle Lug Bracket P/N 28732.

BENEFITS

- **Moves More Material**
Larger unbalance creates greater force output to move your material.
- **Saves Your Hearing**
Testing shows noise level from 6 to 10 dB less than competitive models and within OSHA noise limits.
- **One-Worker Portability**
Built-in handle provides easy portability for use in railcar unloading or on pre-cast forms applications.
- **Reduces Maintenance Costs**
Long-life, high-speed sealed bearings need no lubrication.
- **Reduces Your Investment**
Longer life and lower air consumption than competitive models cuts your lifetime cost of ownership.

TYPICAL APPLICATIONS

- **Concrete Consolidation**
Allows fast placement and high-strength consolidation, provides excellent surface finish. High force reduces the number of vibrators required per form; low air consumption cuts operating costs.
- **Railcar Unloading**
High frequency and high force provide efficient unloading of compacted fine powders like dry chemicals or foodstuffs.
- **Permanent or Portable Mounting**
For applications like material compaction, storage vessel evacuation, or material feeding.

SPECIFICATIONS

Part Number	PSI (bar)	Unbalance in-lb (cm-kg)	VPM	Force lb (kg)	dba	cfm (L/m)
37628	40 (2.67)	4.4 (5.06)	6500	5280 (2394)	72	21 (595)
	60 (4.14)		8400	8820 (4000)	74	25 (708)
	80 (5.52)		10,100	12,753 (5784)	76	28 (793)
37628-HD	40 (2.67)	4.85 (5.59)	6500	5820 (2640)	72	21 (595)
	60 (4.14)		8400	9720 (4408)	74	25 (708)
	80 (5.52)		10,100	14,050 (6373)	76	28 (793)

TECHNICAL DATASHEET

DIMENSIONS—in. (mm)

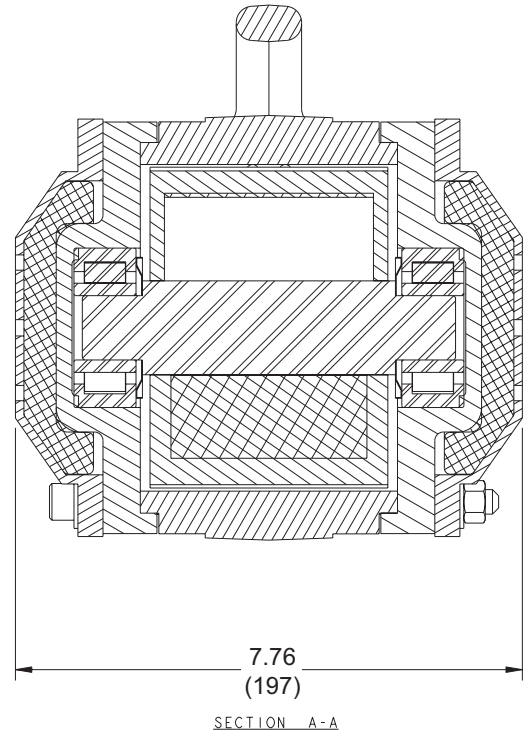
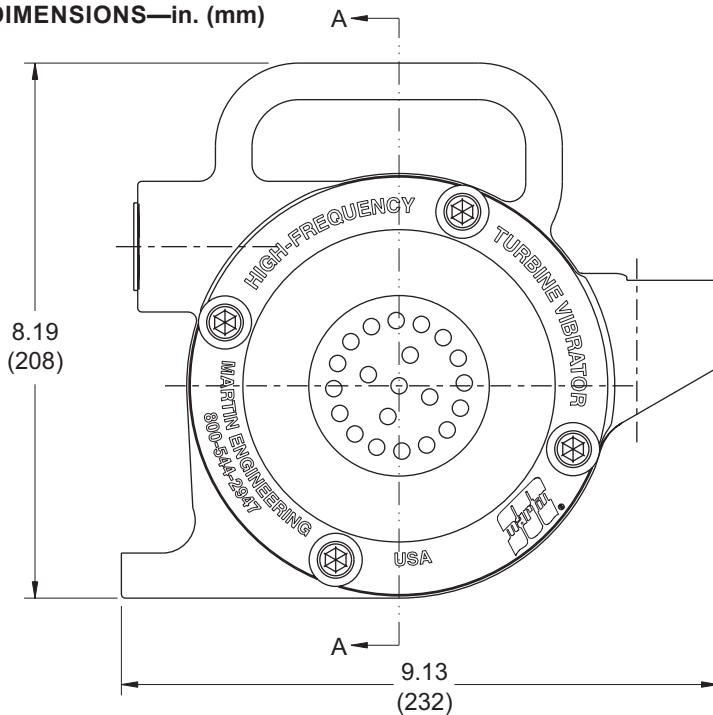

ORDER INFORMATION

	Part Number	Shipping Weight lb (kg)
Vibrator—Standard	37628	40 (18.1)
Vibrator—Heavy-Duty	37628-HD	41 (18.6)
Vibrator—Standard w/Cradle Lug Bracket	37628-C	50 (22.7)
Vibrator—Heavy-Duty w/Cradle Lug Bracket	37628-CHD	51 (23.1)
Vibrator—Standard w/Wedge Bracket	37628-W	65 (29.5)
Vibrator—Heavy-Duty w/Wedge Bracket	37628-WHD	66 (30)

ACCESSORIES

Part Number	Description
12735	Female Wedge Bracket (LBF)
29551	Male Wedge Bracket (LBM)
28732	Cradle Lug Bracket
22817	Clamp On Cradle Lug Bracket
221151	Bolt On Cradle Lug Bracket
17214	3/4" Ball Valve
37020	1" Ball Valve
38736	Filter, Regulator Combination, 1" NPT

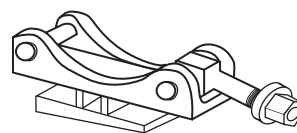

29551

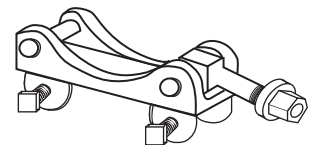

22817

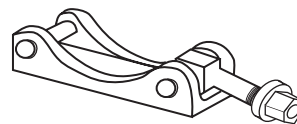

28732

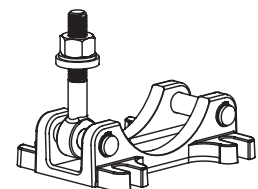

221151



Martin Engineering USA

One Martin Place
Neponset, IL 61345-9766 USA
800 544 2947 or 309 852 2384
Fax 800 814 1553
www.martin-eng.com

**COMPANY WITH
QUALITY SYSTEM
CERTIFIED BY DNV GL
= ISO 9001 =**

Problem Solved™ GUARANTEED!

Form No. L3669-04/22
© Martin Engineering Company 2003, 2022