

MINING *People*

BELTTECH

**SME Annual
Conference & EXPO
Issue**

BELTING
RUBBER
PARTS

Conveyor Idlers



Published by Al Skinner, Inc.

Editor/Publisher

Al Skinner

Ph: 304-342-4129

E-mail: alskinner@ntelos.net

Managing Editor

Christina Martin

Ph: 304-539-2792

E-mail: cpm@ntelos.net

Staff Writer/Field Reporter

Debra McCown

Production Department

E-mail Artwork or Inquiries to:

cpm@ntelos.net

Advertising Sales

Lisa Roper

Phone 864-278-8227

E-mail: lisa.ropер@charter.net

Website Administrator

Chuck Jelderks

Circulation Changes

to cpm@ntelos.net

Corporate Office

304-342-4129

Cell: 304-539-2792

P.O. Box 6247,

Charleston, WV 25362

629 Virginia St., W,

Charleston, WV 25302

Web Portal www.miningpeople.org

Subscribe on-line when visiting Website.

Subscription rate \$25 annually within the United States.

\$50 for Canadian and overseas subscriptions.

Send payment to above address.

Mining People Magazine is mailed direct to mining and aggregates executives with buying power in the United States, Canada, Mexico and overseas. Each copy is mailed specifically to company presidents, CEO's, vice presidents, engineers, purchasing agents, and mine supervisors. Additional copies are distributed at shows, conferences and meetings. Editorial material should be submitted to the editor at the address above by the 15th of the month prior to publication. All original material including advertising design, copy illustrations and signatures conceived and developed by Al Skinner Inc for use by its publication are for express use of this publication. All rights reserved. © Advertising rates and editorial calendars are available upon request by calling Lisa Roper at (864) 278-8227.

BE CLEANER, SAFER AND MORE PRODUCTIVE

Expert Training for More Efficient Conveyor Operation

Martin Engineering, the bulk handling industry's leading authority on conveyor efficiency and productivity, offers you and your team a wide variety of virtual or in-person training and education alternatives conveniently accessible via our online *Foundations™ Learning Center*.

The many training options within the *Learning Center* bridge the theoretical and the practical — providing the information necessary for the proficient operation and maintenance of your conveyor systems.



Proper training is fundamental to reducing potential injuries, fugitive material, premature component failures, and so much more. When your unplanned downtime is minimized, your productivity and profitability are maximized.

Martin Engineering. Learn *why*. Know *how*.

martin
engineering

For direct access to our variety of expert training programs and professional development options, visit martin-eng.com and click **Learning Center**.



Foundations™ Learning Center



THE BLUEFIELD COAL & MINING SHOW

Bluefield, WV, will be held
September 14-16, 2022
www.coctwovirginias.com

Sponsored by:

CHAMBER OF COMMERCE
OF THE
Two Virginias

Features

12



In person 2022 SME Meeting:
“You’ll See A lot of Energy There”

by Debra McCown

SME Exhibitor Profiles30



16



Wyoming CarbonSAFE Project Team
Drills Second Exploratory Well



Conveyor Technology: Designing for the
Future by Innovating the Present22

On the cover...
Belt Tech, Inc. displays products at a past in-person mining event. Photo by Chuck Roper

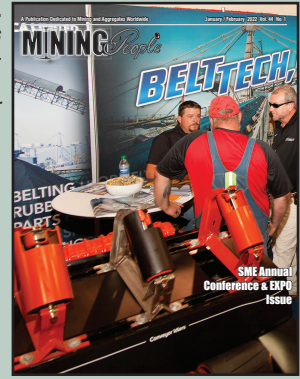

Departments

Buyer-Friendly Ad Index “Find it Fast”	4
Editorial by Debra McCown	6
Mining People Comments	8
Capsule News	18
Worldwide News	24
Energy News	32
Mining People in the News	27
Product News	33
Product Literature	36
Events.....	38
Advertising Index	42
Professional Directory / Classified.....	40-42

In the News

Swanson Industries Opens New Location.....	18
Granite Observes 100th Anniversary.....	19
AngloGold Ashanti Acquires Corvus Gold	20
American Lithium Receives Permit Approvals.....	21
Workforce Training Solutions for Underground Mining in Greece	24
Intelligent Technologies Move China Ahead.....	25
Robots Achieve Historic Underground Mine Inspections.....	26
Barrack’s Tanzania Mines Advancing to Tier One Status	26
Solar Power to Lead in 2022 US Electricity Generation	32

Buyer-Friendly Index

ABRASION / IMPACT RESISTANT MATERIALS
HardSteel, Inc. (39, 40) www.hardsteel.com
BELT CLEANING SYSTEMS
Richwood (17, 40) www.richwood.com
CLEAN BELT SYSTEMS AND SERVICES
Martin Engineering (3)..... www.martin-eng.com
CONTRACTORS
Cowin & Company Inc. (14, 40)..... www.cowin-co.com
CONVEYOR ACCESSORIES
Richwood (40) www.richwood.com
CONVEYORS
Belt Tech, Inc. (11)..... www.belttechinc.com
West River Conveyors and Machine Company (40)
..... www.westriverconveyors.com

DISTRIBUTORS / ENGINEERED PRODUCTS

RM Wilson Co, Inc. (9, 42)	www.rmwilson.com
United Central Industrial Supply Co., Inc. (2) www.unitedcentral.net
EVENTS	
CoalProTec (37)	www.cosalprepsociety.org
SME Annual Conference & Expo (31) www.smeannualconference.com
FULL SERVICE CONTRACTORS	
RWS Resources (41)	www.rwsresources.com
IMPACT SADDLES	
Richwood (41)	www.richwood.com
MINING PRODUCTS & SAFETY	
Jennmar Corp. (44-BC).....	www.jennmarcorp.com
MINING PRODUCTS & EQUIPMENT	
Coalfield Services (41)	www.coalfieldservices.com

MONITORING SOFTWARE / DETECTION

Conspic Controls (15)	www.conspic-controls.com
PNEUMATIC VACUUM PUMPS	
Strata Worldwide (40)	www.strataworldwide.com
PROCESSING EQUIPMENT	
Ceramic Technology (41).....	www.ceramictech.com
RAISE BORING	
Raisebor (41).....	www.raisebor.com
SAMPLING SYSTEMS	
Precision Samplers (42)	www.precision.samplers.com
TIRES	
Setco Tire & Rim Assembly (5, 42)..... www.setcosolidtire.com
WIRELESS COMMUNICATION	
IWT Wireless (7)	www.iwtwireless.com

Conveyor Technology: Designing For the Future by Innovating the Present

by R. Todd Swinderman, CEO Emeritus of Martin Engineering

Higher production demands across all bulk handling segments require increased efficiency at the lowest cost of operation, in the safest and most effective manner possible.

As conveyor systems become wider, faster and longer, more energy output and more controlled throughput will be needed. Add an increasingly stringent regulatory environment, and cost-conscious plant managers must closely review which new equipment and design options align with their long-term goals for the best return on investment (ROI).

Safety at Higher Belt Speeds

Safety is likely to become a new source of cost reduction. The percentage of mines and processing facilities with a robust safety culture are likely to increase over the next 30 years to the point where it is the norm, not the exception. In most cases, with only a marginal adjustment to the belt speed, operators quickly discover unanticipated problems in existing equipment and workplace safety. These problems are commonly indicated by a larger volume of spillage, increased dust emissions, belt misalignment and more frequent equipment wear/failures.

Higher volumes of cargo on the belt can produce more spillage and fugitive material around the system, which can pose a tripping hazard. According to the US Occupational Safety and Health Administration (OSHA), slips, trips and falls account for 15% of all workplace deaths and 25% of all workplace injury claims.[1] Moreover, higher belt speeds make pinch and shear points in the conveyor more dangerous, as reaction times are drastically reduced when a worker gets clothing, a tool or a limb caught from incidental contact.[2]

The faster the belt, the quicker it can wander off its path and the harder it is for a belt tracker to compensate, leading to spillage along the entire belt path. Caused by uncentered cargo, seized idlers or other reasons, the belt can rapidly come in contact with the mainframe, shredding the edge and potentially causing a friction fire. Beyond the workplace safety consequences, the belt can convey a fire throughout the facility at extremely high speed.

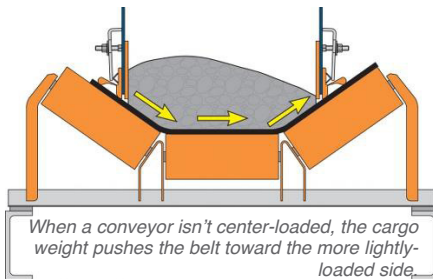

Another workplace hazard -- one that is becoming progressively more regulated -- is dust emissions. An increase in the volume of cargo means greater weight at higher belt speeds, causing more vibration on the system and leading to reduced air quality from dust. In addition, cleaning blade efficiency tends to decline as volumes rise, causing more fugitive emissions during the belt's return. Abrasive particulates can foul rolling components and cause them to seize, raising the possibility of a friction fire and increasing maintenance costs and downtime. Further, lower air quality can result in fines and forced stoppages by inspectors.

Correcting Misalignment Before It Happens

As belts get longer and faster, modern track-

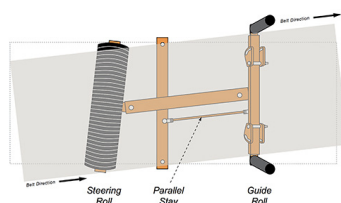

The pivoting ribbed roller design grabs the belt and uses the opposing force to shift it back into alignment.

ing technology becomes mandatory, with the ability to detect slight variations in the belt's trajectory and quickly compensate before the weight, speed and force of the drift can overcome the tracker. Typically mounted on the return and carry sides every 70 to 150 feet (21 to 50 m) -- prior to the discharge pulley on the carry side and the tail pulley on the return -- new upper and lower trackers utilize innovative multiple-pivot, torque-multiplying technology with a sensing arm assembly that detects slight variations in the belt path and immediately adjusts a single flat rubber idler to bring the belt back into alignment.

Modern Chute Design

To drive down the cost per ton of conveyed material, many industries are moving toward wider and faster conveyors. The traditional troughed design will likely remain a standard. But with the push toward wider and higher-speed belts, bulk handlers will need substantial development in more reliable components, such as idlers, impact beds and chutes.

A major issue with most standard chute designs is that they are not engineered to manage escalating production demands. Bulk material unloading from a transfer chute onto a fast-moving belt can shift the flow of material in the chute, resulting in off-center loading, increasing fugitive material spillage and emitting dust well after leaving the settling zone.

STILLING ZONE TRANSFER

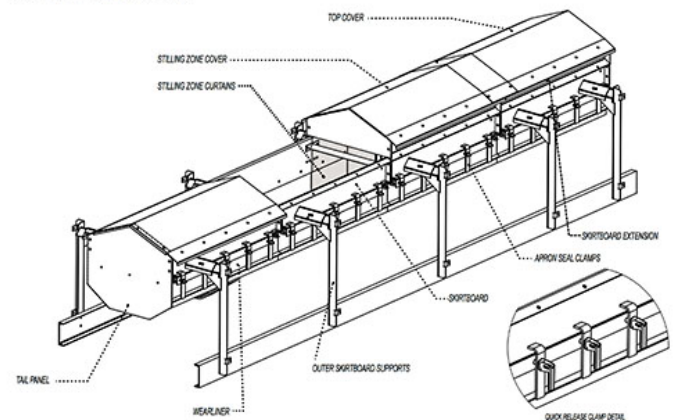

Modern stilling zones feature components designed to reduce maintenance and improve safety.

Newer transfer chute designs aid in centering material onto the belt in a well-sealed environment that maximizes throughput, limits spillage, reduces fugitive dust and minimizes common workplace injury hazards. Rather than material falling with high impact directly onto the belt, the cargo's descent is controlled to promote belt health and extend the life of the impact bed and idlers by limiting the force of the cargo at the loading zone.

Reduced turbulence is easier on the wear liner and skirting and lowers the chance of fugitive material being caught between the skirt and belt, which can cause friction damage and belt fraying.

Longer and taller than previous designs, modular stilling zones allow cargo time to settle, providing more space and time for air to slow down, so dust settles more completely. Modular designs easily accommodate future capacity

modifications. An external wear liner can be changed from outside of the chute, rather than requiring dangerous chute entry as in previous designs. Chute covers with internal dust curtains control airflow down the length of the chute, allowing dust to agglomerate on the curtains and eventually fall back onto the belt in larger clumps. And dual skirt sealing systems have a primary and secondary seal in a two-sided elastomer strip that helps prevent spillage and dust from escaping from the sides of the chute.



overcome. Designed to be self-contained power stations that are retrofitted onto existing idler support structures, these generators can be employed on virtually any steel roller.

A single Roll Generator has enough power output to run a variety of accessories.

Rethinking Belt Cleaning

Faster belt speeds can also cause higher operating temperatures and increased degradation of cleaner blades. Larger volumes of cargo approaching at a high velocity hit primary blades with greater force, causing some designs to wear quickly and leading to more carryback and increased spillage and dust. In an attempt to compensate for lower equipment life, manufacturers may reduce the cost of belt cleaners, but this is an unsustainable solution that doesn't eliminate the additional downtime associated with cleaner servicing and regular blade changes.

As some blade manufacturers struggle to keep up with changing production demands, industry leaders in conveyor solutions have reinvented the cleaner industry by offering heavy-duty engineered polyurethane blades made to order and cut onsite to ensure the freshest and longest lasting product. Using a twist, spring or pneumatic tensioner, the primary cleaners are forgiving to the belt and splice but are still highly effective for dislodging carryback. For the heaviest applications, one primary cleaner design features a matrix of tungsten carbide scrapers installed diagonally to form a 3-dimensional curve around the head pulley. Field service has determined that it typically delivers up to 4x the service life of urethane primary cleaners, without ever needing re-tensioning.

Taking belt cleaner technology into the future, an automated system increases blade life and belt health by removing blade contact with the belt any time the conveyor is running empty. Connected to a compressed air system, pneumatic tensioners are equipped with sensors that detect when the belt no longer has cargo and automatically backs the blade away, minimizing unnecessary wear to both the belt and cleaner. Additionally, it reduces labor for the constant monitoring and tensioning of blades to ensure peak performance. The result is consistently correct blade tension, reliable cleaning performance and longer blade life, all managed without operator intervention.

Power Generation

Systems designed to operate at high speeds over considerable distances are generally powered only at vital locations such as the head pulley, disregarding adequate power for autonomous 'smart systems,' sensors, lights, accessories or other devices along the length of the conveyor. Running auxiliary power can be complicated and costly, requiring transformers, conduits, junction boxes and oversized cables to accommodate the inevitable voltage drop over long runs. Solar and wind can be unreliable in some environments, particularly in mines, so operators require alternative means of reliable power generation. By attaching a patented mini-generator to idlers and using the kinetic energy created by the moving belt, the accessibility obstacles found in powering ancillary systems can now be

The design employs a magnetic coupling that attaches a "drive dog" to the end of an existing roller, matching the outside diameter. Rotated by the movement of the belt, the drive dog engages the generator through the outer housing's machined drive tabs. The magnetic attachment ensures that electrical or mechanical overload does not force the roll to stop; instead, the magnets disengage from the roll face. By placing the generator outside the material path, the innovative new design avoids the damaging effects of heavy loads and fugitive material.

Bulk Handling, Safety and Automation in the Future

Automation is the way of the future, but as experienced maintenance personnel retire, younger workers entering the market will face unique challenges, with safety and maintenance skills becoming more sophisticated and essential. While still requiring basic mechanical knowledge, new maintenance personnel will also need more advanced technical understanding. This division of work requirements will make it difficult to find people with multiple skill sets, driving operators to outsource some specialized service and making maintenance contracts more common.

Conveyor monitoring tied to safety and predictive maintenance will become increasingly reliable and widespread, allowing conveyors to autonomously operate and predict maintenance needs. Eventually, specialized autonomous agents (robots, drones, etc.) will take over some of the dangerous tasks, particularly in underground mining as the ROI for safety provides additional justification.

Ultimately, moving large quantities of bulk materials inexpensively and safely will result in the development of many new and higher capacity semi-automated bulk transfer sites. Previously fed by truck, train or barge, long overland conveyors transporting materials from the mine or quarry site to storage or processing facilities may even impact the transportation sector. Stretching vast distances, these long bulk handling networks have already been built in some places with low accessibility but may soon be commonplace in many areas around the world.

Toll-free: (800) 544-2947
Email: info@martin-eng.com
www.martin-eng.com

References

[1] "Slips, Trips & Falls Identification and Prevention;" *Occupational Safety and Health Administration; Sacramento, CA 2007*. https://www.osha.gov/dte/grant_materials/fy07/sh-16625-07/slipstripsfalls.ppt, [2] Swinderman, Todd; Marti, Andrew D.; Marshall, Daniel: "Foundations for Conveyor Safety;" *Martin Engineering, Section 1*, pg. 14. *Worzalla Publishing Company, Stevens Point, WI 2016*. <https://www.martin-eng.com/content/product/690/safety-book>
© 2022 Martin Engineering Company. All rights reserved. Martin Engineering products are protected by U.S. and foreign patents and patents pending. Additional intellectual property information is provided at www.martin-eng.com/trademarks.