



DRY CARGO

international

25th
anniversary

WWW.DRYCARGOMAG.COM

ISSUE NO. 276 FEBRUARY 2024



Steelpaint-Systems with SP-Zincing

For better cathodic corrosion protection for highly stressed areas on all types of vessels as well as port facilities including container bridges.

FEATURES

■ Global Coal Trades

■ Covered Storage

■ Coal Handling Systems

■ Ships' Agents

■ Offshore Stevedoring & Transshipment

The world's leading and only monthly magazine for the dry bulk industry

Highly responsive conveyor belt tracker



The upper unit of the Tracker HD comes with the specified trough angle of the conveyor system (all photos: ©2024 Martin Engineering).

improves production and safety worldwide

A pioneer in belt conveyor accessories has launched the next generation of tracking technology for a global marketplace. Martin Engineering designed the highly responsive Martin® Tracker™ HD (heavy-duty) belt conveyor alignment system with widely available plate steel to increase availability and affordability across all six continents it serves. A mistracking belt produces excessive spillage which increases labor costs for clean-up and may cause contact with the mainframe. This seriously damages both the belt and the structure and increases the potential for a friction fire. The Martin Tracker HD upper and lower units provide immediate, continuous, and precise adjustment of the mistracking belt. The result is greater productivity with less unscheduled downtime from both equipment replacement and spillage clean-up for a lower cost of operation.

“Since most OEM mistracking devices are only designed to prevent contact with the stringer and don’t actually realign the belt, operators can spend a lot of time monitoring the system and adjusting idlers to achieve consistent alignment,” explained Dave Mueller, Product Manager for Martin Engineering. “With enough manual adjusting, operators find that idlers must be

re-centred if there’s a change in cargo characteristics or to install a new belt. The Tracker HD automates the alignment process, eliminating the need for constant monitoring and manual adjustments, reducing the labour and downtime for maintenance.”

HOW IT WORKS

The Martin Tracker HD’s unrivalled precision comes from sensing rollers that ride either side of the belt edge and are

attached to the end of an arm assembly. As the rollers detect slight variations in the belt path, the force of the wandering belt causes the arms to automatically position a pivoting idler in the opposite direction of the misalignment. The lever action requires less force to initiate the correction and only slight adjustments mean the consistent contact between the belt and idlers reduces the energy needed to bring the belt back into alignment.

“Certain countries can’t buy the square

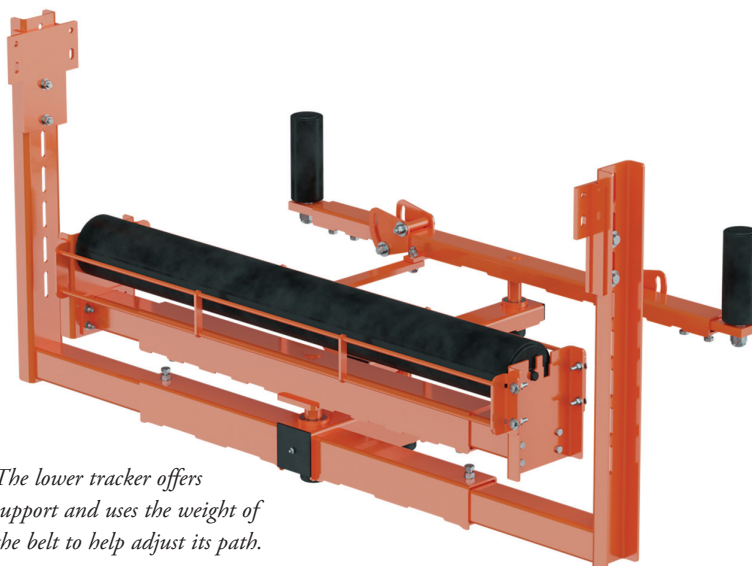

The lower tracker offers support and uses the weight of the belt to help adjust its path.

tubing, so we're now manufacturing the equipment from readily available plate steel without any changes to the performance or life of the unit," Mueller pointed out. "This allows the Tracker HD to be produced and supplied across all global business units."

COMPATIBLE WITH MOST BELT CONVEYOR SYSTEMS

Easy to install and designed to withstand the stress associated with wider, thicker belts moving at higher speeds and carrying heavier loads, the Martin Tracker HD is suitable for a belt thickness up to 1.125in (28.5mm) and speeds up to 800fpm (4m/s). Both the upper and lower units accommodate belt widths of 36–72in (915–1,828 mm) with an effective tracking distance of 150ft (45.72m).

Available in 20°, 35°, and 45° trough angles, there are options for the addition of a Martin® Trac-Mount™ Idler, which allows the entire troughed idler unit to be slid away from the mainframe and safely serviced from outside of the system by a single worker. This important safety element can considerably reduce the amount of labor and maintenance time for the replacement of broken or frozen idlers. Also available are rubber-lagged rollers on the lower tracker and a grease kit for both the upper and lower assemblies. The unit is not suitable for reversing conveyors, belts with substantial rollback, or paddle or chevron belts.

PROPER PLACEMENT IS THE KEY

It is recommended operators install Martin Tracker HDs after the load zone on belts wider than 24in (610mm) with additional units placed down the system to keep the belt centred and tracking. By placing an



The pivoting idler assembly rotates in the opposite direction of the mistracking belt.

upper unit before the discharge, operators ensure the belt is centred on the head pulley allowing for optimal belt cleaning with maximum cargo discharge.

The lower tracker has been redesigned to include an extra safety feature not found in competitor units. Regardless of the conveyor, return rollers have been known to detach and drop, creating a serious safety issue, so the Martin Tracker HD has been equipped with safety guarding on the steering roll to prevent the roller from coming off or putting workers in harm's way. On the return, it is recommended to place a tracker after the discharge zone or take-up pulley, as well as periodically down the system depending on length. To ensure centred loading, the belt must enter the loading zone aligned, so installing a lower unit approximately five times the belt's width in distance from the tail pulley will support an efficient loading process.

FIELD TESTED AND APPROVED

Since the basic design of the Martin Tracker HD is similar to that of its predecessors with square tube construction, the testing

focused on performance, durability and installation time. Tested in bulk handling operations including mining and cement where mistracking leading to spillage had historically been a concern, the unit performed up to Martin Engineering's high standards.

"Martin Engineering believes safety should be a core function in any conveyor accessory we design, and the Tracker HD is no different," Mueller said. "By automating consistent belt tracking, this solution reduces equipment wear, maintenance time, and downtime. These factors lower the cost of operation offering the best return on investment of any tracker on the market."

ABOUT MARTIN ENGINEERING

Martin Engineering has been a global innovator in the bulk material handling industry for more than 80 years, developing new solutions to common problems and participating in industry organizations to improve safety and productivity. The company's series of *Foundations* books is an internationally recognized resource for safety, maintenance and operations training — with more than 22,000 print copies in circulation around the world. The 500+ page reference books are available in several languages and have been downloaded thousands of times as free PDFs from the Martin website. Martin Engineering products, sales, service and training are available from 17 factory-owned facilities worldwide, with wholly-owned business units in Australia, Brazil, China, Colombia, France, Germany, India, Indonesia, Italy, Malaysia, Mexico, Peru, Spain, South Africa, Turkey, the USA and UK. The firm employs more than 1,000 people, approximately 400 of whom hold advanced degrees. 



The torsion rollers ride smoothly on the belt edge detecting slight variations in the belt path.