

ASSEMBLY PART NO.	BELT WIDTH	DIM "A" FRAME LENGTH	DIM "B" CARTRIDGE LENGTH	DIM "C" SPLIT-TRACK LENGTH	DIM "D" BLADE COVERAGE	BLADE QTY
DT2S-18X12XXXX	18.00 [457]	49.50 [1257]	36.16 [918]	27.00 [686]	12.00 [305]	2
DT2S-18X18XXXX	18.00 [457]	49.50 [1257]	36.16 [918]	27.00 [686]	18.00 [457]	3
DT2S-24X18XXXX	24.00 [610]	55.50 [1410]	42.16 [1071]	33.00 [838]	18.00 [457]	3
DT2S-24X24XXXX	24.00 [610]	55.50 [1410]	42.16 [1071]	33.00 [838]	24.00 [610]	4
DT2S-30X24XXXX	30.00 [762]	61.50 [1562]	48.16 [1223]	39.00 [991]	24.00 [610]	4
DT2S-30X30XXXX	30.00 [762]	61.50 [1562]	48.16 [1223]	39.00 [991]	30.00 [762]	5
DT2S-36X30XXXX	36.00 [914]	67.50 [1715]	54.16 [1376]	45.00 [1143]	30.00 [762]	5
DT2S-36X36XXXX	36.00 [914]	67.50 [1715]	54.16 [1376]	45.00 [1143]	36.00 [914]	6
DT2S-42X36XXXX	42.00 [1067]	73.50 [1867]	60.16 [1528]	51.00 [1295]	36.00 [914]	6
DT2S-42X42XXXX	42.00 [1067]	73.50 [1867]	60.16 [1528]	51.00 [1295]	42.00 [1067]	7
DT2S-48X42XXXX	48.00 [1219]	79.50 [2019]	66.16 [1680]	57.00 [1448]	42.00 [1067]	7
DT2S-48X48XXXX	48.00 [1219]	79.50 [2019]	66.16 [1680]	57.00 [1448]	48.00 [1219]	8
DT2S-54X48XXXX	54.00 [1372]	85.50 [2172]	72.16 [1833]	63.00 [1600]	48.00 [1219]	8
DT2S-54X54XXXX	54.00 [1372]	85.50 [2172]	72.16 [1833]	63.00 [1600]	54.00 [1372]	9
DT2S-60X54XXXX	60.00 [1524]	91.50 [2324]	78.16 [1985]	69.00 [1753]	54.00 [1372]	9
DT2S-60X60XXXX	60.00 [1524]	91.50 [2324]	78.16 [1985]	69.00 [1753]	60.00 [1524]	10
DT2S-66X60XXXX	66.00 [1676]	97.50 [2477]	84.16 [2138]	75.00 [1905]	60.00 [1524]	10
DT2S-66X66XXXX	66.00 [1676]	97.50 [2477]	84.16 [2138]	75.00 [1905]	66.00 [1676]	11
DT2S-72X66XXXX	72.00 [1829]	103.50 [2629]	90.16 [2290]	81.00 [2057]	66.00 [1676]	11
DT2S-72X72XXXX	72.00 [1829]	103.50 [2629]	90.16 [2290]	81.00 [2057]	72.00 [1829]	12
DT2S-84X78XXXX	84.00 [2134]	115.50 [2934]	102.16 [2595]	93.00 [2362]	78.00 [1981]	13
DT2S-96X90XXXX	96.00 [2438]	127.50 [3239]	114.16 [2900]	105.00 [2667]	90.00 [2286]	15
DT2S120X114XXXX	120.00 [3048]	151.50 [3848]	138.16 [3509]	129.00 [3277]	114.00 [2896]	19

TENSIONING CHART	
BELT WIDTH	COMPRESSED SPRING LENGTH
18-24 [400-650]	1-5/8 [41]
30-48 [650-1400]	1-1/2 [38]
54-66 [1400-1800]	1-3/4 [45]
72-96 [1800-2400]	1-5/8 [41]
102-120 [2400-3000]	1-1/2 [38]

ITEM	QTY.	DESCRIPTION	PART NUMBER
1	1	DT SPLIT TRACK SECONDARY ASM	DT2S-XXXXXXXS
2	1	INLINE/REV SPRING TENSIONER	37707
3	S/C	REPLACEMENT BLADE	SEE CHART

S/C = SEE CHART

BLADE CHART		
PART NUMBER	DESCRIPTION	BLADE P/N
DT2S-XXRXXXXXX	TC W/SS HOLDER REVERSING	31104-TCSXX
DT2S-XXTXXXXXX	TUNGSTEN CARBIDE REVERSING	31104-TXX
DT2S-XXSXXXXXX	STAINLESS STEEL REVERSING	31104-SXX
DT2S-XXUXXXXXX	URETHANE REVERSING	31104-UXX

- NOTES:
- 1) ALL DIMENSIONS ARE GIVEN IN INCHES (MM).
  - 2) ALL DIMENSIONS ARE FOR REFERENCE PURPOSES ONLY.
  - 3) BOLT OR WELD TENSIONER ASSEMBLY IN PLACE. BOLT TENSIONERS WHEN APPLICABLE FOR EASE OF MAINTENANCE AND ACCESSIBILITY.
  - 4) CENTER BLADES ON BELT SURFACE.
  - 5) WHERE EXTREME OR UNUSUAL CONDITIONS EXIST OR SPECIAL MAINFRAME LENGTHS ARE REQUIRED CONSULT MARTIN ENGINEERING FOR ASSISTANCE.
  - 6) REFER TO OPERATOR'S MANUAL M3687 FOR INSTALLATION INSTRUCTIONS.
  - 7) IF INSTALLED ON CROWN PULLEY, CLEANER IS RECOMMENDED TO BE 4.00 (102) FROM THE CENTERLINE. IT IS IMPORTANT THAT THE BELT IS LEVEL. IF IT IS NOT, INCREASE DIMENSION UNTIL LEVEL.
  - 8) CLEANER MUST BE MOUNTED WITH BLADES PERPENDICULAR TO BELT SURFACE.
  - 9) MAXIMUM ADJUSTMENT OF THE MAINFRAME AT THIS LOCATION WITH BOTTOM MOUNT SPRING TENSIONER IS UP 2.00 (51).
  - 10) THERE WILL BE APPROXIMATELY 1.0" GAP BETWEEN BLADE TIP AND BELT FOR UNTENSIONED SPRING.
  - 11) THE FIRST -XX IN SUFFIX INDICATES BELT WIDTH. THE NEXT X INDICATES BLADE TYPE:
    - 0 = NO BLADES
    - A = INLINE TC BLADE
    - C = INLINE TC INSERT W/SS HOLDER BLADE
    - R = TC INSERT W/SS HOLDER REVERSING BLADE
    - T = TUNGSTEN CARBIDE REVERSING BLADE
    - S = STAINLESS STEEL REVERSING BLADE
    - U = URETHANE REVERSING BLADE
  - THE NEXT XX INDICATES BLADE COVERAGE.
    - 00 = NO BLADES
  - THE NEXT XX INDICATES BLADE COLOR:
    - 00 = NO BLADES
    - BR = BROWN
    - GR = GREEN
    - OR = ORANGE
  - THE NEXT X INDICATES MAINFRAME TYPE:
    - P = STANDARD DUTY
    - S = 316 STAINLESS STEEL
  - THE LAST X INDICATES ACCESSORY OPTIONS:
    - 0 = NO TENSIONER
    - A = INLINE/REV AIR TENSIONER
    - S = INLINE/REV SPRING TENSIONER

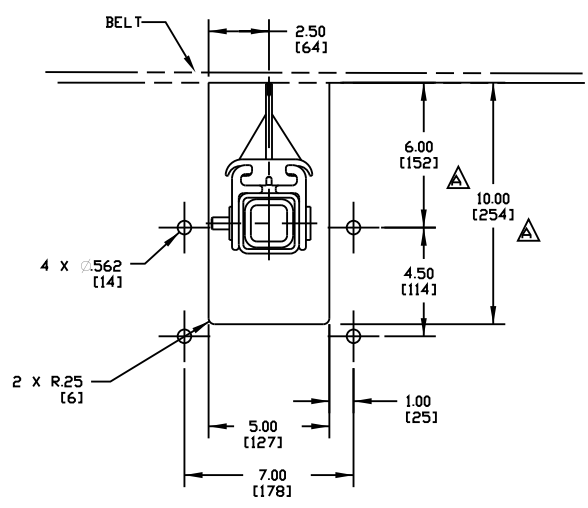

CHUTE CUTOUT DETAIL  
CLEANER SHOWN IN WORKING POSITION

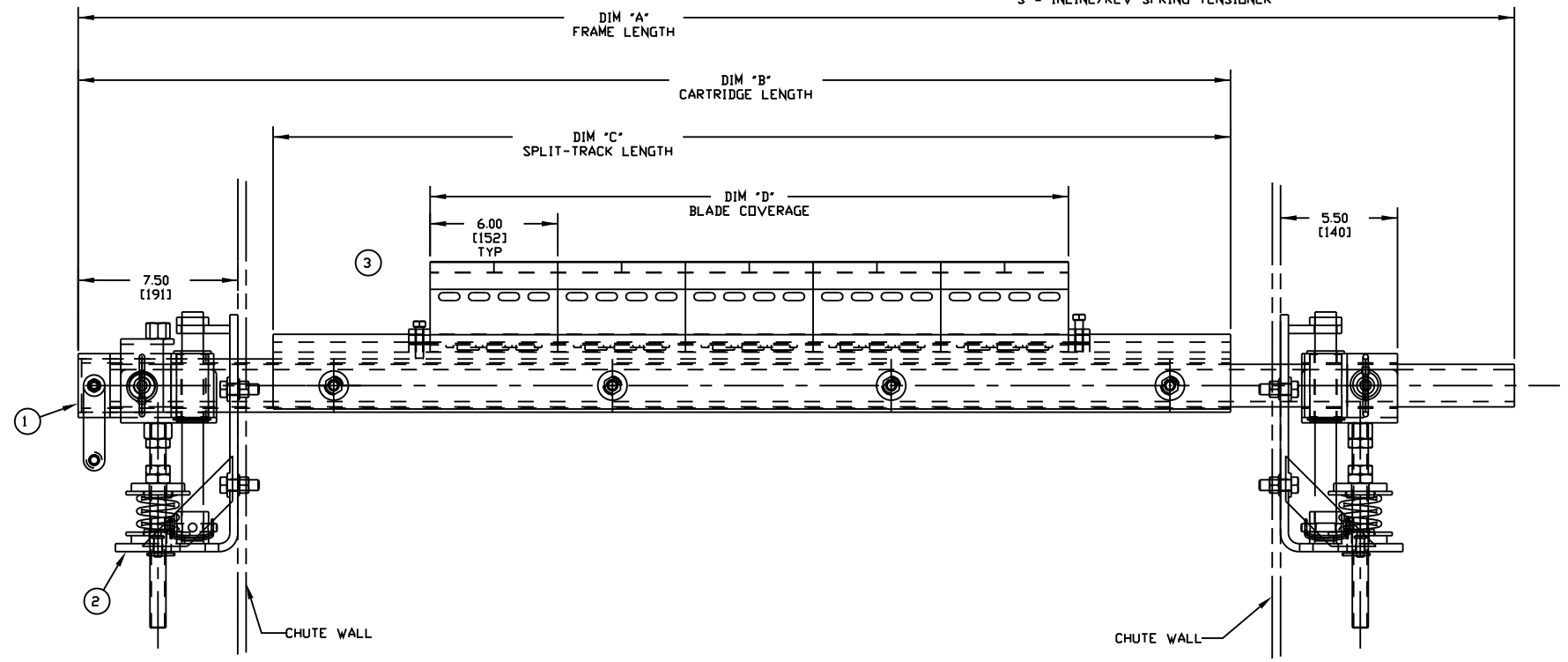
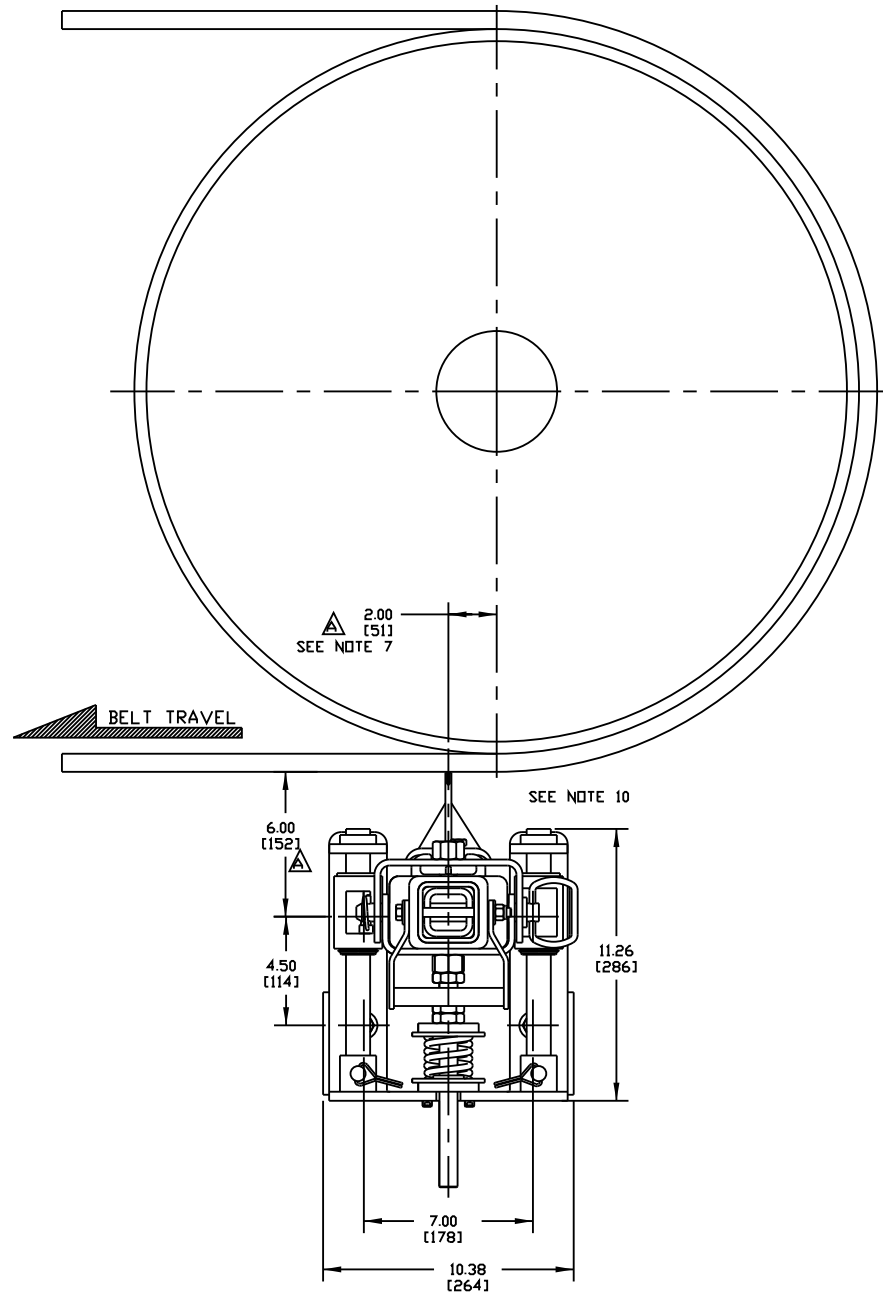

©Copyright 2015 Martin Engineering. All rights reserved. Covered by U.S. and Foreign patents pending and issued. R and TM indicate trademarks of Martin Engineering.

F	DN P/N DT2S120X114XXXX CHG DIM "C" FROM 12300 TO 12900	14176	03/26/15	RND
E	ADDED OPTION "C" & "R" TO BLADE TYPE IN THE NOTES (PRIE0332)	----	05/02/11	MJB
D	RNVD "NUMBER OF TURNS" FROM THE TENSIONING CHART	12348	07/10/08	MJB
C	UPDATED THE TENSIONING CHART	11983	04/12/07	MJB
B	CHG NOTE	11503	11/16/05	MJB
A	ADD TENS CHART/ADD NOTE/CHG DIM FROM 5.00, 9.00, 4.00 TO 6.00 (2), 10.00, 2.00/CHG DRAWING FROM -R TO -RS	----	03/16/05	MJB

MARTIN ENGINEERING-USA NEPONSET, IL USA		DATE	07/20/04
TITLE MARTIN® DT2S SEC ASM W/REV BLADES & INLINE/REV SPRING TENS		CHECKED	
SALES DRAWING		DATE	09/28/04
M0613		APPROVED	JMM
S50017-RS		DATE	09/28/04
SCALE		SCALE	1/4

