

PART NUMBER	P/N ITEM 3	P/N ITEM 4	DIM 'A'	DIM 'B'	DIM 'C'	WEIGHT
CTRS20	CTRS20A900	CTRS20A902	939.0 [36.97]	736.0 [28.98]	545.0 [21.46]	39.2
CTRS24	CTRS24A900	CTRS24A902	1038.0 [40.87]	838.0 [32.99]	644.0 [25.35]	43.0
CTRS30	CTRS30A900	CTRS30A902	1190.0 [46.85]	990.0 [38.98]	792.0 [31.18]	49.0
CTRS36	CTRS36A900	CTRS36A902	1344.0 [52.91]	1144.0 [45.04]	941.0 [37.05]	55.0
CTRS42	CTRS42A900	CTRS42A902	1496.0 [58.90]	1296.0 [51.02]	1089.0 [42.87]	60.8
CTRS48	CTRS48A900	CTRS48A902	1648.0 [64.88]	1448.0 [57.01]	1238.0 [48.74]	66.7
CTRS54	CTRS54A900	CTRS54A902	1800.0 [70.87]	1600.0 [62.99]	1436.0 [56.54]	74.2
CTRS60	CTRS60A900	CTRS60A902	1952.0 [76.85]	1752.0 [68.98]	1584.0 [62.36]	80.2
CTRS72	CTRS72A900	CTRS72A902	2257.0 [88.86]	2057.0 [80.98]	1881.0 [74.06]	92.1

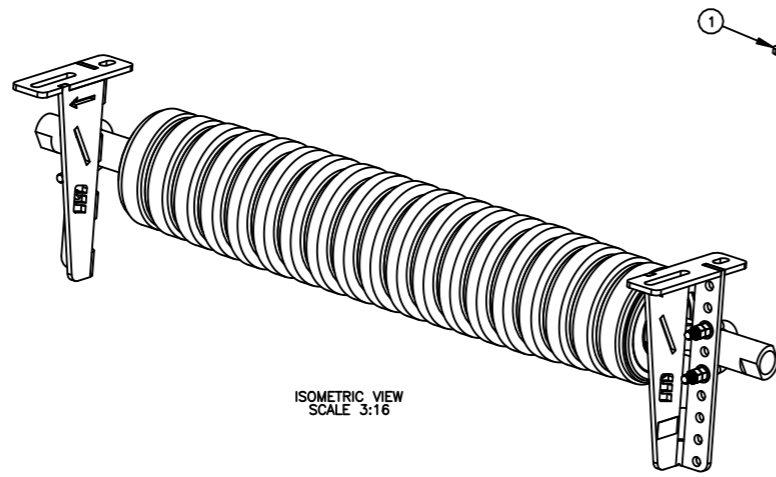

ISOMETRIC VIEW  
SCALE 3:16

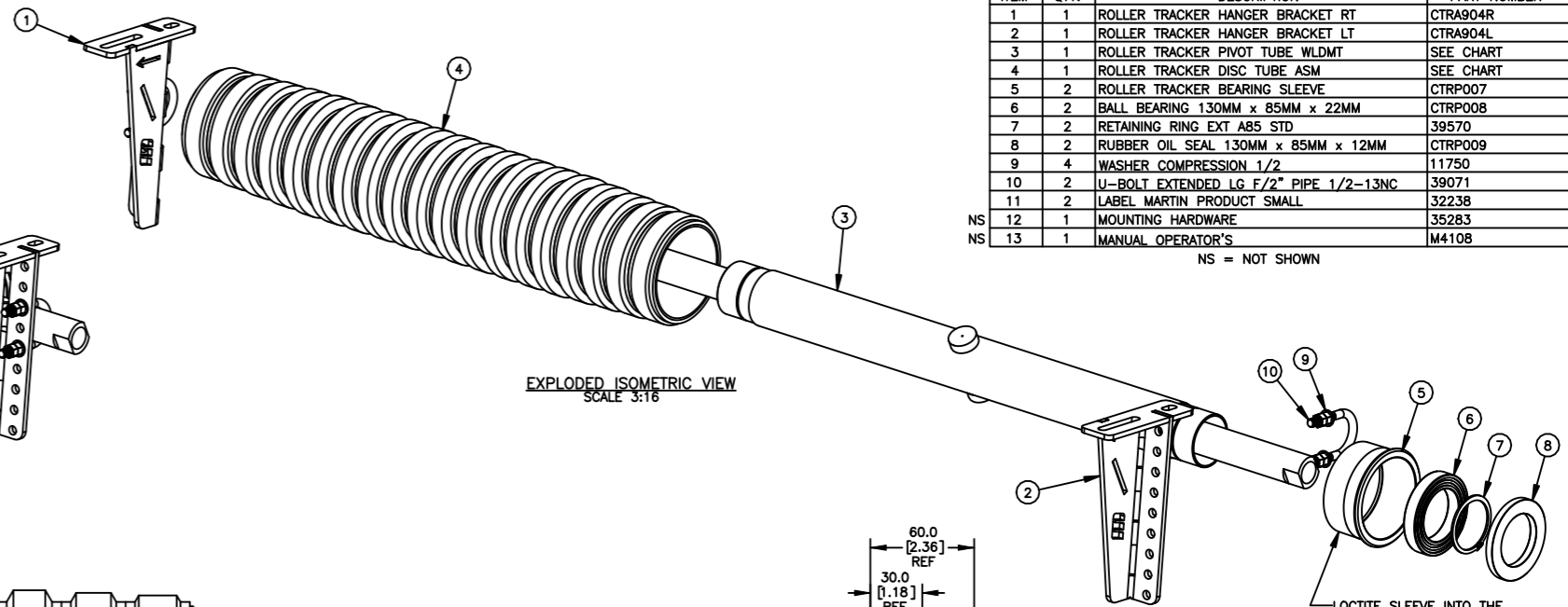

EXPLODED ISOMETRIC VIEW  
SCALE 3:16

ITEM	QTY.	DESCRIPTION	PART NUMBER
1	1	ROLLER TRACKER HANGER BRACKET RT	CTRA904R
2	1	ROLLER TRACKER HANGER BRACKET LT	CTRA904L
3	1	ROLLER TRACKER PIVOT TUBE W/DMT	SEE CHART
4	1	ROLLER TRACKER DISC TUBE ASM	SEE CHART
5	2	ROLLER TRACKER BEARING SLEEVE	CTRPO07
6	2	BALL BEARING 130MM x 85MM x 22MM	CTRPO08
7	2	RETAINING RING EXT AB5 STD	39570
8	2	RUBBER OIL SEAL 130MM x 85MM x 12MM	CTRPO09
9	4	WASHER COMPRESSION 1/2	11750
10	2	U-BOLT EXTENDED LG F/2" PIPE 1/2-13NC	39071
11	2	LABEL MARTIN PRODUCT SMALL	32238
12	1	MOUNTING HARDWARE	35283
NS	13	MANUAL OPERATOR'S	M4108

NS = NOT SHOWN

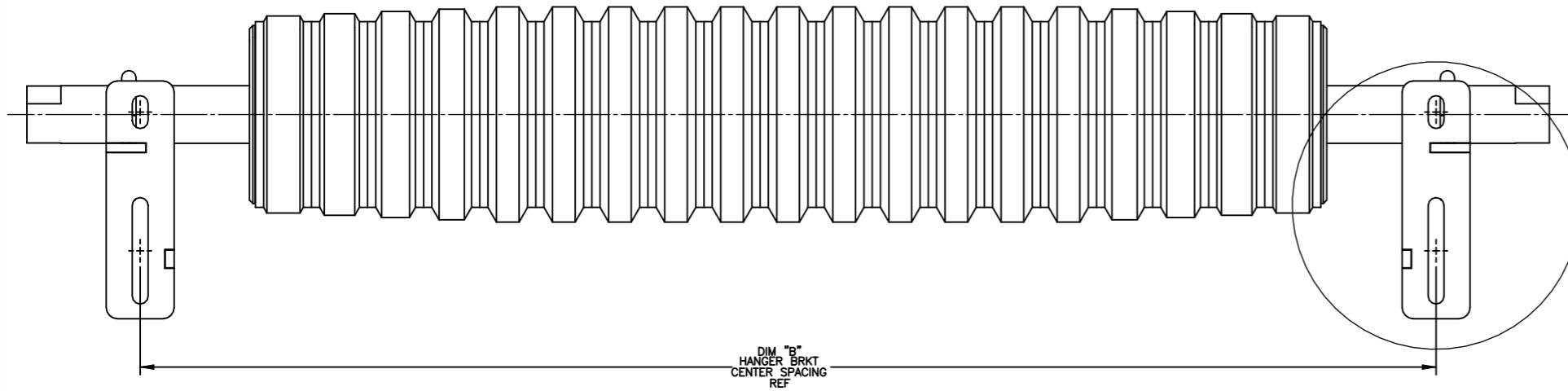

DIM "B"  
HANGER BRKT  
CENTER SPACING  
REF

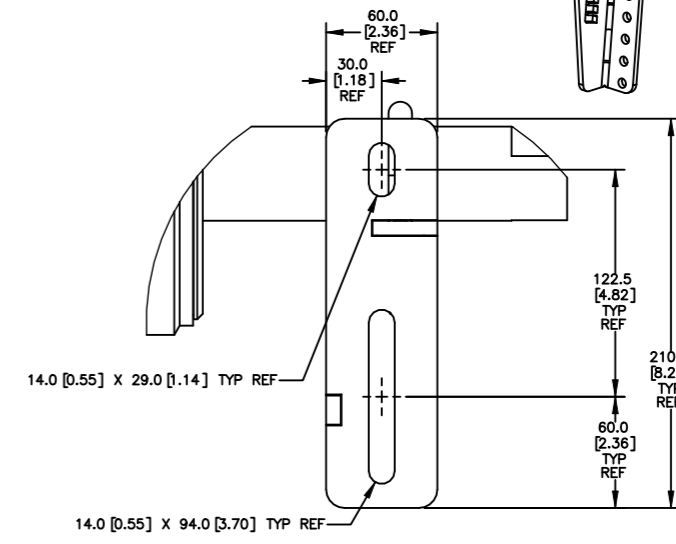

DETAIL A  
SCALE 1:2

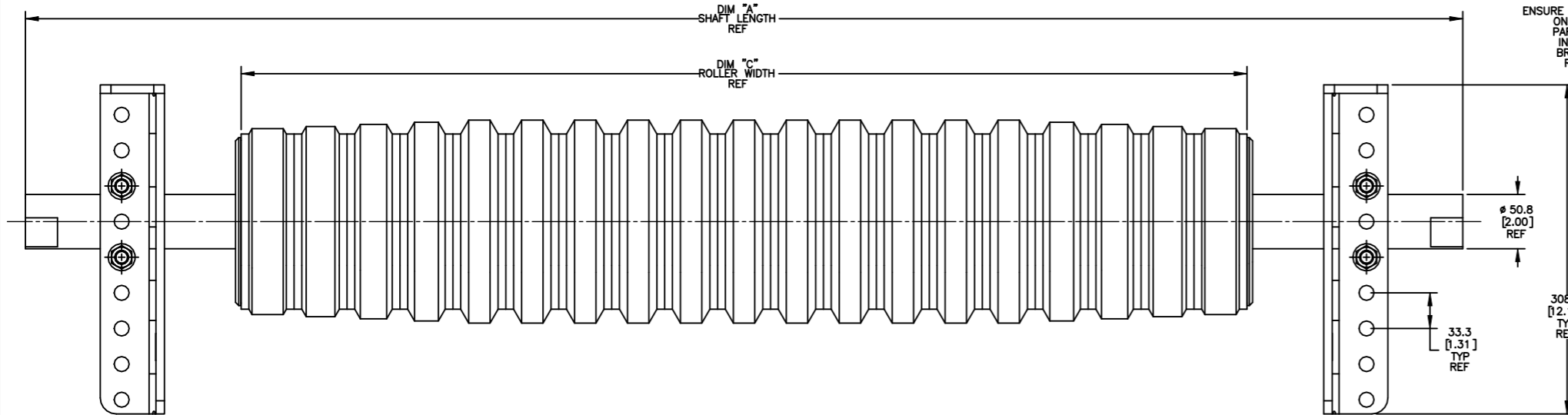

ENSURE THAT THE FLATS ON THE SHAFT ARE PARALLEL WITH THE INDICATOR ON THE BRACKET FOR NON REVERSING BELTS

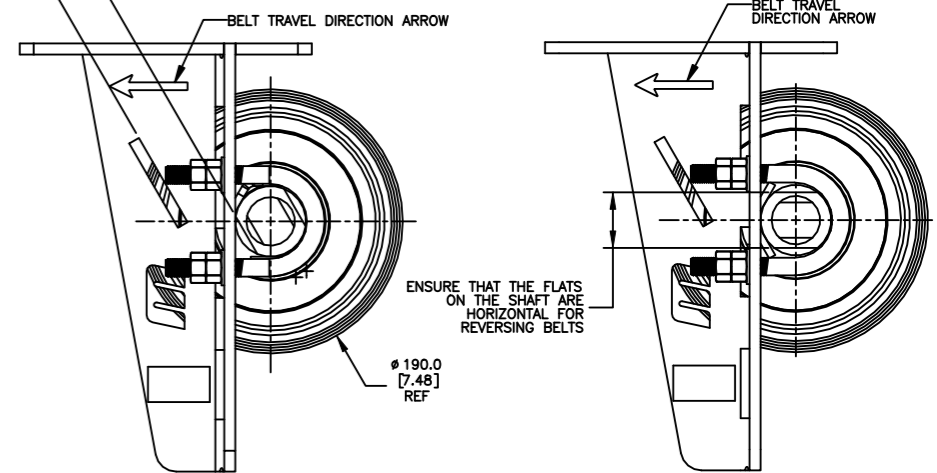

© Copyright 2018 Martin Engineering. All rights reserved. Covered by U.S. and foreign patents pending and issued. ® and ™ indicate trademarks of Martin Engineering.

	MARTIN ENGINEERING NEPONSET, IL USA	DRAWN RND DATE 05/25/18
		CHECKED

A	ADDED & ROUTED P/N CTR572 (PR13932)	12/19/19	RND
REV	DESCRIPTION	ECN	DATE BY
MATERIAL:	FINISH:-	WEIGHT:	
UNLESS OTHERWISE SPECIFIED TOLERANCES IN MM [INCH]:		SURFACE FINISH: ✓	
DIMENSIONS ARE IN MM [INCH]		ANGULAR: ±-	
[INCH] ARE FOR REFERENCE ONLY .XX = ±.75 [.03]		DRAFT ANGLE: -	
SOLIDWORKS			

TITLE	MARTIN ROLLER TRACKER ASSEMBLY	ENG. <i>sdp</i> DATE 06/06/18
DRAWING NUMBER	CTRSXX	I.E. <i>WJS</i> DATE 06/25/18
APPROVED		APPROVED <i>PRB</i> DATE 06/26/18
		SCALE 3:8