

PART NUMBER (2ND, 3RD, AND 4TH X)	BELT WIDTH [IN]
C1CSXR18XXX	18
C1CSXR24XXX	24
C1CSXR30XXX	30
C1CSXR36XXX	36
C1CSXR42XXX	42

PART NUMBER (2ND, 3RD, AND 4TH X)	BELT WIDTH [MM]
C1CSXR040XXX	400
C1CSXR045XXX	450
C1CSXR050XXX	500
C1CSXR075XXX	750
C1CSXR080XXX	800
C1CSXR090XXX	900
C1CSXR100XXX	1000
C1CSXR105XXX	1050

(PART NUMBER FIRST X) TENSIONER/INSTALLATION KIT REQUIREMENTS AND MATERIAL		
PART NUMBER	TENSIONER/INSTALLATION KIT MATERIAL	P/N INSTALLATION KIT
C1CSBRXXXXXX	NO TENSIONER/BLADE ONLY	-----
C1CSIRXXXXXX	TENSIONER WITH FIXED POINT MNT BRKT STL	C1CT1ST
C1CSSRXXXXXX	TENSIONER WITH FIXED POINT MNT BRKT SS	C1CT1SS

(PART NUMBER 5TH X) BLADE CARBIDE TYPE	
PART NUMBER	APPLICATION
C1CSRXXXAXX	STANDARD/MODERATE VERSION, SUITABLE FOR ABRASIVE MATERIALS AND LOW/MEDIUM BELT SPEEDS, ALLOWED FOR MECHANICAL SPLICES, HAS CHEMICAL RESISTANCE
C1CSRXXXBXX	SEVERE VERSION, SUITABLE FOR HIGHLY ABRASIVE MATERIALS AND HIGH BELT SPEEDS, ALLOWED FOR MECHANICAL SPLICES
C1CSRXXXQXX	EXTREME VERSION, SUITABLE FOR EXTREMELY ABRASIVE MATERIALS AND HIGHEST BELT SPEEDS, NOT ALLOWED FOR MECHANICAL SPLICES

ITEM	QTY.	DESCRIPTION	PART NUMBER
1	1	MARTIN CLEANSRAPE CLEANER ASSEMBLY	SEE CHARTS

NOTES:
 1) IN THE C1C PART NUMBER:
 THE S INDICATES A SMALL CLEANSRAPE BLADE/SYSTEM ASSEMBLY.
 THE FIRST X INDICATES THE ASSEMBLY TYPE:
 B = BLADE ASSEMBLY, NO TENSIONER
 T = BLADE ASSEMBLY, TENSIONER STANDARD PAINTED STEEL
 S = BLADE ASSEMBLY, TENSIONER STAINLESS STEEL
 THE R INDICATES RUBBER BLADE BODY MATERIAL.
 THE NEXT XXX INDICATES THE BELT WIDTH:
 SXX = INCH BELT WIDTH
 XXX = MM BELT WIDTH / 10
 THE NEXT X INDICATES BLADE CARBIDE TYPE:
 A = A CARBIDE GRADE
 B = B CARBIDE GRADE
 C = C CARBIDE GRADE
 THE LAST XX INDICATES NUMBER OF ELEMENTS IN THE BLADE.

- INSTALLATION NOTES:
- 1) BLADE CARBIDE SCRAPERS ARE MOLDED INTO THE RUBBER BODY AT AN ANGLE CREATING A SERRATED CLEANING EDGE. CLEANER MUST BE MOUNTED AT AN ANGLE AS SHOWN. THE IDEAL INSTALLATION ANGLE IS BETWEEN 17° AND 19°. ANGLES FROM 15° TO 21° ARE ACCEPTABLE BUT TENSIONER TENSION NEEDS TO BE ADJUSTED AS THE ANGLE CHANGES FROM THE IDEAL ANGLE. CLEANER MUST NOT LIE IN THE MATERIAL PATH. BELT WIDTH MUST NOT EXCEED A RATIO OF 3:1 TO THE HEAD PULLEY DIAMETER. HEAD PULLEY RANGE IS 305 [12.00] MIN. TO 508 [20.00] MAX.
 - 2) CHUTE WALLS MUST BE STRONG ENOUGH TO NOT FLEX WHEN THE CLEANER IS TENSIONED. ADDITIONAL CHUTE WALL STRUCTURE MAY BE REQUIRED TO PREVENT CHUTE WALL FROM FLEXING.
 - 3) LOCATE AND INSTALL THE FIXED POINT MOUNT BRACKET ON THE INSIDE OF THE FAR SIDE CHUTE WALL. MEASURE THE HEAD PULLEY RADIUS PLUS THE LAGGING, BELT THICKNESS, AND ADD THE 9.6 [1.38]. THIS IS THE RADIUS ARC THAT THE FIXED POINT BRACKET WILL BE LOCATED ON. LOCATE THE FIXED POINT BRACKET LOWER MOUNTING HOLE ON THE VERTICAL CENTERLINE OF THE HEAD PULLEY (AT THE 6:00 O'CLOCK POSITION). THIS POINT MAY BE ADJUSTED (ROTATED) TO ENSURE IT DOES NOT GO PAST THE BELT EXIT POINT ON THE HEAD PULLEY. MARK THE HOLE LOCATIONS FROM THE FIXED POINT BRACKET AND DRILL THE MOUNTING HOLES (IF NOT WELDING IN PLACE). BOLT OR WELD THE FIXED POINT BRACKET TO THE INSIDE OF THE CHUTE WALL.
 - 4) ON THE INSIDE OF THE OPERATORS SIDE OF THE CHUTE WALL MARK THE LOCATION OF THE TENSIONER MOUNT PLATE. LOCATE THE TOP CORNERS ON A 28.7 [1.13] RADIUS ARC PAST THE BELT EDGE AND THE UPPER CORNER ON THE HORIZONTAL CENTERLINE (AT THE 3:00 O'CLOCK POSITION). BOLT OR WELD THE TENSIONER MOUNT BRACKET TO THE INSIDE OF THE CHUTE WALL. THE TENSIONER MOUNT PLATE MAY BE ADJUSTED (ROTATED) AS REQUIRED TO KEEP THE CLEANER BELOW THE PRODUCT DISCHARGE POINT AND AT THE SPECIFIED INSTALLATION ANGLE. THE TOP OF THE CLEANER SHOULD NOT BE ABOVE THE 2:00 O'CLOCK POSITION. SEE THE CUTOUT DETAIL. BOLT THE TENSIONER TO THE TENSIONER MOUNT BRACKET. LEAVE THE ADJUSTMENT BOLTS LOOSE AT THIS TIME.
 - 5) MEASURE THE APPROXIMATE CABLE LENGTH AND ASSEMBLE THE CABLE THIMBLES AND CLAMPS TO THE TENSIONER END OF THE BLADE ASSEMBLY. INSTALL THE CLEANER TO THE FIXED POINT BRACKET. LEAVE THE ADJUSTMENT BOLTS LOOSE AT THIS TIME. HOLD THE CLEANER TO THE HEAD PULLEY AND HOOK ONTO THE TENSIONER. MAKE SURE THE TENSIONER ADJUSTMENT NUTS ARE AT THE END OF THE TENSIONER THREADED ROD. TIGHTEN THE TENSIONER ADJUSTMENT NUTS UNTIL THE CLEANER IS HELD FIRMLY AGAINST THE HEAD PULLEY. ADJUST THE FIXED POINT BRACKET AND TENSIONER BRACKET SO THE OUTER TWO ELEMENTS ON EACH SIDE OF THE CLEANER ARE APPROXIMATELY 3.3 [1.13] AWAY FROM THE BELT. INCREASE THE RELIEF AS NECESSARY TO ENSURE MECHANICAL SPLICES WILL PASS. TIGHTEN ALL BOLTS.
 - 6) TENSION THE CLEANER PER THE RECOMMENDED TENSION IN THE MANUAL. THE LENGTH OF THE CHAIN OR CABLE MUST NOT EXCEED 125 [5.00] ON EITHER SIDE OF THE CLEANER. EXCESS CHAIN OR CABLE COULD RESULT IN VIBRATION THAT COULD DAMAGE THE BELT OR THE CLEANER.

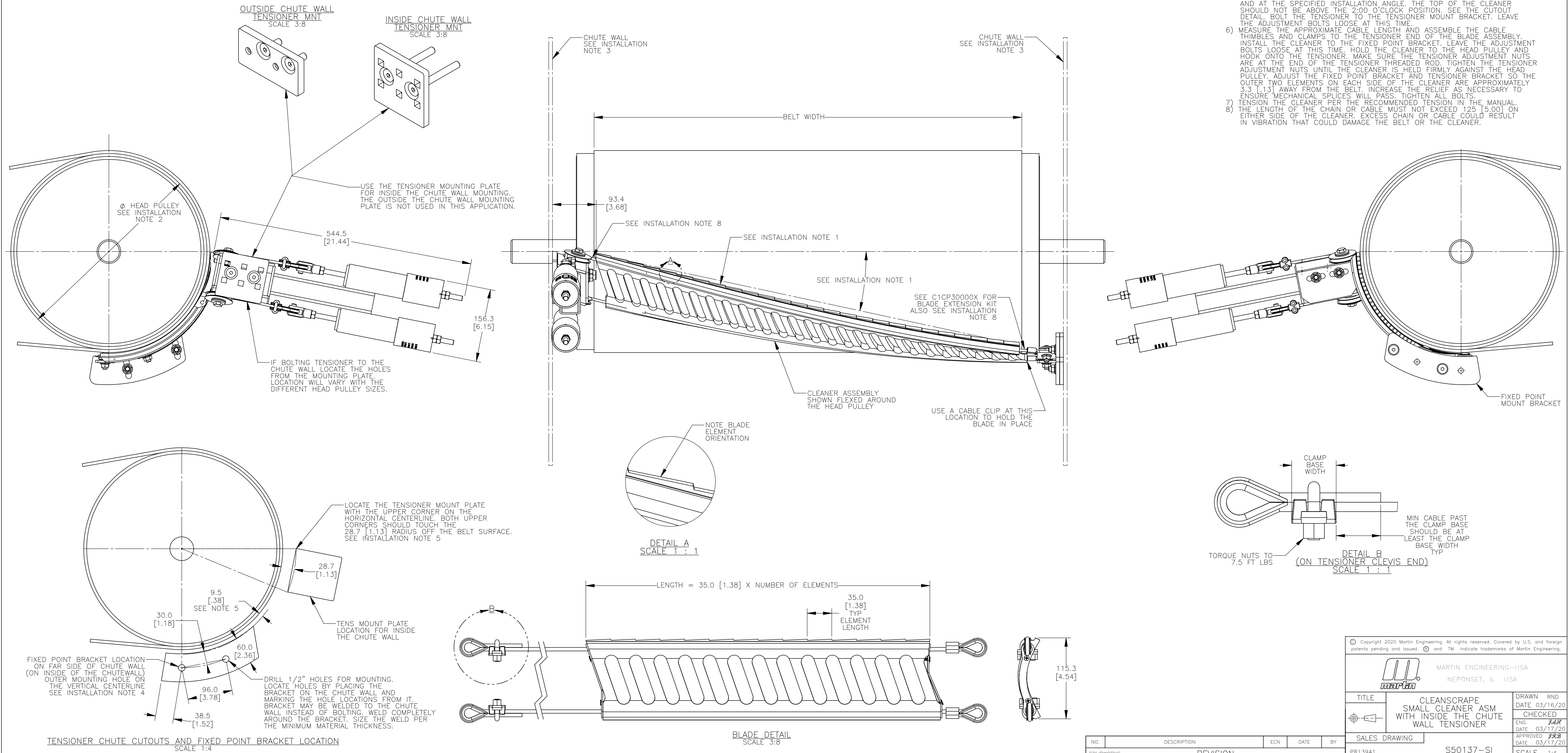

Copyright 2020 Martin Engineering. All rights reserved. Covered by U.S. and foreign patents pending and issued. ® and TM indicate trademarks of Martin Engineering.

MARTIN ENGINEERING—USA
NEPONSET, IL USA

MARTIN ENGINEERING

TITLE	CLEANSRAPE SMALL CLEANER ASM WITH INSIDE THE CHUTE WALL TENSIONER	DRAWN RND	DATE 03/16/20
ENG.	FAA	CHECKED	DATE 03/17/20
APPROVED	FAA	DATE	03/17/20
SCALE	1:4		

NO.	DESCRIPTION	ECN	DATE	BY
SOLIDWORKS	REVISION			

SALES DRAWING PR13941 S50137-SI