

PART NUMBER	BELT WIDTH	DIMENSION "A" BLADE COVERAGE	DIMENSION "B" STD FRAME LG	DIMENSION "B" EXT FRAME LG	PART NUMBER ITEM 2
C1QCP3S18S8XXXX	457.2 [18.00]	254.0 [10.00]	863.6 [34.00]	1270.0 [50.00]	38850
C1QCP3S18S6XXXX	457.2 [18.00]	304.8 [12.00]	863.6 [34.00]	1270.0 [50.00]	38850
C1QCP3S18S4XXXX	457.2 [18.00]	355.6 [14.00]	863.6 [34.00]	1270.0 [50.00]	38850
C1QCP3S24S8XXXX	609.6 [24.00]	406.4 [16.00]	1168.4 [46.00]	1422.4 [56.00]	38850
C1QCP3S24S6XXXX	609.6 [24.00]	457.2 [18.00]	1168.4 [46.00]	1422.4 [56.00]	38850
C1QCP3S24S4XXXX	609.6 [24.00]	508.0 [20.00]	1168.4 [46.00]	1422.4 [56.00]	38850
C1QCP3S30S8XXXX	762.0 [30.00]	558.8 [22.00]	1320.8 [52.00]	1574.8 [62.00]	38850
C1QCP3S30S6XXXX	762.0 [30.00]	609.6 [24.00]	1320.8 [52.00]	1574.8 [62.00]	38850
C1QCP3S30S4XXXX	762.0 [30.00]	660.4 [26.00]	1320.8 [52.00]	1574.8 [62.00]	38850
C1QCP3S36S8XXXX	914.4 [36.00]	711.2 [28.00]	1524.0 [60.00]	2133.6 [84.00]	38850
C1QCP3S36S6XXXX	914.4 [36.00]	762.0 [30.00]	1524.0 [60.00]	2133.6 [84.00]	38850
C1QCP3S36S4XXXX	914.4 [36.00]	812.8 [32.00]	1524.0 [60.00]	2133.6 [84.00]	38850
C1QCP3S42S8XXXX	1066.8 [42.00]	863.6 [34.00]	1828.8 [72.00]	2286.0 [90.00]	38850
C1QCP3S42S6XXXX	1066.8 [42.00]	914.4 [36.00]	1828.8 [72.00]	2286.0 [90.00]	38850
C1QCP3S42S4XXXX	1066.8 [42.00]	965.2 [38.00]	1828.8 [72.00]	2286.0 [90.00]	38850
C1QCP3S48S8XXXX	1219.2 [48.00]	1016.0 [40.00]	1981.2 [78.00]	2438.4 [96.00]	38850
C1QCP3S48S6XXXX	1219.2 [48.00]	1066.8 [42.00]	1981.2 [78.00]	2438.4 [96.00]	38850
C1QCP3S48S4XXXX	1219.2 [48.00]	1117.6 [44.00]	1981.2 [78.00]	2438.4 [96.00]	38850
C1QCP3S54S8XXXX	1371.6 [54.00]	1168.4 [46.00]	2133.6 [84.00]	2590.8 [102.00]	38850-2
C1QCP3S54S6XXXX	1371.6 [54.00]	1219.2 [48.00]	2133.6 [84.00]	2590.8 [102.00]	38850-2
C1QCP3S54S4XXXX	1371.6 [54.00]	1270.0 [50.00]	2133.6 [84.00]	2590.8 [102.00]	38850-2
C1QCP3S60S8XXXX	1524.0 [60.00]	1320.8 [52.00]	2286.0 [90.00]	2743.2 [108.00]	38850-2
C1QCP3S60S6XXXX	1524.0 [60.00]	1371.6 [54.00]	2286.0 [90.00]	2743.2 [108.00]	38850-2
C1QCP3S60S4XXXX	1524.0 [60.00]	1422.4 [56.00]	2286.0 [90.00]	2743.2 [108.00]	38850-2
C1QCP3S66S8XXXX	1676.4 [66.00]	1473.2 [58.00]	2438.4 [96.00]	2895.6 [114.00]	38850-2
C1QCP3S66S6XXXX	1676.4 [66.00]	1524.0 [60.00]	2438.4 [96.00]	2895.6 [114.00]	38850-2
C1QCP3S66S4XXXX	1676.4 [66.00]	1574.8 [62.00]	2438.4 [96.00]	2895.6 [114.00]	38850-2
C1QCP3S72S8XXXX	1828.8 [72.00]	1625.6 [64.00]	2590.8 [102.00]	3048.0 [120.00]	38850-2
C1QCP3S72S6XXXX	1828.8 [72.00]	1676.4 [66.00]	2590.8 [102.00]	3048.0 [120.00]	38850-2
C1QCP3S72S4XXXX	1828.8 [72.00]	1727.2 [68.00]	2590.8 [102.00]	3048.0 [120.00]	38850-2

NOTES:
1) ALL DIMENSIONS ARE GIVEN IN MILLIMETERS [INCHES] AND ARE FOR REFERENCE ONLY.
2) IN THE C1QCP3 PART NUMBER THE FIRST SXX INDICATES THE BELT WIDTH IN STANDARD INCH UNITS FOR BELT WIDTHS 18 THRU 72.
S18 = 18 BELT WIDTH
S72 = 72 BELT WIDTH
THE NEXT SX INDICATES THE LESS BELT WIDTH BLADE COVERAGE IN STANDARD INCH UNITS.
00 = NO BLADE
S4 = 4 LESS BELT WIDTH
S6 = 6 LESS BELT WIDTH
S8 = 8 LESS BELT WIDTH
THE FOURTH X IN THE PART NUMBER INDICATES THE BLADE COLOR:
0 = NO BLADE
B = BROWN
T = TAN
G = GREEN
N = NAVY BLUE
O = ORANGE
THE FIFTH X INDICATES IF THE BLADE IS SOLID OR SEGMENTED:
0 = SEGMENTED BLADE / NO BLADE
1 = SOLID BLADE
THE SIXTH X IN THE PART NUMBER INDICATES THE MAINFRAME MATERIAL/FINISH:
P = STANDARD PAINTED STEEL MAINFRAME
E = STANDARD PAINTED STEEL MAINFRAME WITH EXTENDED TORQUE TUBES
F = STANDARD STAINLESS STEEL MAINFRAME
Z = STANDARD STAINLESS STEEL MAINFRAME WITH EXTENDED SS TORQUE TUBES
T = STANDARD PAINTED STEEL MAINFRAME
THE LAST X INDICATES THE TENSIONER OPTIONS:
BLANK = NO TENSIONER
T = SINGLE TWIST TENSIONER (38850) FOR BELT WIDTHS 18 TO 48.
DUAL TWIST TENSIONER (38850-2) FOR BELT WIDTHS 54 AND ABOVE.

NOTES:
3) WHERE EXTREME OR UNUSUAL CONDITIONS EXIST, OR SPECIAL MAINFRAME LENGTHS ARE REQUIRED CONTACT MARTIN ENGINEERING. FOR SEVERE APPLICATIONS WELD MAINFRAME ADAPTER DIRECTLY TO MAINFRAME.
4) INSIDE CHUTE WALL WIDTH MUST BE A MINIMUM OF BELT WIDTH PLUS 127.0 [5.00] IN ORDER FOR CLEANER TO BE INSTALLED WITH TENSIONERS BOLTED DIRECTLY TO CHUTE WALL.
5) REFER TO OPERATOR'S MANUALS M3837 AND M4126 FOR INSTALLATION INSTRUCTIONS.
6) CLEANER CAN BE LOCATED ANYWHERE ALONG THE ARC, AS LONG AS THE MAINFRAME IS OUT OF MATERIAL TRAJECTORY AND THE BLADE TIPS ARE BELOW THE HORIZONTAL CENTERLINE OF THE HEAD PULLEY.
7) THE QC1+ PV PRE-CLEANER BLADE IS DESIGNED TO REMOVE THE INITIAL CARRYBACK ONLY. DO NOT OVER TENSION.
8) THE QC1+ PV PRE-CLEANER BLADE IS DESIGNED FOR HEAD PULLEYS WITH A DIAMETER OF 304.8 [12.00] TO 406.4 [16.00].
9) BLADE COVERAGE IS LESS THAN BELT WIDTH, DUE TO POSSIBLE MISTRACKING OR DAMAGED EDGES OF THE BELT.

ITEM	QTY.	DESCRIPTION	PART NUMBER
1	1	MARTIN QC1+ PV BLADE MAINFRAME ASM	C1QCP3SXXSXXXX
2	1	MARTIN TWIST TENSIONER ASM	SEE CHART
3	1	MARTIN LOW PROFILE STL DOOR 9X12	CYA-0912

ASSEMBLY PART NO.	COLOR
C1QCP3SXXSXXXX	BROWN
C1QCP3SXXSXTXXX	TAN
C1QCP3SXXSXGXXX	GREEN
C1QCP3SXXSXNXXX	NAVY BLUE
C1QCP3SXXSXOXXX	ORANGE

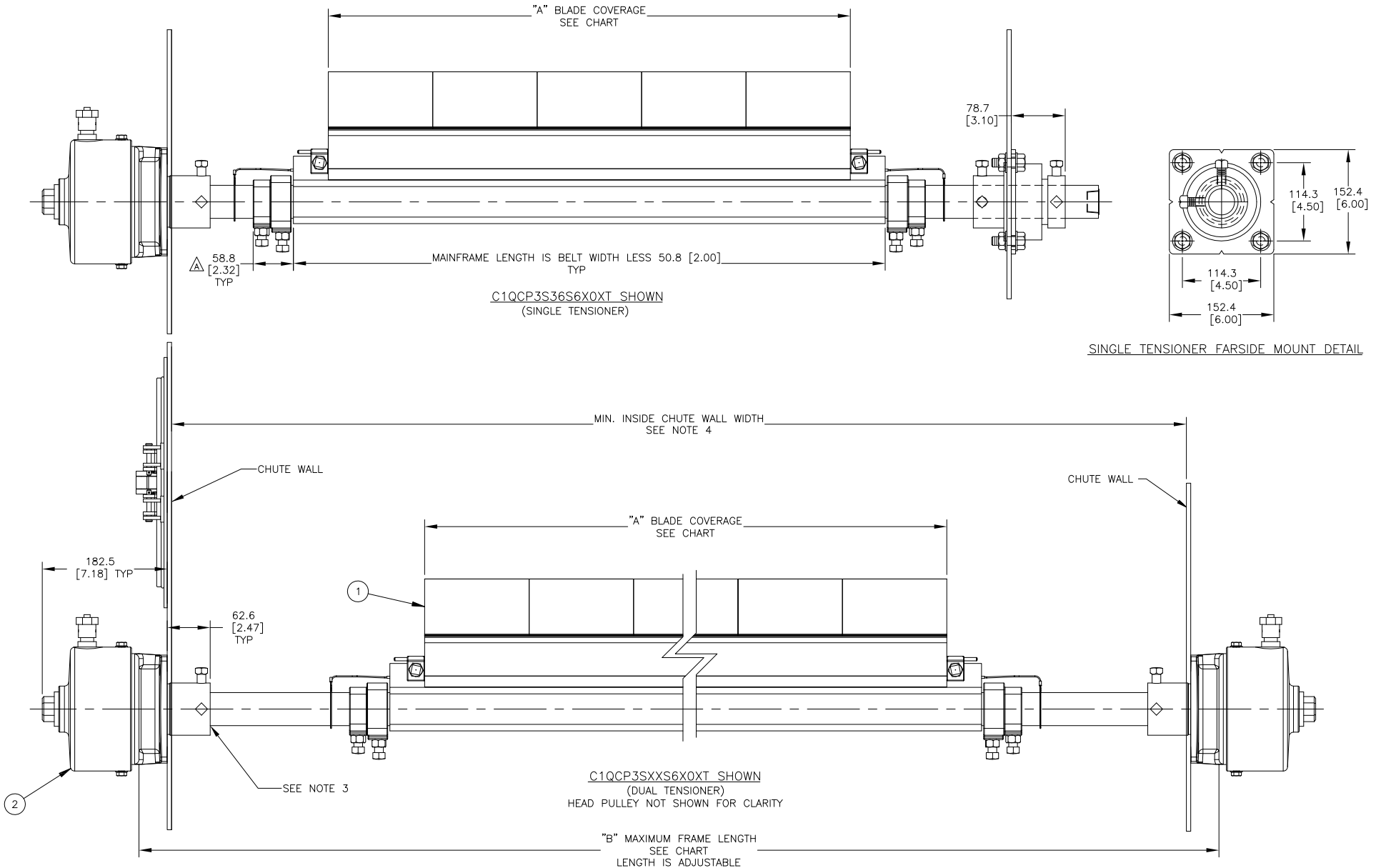
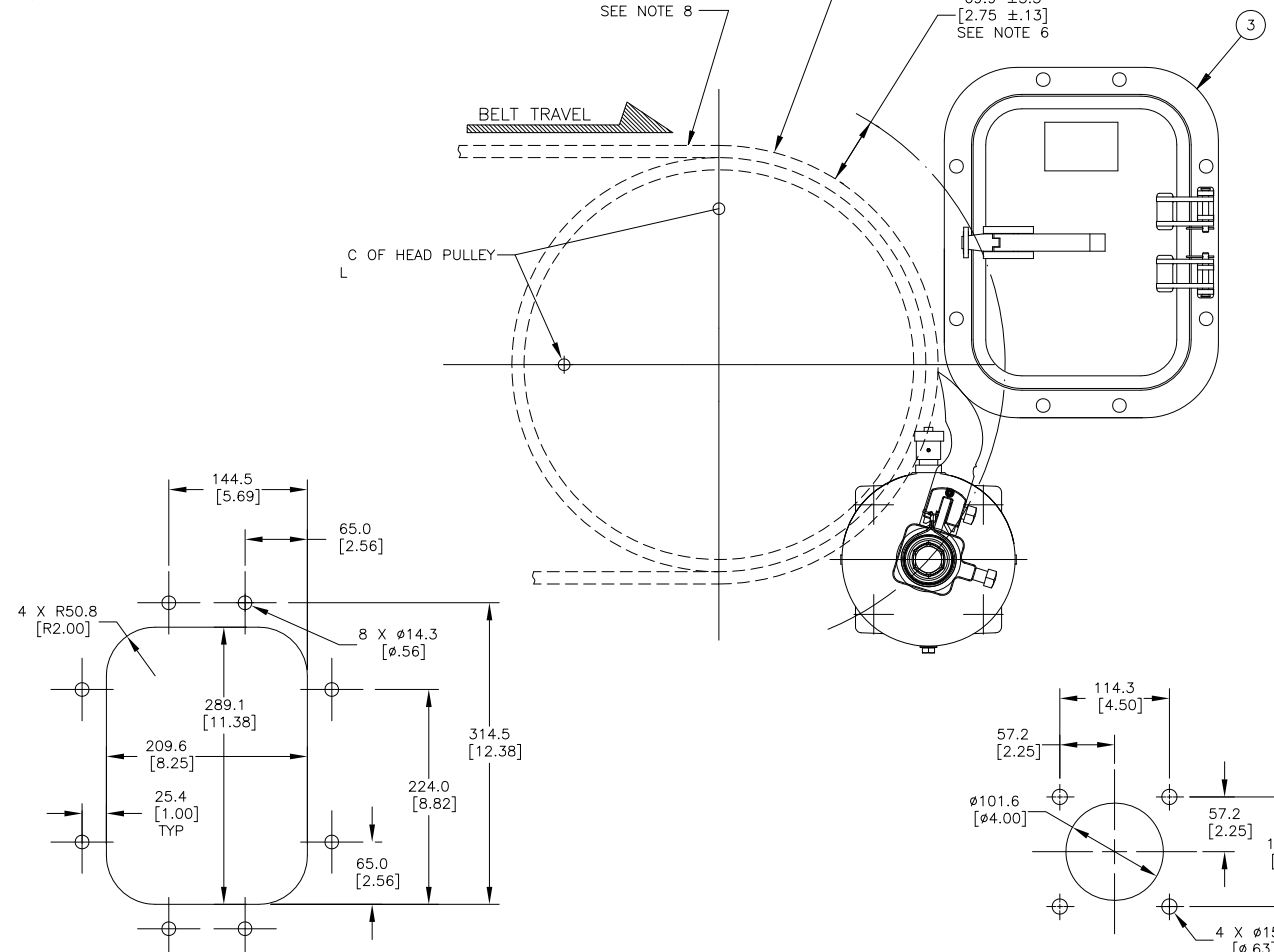
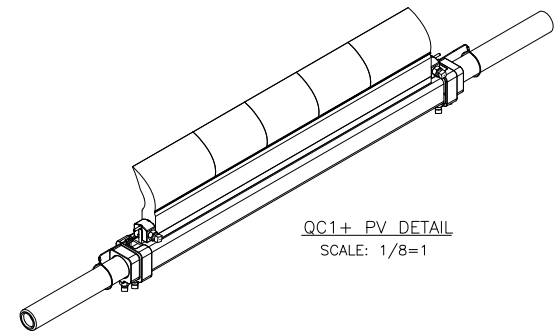

© Copyright 2019 Martin Engineering. All rights reserved. Covered by U.S. and foreign patents pending and issued. ® and TM indicate trademarks of Martin Engineering.

MARTIN ENGINEERING
NEPONSET, IL USA

TITLE: MARTIN QC1+ PV 3-PC ASM WITH TWIST TENS ASM & STEEL DOOR
228.6 [9] X 304.8 [12]

DRAWN RND: DATE 06/19/19
CHECKED: 7/19
ENG: DATE 06/26/19
APPROVED: 7/28
DATE 07/08/19
SCALE 1/4

NO.	DESCRIPTION	ECN	DATE	BY
A	CHGD DIM 28.6 TO 58.8 / UPDATED P/N NOTE	15751	10/06/20	JAH

SALES DRAWING: PR13753E S50132-T3