

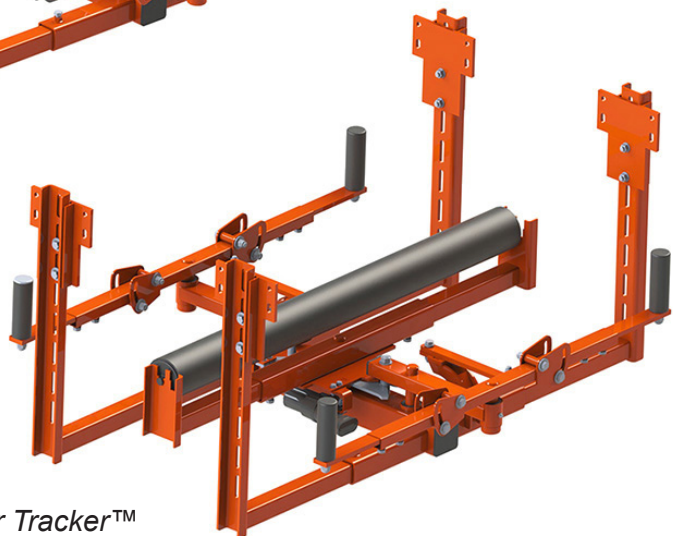

Martin[®] Tracker[™] Reversing



Upper Tracker[™]



Lower Tracker[™]



**Operator's Manual
M4098**

Important

MARTIN ENGINEERING HEREBY DISCLAIMS ANY LIABILITY FOR: DAMAGE DUE TO CONTAMINATION OF THE MATERIAL; USER'S FAILURE TO INSPECT, MAINTAIN AND TAKE REASONABLE CARE OF THE EQUIPMENT; INJURIES OR DAMAGE RESULTING FROM USE OR APPLICATION OF THIS PRODUCT CONTRARY TO INSTRUCTIONS AND SPECIFICATIONS CONTAINED HEREIN. MARTIN ENGINEERING'S LIABILITY SHALL BE LIMITED TO REPAIR OR REPLACEMENT OF EQUIPMENT SHOWN TO BE DEFECTIVE.

Observe all safety rules given herein along with owner and Government standards and regulations. Know and understand lockout/tagout procedures as defined by American National Standards Institute (ANSI) z244.1-1982, *American National Standard for Personnel Protection - Lockout/Tagout of Energy Sources - Minimum Safety Requirements* and Occupational Safety and Health Administration (OSHA) Federal Register, Part IV, 29 CFR Part 1910, *Control of Hazardous Energy Source (Lockout/Tagout); Final Rule*.

The following symbols may be used in this manual:



Danger: Immediate hazards that will result in severe personal injury or death.



Warning: Hazards or unsafe practices that could result in personal injury.



Caution: Hazards or unsafe practices that could result in product or property damages.



Important: Instructions that must be followed to ensure proper installation/operation of equipment.



Note: General statements to assist the reader.

Table of Contents

Section	Page
List of Figures	ii
Introduction	1
General	1
References	1
Safety	1
Materials required	1
Before Installing Belt Tracking System	2
Installing Belt Tracking System	3
Installing lower guide unit	3
Installing upper guide unit	6
Installing air cylinder controls	9
Installing electric actuator controls	11
After Installing Belt Tracking System	12
Part Numbers	15
Appendix. Martin® Tracker™ Reversing Dimensions	A-1

List of Figures

Figure	Title	Page
1	Mounting Dimensions–Martin® Tracker™ Reversing (Lower Unit)	4
2	Mounting Dimensions–Martin® Tracker™ Reversing HD (Lower Unit).	5
3	Mounting Dimensions–Martin® Tracker™ Reversing (Upper Unit)	7
4	Mounting Dimensions–Martin® Tracker™ Reversing HD (Upper Unit).	8
5	Air Cylinder Controls	9
6	Air Cylinder Switching Mechanism Orientation	10
7	Electric Actuator Switching Mechanism Orientation.	11
8	Adjusting Martin® Tracker™ Reversing	22
9	Martin® Tracker™ Reversing (Upper Unit), P/N TKR-XXURSXXX-XXX.	16,17
10	Martin® Tracker™ Reversing HD (Upper Unit), P/N TKR-XXURHXXX-XXX.	19,20
11	Martin® Tracker™ Reversing (Lower Unit), P/N TKR-XXURSXXX-XXX	22-24
12	Martin® Tracker™ Reversing HD (Lower Unit), P/N TKR-XXURHXXX-XXX.	25-27
13	Conveyor Products Warning Label, P/N 23395	29
14	Pinch Point Label, P/N 30528.	29

List of Tables

Table	Title	Page
I	Part Numbers and Quantities for Martin® Tracker™ Reversing Upper Unit	18
II	Dimensions and Weights for Martin® Tracker™ Reversing Upper Unit	18
III	Part Numbers and Quantities for Martin® Tracker™ Reversing HD Upper Unit.	21
IV	Dimensions and Weights for Martin® Tracker™ Reversing HD Upper Unit.	21
V	Part Numbers and Quantities for Martin® Tracker™ Reversing Lower Unit.	24
VI	Dimensions and Weights for Martin® Tracker™ Reversing Lower Unit	24
VII	Part Numbers and Quantities for Martin® Tracker™ Reversing HD Lower Unit	27
VIII	Dimensions and Weights for Martin® Tracker™ Reversing HD Lower Unit.	28

Introduction

General

The Martin® Tracker™ Reversing automatically senses and continuously corrects belt tracking. A light touch of the belt against the guide rollers creates precision correction. The patented tie rod aligner translates the action of the steering bars to the training idlers. The switching mechanism senses the direction of the belt and mechanically engages the proper set of rollers to align reversing belts. The upper guide unit is used on the carrying side of the belt, and the lower guide unit is used on the return side.

References

The following documents are referenced in this manual:

- American National Standards Institute (ANSI) z244.1-1982, *American National Standard for Personnel Protection - Lockout/Tagout of Energy Sources - Minimum Safety Requirements*, American National Standards Institute, Inc., 1430 Broadway, New York, NY 10018.
- Federal Register, Volume 54, Number 169, Part IV, 29 CFR Part 1910, *Control of Hazardous Energy Source (Lockout/Tagout); Final Rule*, Department of Labor, Occupational Safety and Health Administration (OSHA), 32nd Floor, Room 3244, 230 South Dearborn Street, Chicago, IL 60604.

Safety

All safety rules defined in the above documents and all owner/employer safety rules must be strictly followed when working on this equipment.

Materials required

Only standard hand tools are required to install and service this equipment.

Before Installing Belt Tracking System

IMPORTANT

The delivery service is responsible for damage occurring in transit. Martin Engineering CANNOT enter claims for damages. Contact your transportation agent for more information.

1. Inspect shipping container for damage. Report damage to delivery service immediately and fill out delivery service's claim form. Keep any damaged goods subject to examination.
2. Remove Martin® Tracker™ Reversing from shipping container. Equipment in container should include the following:
 - Martin® Tracker™ Reversing (upper or lower guide unit).
 - Two Conveyor Products Warning Labels, P/N 23395.
 - Three Pinch Point Warning Labels, P/N 30528.
3. If anything is missing, contact Martin Engineering or a representative.
4. Make sure belt is centered on conveyor.



WARNING

Before installing equipment, turn off and lock out/tag out energy source to conveyor and conveyor accessories.

5. Turn off and lock out/tag out energy source according to ANSI standards (see “References”).

WARNING

If equipment will be installed in an enclosed area, gas level or dust content must be tested before using a cutting torch or welding. Using a cutting torch or welding in an area with gas or dust may cause an explosion.

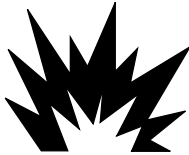

6. If using a cutting torch or welding, test atmosphere for gas level or dust content. Cover conveyor belt with fire retardant cover.

Installing Belt Tracking System

Installing lower guide unit

1. Locate lower guide unit approximately three times the belt width before the point where belt adjustment is needed or before any major pulley. If installing multiple units, allow 70 to 150 ft. (21 to 50 m) between units depending on the severity of mistracking.
2. Remove existing return idler. Set aside for later use.

IMPORTANT

For belts 24 to 54 in. (600 to 1600 mm) wide, min. 17 in. (430 mm) clearance between belt line and any obstruction below is required. For belts 60 to 84 in. (1800 to 2400 mm) wide, min. 24 in. (610 mm) clearance between belt line and any obstruction below is required. Contact Martin Engineering for installation instructions for clearances less than those specified above.

3. See Figures 5 and 6 for air cylinder switching mechanism installation orientation.
4. See Figure 7 for electric actuator switching mechanism installation orientation.
5. Remove existing return idler.
6. Assemble existing return idler roller into Martin[®] Tracker[™] Reversing Lower Unit.
7. Center roller on Martin[®] Tracker[™] and secure with four set screws.

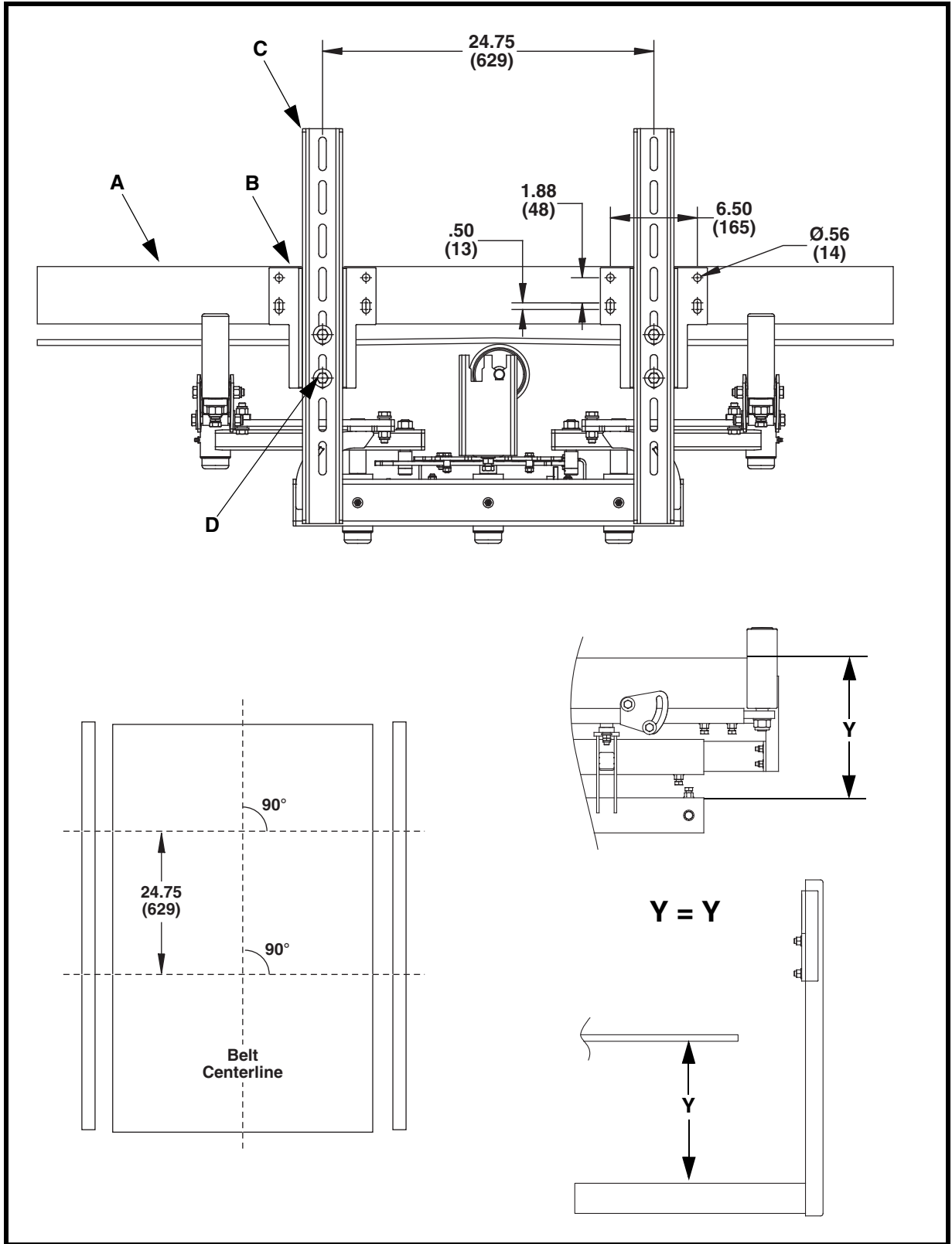

Figure 1. Mounting Dimensions–Martin® Tracker™ Reversing (Lower Unit)

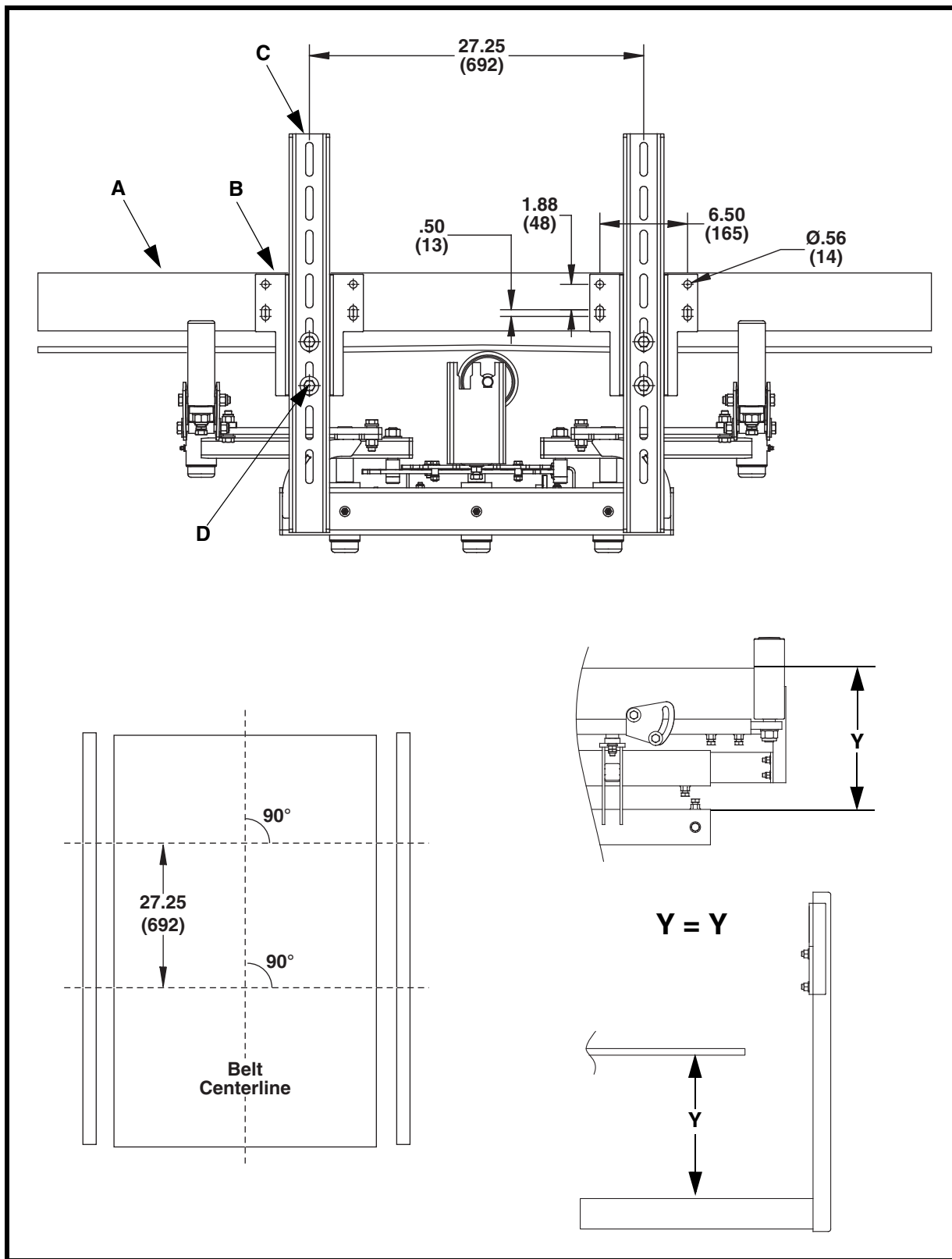

Figure 2. Mounting Dimensions–Martin® Tracker™ Reversing HD (Lower Unit)

NOTE

Martin Engineering recommends bolting rather than welding mounting brackets to stringers for easier accessibility and maintenance.

8. Mark location of mounting brackets (B) on stringers (A). See Figure 1 or 2 for mounting dimensions. Make sure telescoping tube mounting holes are accessible from both sides.
9. Bolt or weld mounting brackets to stringers as follows:
 - a. If bolting, drill or cut 9/16-in. holes in stringers through mounting holes in brackets. Install cap screw, flat washers compression washer, and nut in each hole to secure mounting brackets to stringers.
 - b. If welding, clean stringer of rust and dirt. Then weld mounting brackets to stringers.
10. Mount telescoping tubes (C) on farside stringer using cap screws, flat washers, compression washers, and nuts (D).
11. Slide Martin[®] Tracker[™] Reversing assembly onto telescoping tubes.
12. Slide operator side telescoping tubes into Martin[®] Tracker[™] Reversing assembly and fasten to mounting brackets using cap screws, flat washers, compression washers, and nuts (D).
13. Center assembly on belt and tighten telescoping tube set screws.
14. Raise entire assembly up into belt 1 inch and tighten mounting bolts.
15. Position each sensing roll 1/4 inch from belt and tighten set screws.
16. Adjust telescoping tubes so return idler firmly contacts belt. Fine tune position of unit by sliding it up or down before tightening hardware.

Installing upper guide unit

1. Locate upper guide unit beyond the loading point or three to four times the belt width before the point where belt needs adjustment. If installing multiple units, allow 70 to 150 ft. (21 to 50 m) between units depending on the severity of mistracking.
2. Remove belt (if possible) to provide work room.
3. See Figures 5 and 6 for air cylinder switching mechanism installation orientation.
4. See Figure 7 for electric actuator switching mechanism installation orientation.
5. Remove troughing idler.
6. Bolt or weld existing troughing idler onto Martin[®] Tracker[™] Reversing Upper Unit.

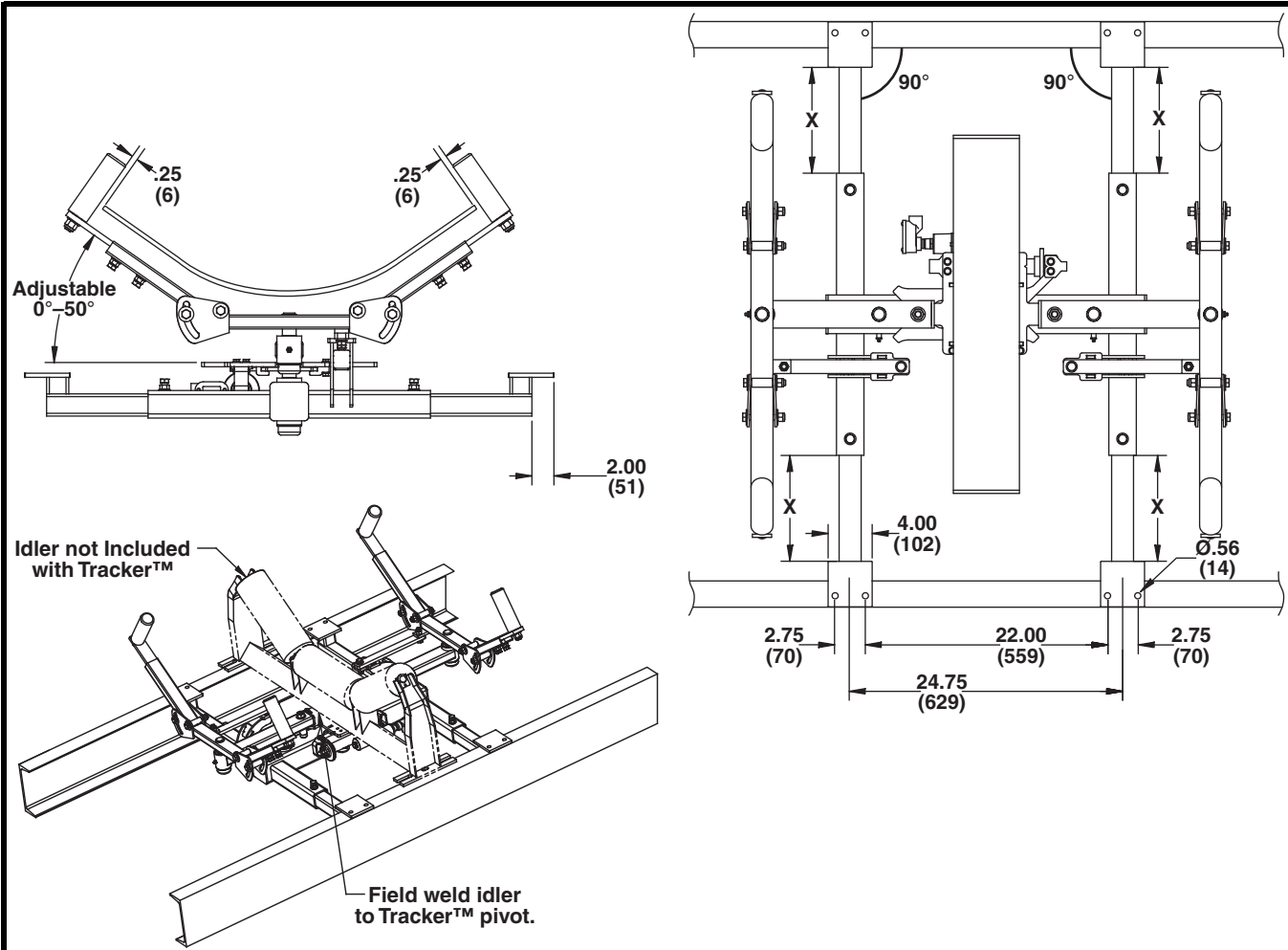

Figure 3. Mounting Dimensions–Martin® Tracker™ Reversing (Upper Unit)

7. Mark location of support arms (B) on stringers (A). See Figure 3 or 4 for mounting dimensions.
8. Drill or cut 9/16-in. holes in stringers through mounting holes in brackets.
9. Mount support arms (B) on farside stringer using cap screws, flat washers, compression washers, and nuts (D).
10. Slide Martin® Tracker™ Reversing assembly onto support arms.
11. Slide operator side support arms into Martin® Tracker™ Reversing assembly and fasten to mounting brackets using cap screws, flat washers, compression washers, and nuts (D).
12. Center assembly on belt and tighten support arm set screws.
13. Position each sensing roll 1/4 inch from belt and tighten set screws.

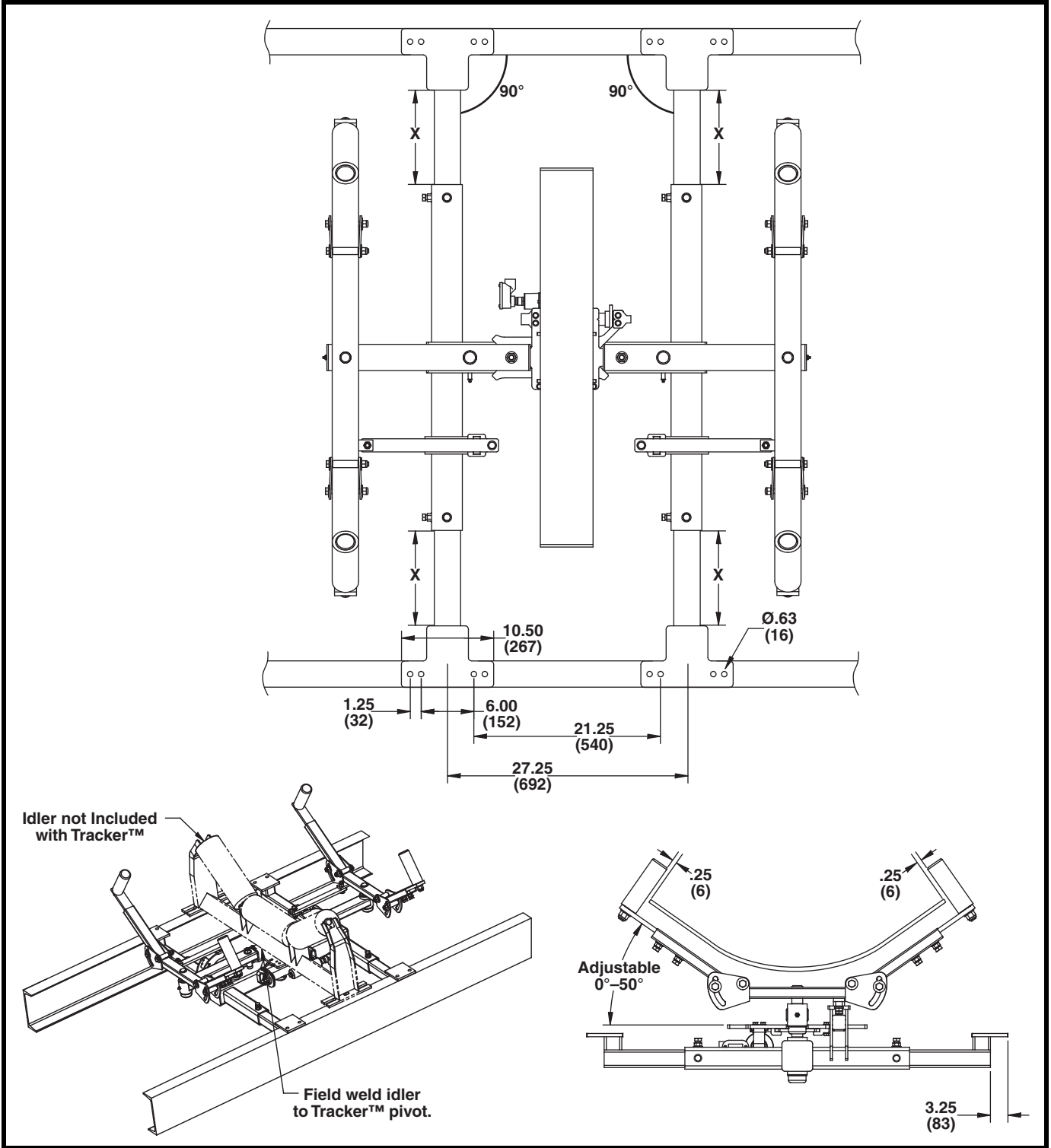

Figure 4. Mounting Dimensions–Martin® Tracker™ Reversing HD (Upper Unit)

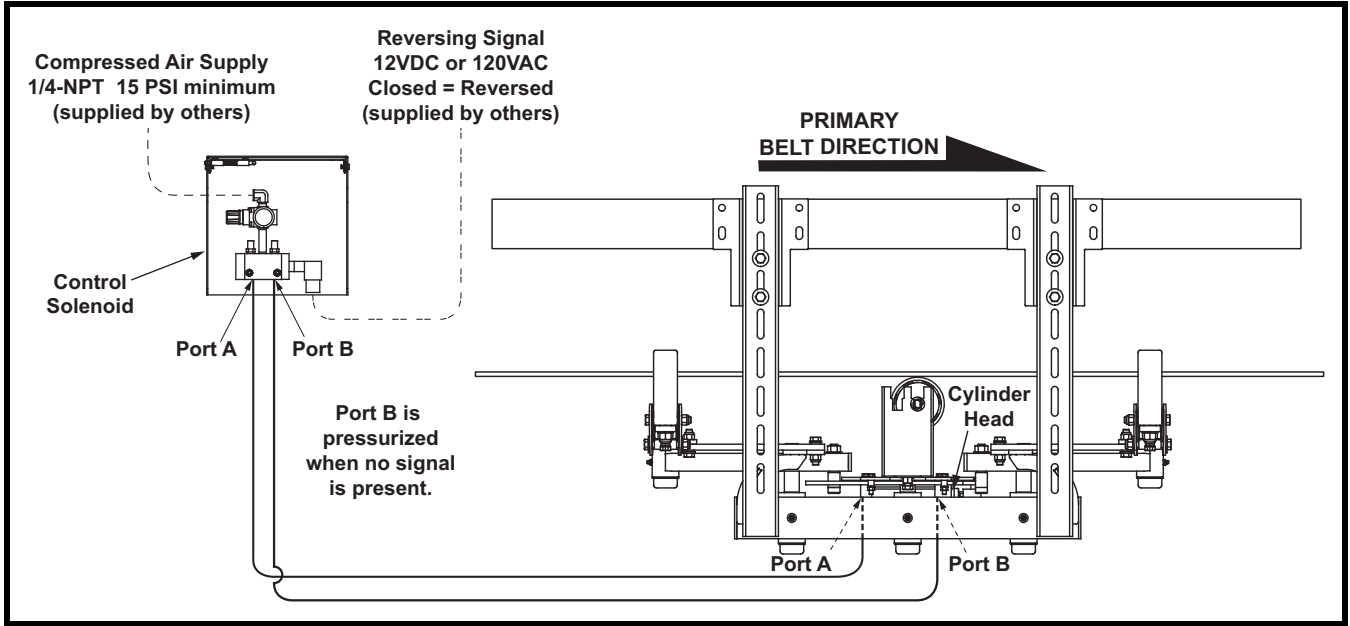

Figure 5. Air Cylinder Controls

Installing air cylinder controls

⚠ WARNING

All electrical work must be done to National Electrical Code (NEC) standards.

⚠ CAUTION

Do not mount control solenoid in area subject to shock, vibration, temperatures exceeding 130°F (55°C), or explosion.

1. Determine location for control solenoid and mount onto wall with fasteners.
2. Using electrical connectors, route wires from solenoid valve to direction monitoring hardware.
3. Wire solenoid so circuit will close when conveyor changes direction.

IMPORTANT

Martin Engineering recommends installing an air filter in the air supply line.

4. Install air supply line to control solenoid as shown in Figure 5.
5. Route two air lines from control solenoid to air cylinder.
6. Install elbows into ports on air cylinder.
7. Connect one air line to port A on solenoid valve and port A on air cylinder.
8. Connect other air line to port B on solenoid valve and port B on air cylinder.

9. Make sure air lines are not subject to wear or pinching. Anchor lines to prevent movement.
10. Apply air pressure to control solenoid.

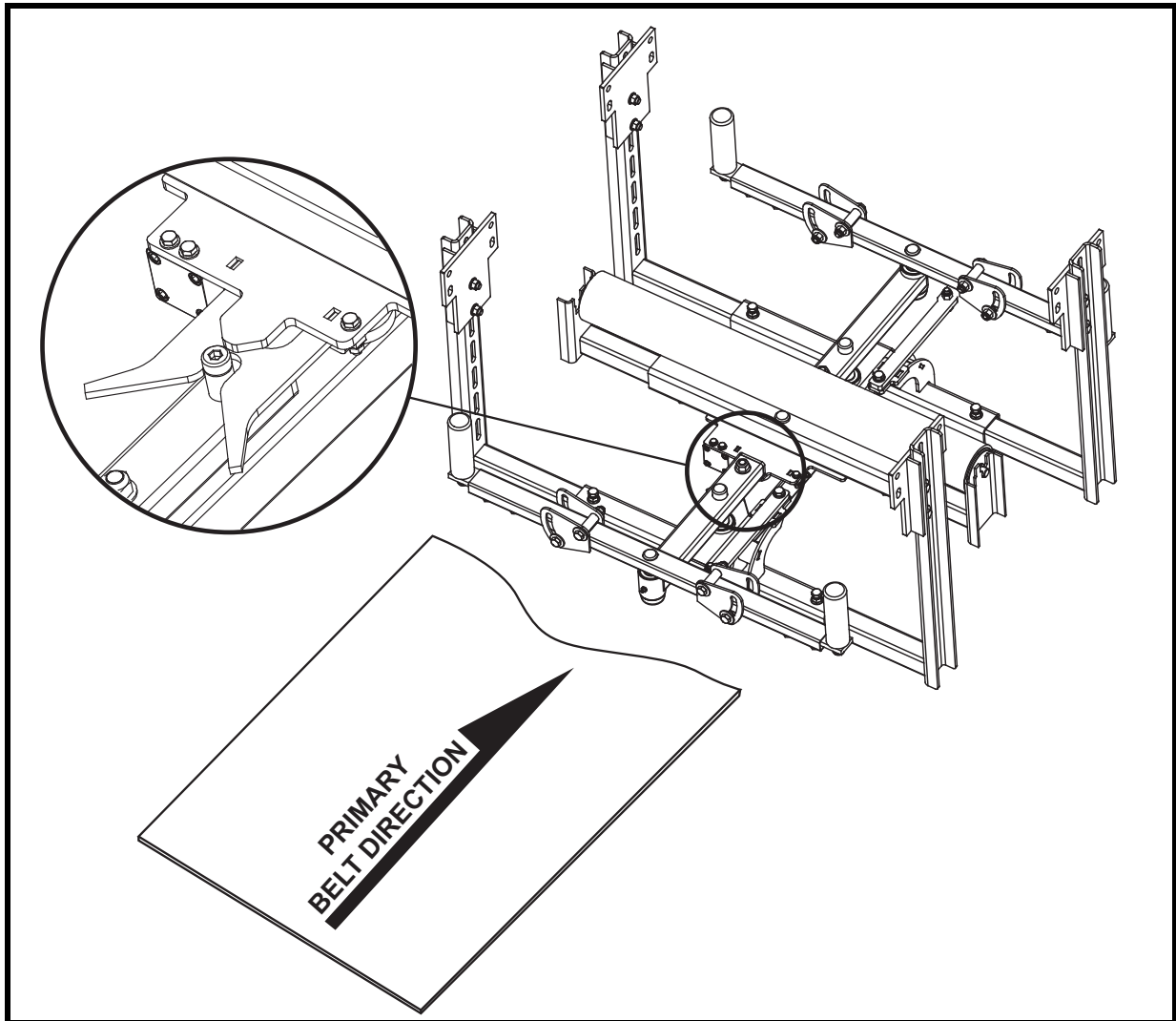

Figure 6. Air Cylinder Switching Mechanism Orientation

11. Air cylinder switching mechanism should be installed so the cylinder is retracted and double v-latch near the cylinder cap end is engaged when the conveyor belt is rotating in its primary direction.
12. If double v-latch is not engaged on the correct side:
 - a. Switch air lines between ports A and B on cylinder.
13. If cylinder is extended when the belt is traveling in its primary direction:
 - a. Remove switching mechanism assembly.
 - b. Rotate mechanism 180 degrees.
 - c. Reinstall switching mechanism assembly.

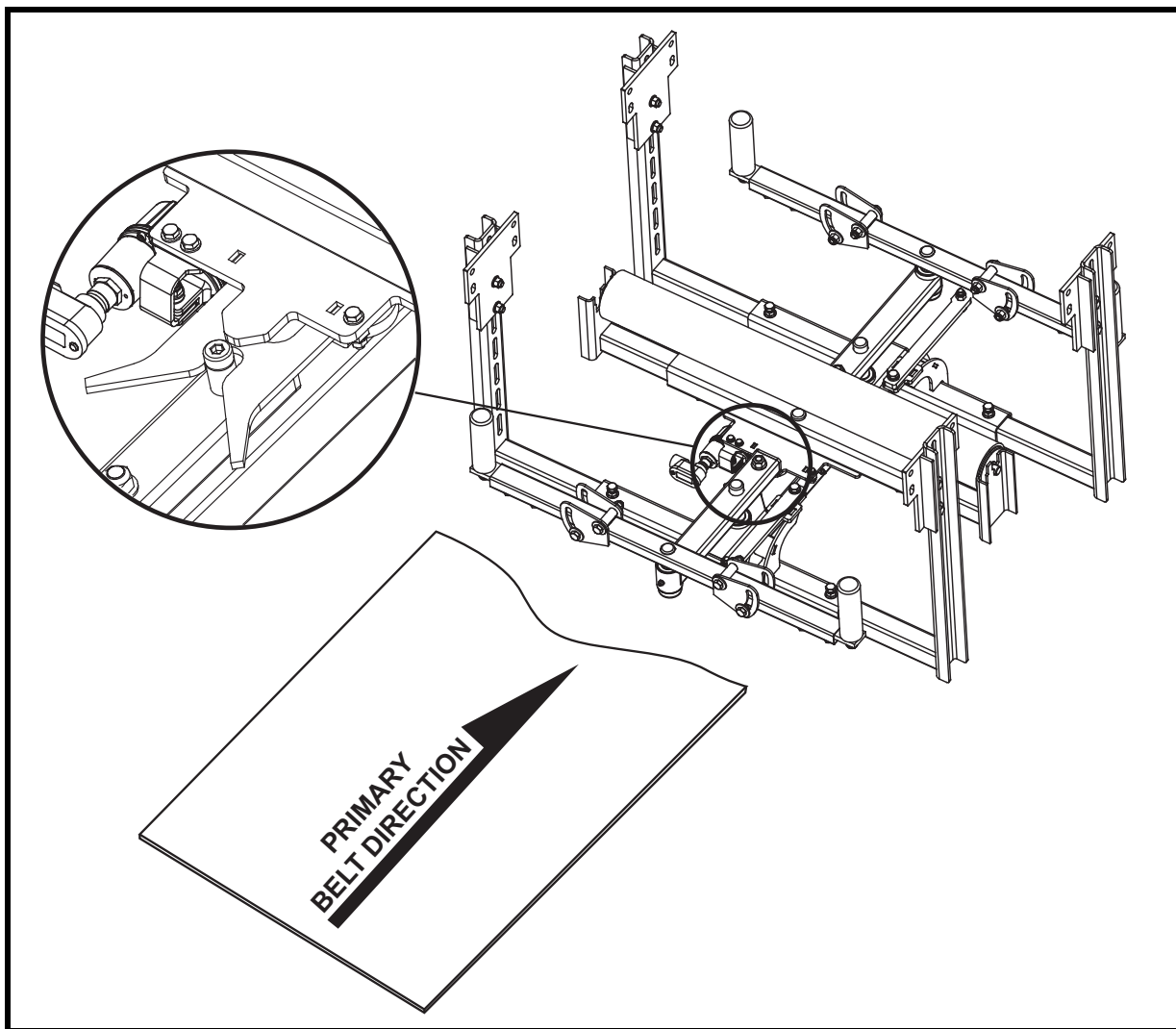

Figure 7. Electric Actuator Switching Mechanism Orientation

Installing electric actuator controls

1. Electric actuator switching mechanism should be installed so the actuator is retracted and double v-latch near the actuator cap end is engaged when the conveyor belt is rotating in its primary direction.
2. If double v-latch is not engaged on the correct side:
 - a. Remove yellow jumper wire on control panel PLC as shown in *Martin® Tracker™ Reversing Control Panel Operator's Manual, P/N 4073*.
3. If actuator is extended when the belt is traveling in its primary direction:
 - a. Remove switching mechanism assembly.
 - b. Rotate mechanism 180 degrees.
 - c. Reinstall switching mechanism assembly.
4. Refer to *Martin® Tracker™ Reversing Control Panel Operator's Manual, P/N 4073* for complete instructions regarding electric actuator controls installation.

After Installing Belt Tracking System

IMPORTANT

Read entire section before beginning work.

CAUTION

Martin Engineering recommends installing run-off sensors on conveyor. If switching mechanism fails, belt could be damaged.

1. Thoroughly wipe chute or stringers clean above Martin® Tracker™ Reversing on both sides of belt. Place Conveyor Products Warning Labels (P/N 23395) on chute or stringers visible to Martin® Tracker™ Reversing operator.

WARNING

Failure to remove tools from installation area and conveyor belt before turning on energy source can cause serious injury to personnel and damage to belt.

2. Remove all tools and fire retardant cover from installation area and conveyor belt.

DANGER

Do not touch or go near conveyor belt or conveyor accessories when conveyor belt is running. Body or clothing can get caught and pull body into conveyor belt, causing severe injury or death.

3. Turn on conveyor belt and observe belt tracking.

WARNING

Before adjusting Martin® Tracker™ Reversing, turn off and lock out/tag out energy source to conveyor and conveyor accessories.

4. Allow belt to run through at least ten revolutions in one direction. Reverse direction of belt and run through at least ten revolutions in the opposite direction. Then turn off and lock out/tag out energy source according to ANSI standards (see “References”).
5. Make sure all fasteners are tight. Tighten if necessary.

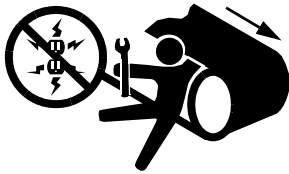
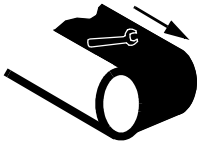

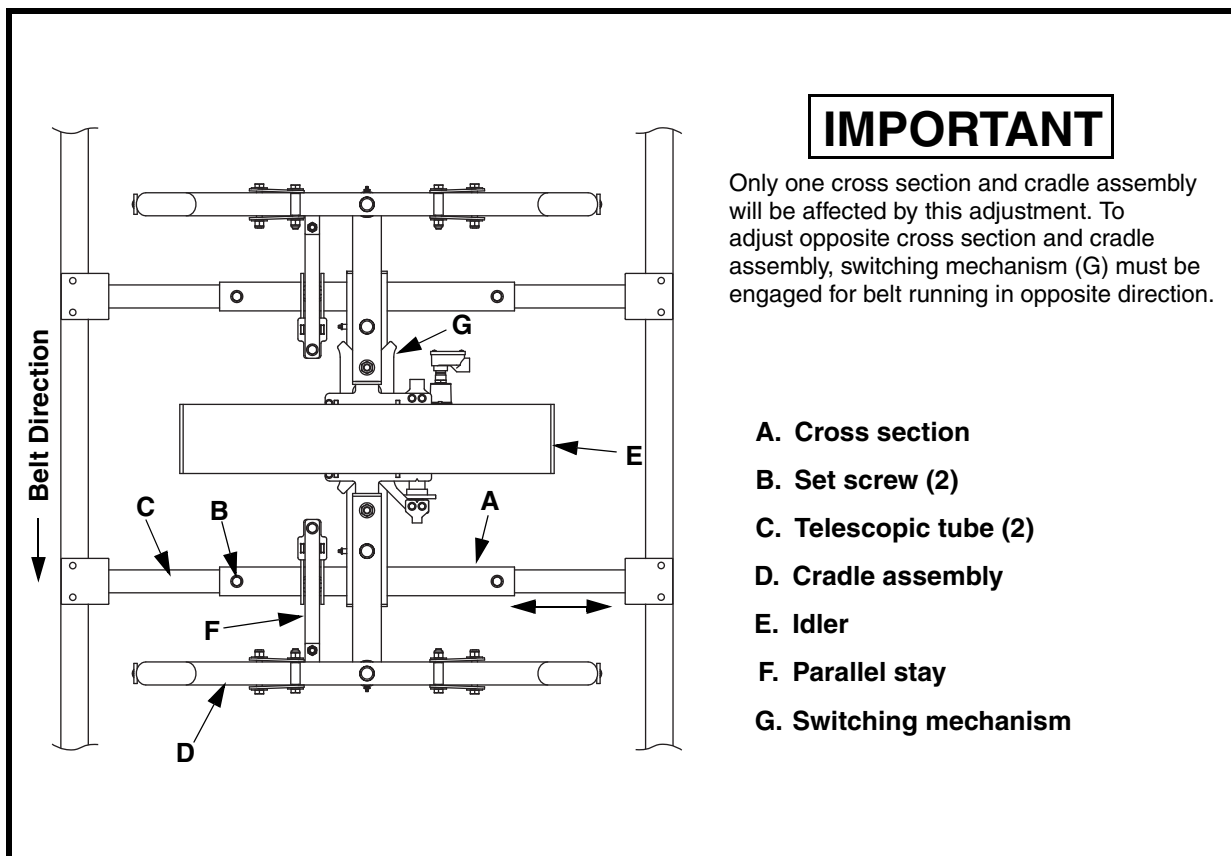

Figure 8. Adjusting Martin® Tracker™ Reversing

6. See Figure 8. If necessary, adjust cross section (A) to fine tune belt tracking:
 - a. Loosen set screws (B) securing cross section on telescopic tubes (C).
 - b. Slide cross section on telescopic tubes in the direction belt needs to move as necessary for proper adjustment of cradle assembly (D) and idler (E). (Parallel stay (F) will move cradle assembly.)

Part Numbers

This section provides part numbers for the Martin® Tracker™ Systems. Please reference part numbers when ordering parts.

Martin® Tracker™ Assemblies

Martin® Tracker™ Reversing Upper Unit Assemblies: 24 to 54 in. (600 to 1400-mm) belts: P/N TKR-XXURSXXX-XXX.

Martin® Tracker™ Reversing HD Upper Unit Assemblies: 36 to 72-in. (800 to 1800-mm) belts: P/N TKR-XXURHXXX-XXX.

Martin® Tracker™ Reversing Lower Unit Assemblies: 24 to 54 in. (600 to 1400-mm) belts: P/N TKR-XXLRSXXX-XXX.

Martin® Tracker™ Reversing HD Lower Unit Assemblies: 36 to 84-in. (800 to 2200-mm) belts: P/N TKR-XXLRHXXX-XXX.

NOMENCLATURE

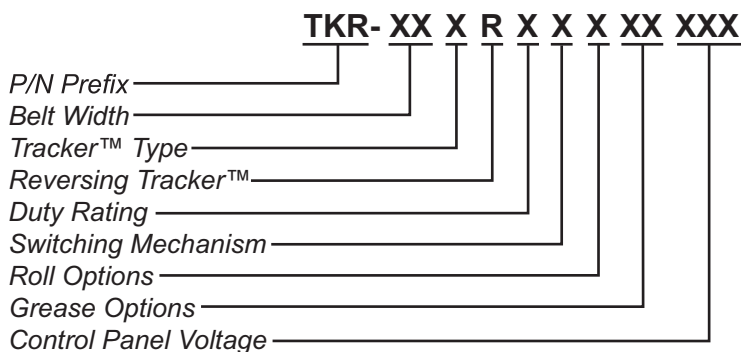

TRACKER™ TYPE

U: Upper Tracker™
L: Lower Tracker™

DUTY RATING

S: Standard Duty
H: Heavy Duty

SWITCHING MECHANISM

A: Air Cylinder
E: 24V Actuator

ROLL OPTIONS

R: With Roll (Lower Tracker™ only)
Blank: Without Roll

GREASE OPTIONS

G: With Grease Kit
Blank: Without Grease Kit

CONTROL PANEL VOLTAGE

(Tracker™ with Air Cylinder only)
24: 24V DC
120: 120V AC
Blank: Without Control Panel

Martin® Return Roll

Rubber Lagged Return Roll: P/N TRLRLXX-XX
(First X indicates CEMA classification; second X indicates roll diameter; last XX indicates belt width.)

Martin® Guide Roll Repair Kits

Guide Roll Repair Kit: P/N 35205-XX. (Includes Arm, Bearings, and Roller)

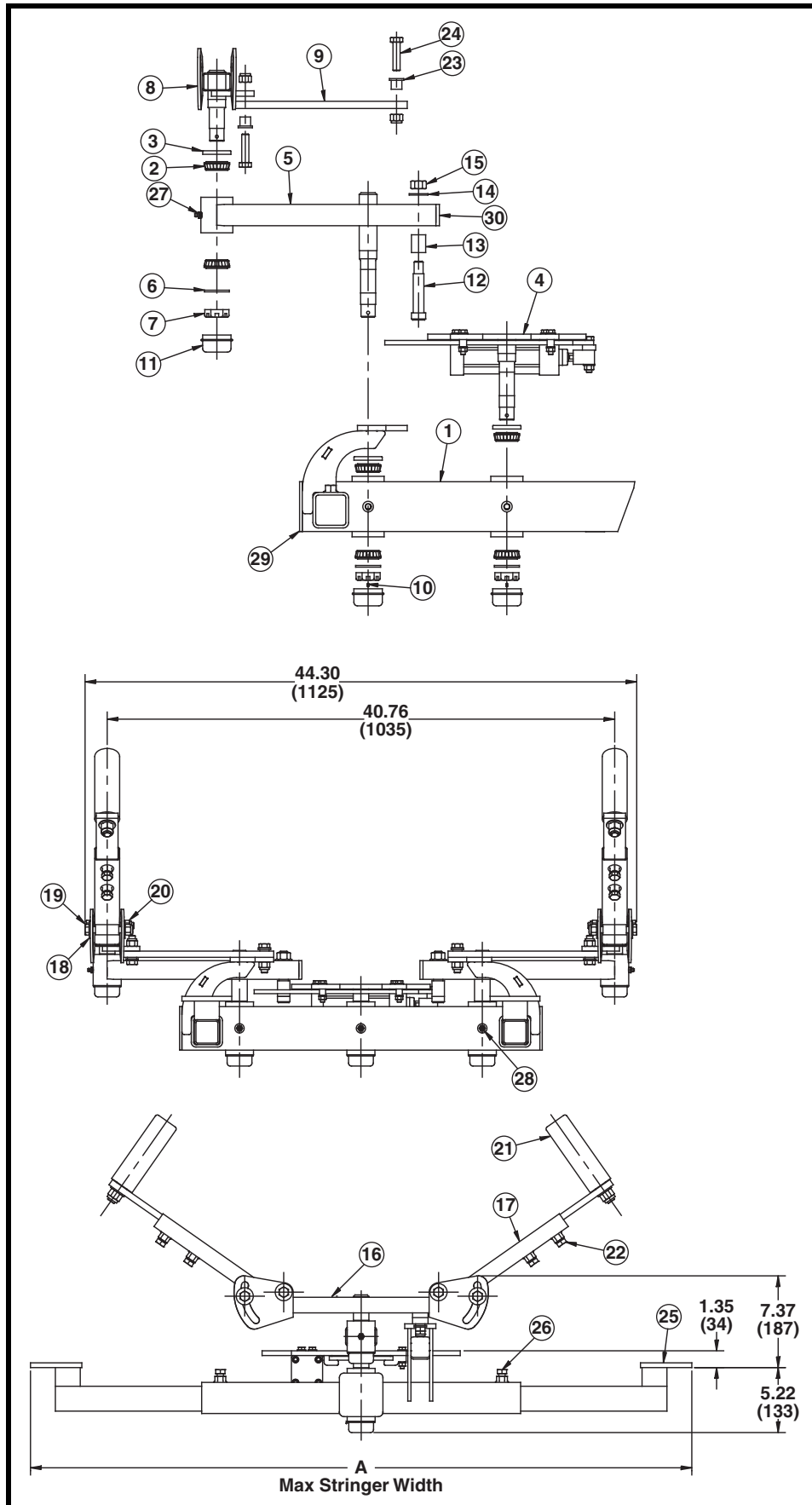

Figure 9. Martin® Tracker™ Reversing (Upper Unit), P/N TKR-XXURSXXX-XXX

Item	Description	Part No.	Qty
1	H-Frame Weldment	38504R-02	1
2	Bearing Tapered Roller	38505-01	10
3	Seal Bearing	38516-S	5
4	Switching Unit Assembly - Air Cylinder	35662R-00A-XXX	1
	Switching Unit Assembly - 24V Actuator	35662R-00E	
5	Torque Arm Tube Weldment	38510-S	2
6	Washer Bearing	38513	5
7	Nut Bearing	38514	5
8	Cradle Weldment	38512-02	1
9	Parallel Stay	37415R-01	2
10	Pin Cotter 1/8 x 1-3/4 ZP	14210	5
11	Dust Cap Bearing	38515-S	5
12	Screw SOC HD Shoulder 3/4 x 2-3/4	37267	2
13	Torque Arm Bushing	37268	2
14	Washer Compression 5/8	11752	2
15	Nut Hex 5/8-11NC ZP	11772	2
16	Cradle Weldment	38512R-02	1
17	Wing Tube Weldment	Table I	4
18	Washer Flat 1/2 Wide ZP	17328	16
19	Screw HHC 1/2-13NC x 1-1/4 ZP	M921	8
20	Nut Hex Elastic Lock 1/2-13NC ZP	18577	12
21	Guide Roll Arm Assembly	Table I	4
22	Screw HHC 1/2-13NC x 1-1/4 ZP	13835	Table I
23	Sleeve Bearing	38423	4
24	Screw HHC 1/2-13NC x 2 ZP	14196	4
25	Support Arm Weldment	Table I	4
26	Screw HHC 1/2-13NC x 1 ZP	13842	4
27	Fitting Grease 1/8-27 NPT	11814	2
28	Extended Fitting Grease 1/8-27 NPT	38517	3
29	Plug for 3.50 Square Tube	37301	2
30	Plug for 2-1/2 x 1-1/2 Tube	34714	2
31 (NS)	Label Kit	34772-R	1
32 (NS)	Mounting Hardware Kit	34498	1
33 (NS)	Tracker Remote Grease Kit	Table I	1
34 (NS)	Operator's Manual	M4098	1

Figure 9. Martin® Tracker™ Reversing (Upper Unit), P/N TKR-XXURSXXX-XXX

Table I. Part Numbers and Quantities for Martin® Tracker™ Reversing Upper Unit

Assembly P/N	Item 17 P/N	Item 21 P/N	Item 25 P/N	Item 33 P/N	Item 22 Qty
TKR-24URSXXX	37458-02	35205-06	37413-502	38550R-1	2
TKR-30URSXXX	37458-02	35205-06	37413-502	38550R-1	2
TKR-36URSXXX	37466	35205-06	37413-503	38550R-1	4
TKR-42URSXXX	37466	35205-02	37413-504	38550R-1	4
TKR-48URSXXX	37466	35205-02	37413-504	38550R-1	4
TKR-54URSXXX	37466	35205-02	37413-505	38550R-2	4

Table II. Dimensions and Weights for Martin® Tracker™ Reversing Upper Unit

Assembly P/N	Belt Width in. (mm)	Dim "A"	Weight lbs
TKR-24URSXXX	24-30 (600-800)	49.12 (1248)	172
TKR-30URSXXX	24-30 (600-800)	49.12 (1248)	172
TKR-36URSXXX	36 (950)	53.12 (1349)	178
TKR-42URSXXX	42-48 (1000-1250)	66.88 (1699)	196
TKR-48URSXXX	42-48 (1000-1250)	66.88 (1699)	196
TKR-54URSXXX	54 (1350)	71.12 (1806)	198

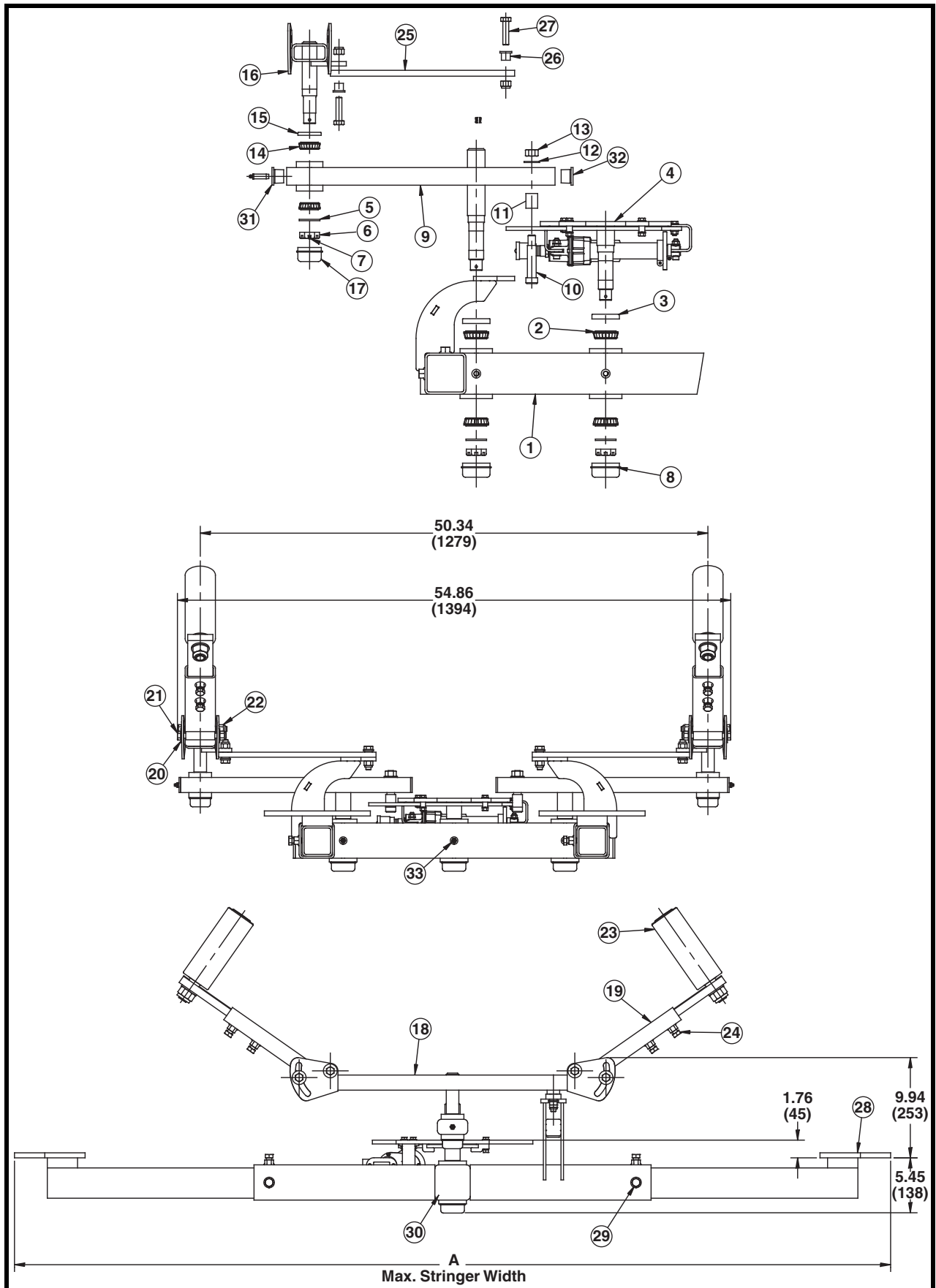

Figure 10. Martin® Tracker™ Reversing HD (Upper Unit), P/N TKR-XXURHXXX-XXX

Part Numbers

Item	Description	Part No.	
1	H-Frame Weldment	Table III	1
2	Bearing Tapered Roller	38505-02	6
3	Seal Bearing	38516-H	3
4	Switching Unit Assembly - Air Cylinder	35662R-01A-XXX	1
	Switching Unit Assembly - 24V Actuator	35662R-01E	
5	Washer Bearing	38513	5
6	Nut Bearing	38514	5
7	Pin Cotter 1/8 x 1-3/4 ZP	14210	5
8	Dust Cap Bearing	38515-H	3
9	Torque Arm Tube Weldment	38510-H	2
10	Screw SOC HD Shoulder 3/4 x 2-3/4	37267	2
11	Torque Arm Bushing	37268	2
12	Washer Compression 5/8	11752	2
13	Nut Hex 5/8-11NC ZP	11772	2
14	Bearing Tapered Roller	38505-01	4
15	Seal Bearing	38516-S	2
16	Cradle Weldment	Table III	1
17	Dust Cap Bearing	38515-S	2
18	Cradle	Table III	1
19	Wing Tube Weldment	Table III	4
20	Washer Flat 1/2 Wide ZP	17328	16
21	Screw HHC 1/2-13NC x 4-1/2 ZP	35170	8
22	Nut Elastic Lock 1/2-13NC ZP	18577	12
23	Roller Assembly	Table III	4
24	Screw HHC 1/2-13NC x 1-1/4 ZP	13835	8
25	Parallel Stay	37415R-02	2
26	Sleeve Bearing	38423	4
27	Screw HHC 1/2-13NC x 2 ZP	14196	4
28	Support Arm Weldment	Table III	4
29	Screw HHC 1/2-13NC x 1 ZP	13842	8
30	Plug for 3.50 Square Tube	37301	2
31	Plug for 3.00 x 1.50 Tube	37303-2	2
32	Plug for 3.00 x 1.50 Tube	37303	2
33	Extended Fitting Grease 1/8-27 NPT	38517	5
34 (NS)	Label Kit	34772-R	1
35 (NS)	Mounting Hardware Kit	31033	1
36 (NS)	Tracker Remote Grease Kit	Table III	1
37 (NS)	Operator's Manual	M4098	1

Figure 10. Martin[®] Tracker[™] Reversing HD (Upper Unit), P/N TKR-XXURHXXX-XXX

Table III. Part Numbers and Quantities for Martin® Tracker™ Reversing HD Upper Unit

Assembly P/N	Item 1 P/N	Item 16 P/N	Item 18 P/N	Item 19 P/N	Item 23 P/N	Item 28 P/N	Item 36 P/N
TKR-36URHXXX	38504R-05	38512-05	38512R-05	37283-03	35205-07	37413-H01	38550R-1
TKR-42URHXXX	38504R-03	38512-03	38512R-03	37283-03	35205-07	37413-H01	38550R-1
TKR-48URHXXX	38504R-03	38512-03	38512R-03	37283-01	35205-03	37413-H02	38550R-1
TKR-54URHXXX	38504R-03	38512-03	38512R-03	37283-01	35205-03	37413-H02	38550R-2
TKR-60URHXXX	38504R-04	38512-04	38512R-04	37283-01	35205-03	37413-H03	38550R-2
TKR-72URHXXX	38504R-04	38512-04	38512R-04	37283-01	35205-04	37413-H03	38550R-2

Table IV. Dimensions and Weights for Martin® Tracker™ Reversing HD Upper Unit

Assembly P/N	Belt Width in. (mm)	Dim "A"	Weight lbs
TKR-36URHXXX	36 (800-1000)	65.88 (1673)	337
TKR-42URHXXX	42 (1000-1200)	74.88 (1902)	357
TKR-48URHXXX	48 (1200-1400)	86.88 (2207)	386
TKR-54URHXXX	54 (1400-1600)	86.88 (2207)	386
TKR-60URHXXX	60-72 (1600-1750)	104.76 (2661)	415
TKR-72URHXXX	60-72 (1600-1750)	104.76 (2661)	426

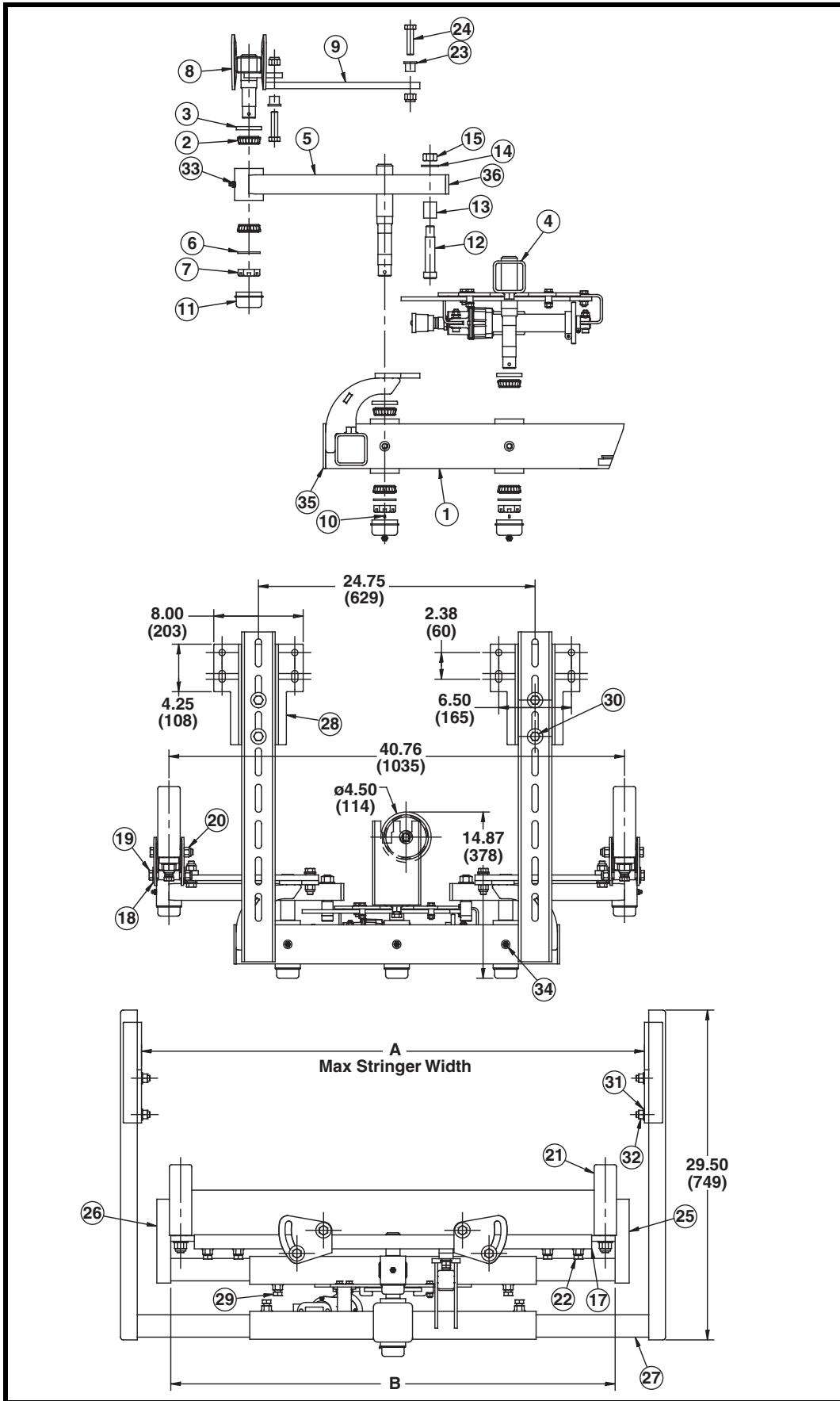

Figure 11. Martin® Tracker™ Reversing (Lower Unit), P/N TKR-XXLRSXXX-XXX

Item	Description	Part No.	
1	H-Frame Weldment	38504R-02	1
2	Bearing Tapered Roller	38505-01	10
3	Seal Bearing	38516-S	5
4	Switching Unit Assembly - Air Cylinder	35661R-02A-XXX	1
	Switching Unit Assembly - 24V Actuator	35661R-02E	
5	Torque Arm Tube Weldment	38510-S	2
6	Washer Bearing	38513	5
7	Nut Bearing	38514	5
8	Cradle Weldment	38512-02	1
9	Parallel Stay	37415R-01	2
10	Pin Cotter 1/8 x 1-3/4 ZP	14210	5
11	Dust Cap Bearing	38515-S	5
12	Screw SOC HD Shoulder 3/4 x 2-3/4	37267	2
13	Torque Arm Bushing	37268	2
14	Washer Compression 5/8	11752	2
15	Nut Hex 5/8-11NC ZP	11772	2
16	Cradle Weldment	38512R-02	1
17	Wing Tube Weldment	Table V	4
18	Washer Flat 1/2 Wide ZP	17328	24
19	Screw HHC 1/2-13NC x 3-1/2 ZP	M921	8
20	Nut Elastic Lock 1/2-13NC ZP	18577	12
21	Guide Roll Arm Assembly	Table V	4
22	Screw HHC 1/2-13NC x 1-1/4 ZP	13835	Table V
23	Sleeve Bearing	38423	4
24	Screw HHC 1/2-13NC x 2 ZP	14196	4
25	Telescoping Idler Tube Weldment	Table V	1
26	Telescoping Idler Tube Weldment	Table V	1
27	Telescoping Tube Weldment	Table V	4
28	Hanger Plate Weldment	37396-01	4
29	Screw HHC 1/2-13NC x 1 ZP	13842	6
30	Screw HHC 1/2-13NC x 1-1/2 ZP	11763	8
31	Washer Compression 1/2	11750	8
32	Nut Hex 1/2-13NC ZP	11771	8
33	Fitting Grease 1/8-27 NPT	11814	2
34	Extended Fitting Grease 1/8-27 NPT	38517	3
35	Plug for 3.50 Square Tube	37301	2
36	Plug for 2-1/2 x 1-1/2 Tube	34714	2
37 (NS)	Label Kit	34772-R	1
38 (NS)	Mounting Hardware Kit	31033	1

Item	Description	Part No.	
39 (NS)	Tracker Remote Grease Kit	Table V	1
40 (NS)	Operator's Manual	M4098	1
41 (NS)	Return Roll with Rubber Lagging	Table V	1

Figure 11. Martin® Tracker™ Reversing (Lower Unit), P/N TKR-XXLRSEXX-XXX

Table V. Part Numbers and Quantities for Martin® Tracker™ Reversing Lower Unit

Assembly P/N	Item 17 P/N	Item 21 P/N	Item 25 P/N	Item 26 P/N	Item 27 P/N	Item 39 P/N	Item 41 P/N	tem 22 Qty
TKR-24LRSEXX	37458-02	35205-06	34745-03R	34745-03L	34743-01	38550R-1	TRLRLC4-24	2
TKR-30LRSEXX	37458-02	35205-06	34745-01R	34745-01L	34743-01	38550R-1	TRLRLC4-30	2
TKR-36LRSEXX	37466	35205-06	34745-01R	34745-01L	34743-01	38550R-1	TRLRLC4-36	4
TKR-42LRSEXX	37466	35205-02	34745-02R	34745-02L	34743-02	38550R-1	TRLRLC4-42	4
TKR-48LRSEXX	37466	35205-02	34745-02R	34745-02L	34743-02	38550R-1	TRLRLC4-48	4
TKR-54LRSEXX	37466	35205-02	34745-02R	34745-02L	34743-02	38550R-2	TRLRLC4-54	4

Table VI. Dimensions and Weights for Martin® Tracker™ Reversing Lower Unit

Assembly P/N	Belt Width in. (mm)	Dim "A"	Dim "B"		Weight lbs
			Min.	Max.	
TKR-24LRSEXX	24 (600-700)	51.12 (1298)	21.00 (533)	38.63 (981)	258
TKR-30LRSEXX	30 (700-800)	51.12 (1298)	29.50 (749)	47.13 (1197)	260
TKR-36LRSEXX	36 (800-1000)	51.12 (1298)	29.50 (749)	47.13 (1197)	264
TKR-42LRSEXX	42 (1000-1200)	66.80 (1697)	42.50 (1080)	60.13 (1527)	285
TKR-48LRSEXX	48 (1200-1400)	66.80 (1697)	42.50 (1080)	60.13 (1527)	285
TKR-54LRSEXX	54 (1400-1600)	66.80 (1697)	42.50 (1080)	60.13 (1527)	285

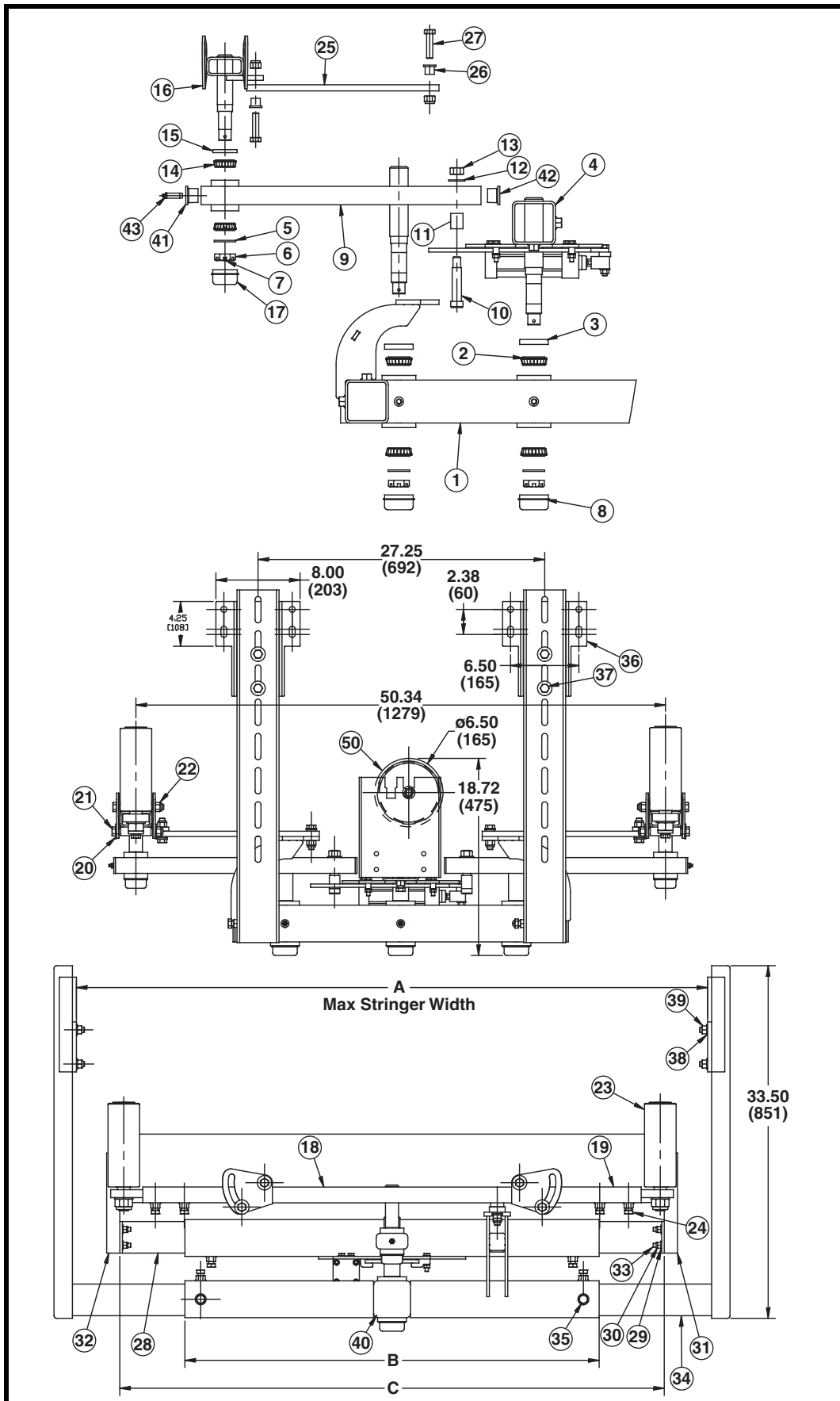

Figure 12. Martin® Tracker™ Reversing HD (Lower Unit), P/N TKR-XXLRHXXX-XXX

Part Numbers

Item	Description	Part No.	
1	H-Body	Table VII	1
2	Bearing Tapered Roller	38505-02	6
3	Seal Bearing	38516-H	3
4	Switching Unit Assembly	Table VII	1
5	Washer Bearing	38513	5
6	Nut Bearing	38514	5
7	Pin Cotter 1/8 x 1-3/4 ZP	14210	5
8	Dust Cap Bearing	38515-H	3
9	Torque Arm Tube Weldment	38510-H	2
10	Screw SOC HD Shoulder 3/4 x 2-3/4	37267	2
11	Torque Arm Bushing	37268	2
12	Washer Compression 5/8	11752	2
13	Nut Hex 5/8-11NC ZP	11772	2
14	Bearing Tapered Roller	38505-01	4
15	Seal Bearing	38516-S	2
16	Cradle Weldment	Table VII	1
17	Dust Cap Bearing	38515-S	2
18	Cradle Weldment	Table VII	1
19	Wing Tube Weldment	Table VII	4
20	Washer Flat 1/2 Wide ZP	17328	24
21	Screw HHC 1/2-13NC x 4-1/2 ZP	35170	8
22	Nut Elastic Lock 1/2-13NC ZP	18577	12
23	Roller Assembly	Table VII	4
24	Screw HHC 1/2-13NC x 1-1/4 ZP	13835	8
25	Parallel Stay	37415R-02	2
26	Sleeve Bearing	38423	4
27	Screw HHC 1/2-13NC x 2 ZP	14196	4
28	Telescoping Idler Tube Weldment	Table VII	2
29	Washer Compression 3/8	11747	8
30	Nut Elastic Lock 3/8-16NC Z	14201	8
31	Telescoping Tube Upright	38029-00RP	1
32	Telescoping Tube Upright	38029-00LP	1
33	Screw HHC 3/8-16NC x 1-1/4 ZP	12215	8
34	Telescoping Tube Weldment	Table VII	4
35	Screw HHC 1/2-13NC x 1 ZP	13842	12
36	Hanger Plate Weldment	37396-02	4
37	Screw HHC 1/2-13NC x 1-1/2 ZP	11763	8
38	Washer Compression 1/2	11750	8
39	Nut Hex 1/2-13NC ZP	11771	8

Item	Description	Part No.	
40	Plug for 3.50 Square Tube	37301	2
41	Plug for 3.00 x 1.50 Tube	37303-2	2
42	Plug for 3.00 x 1.50 Tube	37303	2
43	Extended Fitting Grease 1/8-27 NPT	38517	5
44	Telescoping Tube Upright	38029-01LP	1
45	Telescoping Tube Upright	38029-01RP	1
46 (NS)	Label Kit	34772-R	1
47 (NS)	Mounting Hardware Kit	31033	1
48 (NS)	Tracker Remote Grease Kit	Table VII	1
49 (NS)	Operator's Manual	M4098	1
50 (NS)	Return Roll with Rubber Lagging	Table VII	1

Figure 12. Martin[®] Tracker[™] Reversing HD (Lower Unit), P/N TKR-XXLRHXXX-XXX

Table VII. Part Numbers and Quantities for Martin[®] Tracker[™] Reversing HD Lower Unit

Assembly P/N	Item 1 P/N	Item 4 P/N	Item 16 P/N	Item 18 P/N	Item 19 P/N
TKR-36LRHAXX-XXX	38504R-05	35661R-05A-XXX	38512-05	38512R-05	37283-03
TKR-42LRHAXX-XXX	38504R-03	35661R-03A-XXX	38512-03	38512R-03	37283-03
TKR-48LRHAXX-XXX	38504R-03	35661R-03A-XXX	38512-03	38512R-03	37283-01
TKR-54LRHAXX-XXX	38504R-03	35661R-03A-XXX	38512-03	38512R-03	37283-01
TKR-60LRHAXX-XXX	38504R-04	35661R-04A-XXX	38512-04	38512R-04	37283-01
TKR-72LRHAXX-XXX	38504R-04	35661R-04A-XXX	38512-04	38512R-04	37283-01
TKR-84LRHAXX-XXX	38504R-04	35661R-04A-XXX	38512-04	38512R-04	37283-01

Assembly P/N	Item 23 P/N	Item 28 P/N	Item 34 P/N	Item 48 P/N	Item 50 P/N
TKR-36LRHAXX-XXX	35205-07	38031-H1	34743-06	38550R-1	TRLRLC6-36
TKR-42LRHAXX-XXX	35205-07	38031-H1	34743-04N	38550R-1	TRLRLC6-42
TKR-48LRHAXX-XXX	35205-07	38031-H1	34743-04N	38550R-1	TRLRLC6-48
TKR-54LRHAXX-XXX	35205-03	38031-H1	34743-04N	38550R-1	TRLRLC6-54
TKR-60LRHAXX-XXX	35205-04	38031-H2	34743-04	38550R-2	TRLRLC6-60
TKR-72LRHAXX-XXX	35205-04	38031-H2	34743-04	38550R-2	TRLRLC6-72
TKR-84LRHAXX-XXX	35205-04	38031-H3	34743-05	38550R-2	TRLRLC6-84

Table VIII. Dimensions and Weights for Martin® Tracker™ Reversing HD Lower Unit

Assembly P/N	Belt Width in. (mm)	Dim "A"	Dim "B"	Dim "C"		Weight lbs
				Min.	Max.	
TKR-36LRHAXX-XXX	36 (800-1000)	60.38 (1534)	30.38 (772)	33.26 (845)	53.64 (1362)	456
TKR-42LRHAXX-XXX	42 (1000-1200)	77.38 (1965)	39.38 (1000)	42.00 (1067)	65.38 (1661)	491
TKR-48LRHAXX-XXX	48 (1200-1400)	77.38 (1965)	39.38 (1000)	42.00 (1067)	73.38 (1864)	498
TKR-54LRHAXX-XXX	54 (1400-1600)	77.38 (1965)	39.38 (1000)	42.00 (1067)	81.38 (2067)	507
TKR-60LRHAXX-XXX	60 (1600-1800)	104.25 (2648)	47.25 (1200)	56.00 (1422)	95.25 (2419)	570
TKR-72LRHAXX-XXX	72 (1800-2000)	104.25 (2648)	47.25 (1200)	56.00 (1422)	95.25 (2419)	570
TKR-84LRHAXX-XXX	84 (2000-2200)	110.25 (2800)	47.25 (1200)	62.00 (1575)	111.25 (2826)	692

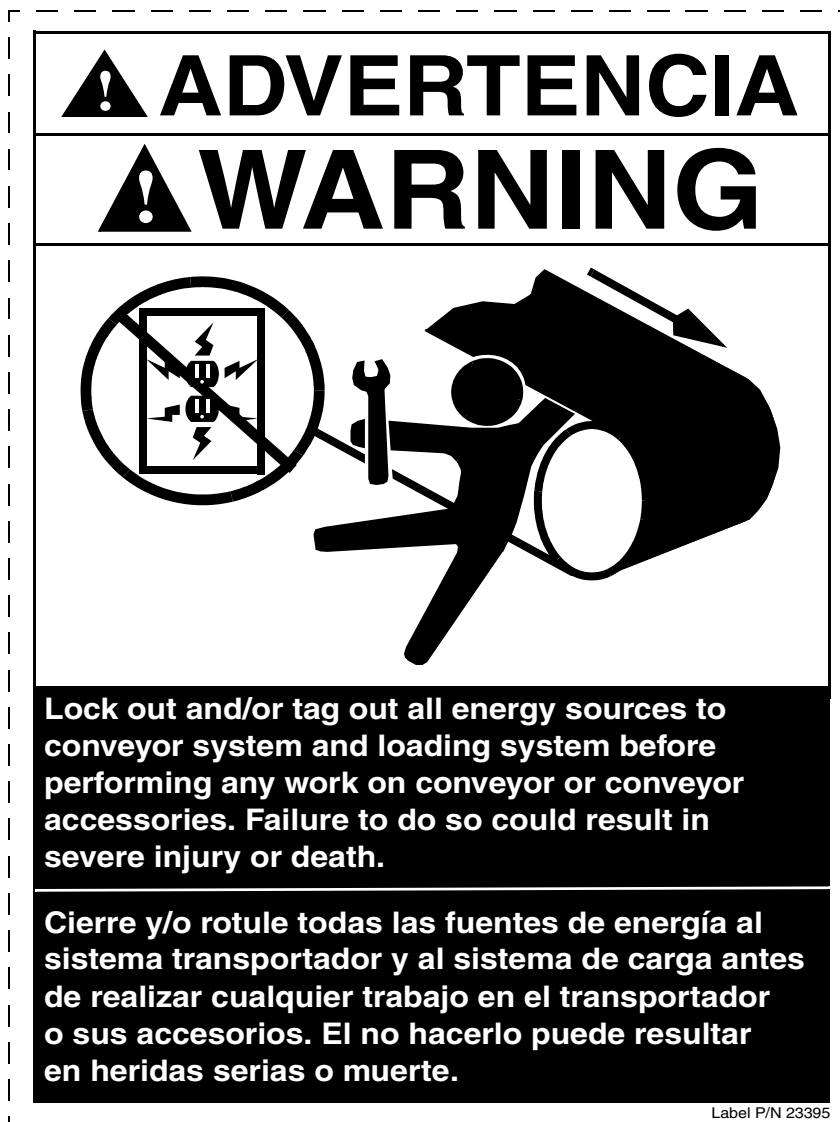

Figure 13. Conveyor Products Warning Label, P/N 23395



Figure 14. Pinch Point Warning Label, P/N 30528

Any product, process, or technology described here may be the subject of intellectual property rights reserved by Martin Engineering Company. Trademarks or service marks designated with the ® symbol are registered with the U.S. Patent and Trademark Office and may be proprietary in one or more countries or regions. Other trademarks and service marks belonging to Martin Engineering Company in the United States and/or other countries or regions may be designated with the “TM” and “SM” symbols. Brands, trademarks, and names of other parties, who may or may not be affiliated with, connected to, or endorsed by Martin Engineering Company, are identified wherever possible. Additional information regarding Martin Engineering Company’s intellectual property can be obtained at www.martin-eng.com/trademarks.

Problem Solved™ GUARANTEED!

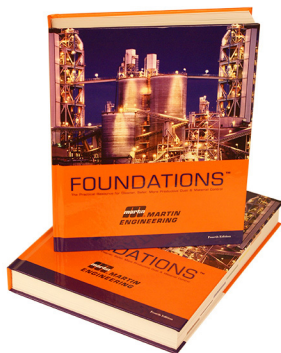

For nearly 20 years, Martin Engineering's Foundations™ Books have taught industry personnel to operate and maintain clean and safe belt conveyors. The Foundations™ Book, fourth edition, focuses on improving belt conveyors by controlling fugitive material. "The Practical Resource for Total Dust and Material Control," is a 576-page hard cover volume that provides information of value to industries where the efficient handling of bulk materials is a key to productivity and profitability.

Expanding upon the book, our Foundations™ Training Program addresses the design and development of more productive belt conveyors, and is offered in three customizable seminars. Attendees gain a better understanding of conveyor safety and performance, helping to justify upgrade investments and increase profitability.



Martin Engineering Australia Pty Ltd.
20 Ern Harley Dr - Burleigh Heads, QLD, 4220 - Australia
1300 627 364
www.martin-eng.com.au

