

Martin® QC1+™ Cleaner HD Three-Piece Mainframe



The [Martin® QC1+™ Cleaner HD](#) introduces the next generation of belt cleaning technology.

A truly revolutionary innovation in belt cleaning design, the QC1+™ Cleaner HD provides the cleanest belt and longest blade life— at the lowest cost.

FEATURES & BENEFITS

- Same ease of installation as original Martin® QC1™ Cleaners, maintaining standard installation and service costs.
- Utilizes Martin's highly effective, patented CARP profile, ensuring the highest level of cleaning performance expected from a Martin® Belt Cleaner.

MOUNTING LOCATION

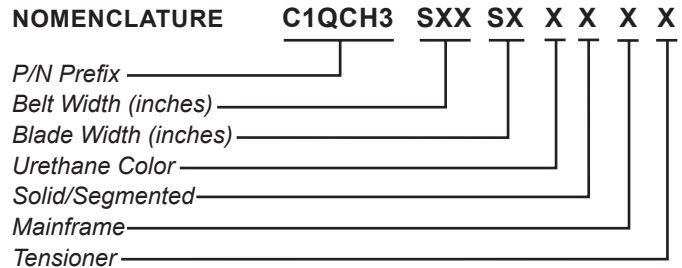
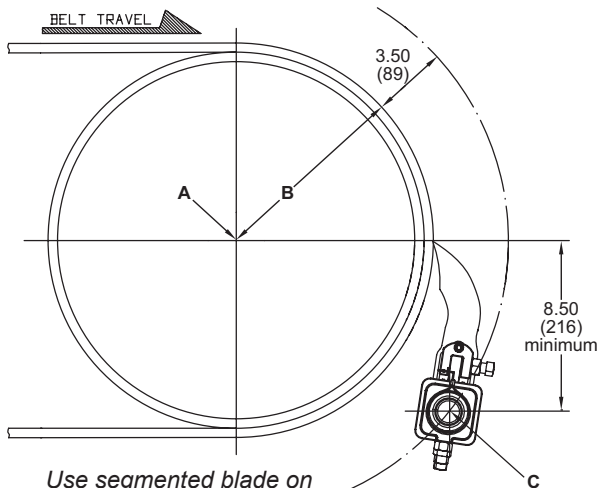

BELT WIDTH

SXX: XX indicates belt width in inches (18 thru 96)

SA2: 102 Inches

SA8: 108 Inches

BLADE WIDTH

00: No Blade

S4: 4 Inches less Belt Width

S6: 6 Inches less Belt Width

S8: 8 Inches less Belt Width

URETHANE COLOR

0: No Blade

B: Brown

T: Tan

G: Green

N: Navy Blue

O: Orange

C: Yellow with Ceramic Beads

SOLID/SEGMENTED

0: Segmented Blade/No Blade

1: Solid Blade

MAINFRAME

E: Painted Steel with Extended Torque Tubes and Aluminum Blade Insert

F: Stainless Steel with Steel Blade Insert

P: Painted Steel with Aluminum Blade Insert

T: Painted Steel with Steel Blade Insert

Z: Stainless Steel with Extended Torque Tubes and Steel Blade Insert

TENSIONER

O: Martin® Twist Tensioner (P/N 31443)

F: Martin® Twist Tensioner Stainless Steel (P/N 31443-SS)

T: Martin® Twist Tensioner (P/N 38850)

S: Martin® Spring Tensioner (P/N 38180)

P: Martin® Spring Tensioner Stainless Steel (P/N 38180-SS)

SPECIFICATIONS

Maximum Belt Speed fpm (m/sec)	Maximum Service Temperature	Pulley Diameter** in. (mm)	Mounting Location in. (mm)	Wear Life* in. (mm)	Wear Volume (per inch of blade) in ³ (cm ³)
900 (4.6)	160°F (70°C) Continuous 180°F (82°C) Intermittent	16–22 (406–559)	3.5 (89)	4.5 (114)	6.53 (107)

* Amount of usable blade

** Pulley diameter 23 in. (584 mm) and greater: contact your Martin Engineering representative.

High-performance urethanes are available; see your Martin Engineering representative for assistance in specifying non-standard products. Refer to Form No. L3375.

TECHNICAL DATA SHEET

DIMENSIONS -- in. (mm)

Belt Width in. (mm)	Mainframe Length (B) in. (mm)
18 (400-500)	34 (864)
24 (500-650)	46 (1168)
30 (650-800)	52 (1321)
36 (800-1000)	60 (1524)
42 (1000-1200)	72 (1829)
48 (1200-1400)	78 (1981)
54 (1400-1600)	84 (2134)
60 (1600-1700)	90 (2286)

Belt Width in. (mm)	Mainframe Length (B) in. (mm)
66 (1700-1800)	96 (2438)
72 (1800-2000)	102 (2591)
78 (1800-2000)	108 (2743)
84 (2000-2100)	114 (2896)
90 (2100-2200)	120 (3048)
96 (2200-2400)	126 (3200)
102 (2400-2600)	132 (3354)
108 (2600-2800)	138 (3505)

Note: Dimension A equals belt width minus either 4,6, or 8 inches.

Dual Tensioners are required for belt widths 54 in. (1400 mm) and greater.

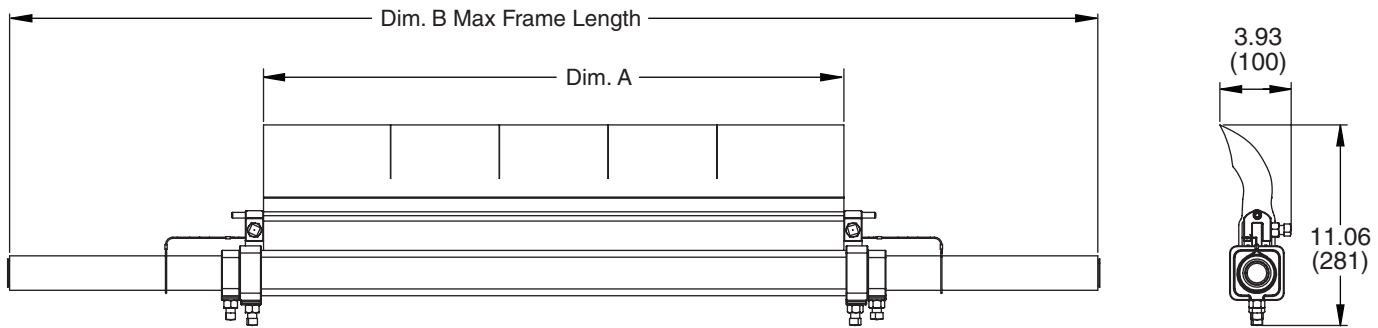

RECOMMENDED TENSIONERS

Tensioner	P/N
Martin® Twist Tensioner	38850
Martin® Spring Tensioner	38180

ACCESSORIES

Part	P/N
Martin® Steel Inspection Door	CYA-1218
Martin® Hanger Mount Standard Assembly	27382

REPLACEMENT BLADE NOMENCLATURE

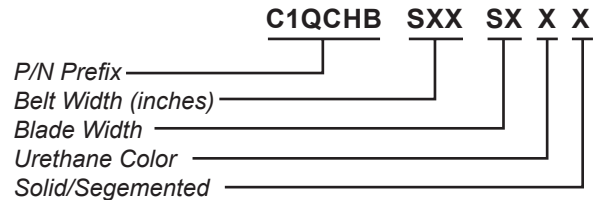

BELT WIDTH

SXX: XX indicates belt width in inches (18 thru 96)

SA2: 102 Inches

SA8: 108 Inches

URETHANE COLOR

B: Brown

T: Tan

G: Green

N: Navy Blue

O: Orange

C: Yellow with Ceramic Beads

BLADE WIDTH

S4: 4 Inches less Belt Width

S6: 6 Inches less Belt Width

S8: 8 Inches less Belt Width

SOLID/SEGMENTED

0: Segmented without Slots

1: Solid without Slots

2: Segmented with Slots

3: Solid with Slots

4: Segmented without Slots & with Blade Clamp Kit

5: Solid without Slots & with Blade Clamp Kit

FREQUENTLY ASKED QUESTIONS

My Pre-Cleaner keeps flipping through.

The mounting location may be too far away from the belt. Relocate to the proper dimension.

Replace the mainframe or end weldments if they are bent.

My Pre-Cleaner is wearing more in the center of the blade.

The blade is too wide for this application. Replace with a shorter length blade.



Martin Engineering Australia Pty Ltd.

20 Ern Harley Dr - Burleigh Heads, QLD, 4220 - Australia

1300 627 364

www.martin-eng.com.au

