

martin®

Martin®
Idler Conversion Kit



Operator's Manual
M3623

Important

MARTIN ENGINEERING HEREBY DISCLAIMS ANY LIABILITY FOR: DAMAGE DUE TO CONTAMINATION OF THE MATERIAL; USER'S FAILURE TO INSPECT, MAINTAIN AND TAKE REASONABLE CARE OF THE EQUIPMENT; INJURIES OR DAMAGE RESULTING FROM USE OR APPLICATION OF THIS PRODUCT CONTRARY TO INSTRUCTIONS AND SPECIFICATIONS CONTAINED HEREIN. MARTIN ENGINEERING'S LIABILITY SHALL BE LIMITED TO REPAIR OR REPLACEMENT OF EQUIPMENT SHOWN TO BE DEFECTIVE.

Observe all safety rules given herein along with owner and Government standards and regulations. Know and understand lockout/tagout procedures as defined by American National Standards Institute (ANSI) z244.1-1982, *American National Standard for Personnel Protection - Lockout/Tagout of Energy Sources - Minimum Safety Requirements* and Occupational Safety and Health Administration (OSHA) Federal Register, Part IV, 29 CFR Part 1910, *Control of Hazardous Energy Source (Lockout/Tagout); Final Rule*.

The following symbols may be used in this manual:



Danger: Immediate hazards that will result in severe personal injury or death.



Warning: Hazards or unsafe practices that could result in personal injury.



Caution: Hazards or unsafe practices that could result in product or property damages.



Important: Instructions that must be followed to ensure proper installation/operation of equipment.



Note: General statements to assist the reader.

Table of Contents

Section	Page
List of Figures	ii
List of Tables	ii
Introduction	1
General	1
References	1
Safety	1
Materials required	1
Before Installing Idler Conversion Kit	2
Installing Idler Conversion Kit	3
After Installing Idler Conversion Kit	6
Weekly Maintenance	7
Part Numbers	8

List of Figures

Figure	Title	Page
1	Completed Idler Conversion	5
2a	Martin® Idler Conversion Kit Assembly, P/N 37135-KXX	8
2b	Martin® Idler Conversion Kit Assembly, P/N 37135-KXX Parts List	9
3a	Martin® Idler Slider Bar Assembly, P/N 37135-BXX	10
3b	Martin® Idler Slider Bar Assembly, P/N 37135-BXX Parts List	10
4	Placement of Belt Travel Label, P/N 37171	11
5	Conveyor Products Warning Label, P/N 23395	12

List of Tables

Table	Title	Page
I	Martin® Idler Conversion Kit Part Numbers and Dimensions	9
II	Conversion Slider Bar Assembly Dimensions and Part Numbers	11
III	Martin® Slider Bar Specifications	11

Introduction

General

The Martin® Idler Conversion Kit improves the conveyor belt support system by stabilizing the belt line, improving the sealing and preventing spillage. The Martin® Idler Conversion Kit links two or more troughing idler frames replacing the wing rollers with Martin® Slider Bars.

References

The following documents are referenced in this manual:

- American National Standards Institute (ANSI) z244.1-1982, *American National Standard for Personnel Protection - Lockout/Tagout of Energy Sources - Minimum Safety Requirements*, American National Standards Institute, Inc., 1430 Broadway, New York, NY 10018.
- Federal Register, Volume 54, Number 169, Part IV, 29 CFR Part 1910, *Control of Hazardous Energy Source (Lockout/Tagout); Final Rule*, Department of Labor, Occupational Safety and Health Administration (OSHA), 32nd Floor, Room 3244, 230 South Dearborn Street, Chicago, IL 60604.

Safety

All safety rules defined in the above documents and all owner/employer safety rules must be strictly followed when working on the Martin® Belt Support System.

Materials required

In addition to standard hand tools, a 5-ft (1.5-m) angle is needed to install this equipment.

Before Installing Idler Conversion Kit

IMPORTANT

The delivery service is responsible for damage occurring in transit. Martin Engineering CANNOT enter claims for damages. Contact your transportation agent for more information.

1. Inspect shipping container for damage. Report damage to delivery service immediately and fill out delivery service's claim form. Keep any damaged goods subject to examination.
2. Remove Martin® Idler Conversion Kit from shipping container. Equipment in container should include the following:
 - Martin® Idler Conversion Kit Single Bar or Double Bar Cradle Assembly. Refer to Figure 2a for Assembly Drawing.
 - Two Conveyor Products Warning Labels, P/N 23395.
3. If anything is missing, contact Martin Engineering or representative.

WARNING

Before installing equipment, turn off and lock out/tag out energy source to conveyor and conveyor accessories.



4. Turn off and lock out/tag out energy source according to ANSI standards (see "References").

WARNING

If equipment will be installed in an enclosed area, gas level or dust content must be tested before using a cutting torch or welding. Using a cutting torch or welding in an area with gas or dust may cause an explosion.



5. If using a cutting torch or welding, test atmosphere for gas level or dust content. Cover conveyor belt with fire retardant cover.

Installing Idler Conversion Kit

IMPORTANT

Read entire section before beginning work.

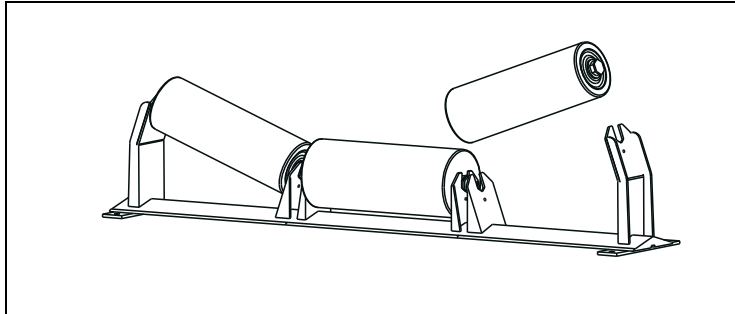

1. Remove Wing Rolls.

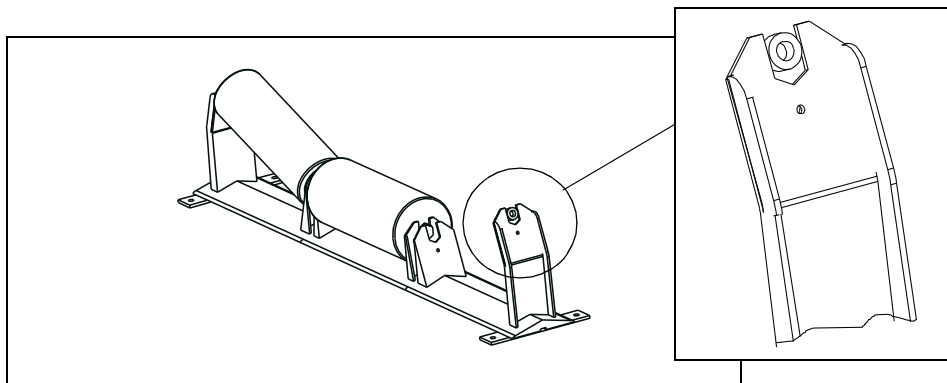

2. Match bushing to slot width.

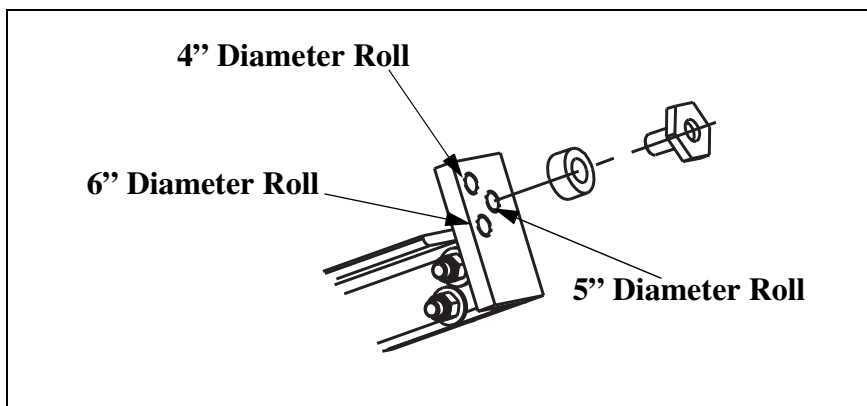

3. Choose proper belt location based on roll diameter

Installation

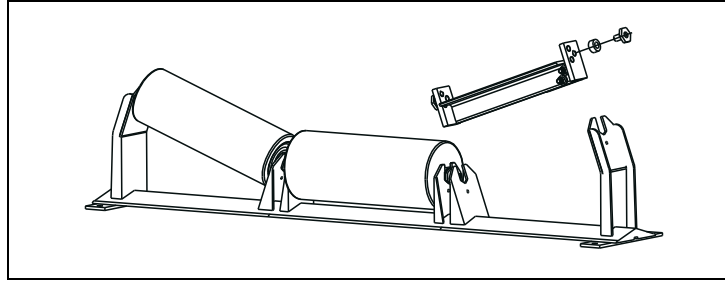

4. Assemble hex nut and bushing bracket. Apply LOCTITE[®] Adhesive to threads.

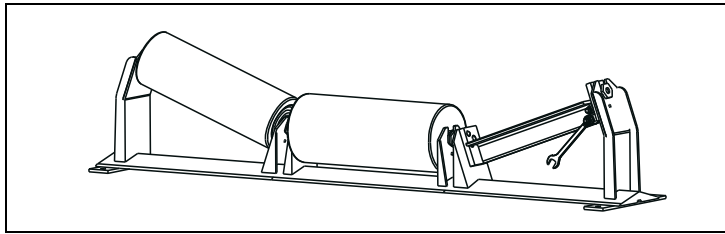

5. Assemble bracket to frame and tighten locking bolts (approx. 25 ft-lbs).

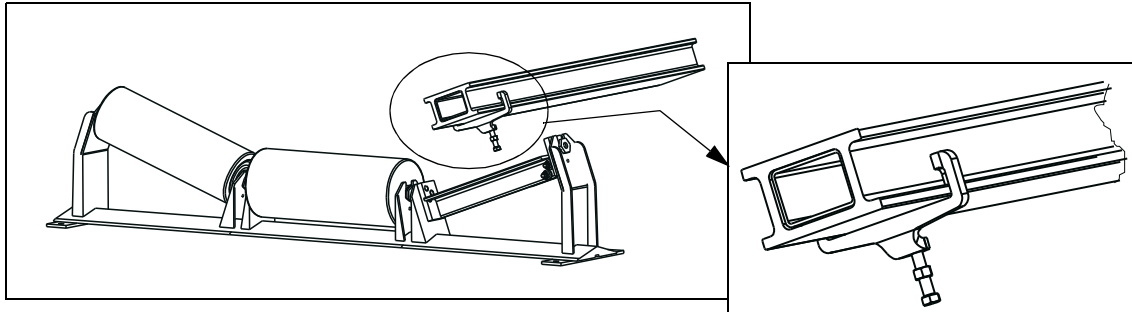

6. Slide clamp over ends of the Martin[®] Slider Bar and place in position. Repeat for all idlers.

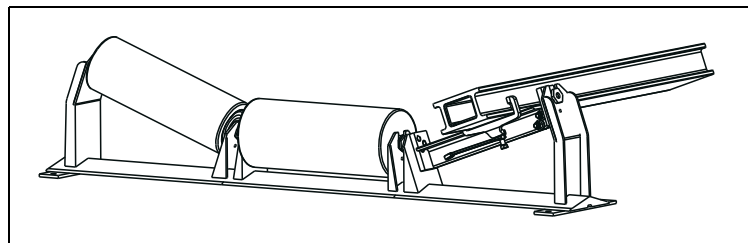

7. Locate bar under chute wall and slide clamp over end of bracket and tighten. Set screw until the clamp begins to deform the Martin[®] Slider Bar (approx. 10 ft-lbs). Tighten the jam nut against the clamp.

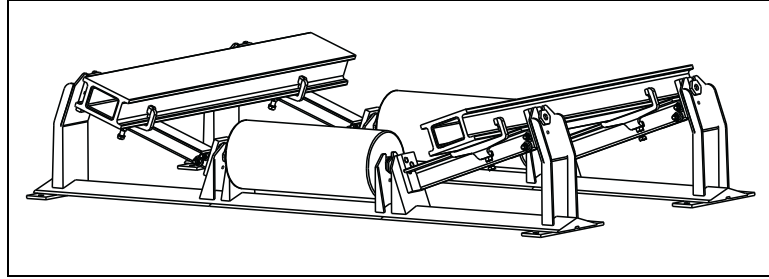

8. Repeat for all idlers to be converted.

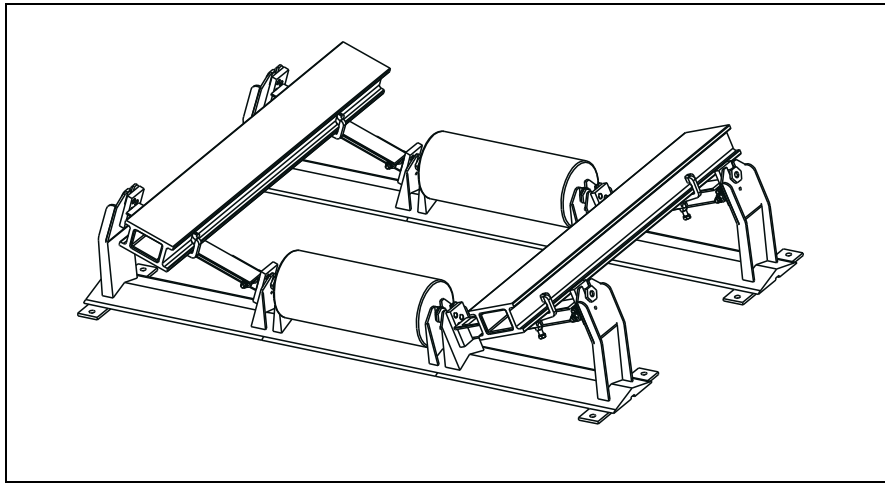

Figure 1. Completed Idler Conversion

After Installing Idler Conversion Kit

IMPORTANT

Read entire section before beginning work.

1. Thoroughly wipe outside chute walls clean above Slider Cradle on both sides of chute. Place a Conveyor Products Warning Label (P/N 23395) on each chute wall visible to belt operator.

WARNING

Failure to remove tools from installation area and conveyor belt before turning on energy source can cause serious injury to personnel and damage to belt.

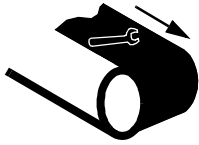

2. Remove all tools and fire retardant cover from installation area and conveyor belt.

DANGER

Do not touch or go near conveyor belt or conveyor accessories when conveyor belt is running. Body or clothing can get caught and pull body into conveyor belt, causing severe injury or death.



3. Turn on conveyor belt for one hour.

WARNING

Before adjusting Martin® Idler Conversion Kit, turn off and lock out/tag out energy source to conveyor belt and conveyor accessories.



4. After one hour of operation, turn off and lock out/tag out energy source according to ANSI standards (see “References”). Check bolts for tightness.

Weekly Maintenance

IMPORTANT

Read entire section before beginning work.



Inspecting for Wear

WARNING

Before servicing Slider Cradle, turn off and lock out/tag out energy source to conveyor belt and conveyor accessories.

1. Turn off and lock out/tag out energy source according to ANSI standards (see “References”).
2. Make sure all fasteners are tight. Tighten if necessary.
3. Check slider bars for wear. If worn more than 1/4”, replace.

WARNING

Failure to remove tools from installation area and conveyor belt before turning on energy source can cause serious injury to personnel and damage to belt.

4. Remove all tools from maintenance area.

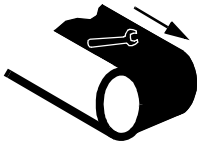

DANGER

Do not touch or go near conveyor belt or conveyor accessories when conveyor belt is running. Body or clothing can get caught and pull body into conveyor belt, causing severe injury or death.

5. Start conveyor belt.



Part Numbers

This section provides product names and corresponding part numbers for Martin® Idler Conversion Kit and related equipment. Please reference part numbers when ordering parts.

Martin® Idler Conversion Kit

Martin® Idler Conversion Kit Assembly: P/N 37135-KXX.
Refer to Figures 2a and 2b.

Slider Bars

Martin® Idler Slider Bar Assembly: P/N 37135-BXX.
Refer to Figures 3a and 3b.

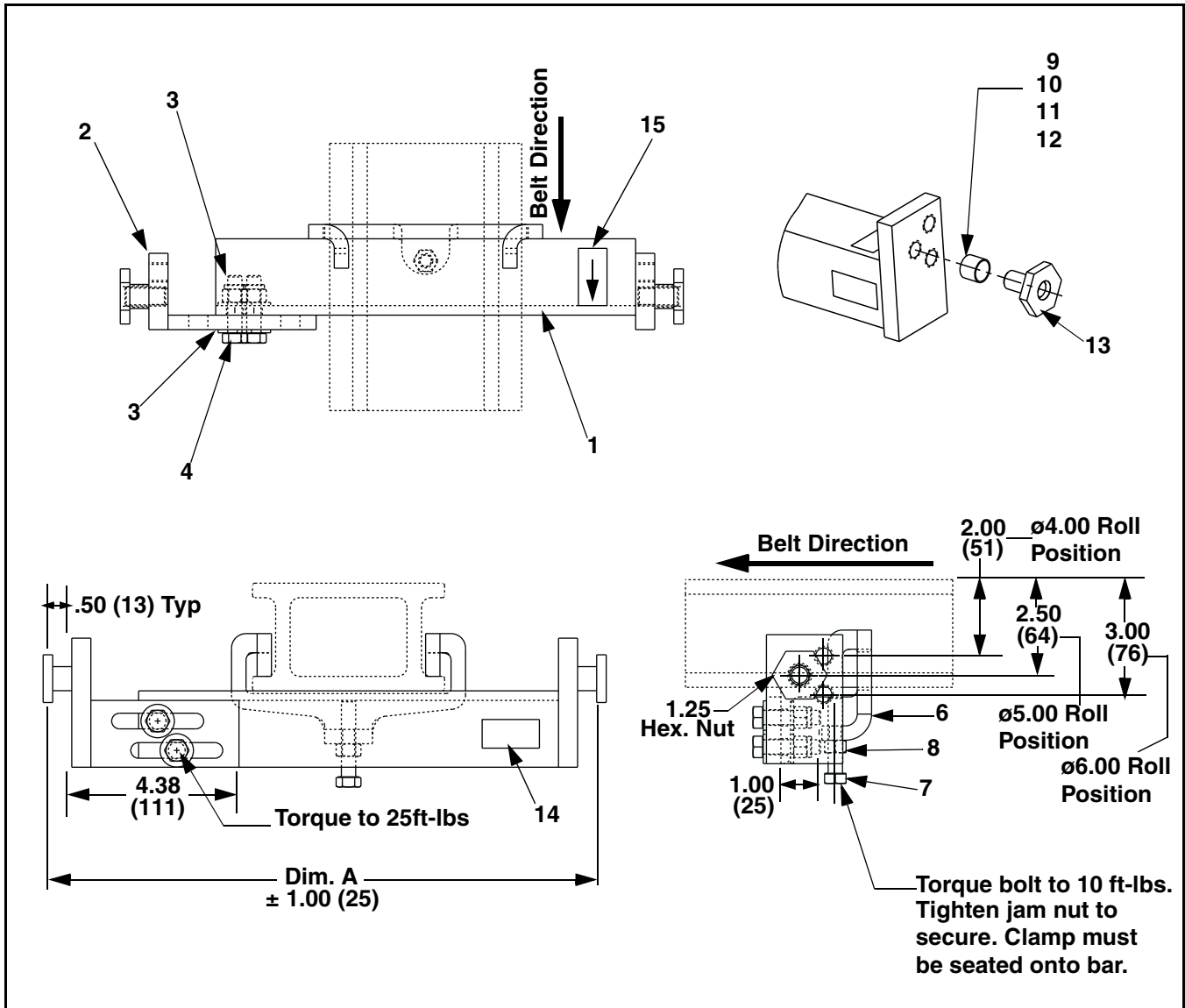

Figure 2a. Martin® Idler Conversion Kit Assembly P/N 37135-KXX

Item	Description	Part No.	Qty
1	Angle Weldment	Table I	2
2	Adjustable End Weldment	37178	2
3	Washer Flat 5/16 Wide ZP	13847	8
4	Screw HHC 3/8 - 16NC x 1 - 1/2 ZP	32719	4
5	Nut Hex Elastic Lock 3/8 - 16 NC ZP	14201	4
6	Bar Clamp Bracket	37176	See Table I
7	Screw HHC 3/8 - 16NC x 2 ZP	37036	See Table I
8	Nut Hex 3/8 - 16NC x ZP	11770	See Table I
9	.63 Bushing	37184-63	4
10	.75 Bushing	37184-75	4
11	.94 Bushing	37184-94	4
12	1.06 Bushing	37184-106	4
13	Hex End Weldment	37183	4
14	Martin Products Label	32238	2
15	Belt Travel Label	37171	2
16	Conveyor Products Warning Label	23395	2
17	LOCTITE® Adhesive Capsule	35433	2
18	Operator Manual	M3623	1
19	Bushing ø.75 Modified	37184-75M	4
20	Screw HHC 1/2-13NC x 1 ZP		

Figure 2b. Martin® Idler Conversion Kit Assembly, P/N 37135-KXX Parts List

Table I. Martin® Idler Conversion Kit Part Numbers and Dimensions

Part No.	Dim. A ± 1.00	Part No. Item 1	Qty. of Items 6, 7, and 8
37135-K18	8.25 (210)	37177-18	2
37135-K24	10.25 (260)	37177-24	2
37135-K30	12.25 (311)	37177-30	2
37135-K36	14.25 (362)	37177-36	2
37135-K42	16.25 (413)	37177-42	2
37135-K48	18.25 (464)	37177-48	4
37135-K54	20.75 (527)	37177-54	4
37135-K60	22.75 (578)	37177-60	4
37135-K72	26.75 (679)	37177-72	4
37135-K84	31.00 (787)	37177-84	4
37135-K96	35.00 (889)	37177-96	4

See Figures 2a and 2b

Notes:

1. All dimensions are given in inches (mm).
2. All dimensions are for reference only.
3. Slider bar shown for reference only. See drawing 37135-BXX for slider bar kit (Figures 3a and 3b).
4. Bushings are provided to adapt to most idler roller end configurations. Select appropriate bushing from the provided and install hex end weldment in correct mounting hole location according to roller can diameter.
5. Apply LOCTITE® Adhesive to threads of hex weldment before installation.
6. Kit must be installed with belt travel direction as shown. Failure to install correctly could result in bar clamp failure. Refer to Figure 4.
7. Kit includes enough parts to convert both wing rollers on (1) troughing or impact idler.

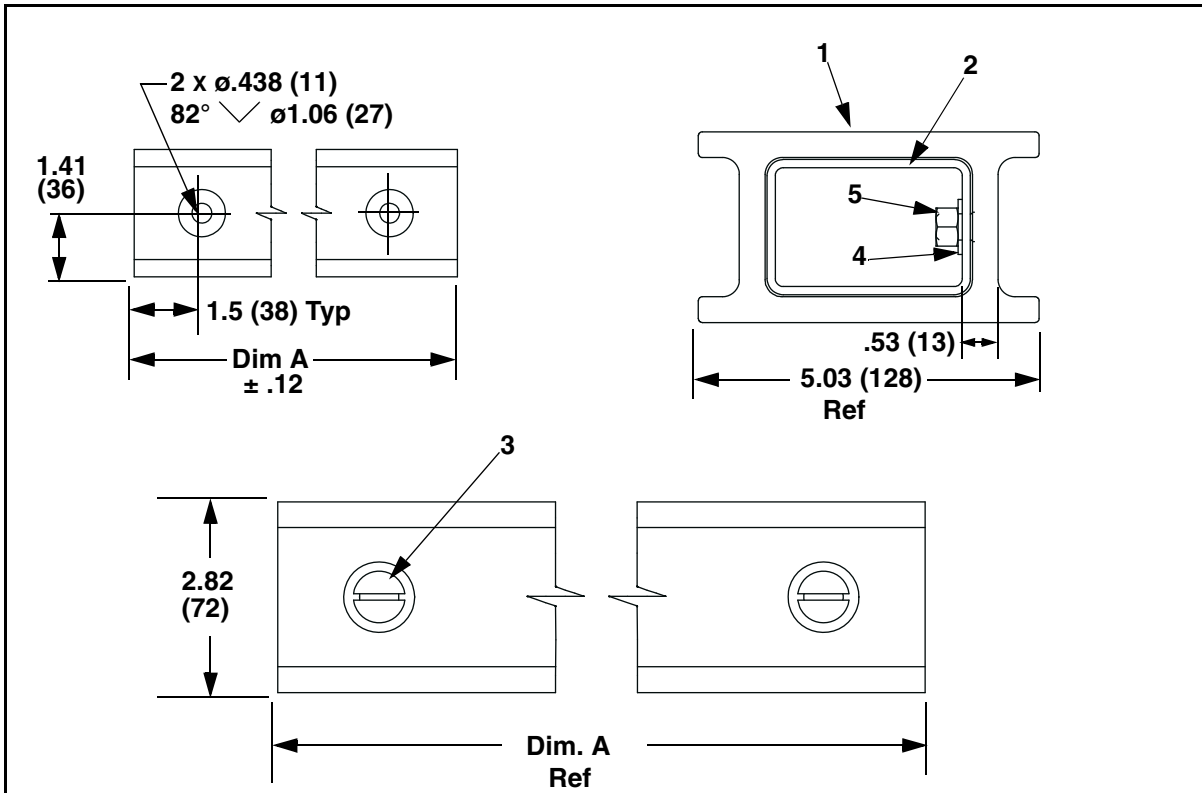

Figure 3a. Martin® Idler Slider Bar Assembly, P/N 37135-BXX

Item	Description	Part No.	Qty
1	Slider Bar Extrusion	100407	Table II
2	Slider Bar	Table II	1
3	Screw FSCSH 3/8-16NC x 3/4 ZP	32900	2
4	Washer Compression 3/8	11747	2
5	Nut Hex 3/8 - 16 NC ZP	11770	2

Figure 3b. Martin® Idler Conversion Slider Bar Assembly Parts List, P/N 37135-BXX

Table II. Conversion Slider Bar Assembly Dimensions and Part Numbers

Part No.	Dim. A Qty. Item 1	Part No. Item 2
37135-B24	24 (610)	37172-24
37135-B36	36 (914)	37172-36
37135-B48	48 (1219)	37172-48
37135-B60	60 (1524)	37172-60
37135-B72	72 (1829)	37172-72
37135-B84	84 (2134)	37172-84
37135-B96	96 (2438)	37172-96
37135-B108	108 (2743)	37172-108
37135-B120	120 (3048)	37172-120
37135-B132	132 (3353)	37172-132
37135-B144	144 (3658)	37172-144

See Figures 3a and 3b

Notes: All dimensions are given in inches. All inch dimensions are $\pm .06$ unless otherwise specified. (MM) values and tolerances should be derived from inch values given.

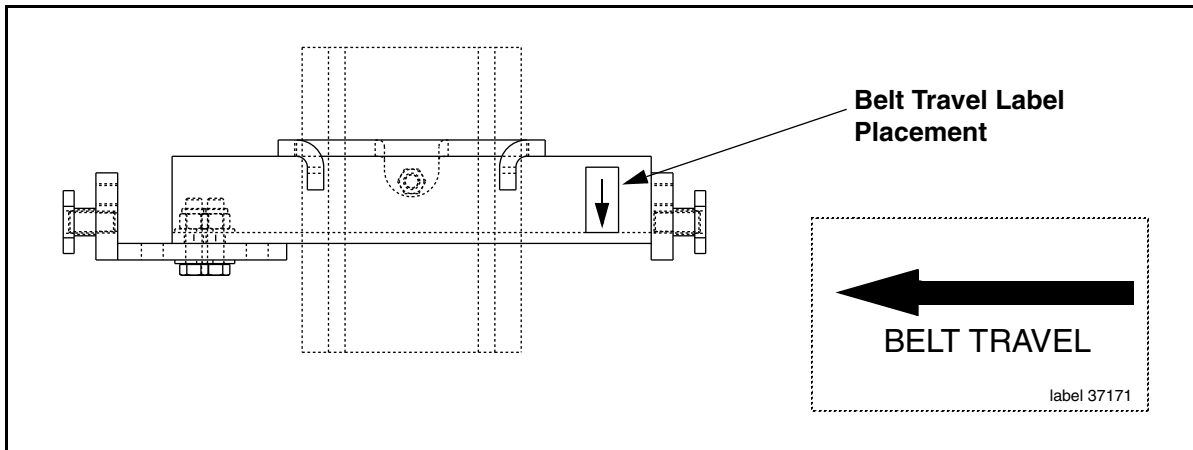

Figure 4. Placement of Belt Travel Label, P/N 37171

Table III. Martin® Slider Bar Specifications

Bar construction	UHMW polyethylene
Bar dimensions	2.9 in. (72 mm) high 5.0 in. (127 mm) wide 48 in. (1220 mm) long
Coefficient of friction	0.5
Specific gravity	0.94
Tensile strength	6800 lb at 73°F (23°C)
Hardness	62 (Shore D)
Service temperature	-20 to 140°F (-29 to 60°C)

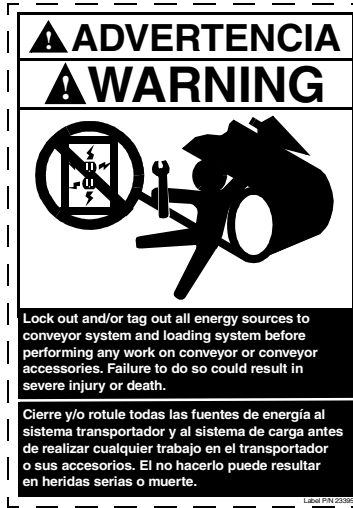
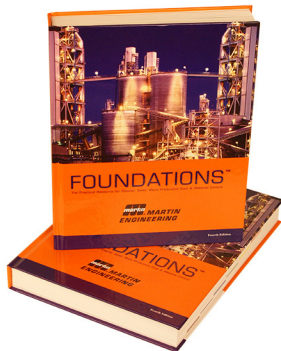

Figure 5. Conveyor Products Warning Label, P/N 23395

Any product, process, or technology described here may be the subject of intellectual property rights reserved by Martin Engineering Company. Trademarks or service marks designated with the ® symbol are registered with the U.S. Patent and Trademark Office and may be proprietary in one or more countries or regions. Other trademarks and service marks belonging to Martin Engineering Company in the United States and/or other countries or regions may be designated with the “TM” and “SM” symbols. Brands, trademarks, and names of other parties, who may or may not be affiliated with, connected to, or endorsed by Martin Engineering Company, are identified wherever possible. Additional information regarding Martin Engineering Company’s intellectual property can be obtained at www.martin-eng.com/trademarks.

Problem Solved™ GUARANTEED!



For nearly 20 years, Martin Engineering's Foundations™ Books have taught industry personnel to operate and maintain clean and safe belt conveyors. The Foundations™ Book, fourth edition, focuses on improving belt conveyors by controlling fugitive material. "The Practical Resource for Total Dust and Material Control," is a 576-page hard cover volume that provides information of value to industries where the efficient handling of bulk materials is a key to productivity and profitability.

Expanding upon the book, our Foundations™ Training Program addresses the design and development of more productive belt conveyors, and is offered in three customizable seminars. Attendees gain a better understanding of conveyor safety and performance, helping to justify upgrade investments and increase profitability.



Martin Engineering Australia Pty Ltd.
20 Ern Harley Dr - Burleigh Heads, QLD, 4220 - Australia
1300 627 364
www.martin-eng.com.au

