

***martin***®

***Martin***®  
***Diagonal Plow***



***Operator's Manual***  
***M3239***

# Important

MARTIN ENGINEERING HEREBY DISCLAIMS ANY LIABILITY FOR: DAMAGE DUE TO CONTAMINATION OF THE MATERIAL; USER'S FAILURE TO INSPECT, MAINTAIN AND TAKE REASONABLE CARE OF THE EQUIPMENT; INJURIES OR DAMAGE RESULTING FROM USE OR APPLICATION OF THIS PRODUCT CONTRARY TO INSTRUCTIONS AND SPECIFICATIONS CONTAINED HEREIN. MARTIN ENGINEERING'S LIABILITY SHALL BE LIMITED TO REPAIR OR REPLACEMENT OF EQUIPMENT SHOWN TO BE DEFECTIVE.

Observe all safety rules given herein along with owner and Government standards and regulations. Know and understand lockout/tagout procedures as defined by American National Standards Institute (ANSI) z244.1-1982, *American National Standard for Personnel Protection - Lockout/Tagout of Energy Sources - Minimum Safety Requirements* and Occupational Safety and Health Administration (OSHA) Federal Register, Part IV, 29 CFR Part 1910, *Control of Hazardous Energy Source (Lockout/Tagout); Final Rule*.

The following symbols may be used in this manual:



**Danger:** Immediate hazards that will result in severe personal injury or death.



**Warning:** Hazards or unsafe practices that could result in personal injury.



**Caution:** Hazards or unsafe practices that could result in product or property damages.



**Important:** Instructions that must be followed to ensure proper installation/operation of equipment.



**Note:** General statements to assist the reader.

# Table of Contents

---

<b>Section</b>	<b>Page</b>
List of Figures/Tables .....	ii
Introduction .....	1
General .....	1
References .....	1
Safety .....	1
Materials required .....	1
Before Installing Plow .....	2
Installing Plow .....	3
Installing mounting brackets .....	3
Installing plow onto mounting brackets .....	6
Installing restraining cable .....	6
After Installing Plow .....	7
Weekly Maintenance .....	8
Troubleshooting/Installation Checklist .....	10
Part Numbers .....	11

## **List of Figures**

---

<b>Figure</b>	<b>Title</b>	<b>Page</b>
1	Locating Plow on Belt .....	3
2	Locating Mounting Brackets on Stringers .....	4
3	Installing Martin <sup>®</sup> Diagonal Plow Assembly .....	5
4	Installing Restraining Cable .....	6
5	Martin <sup>®</sup> Diagonal Plow Assembly, P/N 22662-XXX .....	11
6	Conveyor Products Warning Label, P/N 23395 .....	13
7	Flying Objects Warning Label, P/N 38227.....	14

## **List of Tables**

---

<b>Table</b>	<b>Title</b>	<b>Page</b>
I	Locating Mounting Brackets on Stringers .....	4
II	Martin <sup>®</sup> Diagonal Plow Assembly Part Quantities.....	12
III	Martin <sup>®</sup> Diagonal Plow Blade Part Numbers.....	12

# Introduction

---

## ***General***

The Martin® Diagonal Plow protects pulleys from material carryback on single-direction and reversing conveyor belts. Hung from brackets at a 45° angle across the belt, the Martin® Diagonal Plow rides on the conveyor belt and removes material without requiring adjustment. A restraining cable prevents the plow from being carried into the pulley should its mounting brackets come loose.

The Martin® Diagonal Plow is equipped with a replaceable rubber or urethane cleaning blade and is available in sizes to fit belts from 18 to 120 in. (400 to 3000 mm) wide.

## ***References***

The following documents are referenced in this manual:

- American National Standards Institute (ANSI) z244.1-1982, *American National Standard for Personnel Protection - Lockout/Tagout of Energy Sources - Minimum Safety Requirements*, American National Standards Institute, Inc., 1430 Broadway, New York, NY 10018.
- Federal Register, Volume 54, Number 169, Part IV, 29 CFR Part 1910, *Control of Hazardous Energy Source (Lockout/Tagout); Final Rule*, Department of Labor, Occupational Safety and Health Administration (OSHA), 32nd Floor, Room 3244, 230 South Dearborn Street, Chicago, IL 60604.

## ***Safety***

All safety rules defined in the above documents and all owner/employer safety rules must be strictly followed when working on this equipment.

## ***Materials required***

Only standard hand tools are required to install and service this equipment.

# Before Installing Plow

---

## IMPORTANT

The delivery service is responsible for damage occurring in transit. Martin Engineering CANNOT enter claims for damages. Contact your transportation agent for more information.

1. Inspect shipping container for damage. Report damage to delivery service immediately and fill out delivery service's claim form. Keep any damaged goods subject to examination.
2. Remove plow from shipping container. Equipment in container should include the following:
  - Martin® Diagonal Plow Assembly.
  - Two Conveyor Products Warning Labels, P/N 23395.
3. If anything is missing, contact Martin Engineering or a representative.

## WARNING

Before installing equipment, turn off and lock out/tag out energy source to conveyor and conveyor accessories.



4. Turn off and lock out/tag out energy source according to ANSI standards (see "References").

## WARNING

If equipment will be installed in an enclosed area, gas level or dust content must be tested before using a cutting torch or welding. Using a cutting torch or welding in an area with gas or dust may cause an explosion.

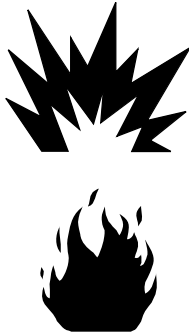

5. If using a cutting torch or welding, test atmosphere for gas level or dust content. Cover conveyor belt with fire retardant cover.

## IMPORTANT

Read entire section before beginning work.

To install the Martin® Diagonal Plow, follow the procedures corresponding to the following steps:

1. Install mount brackets on stringers.
2. Install plow onto mount brackets.
3. Install restraining cable.

### *Installing mounting brackets*

1. Locate plow on return side of conveyor belt before tail pulley where belt is taut or supported by idler. (See Figure 1.) (For determining location of belt in relation to conveyor stringer, see Figure 3.)

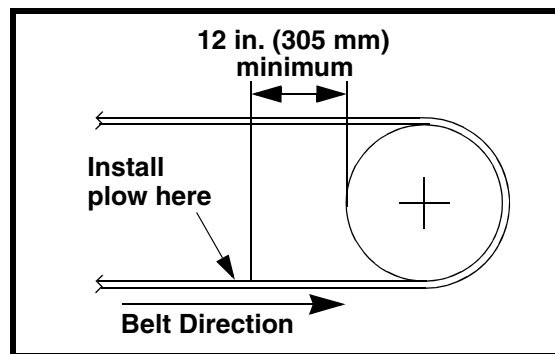

Figure 1. Locating Plow on Belt

## NOTE

Left side is determined by standing at tail pulley and looking toward head pulley.

2. Install mounting bracket (C, Figure 2) on left side of belt as follows:
  - a. Mark where you want to locate mounting bracket on left side of belt.
  - b. Center mounting bracket on mark, and weld to stringer.
  - c. Install adjustable guide (D) onto mounting bracket with two hex head cap screws, flat washers, and elastic lock nuts.
3. Locate mounting bracket on right side of belt as follows:
  - a. Starting from center of guide bushing (E) on left end adjustable guide, measure toward tail pulley the distance shown under “Dimension A” in Table I. Mark location on left side stringer.
  - b. Mark same location on right side stringer, directly across from mark on left side stringer.

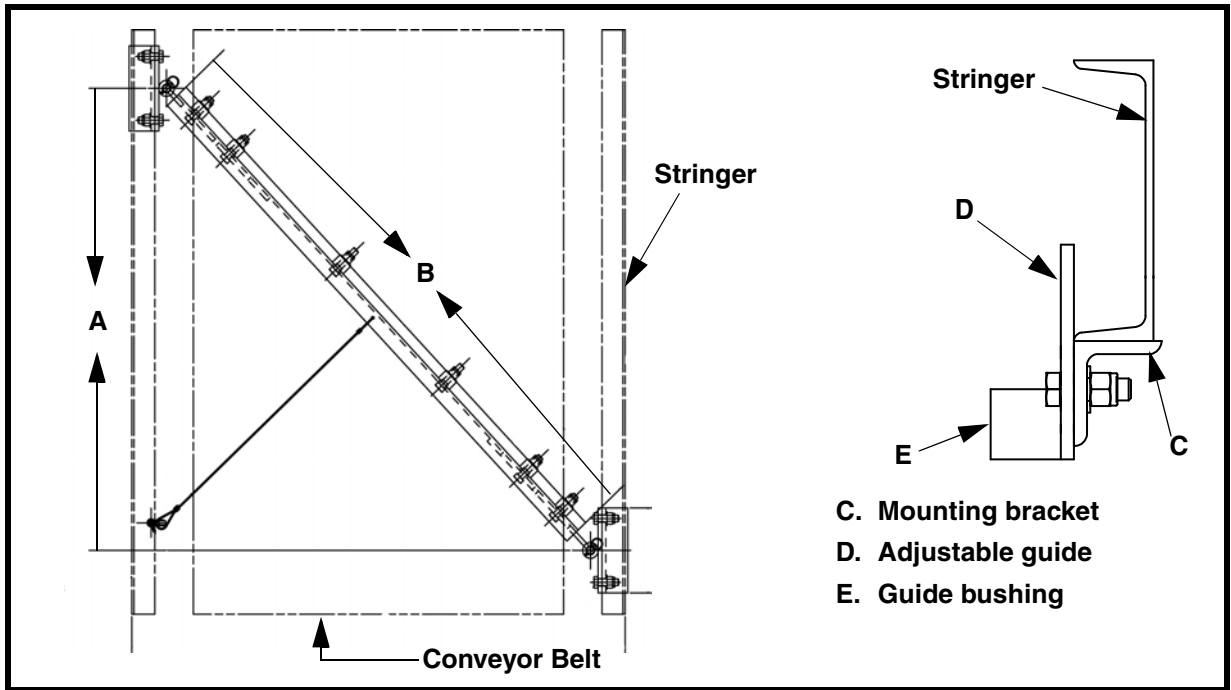

Figure 2. Locating Mounting Brackets on Stringers

Table I. Locating Mounting Brackets on Stringers

Belt Width in. (mm)	Dimension A	Dimension B
18 (400 - 500)	25.50 (648)	31.00 (787)
24 (500 - 650)	31.50 (800)	39.50 (1003)
30 (650 - 800)	37.50 (953)	48.00 (1219)
36 (800 - 1000)	43.50 (1105)	56.50 (1435)
42 (1000 - 1200)	49.50 (1257)	65.00 (1651)
48 (1200 - 1400)	55.50 (1410)	73.50 (1867)
54 (1400 - 1600)	61.50 (1562)	82.00 (2083)
60 (1600 - 1800)	67.50 (1715)	90.50 (2299)
66 (1600 - 1800)	73.50 (1867)	99.00 (2515)
72 (1800 - 2000)	79.50 (2019)	107.50 (2731)
84 (2000 - 2200)	91.50 (2324)	124.50 (3162)
96 (2200 - 2400)	105.50 (2680)	144.30 (3665)
120 (2600 - 2800)	129.50 (3289)	178.25 (4528)



4. Install mounting bracket on right side of belt as follows:
  - a. Loosely connect adjustable guide and right side mounting bracket with two hex head cap screws, flat washers, and elastic lock nuts.
  - b. Align hole in right side guide bushing with the mark on right side stringer.
  - c. Weld mounting bracket to right side stringer.
5. See Figure 3. Adjust each guide bracket so top of guide bushing is 5/8 in. (16 mm) above belt surface. (This will allow 1-1/2 in. [38 mm] of blade wear.)
6. Tighten hex head cap screws and elastic lock nuts on mounting brackets.

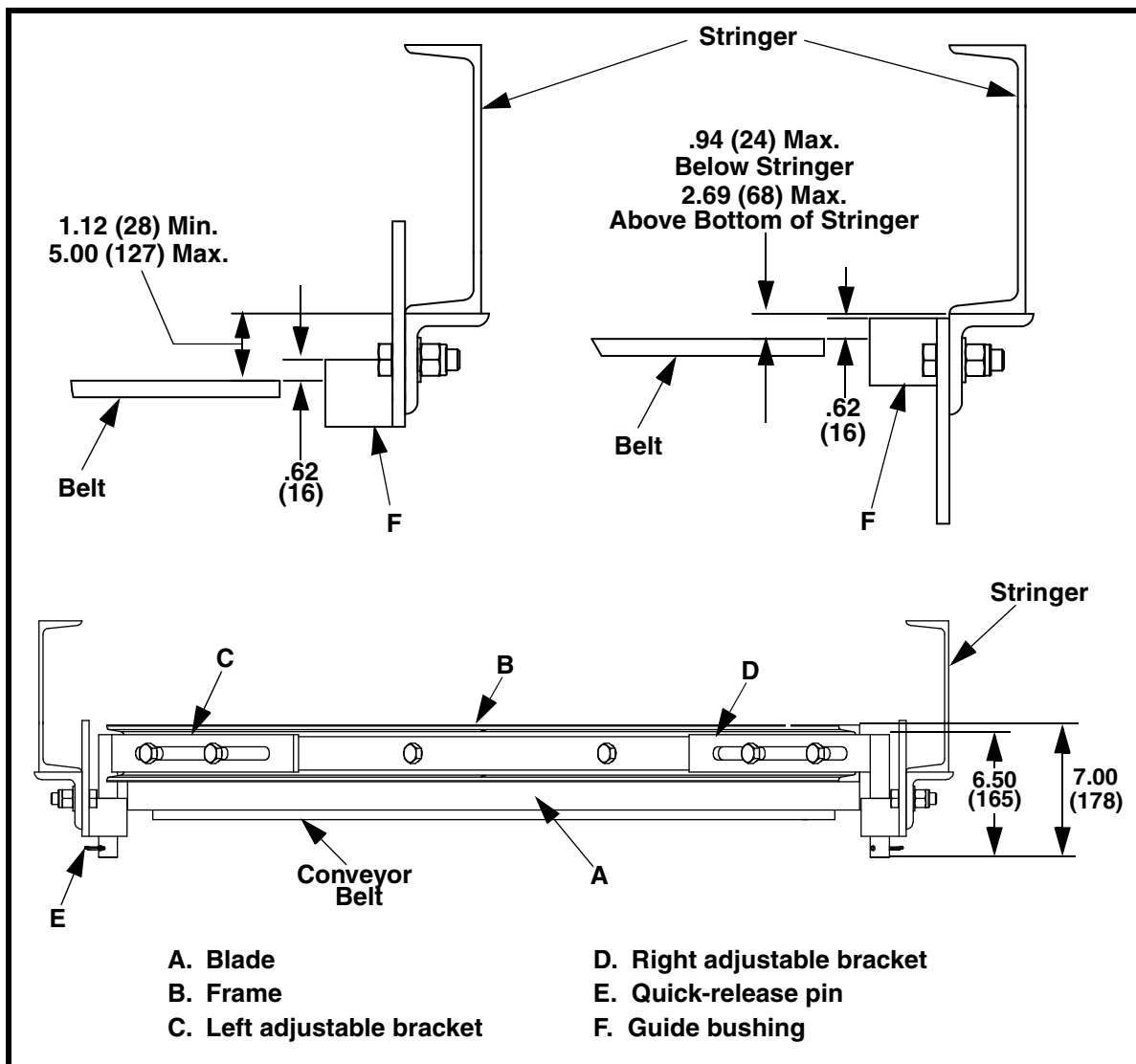

Figure 3. Installing Martin® Diagonal Plow Assembly

***Installing plow onto mounting brackets***

1. Loosen four hex head cap screws and elastic lock nuts attaching blade (A, Figure 3) and frame (B) to adjustable brackets (C and D).
2. Remove quick-release pins (E) from adjustable brackets.
3. Insert pins on adjustable brackets through right and left side guide bushings (F).
4. Slide frame on adjustable brackets to center blade on belt. When centered, tighten screws and elastic lock nuts to secure blade in place. Make sure blade is resting on belt surface.
5. Install quick-release pins.

***Installing restraining cable***

**⚠ CAUTION**

**Restraining cable must be installed to prevent plow from being carried into pulley if mount brackets should fail. Failure to do so could severely damage plow, pulley and belt.**

1. Loop one end of hanger cable (A, Figure 4) through c-clamp hanger (B) and secure with cable clip (C).

**⚠ CAUTION**

**Do not install restraining cable on stringer that is between plow and tail pulley.**

2. Apply thread-locking compound to threads of square head set screw (D). Secure c-clamp hanger to same stringer on which mount bracket is installed or to another stringer that is between plow and head pulley. Tighten square head set screw.
3. Loop loose end of hanger cable through hole in frame and secure with cable clip. Leave no more than 2 in. (51 mm) of slack in cable.

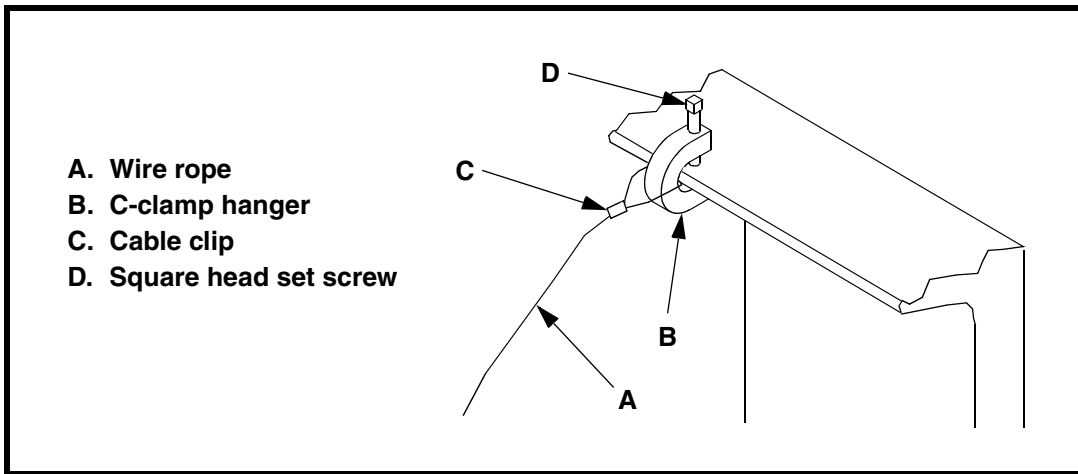

**Figure 4. Installing Restraining Cable**

# After Installing Plow

## IMPORTANT

Read entire section before beginning work.

1. Thoroughly wipe outside chute walls clean above Martin® Diagonal Plow on both sides of chute. Place Conveyor Products Warning Labels (P/N 23395) on chute walls visible to plow operator.

## WARNING

Failure to remove tools from installation area and conveyor belt before turning on energy source can cause serious injury to personnel and damage to belt.

2. Remove all tools and fire retardant cover from installation area and conveyor belt.

## DANGER

Do not touch or go near conveyor belt or conveyor accessories when conveyor belt is running. Body or clothing can get caught and pull body into conveyor belt, causing severe injury or death.

3. Turn on conveyor belt.

## WARNING

Before adjusting tail protection plow, turn off and lock out/tag out energy source to conveyor belt and conveyor accessories.

4. After one hour of operation, turn off and lock out/tag out energy source according to ANSI standards (see “References”).
5. Make sure all fasteners are tight. Tighten if necessary.
6. Inspect plow blade for wear. (A small amount of “break-in” wear may be found. This will stop once blade wears to conveyor belt contour.)
7. Make sure plow is pushing material off edge of belt efficiently, leaving minimal material on belt.
8. If wear, material buildup, or some other problem exists, see “Troubleshooting/Installation Checklist.”



## Weekly Maintenance

---

### NOTE

Maintenance inspection should be performed no less than weekly. Your application may require more frequent maintenance inspections.

### IMPORTANT

Read entire section before beginning work.

### ⚠ WARNING

Before servicing tail protection plow, turn off and lock out/tag out energy source to conveyor belt and conveyor accessories.



1. Turn off and lock out/tag out energy source according to ANSI standards (see “References”).
2. Make sure all fasteners are tight. Tighten if necessary.
3. Check blade for wear. If blade no longer contacts belt and adjustable brackets (C and D, Figure 3) are resting on guide bushings (F), do the following:
  - a. Remove hex head cap screws, flat washers, and elastic lock nuts attaching blade (A) and frame (B) to adjustable brackets.
  - b. Remove worn blade and install a new blade.
  - c. Install blade onto frame and adjustable brackets with hex head cap screws, elastic lock nuts, and flat washers but do not tighten.
  - d. Slide frame on adjustable brackets to center blade on belt. When centered, tighten screws and elastic lock nuts to secure blade in place. Make sure blade is resting on belt surface.
4. Check restraining cable for wear. Make sure c-clamp hanger is securely attached to stringer.
5. Remove equipment from service if there is any indication it is not functioning properly. Call Martin Engineering or representative for assistance. Do NOT return equipment to operation until the cause of the problem has been identified and corrected.
6. Wipe warning labels clean. If labels are not readable, contact Martin Engineering or a representative for replacements.



**⚠ WARNING**

Failure to remove tools from maintenance area and conveyor belt before turning on energy source can cause serious injury to personnel and damage to belt.

7. Remove all tools from maintenance area.

**⚠ DANGER**

Do not touch or go near conveyor belt or conveyor accessories when conveyor belt is running. Body or clothing can get caught and pull body into conveyor belt, causing severe injury or death.

8. Start conveyor belt.



# Troubleshooting/Installation Checklist

## *Troubleshooting*

If you are experiencing problems with tail pulley protection plow, see below:

Symptom	Corrective Action
Material buildup on blade.	Plow is not installed at 45° angle. Check angle and re-install if necessary.
Insufficient cleaning and carryback.	Check blade for excessive wear and replace if necessary.

## *Installation checklist*

If after taking corrective actions suggested under “Troubleshooting” you are still experiencing problems, check for the following:

Installation Checklist
- Martin® Diagonal Plow is installed where belt is taut or supported by idler(s).
- Plow is installed at 45° angle across belt.
- Blade is perpendicular to belt.
- Blade is centered on belt.

### NOTE

Conveyor equipment such as conveyor belt diagonal plows are subject to a wide variety of bulk materials characteristics and often have to perform under extreme operating or environmental conditions. It is not possible to predict all circumstances that may require troubleshooting. Contact Martin Engineering or a representative if you are experiencing problems other than those listed in the “Troubleshooting” chart above. Do not return the equipment to operation until the problem has been identified and corrected.

# Part Numbers

Figure 5 provides product names and corresponding part numbers for Martin® Diagonal Plows. Please reference part numbers when ordering parts.

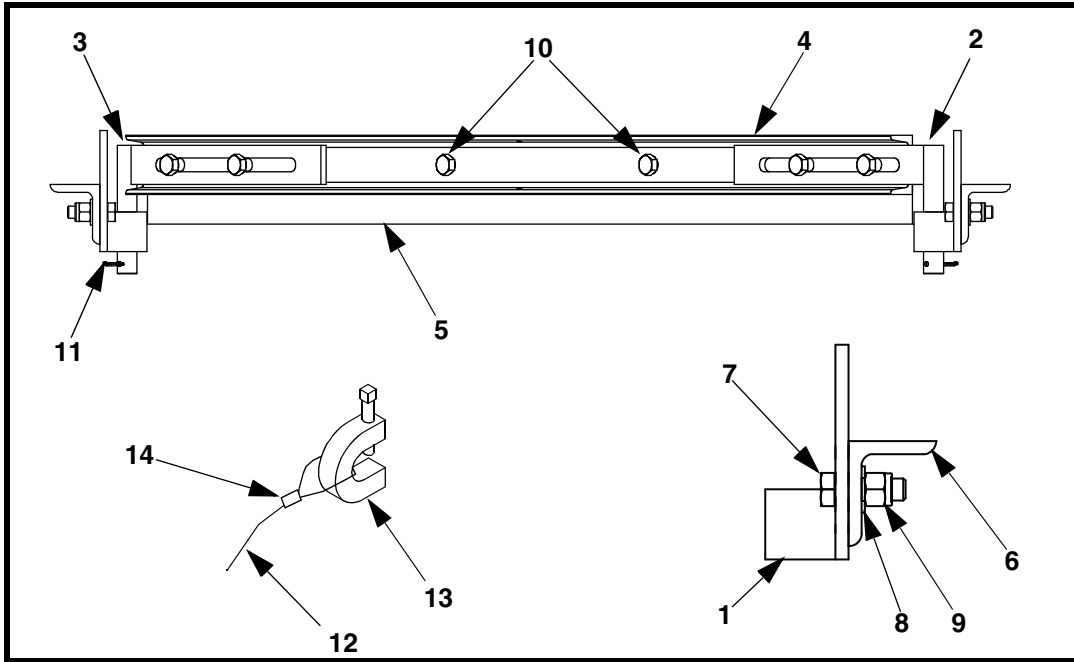

Item	Description	Part No.	Qty
1	Mount Bracket Weldment	37443	2
2	Adjustable End Weldment (Right)	37477-R	1
3	Adjustable End Weldment (Left)	37477-L	1
4	Frame Channel	Table II	1
5	Blade	Table III	1
6	Mount Bracket f/Reversing Wiper Plow	23446	2
7	Screw HHC 5/8 - 11NC x 2 SS	26288	4
8	Washer Flat 5/8 Narrow SS	17154	Table II
9	Nut Hex Elastic Lock 5/8 - 11NC SS	24242	Table II
10	Screw HHC 5/8 - 11NC x 2 - 3/4 SS	23361	Table II
11	Pin Quick-lock Release 1/4 x 1.00 ZP	23453	2
12	Wire Rope 1/8 SS	100107	Table II
13	C-clamp Hanger	23483	1
14	Cable Clip for J25 Diagonal Cable	23481	2
15	Label Martin Products	32238	1
Fig. 6	Label Conveyor Products Warning	23395	2
Fig. 7	Label Flying Objects Warning	38227	2
	Operator's Manual	M3239	1

**Figure 5. Martin® Diagonal Plow Assembly, P/N 22662-XXX\***

\*First XX indicates belt width in inches; third X indicates type of blade (R) rubber or (U) urethane (see Table III).

**Table II. Martin® Diagonal Plow Assembly Part Quantities**

<b>Belt Width in. (mm)</b>	<b>Quantity Items 8 &amp; 9</b>	<b>Length Item 12 ft. (mm)</b>	<b>Quantity Item 10</b>	<b>Part No. Item 4</b>
18 (400 - 500)	8	2.75 (838)	4	24114-18
24 (500 - 650)	9	3.00 (914)	5	24114-24
30 (650 - 800)	9	3.25 (991)	5	24114-30
36 (800 - 1000)	10	3.50 (1067)	6	24114-36
42 (1000 - 1200)	11	3.75 (1143)	7	24114-42
48 (1200 - 1400)	11	4.00 (1219)	7	24114-48
54 (1400 - 1600)	12	4.25 (1295)	8	24114-54
60 (1600 - 1800)	12	4.50 (1372)	8	24114-60
66 (1600 - 1800)	13	4.75 (1448)	9	24114-66
72 (1800 - 2000)	13	5.00 (1524)	9	24114-72
84 (2000 - 2200)	14	5.50 (1676)	10	24114-84
96 (2200 - 2400)	15	6.00 (1829)	11	24114-96
120 (2800 - 3000)	18	7.67 (2338)	14	24114-120

**Table III. Martin® Diagonal Plow Blade Part Numbers**

<b>Assembly Part Number</b>	<b>Rubber Blade Part Number</b>	<b>Urethane Blade Part Number</b>
22662-18X	24112-18	25403-18
22662-24X	24112-24	25403-24
22662-30X	24112-30	25403-30
22662-36X	24112-36	25403-36
22662-42X	24112-42	25403-42
22662-48X	24112-48	25403-48
22662-54X	24112-54	25403-54
22662-60X	24112-60	25403-60
22662-66X	24112-66	25403-66
22662-72X	24112-72	25403-72
22662-84X	24112-84	25403-84
22662-96X	24112-96	25403-96
22662-120X	24112-120	25403-120



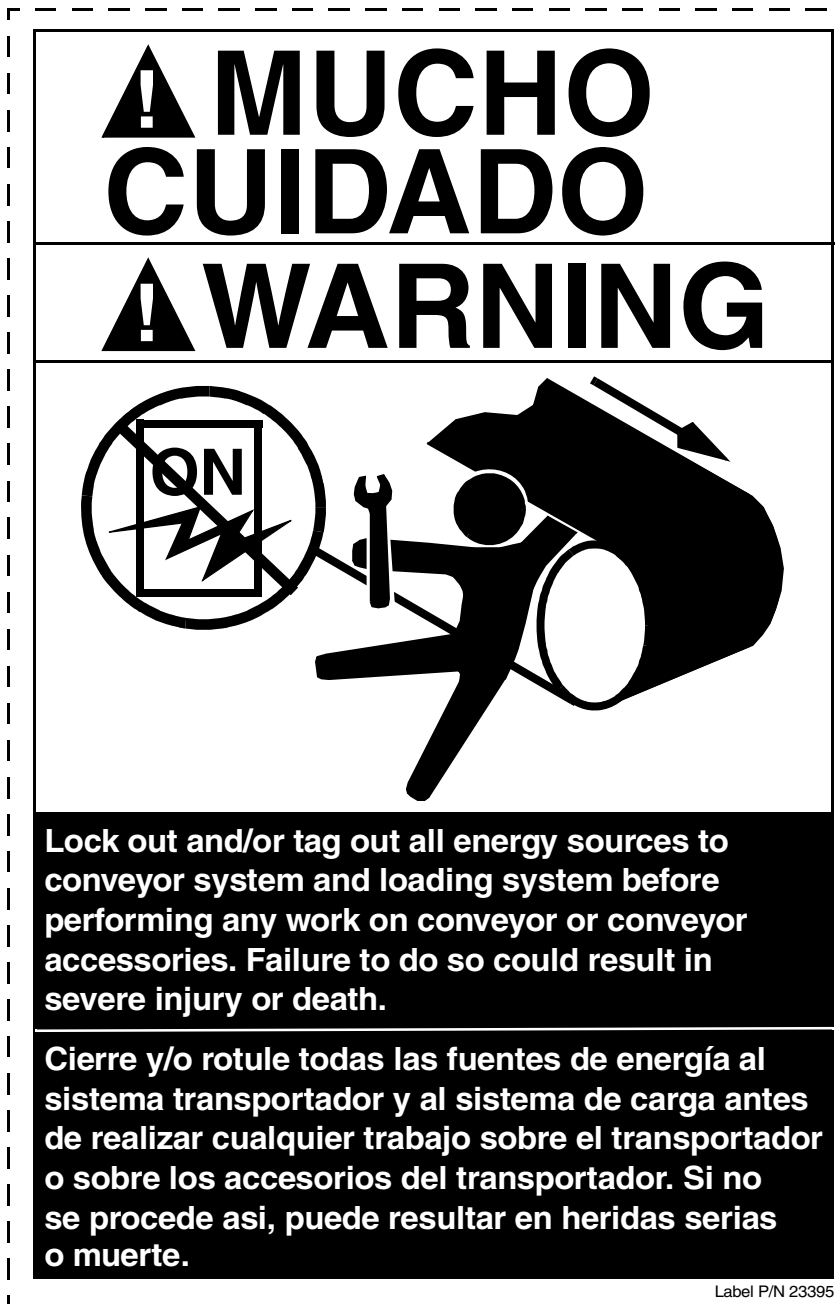

Figure 6. Conveyor Products Warning Label, P/N 23395



Figure 7. Flying Objects Warning Label, P/N 38227

*Any product, process, or technology described here may be the subject of intellectual property rights reserved by Martin Engineering Company. Trademarks or service marks designated with the ® symbol are registered with the U.S. Patent and Trademark Office and may be proprietary in one or more countries or regions. Other trademarks and service marks belonging to Martin Engineering Company in the United States and/or other countries or regions may be designated with the “TM” and “SM” symbols. Brands, trademarks, and names of other parties, who may or may not be affiliated with, connected to, or endorsed by Martin Engineering Company, are identified wherever possible. Additional information regarding Martin Engineering Company’s intellectual property can be obtained at [www.martin-eng.com/trademarks](http://www.martin-eng.com/trademarks).*

# Problem Solved™ GUARANTEED!

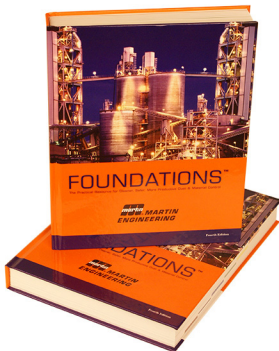

*For nearly 20 years, Martin Engineering's Foundations™ Books have taught industry personnel to operate and maintain clean and safe belt conveyors. The Foundations™ Book, fourth edition, focuses on improving belt conveyors by controlling fugitive material. "The Practical Resource for Total Dust and Material Control," is a 576-page hard cover volume that provides information of value to industries where the efficient handling of bulk materials is a key to productivity and profitability.*

*Expanding upon the book, our Foundations™ Training Program addresses the design and development of more productive belt conveyors, and is offered in three customizable seminars. Attendees gain a better understanding of conveyor safety and performance, helping to justify upgrade investments and increase profitability.*



**Martin Engineering Australia Pty Ltd.**  
20 Ern Harley Dr - Burleigh Heads, QLD, 4220 - Australia  
1300 627 364  
[www.martin-eng.com.au](http://www.martin-eng.com.au)

