

Martin® 2000 Pneumatic Piston Vibrator Series

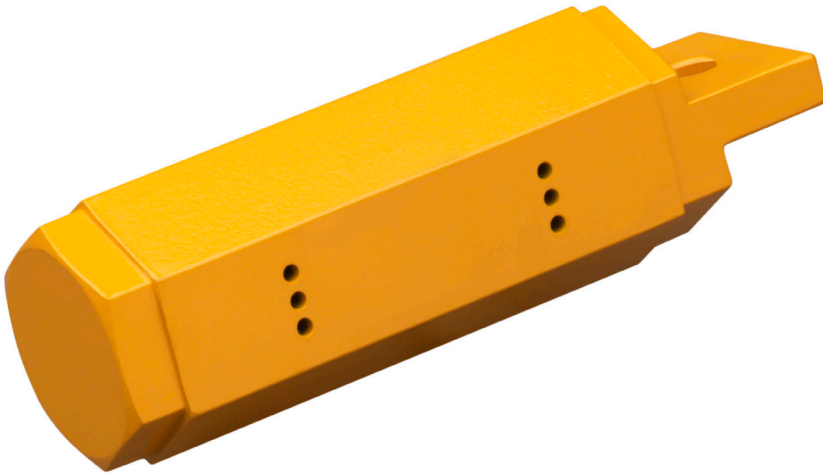

FEATURES

- Alloy steel bodies
- Hardened pistons
- Low air consumption
- Produces uniform directional force
- Optional
 - internal spring for positive starting
 - manifold/muffler for quiet operation
 - air cushioned non-impacting
 - universal mount
 - high-temperature up to 400°F

Specify Cougar for:

- Cost effective solutions
- Expert technical assistance
- Complete service and support

TECHNICAL DATA SHEET

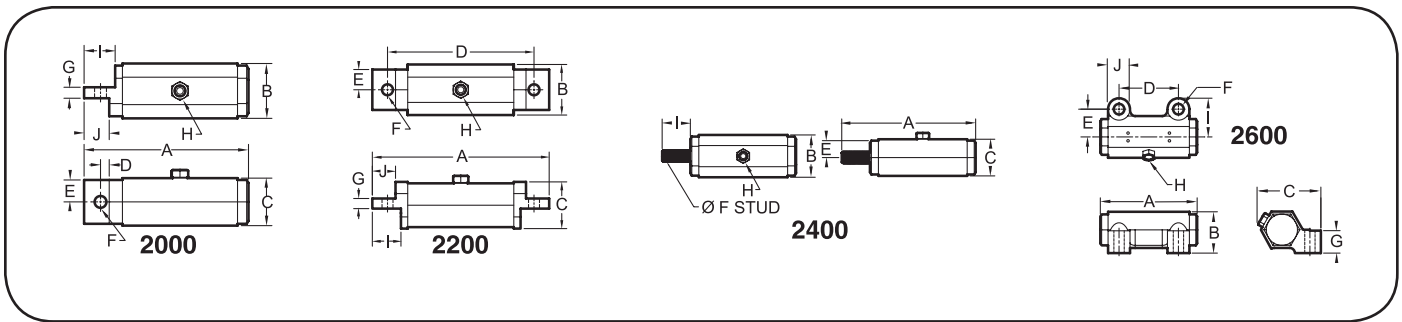

DIMENSIONS (inch)

Model	Piston Size In.	A	B	C	Bolt Pattern		Bolt Size	G	Port NPT	I	J	Weight lbs
					D	E						
2006/2006-AC	3/4	5.500	1.625	1.375	5/16	5/8	3/8	0.375	1/8	0.938	0.750	2.25
2008/2008-AC	1	5.625	1.875	1.625	5/16	3/4	3/8	0.375	1/8	1.063	0.875	3.25
2010/2010-AC	1 1/4	9.250	2.313	2.000	7/16	13/16	1/2	0.875	1/4	1.375	1.125	7.25
2012/2012-AC	1 1/2	9.313	2.875	2.500	1/2	1	5/8	0.875	1/4	1.438	1.125	11.50
2016/2016-AC	2	9.875	3.500	3.000	13/16	1 1/4	7/8	0.938	1/4	20.63	1.563	17.00
2206/2206-AC	3/4	6.313	1.625	1.375	5 7/16	5/8	3/8	0.375	1/8	0.938	0.750	2.25
2208/2208-AC	1	6.563	1.875	1.625	5 7/16	3/4	3/8	0.375	1/8	1.063	0.875	3.50
2210/2210-AC	1 1/4	10.500	2.313	2.000	9 1/8	13/16	1/2	0.875	1/4	1.375	1.125	7.50
2212/2212-AC	1 1/2	10.625	2.875	2.500	9 1/2	1	5/8	0.875	1/4	1.438	1.063	12.50
2216/2216-AC	2	11.813	3.500	3.000	10 1/4	1 1/4	7/8	0.938	1/4	2.063	1.563	19.25
2306/2306-AC	3/4	6.188	3.313	1.375	1 1/8	3/4	1/2	1.875	1/8	0.500	0.500	2.50
2408/2408-AC	1	6.000	1.875	1.625	—	3/4	1/2	—	1/8	1.250	—	3.50
2410/2410-AC	1 1/4	9.375	2.313	2.000	—	13/16	5/8	—	1/4	1.375	—	7.50
2412/2412-AC	1 1/2	9.375	2.875	2.500	—	1	5/8	—	1/4	1.375	—	12.50
2416/2416-AC	2	9.875	3.500	3.000	—	1 1/4	7/8	—	1/4	1.875	—	19.25
2608/2608-AC	1	4.750	2.000	1.750	2 7/8	1 3/8	1/2	1.125	3/8	1.875	1.063	4.50
2610/2610-AC	1 1/4	8.000	2.250	2.125	3 3/4	1 11/16	1/2	1.375	1/4	2.313	1.250	8.50
2612/2612-AC	1 1/2	8.000	2.750	2.375	4	1 15/16	5/8	1.500	1/4	2.563	1.250	10.50

PERFORMANCE DATA

Model	Piston Size In.	40 PSI		60 PSI		MAX 80 PSI	
		VPM	CFM	VPM	CFM	VPM	CFM
-06	3/4	13500	4.1	20000	6.4	22000	8.1
-08	1	9000	2.7	14000	4.0	16000	5.4
-10	1 1/4	4500	5.5	5800	8.0	6500	10.8
-12	1 1/2	4500	4.1	6000	7.2	6800	9.9
-16	2	4250	7.5	5600	12.7	6000	17.0

Model	Piston Size In.	40 PSI		60 PSI		MAX 80 PSI	
		VPM	CFM	VPM	CFM	VPM	CFM
-06-AC	3/4	4100	2.7	4600	4.0	5100	5.4
-08-AC	1	4100	3.8	4800	4.8	5500	6.3
-10-AC	1 1/4	2000	5.5	2500	8.0	2800	10.8
-12-AC	1 1/2	2000	4.8	2250	7.2	2600	9.0
-16-AC	2	1900	6.1	2400	10.4	2850	13.5

ACCESSORIES

Part Number	Description
39504	Control Line Kit
14824-PR	Ball Valve 1/2" NPT
14760-PR	Filter, Regulator, Lubricator Combination, 1/2" NPT
14766-PR	Air Motor Oil (qt)
38902-20	On/Off Cycle Timer 115/1/60
36343-NC	Solenoid Valve 115/1/60, 1/2" NPT



Martin Engineering Australia Pty Ltd.
 20 Ern Harley Dr - Burleigh Heads, QLD, 4220 - Australia
 1300 627 364
www.martin-eng.com.au



Problem Solved™ GUARANTEED!

Form No. L3846-11/19
 © Martin Engineering Company 2012, 2019