

martin®

Martin® Twist Tensioner



Operator's Manual M3837

Important

MARTIN ENGINEERING HEREBY DISCLAIMS ANY LIABILITY FOR: DAMAGE DUE TO CONTAMINATION OF THE MATERIAL; USER'S FAILURE TO INSPECT, MAINTAIN AND TAKE REASONABLE CARE OF THE EQUIPMENT; INJURIES OR DAMAGE RESULTING FROM USE OR APPLICATION OF THIS PRODUCT CONTRARY TO INSTRUCTIONS AND SPECIFICATIONS CONTAINED HEREIN. MARTIN ENGINEERING'S LIABILITY SHALL BE LIMITED TO REPAIR OR REPLACEMENT OF EQUIPMENT SHOWN TO BE DEFECTIVE.

Observe all safety rules given herein along with owner and Government standards and regulations. Know and understand lockout/tagout procedures as defined by American National Standards Institute (ANSI) z244.1-1982, *American National Standard for Personnel Protection - Lockout/Tagout of Energy Sources - Minimum Safety Requirements* and Occupational Safety and Health Administration (OSHA) Federal Register, Part IV, 29 CFR Part 1910, *Control of Hazardous Energy Source (Lockout/Tagout); Final Rule*.

The following symbols may be used in this manual:



Danger: Immediate hazards that will result in severe personal injury or death.



Warning: Hazards or unsafe practices that could result in personal injury.



Caution: Hazards or unsafe practices that could result in product or property damages.



Important: Instructions that must be followed to ensure proper installation/operation of equipment.



Note: General statements to assist the reader.

Table of Contents

Section	Page
List of Figures and Tables	ii
Introduction	1
General	1
Installations without chutework	1
Belt cleaner inspection access	1
References	1
Materials required	1
Safety	2
Before Installing Tensioner	3
Installing Tensioner and Belt Cleaner	4
Installing mounting plates	4
Cutting belt cleaner mainframe	6
Installing tensioner and belt cleaner	7
After Installing Tensioner and Belt Cleaner	9
Maintenance	10
Installing new tensioner sleeve	10
Troubleshooting	12
Part Numbers	13

List of Figures

Figure	Title	Page
1	Locating Mounting Plates	4
2	Martin® Twist Tensioner Assembly	5
3	Cutting Belt Cleaner Mainframe	6
4	Installing Martin® Twist Tensioner	7
5	Maintaining Martin® Twist Tensioner	10
6	Martin® Twist Tensioner Assembly, P/N 38850-X	14
7	Martin® Twist Tensioner Assembly, P/N 38850-2X	16
8	Martin® “L” Bracket Tensioner Mounting Kit, P/N 38844	18
9	Martin® Twist Tensioner Dimensions	19
10	Martin® “L” Bracket Dimensions	20
11	Conveyor Products Warning Label, P/N 23395	21
12	Pinch Point Warning Label, P/N 30528	21
13	Martin® Twist Tensioner Label, P/N 33383	21

List of Tables

Table	Title	Page
I	Martin® Twist Tensioner Recommended Tension	8
II	Martin® Twist Tensioner Assembly Part Numbers and Quantities	15
III	Martin® Twist Tensioner Assembly Part Numbers and Quantities	17

Introduction

General

The Martin® Twist Tensioner uses a rugged rubber tensioning element to supply consistent pressure against the conveyor belt regardless of blade wear. Once the tensioner has been rotated into position, it maintains effective cleaning with minimal adjustment. The Martin® Twist Tensioner is “self-relieving” because if blades are pulled through by splices, imperfections in the belt, or blades worn past their design limits, the tensioner’s internal hub rolls over while the outside hub remains stationary. This design allows releasing tension on the rubber tensioning element without exposing personnel to possible injury from a rotating external hub.

Installations without chutework

These procedures were written for equipment that is being installed on enclosed pulley chutework. If the pulley is not enclosed, the equipment should be installed using the best available field resources and methods to ensure that the critical dimensions are followed for proper installation.

The Martin® Hanger Mount, P/N 27382, can be used for installations without chutework.

Belt cleaner inspection access

If the belt cleaner is installed on enclosed pulley chutework, a Martin® Inspection Door should be installed. Martin® Inspection Doors are available from Martin Engineering or your representative.

References

The following documents are referenced in this manual:

- American National Standards Institute (ANSI) z244.1-1982, *American National Standard for Personnel Protection - Lockout/Tagout of Energy Sources - Minimum Safety Requirements*, American National Standards Institute, Inc., 1430 Broadway, New York, NY 10018.
- Federal Register, Volume 54, Number 169, Part IV, 29 CFR Part 1910, *Control of Hazardous Energy Source (Lockout/Tagout); Final Rule*, Department of Labor, Occupational Safety and Health Administration (OSHA), 32nd Floor, Room 3244, 230 South Dearborn Street, Chicago, IL 60604.
- *Martin® Inspection Door Operator’s Manual*, P/N M3891.
- *Martin® QCI™ Cleaner HD Operator’s Manual*, P/N M3618.
- *Martin® QCI™ Pre-Cleaner with Metal Tipped Blade Operator’s Manual*, P/N M3814.
- *Durt Hawg® DH2 Cleaner Operator’s Manual*, P/N M3619.
- *Martin® PV Cleaner Operator’s Manual*, P/N M3735.

Materials required

Installation of this equipment requires the use of standard hand tools, grinder, welder, and cutting torch.

Safety

All safety rules defined in the above documents and all owner/employer safety rules must be strictly followed when working on the belt cleaner.



⚠ DANGER

Do not touch or go near the conveyor belt or conveyor accessories when the belt is running. Your body or clothing can get caught and you can be pulled into the conveyor, resulting in severe injury or death.



⚠ DANGER

Before installing, servicing, or adjusting conveyor equipment, turn off and lockout / tagout / blockout / testout all energy sources to the conveyor and conveyor accessories according to ANSI standards. Failure to do so could result in serious injury or death.

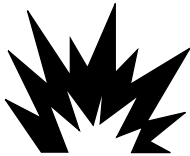

⚠ DANGER

If this equipment will be installed in an enclosed area, test the gas level or dust content before using a cutting torch or welding. Using a torch or welding in an area with gas or dust may cause an explosion resulting in serious injury or death. Follow local confined space procedures.



⚠ WARNING

Before using a cutting torch or welding the chute wall, cover the conveyor belt with a fire retardant cover. Failure to do so can allow the belt to catch fire. Follow local fire watch procedures.

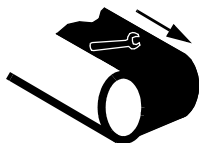

⚠ WARNING

Remove all tools from the installation area and conveyor belt before turning on the conveyor. Failure to do so can cause serious injury to personnel or damage to the belt and conveyor.

Before Installing Tensioner

IMPORTANT

The delivery service is responsible for damage occurring in transit. Martin Engineering CANNOT enter claims for damages. Contact your transportation agent for more information.

1. Inspect shipping container for damage. Report damage to delivery service immediately and fill out delivery service's claim form. Keep any damaged goods subject to examination.
2. Remove tensioner assembly from shipping container.
3. If anything is missing contact Martin Engineering or a representative.



⚠ DANGER

Before installing, servicing, or adjusting conveyor equipment, turn off and lockout / tagout / blockout / testout all energy sources to the conveyor and conveyor accessories according to ANSI standards. Failure to do so could result in serious injury or death.

4. Turn off and lockout / tagout / blockout / testout energy source according to ANSI standards (see "References").

⚠ DANGER

If this equipment will be installed in an enclosed area, test the gas level or dust content before using a cutting torch or welding. Using a torch or welding in an area with gas or dust may cause an explosion resulting in serious injury or death.

5. If using a cutting torch or welding, test atmosphere for gas level or dust content. Cover conveyor belt with fire retardant cover.

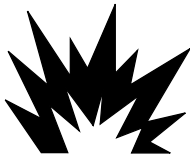

NOTE

The chute wall that the tensioner will be located on is referred to as the "operator side." The other side of the chute is referred to as the "far side." (If installing dual tensioners, side that is most accessible is "operator side.")

6. Determine which side of chute is easiest to access. Locate the tensioner on the most accessible chute wall.

Installing Tensioner and Belt Cleaner

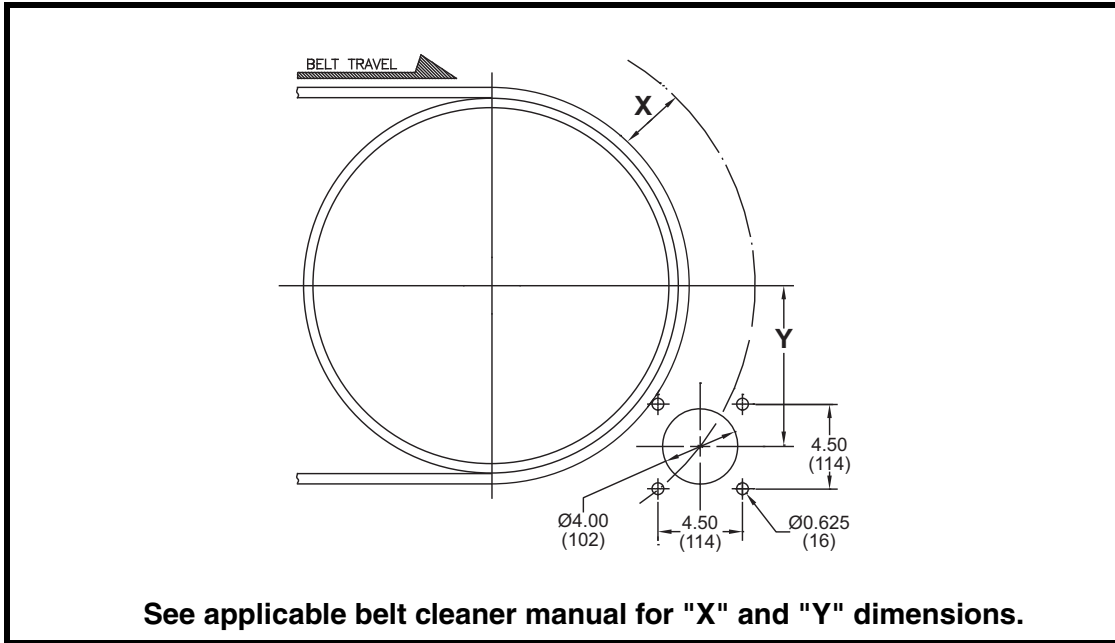

Figure 1. Locating Mounting Plates

Installing mounting plates

1. Mark location of holes for belt cleaner mounting plates on chute walls according to Figure 1. Use flange plate weldment (H, Figure 2) as template.
2. Position mounting plates parallel to pulley's horizontal center line.

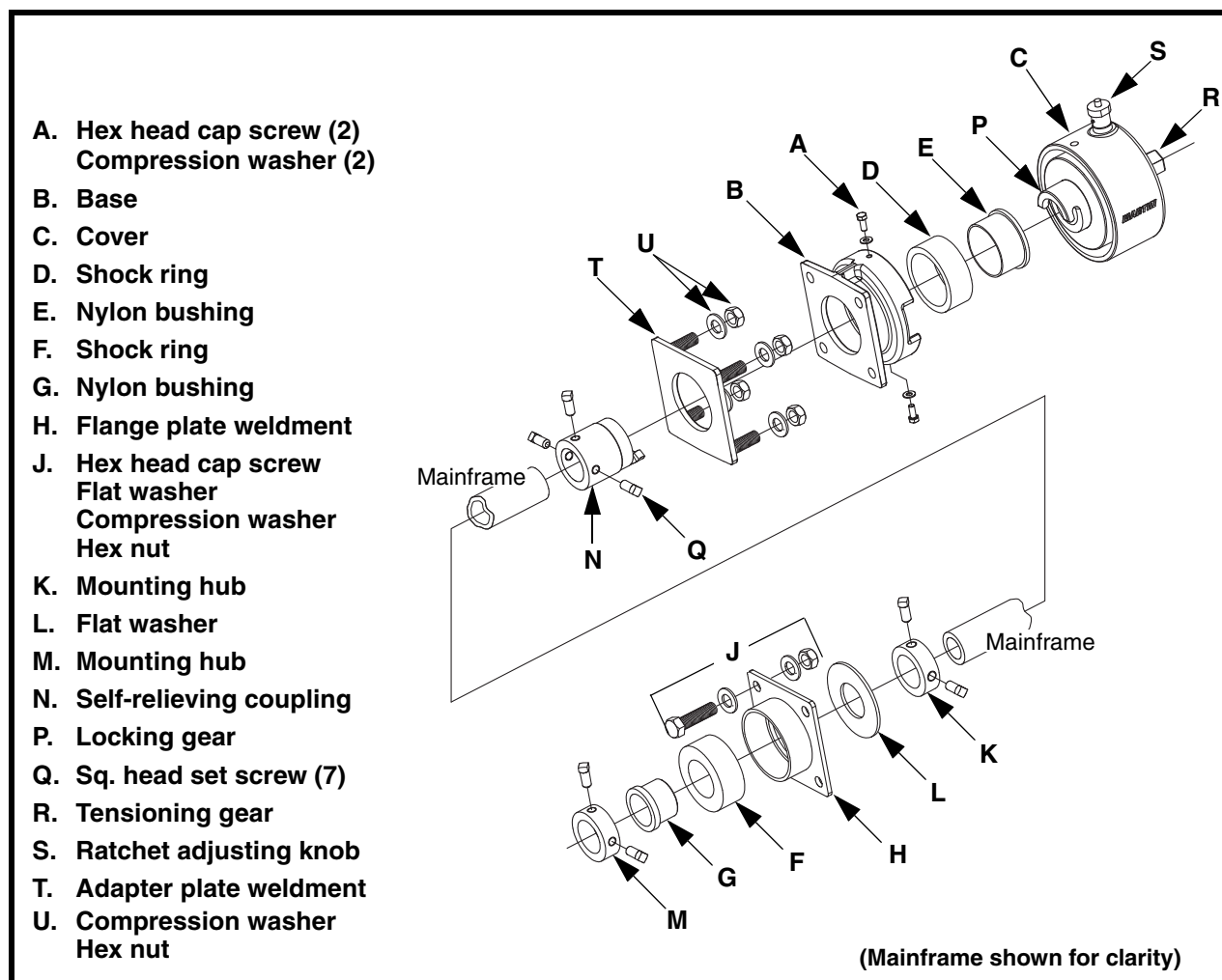

Figure 2. Martin® Twist Tensioner Assembly

3. Bolt or weld mounting plates to chute walls as follows:
 - a. If bolting mounting plates to chute walls, do the following:
 - (1) Drill or cut one 4-in. hole for mainframe and four 5/8-in. holes for screws in both operator side and far side chute walls. Remove burrs and sharp edges.
 - (2) Install tensioner assembly and mounting plate onto wall with cap screws, flat washers, compression washers, and nuts (J, Figure 2).
 - b. If welding mounting plates to chute walls, do the following:
 - (1) Drill or cut one 4-in. hole for mainframe in both operator side and far side chute walls. Remove burrs and sharp edges.
 - (2) Position adapter plate weldment (T) over hole on operator side and weld onto chute wall.
 - (3) Position mounting flange (H) over hole on far side and weld onto chute wall.
 - (4) Install tensioner assembly on adapter plate weldment (T) and fasten with compression washers and nuts (U).

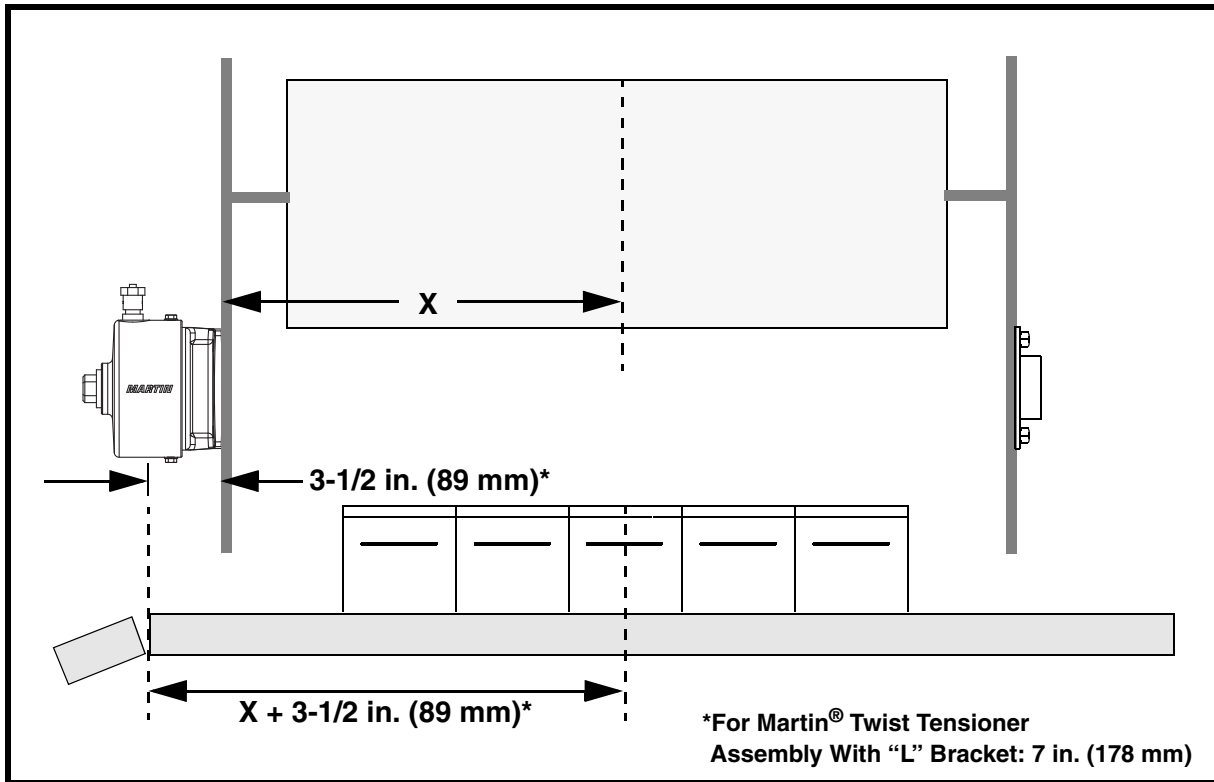

Figure 3. Cutting Belt Cleaner Mainframe

Cutting belt cleaner mainframe

IMPORTANT

The procedure in this section is only for belt cleaners with one-piece mainframes. Do not cut three-piece telescoping mainframes.

1. See Figure 3. Measure from center of conveyor belt to outside of operator side chute wall (X).
2. Add 3-1/2 in. (89 mm) to the measurement in step 1. (If installing Martin® Twist Tensioner Assembly With “L” Bracket, add 7 in. [178 mm] to the measurement in step 1.)
3. Starting from center of belt cleaner mainframe, measure toward operator end of the mainframe the distance found in step 2: X + 3-1/2 in. (89 mm). (If installing Martin® Twist Tensioner Assembly With “L” Bracket: X + 7 in. [178 mm].)

▲ WARNING

Before cutting mainframe with torch, remove plastic plugs from ends of mainframe. Cutting mainframe with plugs intact can cause paint fumes inside mainframe to ignite.

4. Cut belt cleaner mainframe. Remove burrs and sharp edges.

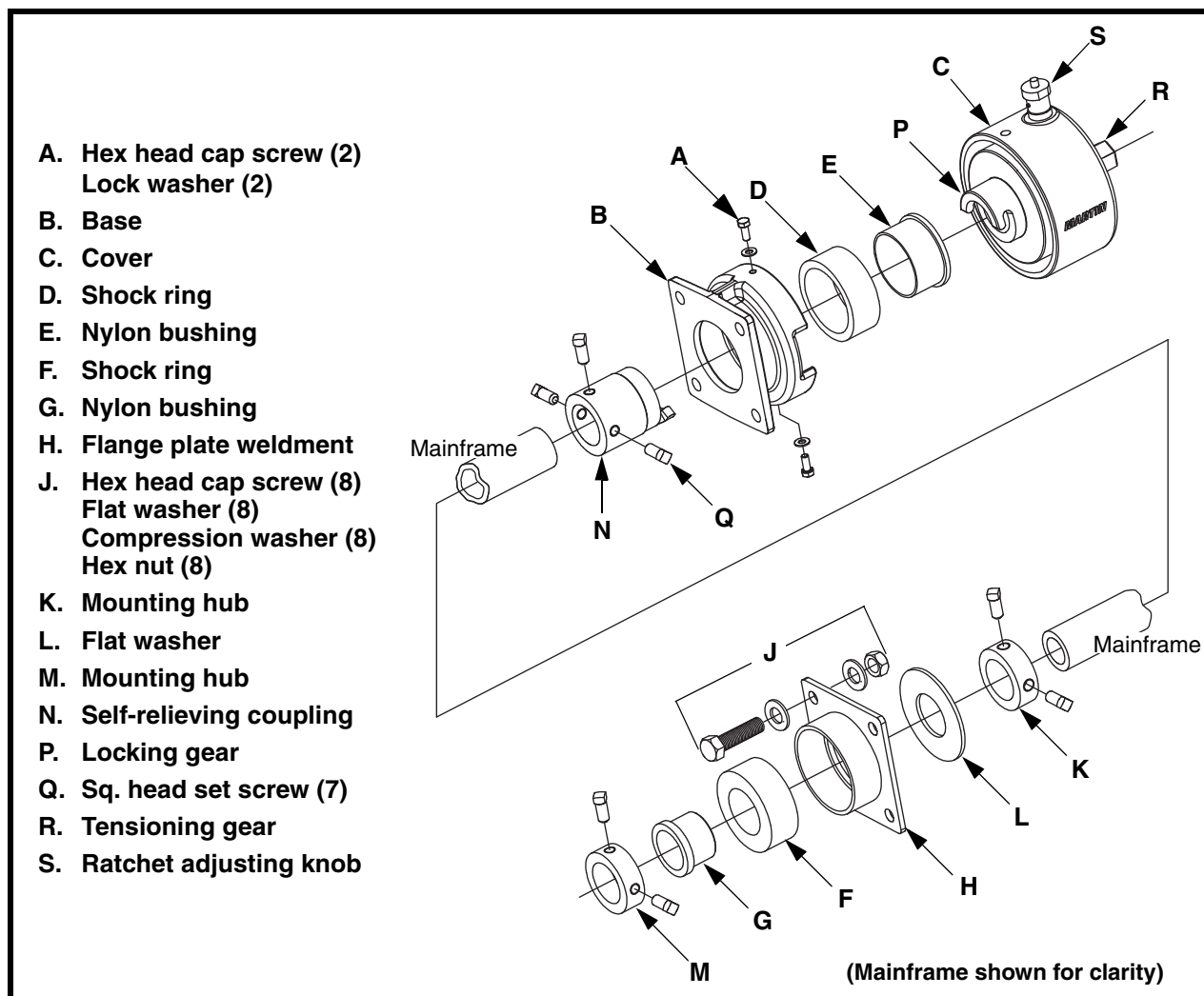

Figure 4. Installing Martin® Twist Tensioner

Installing tensioner and belt cleaner

1. Slide mounting hub (K) and flat washer (L) onto far side end of belt cleaner mainframe. Insert far side end of mainframe through nylon bushing (G) in flange plate weldment (H). Slide mounting hub (M) onto far side end of mainframe.
2. Slide self-relieving coupling (N) onto operator side end of mainframe.
3. Insert operator side end of mainframe into nylon bushing (E) in base (B).
4. Slide self-relieving coupling against locking gear (P) and twist until the two coupling halves engage. Adjust mainframe to center blades on belt.
5. Bolt or weld self-relieving coupling to mainframe as follows:
 - a. If bolting, tighten three square head set screws (Q) on self-relieving coupling.
 - b. If welding, do the following:
 - (1) Mark location of self-relieving coupling on mainframe.
 - (2) Remove operator side end of mainframe from base.

- (3) Weld self-relieving coupling to mainframe with three 1-in. (25-mm) fillet welds evenly spaced around end of self-relieving coupling.
- (4) Repeat steps 3 and 4.
6. Make sure blades are centered on belt and mainframe is parallel to belt.
7. Slide mounting hub (K) against flat washer (L) and mounting hub (M) against nylon bushing (G). Tighten two square head set screws (Q) on each locking collar.



Ensure that ratchet adjusting knob (S) is engaged allowing cleaner to rotate into head pulley only. If ratchet adjusting knob is not engaged, mainframe will rotate freely. Unsafe practices while ratchet adjusting knob is not engaged could result in personal injury or death.

8. Engage ratchet adjusting knob (S) down so cleaner will rotate into head pulley only.
9. Turn tensioning gear (R) toward head pulley until you feel resistance of blades against belt. The ratchet mechanism will allow mainframe to rotate one direction only. If tensioning gear will not turn, pull out ratchet adjusting knob (S), turn it 180°, and release.
10. Turn tensioning gear further according to Table I.

Table I. Martin® Twist Tensioner Recommended Tension

Belt Width in. (mm)	Number of Notches			
	Martin® QC1™ Cleaner HD	Durt Hawg® DH2 Cleaner	Martin® PV Cleaner	Martin® QC1™ Cleaner Metal Tipped
18 (400-500)	2	2	3	1
24 (500-650)	3	3	4	1
30 (650-800)	3	3	4	1
36 (800-1000)	4	4	4	1
42 (1000-1200)	5	5	5	1
48 (1200-1400)	6	6	5	1
54 (1400-1600)	3*	3*	4*	1*
60 (1600-1800)	4*	4*	4*	1*
72 (1800-2000)	5*	5*	5*	1*
84 (2000-2200)	5*	5*	5*	1*
96 (2200-2400)	6*	6*	6*	1*

*Per tensioner; dual tensioners required.

After Installing Tensioner and Belt Cleaner



1. Thoroughly wipe chute wall clean above tensioner.
2. Place Conveyor Products Warning Label (P/N 23395) on outside chute wall visible to belt cleaner operator.
3. Additional safety labels are available from CEMA. For more information regarding CEMA safety labels visit www.cemanet.org.

⚠ WARNING

Failure to remove tools from installation area and conveyor belt before turning on energy source can cause serious injury to personnel and damage to belt.

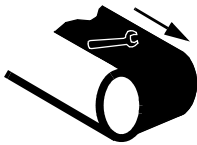

⚠ DANGER

Do not touch or go near conveyor belt or conveyor accessories when conveyor belt is running. Body or clothing can get caught and pull body into conveyor belt, causing severe injury or death.



4. Turn on conveyor belt for 1 hour, then turn off.

⚠ DANGER

Before installing, servicing, or adjusting conveyor equipment, turn off and lockout / tagout / blockout / testout all energy sources to the conveyor and conveyor accessories according to ANSI standards. Failure to do so could result in serious injury or death.



- a. Make sure all fasteners are tight. Tighten if necessary.
- b. Inspect belt cleaner for the following:
 - (1) Wear. (A small amount of “break-in” wear may be found. This will stop once blades wear to conveyor belt contour.)
 - (2) Material buildup. (No material between blades and return side of conveyor belt should be found.)
- c. If wear, material buildup, or some other problem exists, see “Troubleshooting.”

Maintenance

NOTE

Maintenance inspection should be performed no less than weekly. Some applications may require more frequent maintenance inspections.



⚠ DANGER

Before installing, servicing, or adjusting conveyor equipment, turn off and lockout / tagout / blockout / testout all energy sources to the conveyor and conveyor accessories according to ANSI standards. Failure to do so could result in serious injury or death.

1. Inspect Martin® Twist Tensioner sleeve for tears, cracks, or wear. If sleeve is worn or damaged, replace. (See “Installing new tensioner sleeve.”)
2. Lubricate ratchet adjusting mechanism.

Installing new tensioner sleeve

1. Relieve tension on belt cleaner as follows:
 - a. With wrench, turn tensioning gear (A, Figure 5) to slightly tension and release tensioner plunger (B) from teeth. Then, while holding wrench tightly, pull out ratchet adjusting knob (C), turn it 180°, and release.
 - b. Turn tensioning gear in the *opposite* direction so that blades are not tensioned against belt.
2. Remove old Martin® Twist Tensioner sleeve (D) as follows:
 - a. Remove two cap screws and washers (E) from cover (F).
 - b. Remove cover (F), nylon bushing (G), tensioning gear (A), and Martin® Twist Tensioner sleeve (D).

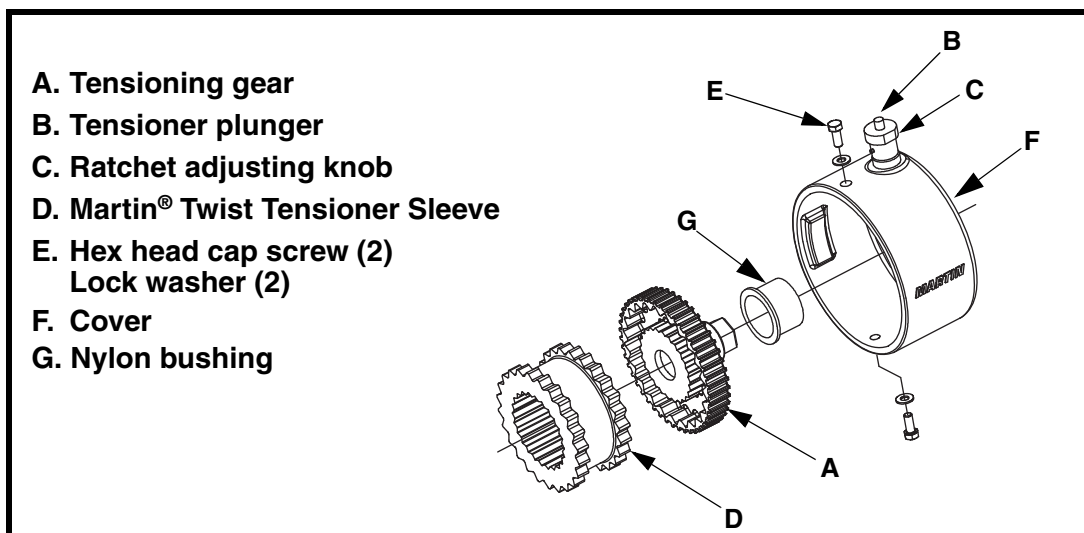

Figure 5. Maintaining Martin® Twist Tensioner

3. Discard old Martin® Twist Tensioner sleeve.
4. Inspect nylon bushing (G) and replace if necessary.

5. Install new Martin® Twist Tensioner sleeve (D), and reinstall tensioning gear (A), nylon bushing (G), and cover (F).
6. Install two cap screws and washers (E).

⚠ DANGER

Ensure that ratchet adjusting knob (C) is engaged. If ratchet adjusting knob is not engaged, mainframe will rotate freely. Unsafe practices while ratchet adjusting knob is not engaged could result in personal injury or death.

7. Turn tensioning gear (A) toward the head pulley until you feel resistance of blades against belt. The ratchet mechanism will allow mainframe to rotate one direction only. If tensioning gear will not turn, pull out ratchet adjusting knob (C), turn it 180°, and release.
8. Remove equipment from service if there is any indication it is not functioning properly. Call Martin Engineering or representative for assistance. Do NOT return equipment to operation until the cause of the problem has been identified and corrected.
9. Wipe all labels clean. If labels are not readable, contact Martin Engineering or representative for replacements.
10. Re-tension belt cleaner.

⚠ WARNING

Failure to remove tools from maintenance area and conveyor belt before turning on energy source can cause serious injury to personnel and damage to belt.

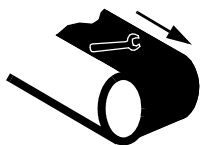

11. Remove all tools from maintenance area.

⚠ DANGER

Do not touch or go near conveyor belt or conveyor accessories when conveyor belt is running. Body or clothing can get caught and pull body into conveyor belt, causing severe injury or death.



12. Start conveyor belt. Observe belt cleaner operation for several revolutions of the belt. Service or adjust belt cleaner and tensioner as necessary to ensure proper belt cleaner operation.

Troubleshooting

Symptom	Corrective Action
Insufficient cleaning and carryback.	<ul style="list-style-type: none"> • Tension of cleaner on belt is set too low or too high. Increase or decrease tensioner setting. • Blades are worn. Check blades and replace if necessary.
Blade wears only in the center.	<ul style="list-style-type: none"> • Use a segmented style blade for crown pulleys. • Consider narrowing the blade width to clean the middle of the belt.
Noise or vibration.	Tension is not sufficient or is set too high. Correct tension as necessary. If this does not correct problem, blade urethane may not match application. Contact Martin Engineering or representative.
High blade wear rate.	Tension of cleaner on belt is set too high. Reduce tensioner setting.
Unusual wear or damage to blades.	Check belt splice(s) and repair as necessary.
Bent or broken mainframe or support frame due to blade slipping through.	If blades are worn to or past the wear line, replace blades. If blades are not worn, check mainframe location.
Corrosion or chemical degradation.	Blade urethane may not match application. Contact Martin Engineering or a representative.

NOTE

Conveyor equipment such as conveyor belt cleaners are subject to a wide variety of bulk materials characteristics and often have to perform under extreme operating or environmental conditions. It is not possible to predict all circumstances that may require troubleshooting. Contact Martin Engineering or a representative if you are experiencing problems other than those listed in the “Troubleshooting” chart above. Do not return the equipment to operation until the problem has been identified and corrected.

Installation checklist

If after taking the corrective actions suggested under “Troubleshooting” you are still experiencing problems, check for the following:

Installation Checklist
✓ Pre-Cleaner mainframe is proper distance from belt surface on both ends of mainframe and parallel to the pulley shaft.
✓ Pre-Cleaner blade tip does not lie in path of material flow.
✓ Blades are centered on belt.

Part Numbers

This section provides product names and corresponding part numbers for the Martin® Twist Tensioner and related equipment. Please reference part numbers when ordering parts.

Martin® Twist Tensioner Assemblies

Martin® Twist Tensioner Assembly: P/N 38850-X.

Dual Martin® Twist Tensioner Assemblies: P/N 38850-2X.

Optional equipment

"L" Bracket Mounting Kit: P/N 38844. Use to mount Martin® Twist Tensioner on chute wall with Martin® Inspection Door.

Flange Mount Bracket: P/N 30537. Use to mount Martin® Twist Tensioner on chute wall with Martin® Inspection Door.

Mandrel Belt Cleaner Mount: P/N 34280-30 or 34280-48. Replaces far side belt cleaner mount and allows you to service belt cleaner without reaching into chute.

Hanger Mount Assembly: P/N 27382. Use to mount Martin® Twist Tensioner on stringer instead of on chute wall.

Operator's manuals

Martin® Inspection Door Operator's Manual: P/N M3891.

Martin® QCI™ Cleaner HD Operator's Manual: P/N M3618.

Martin® QCI™ Pre-Cleaner with Metal Tipped Blade Operator's Manual: P/N M3814.

Durt Hawg® DH2 Cleaner Operator's Manual: P/N M3619.

Martin® PV Cleaner Operator's Manual: P/N M3735.

Other Martin Engineering belt cleaner operator's manuals as applicable.

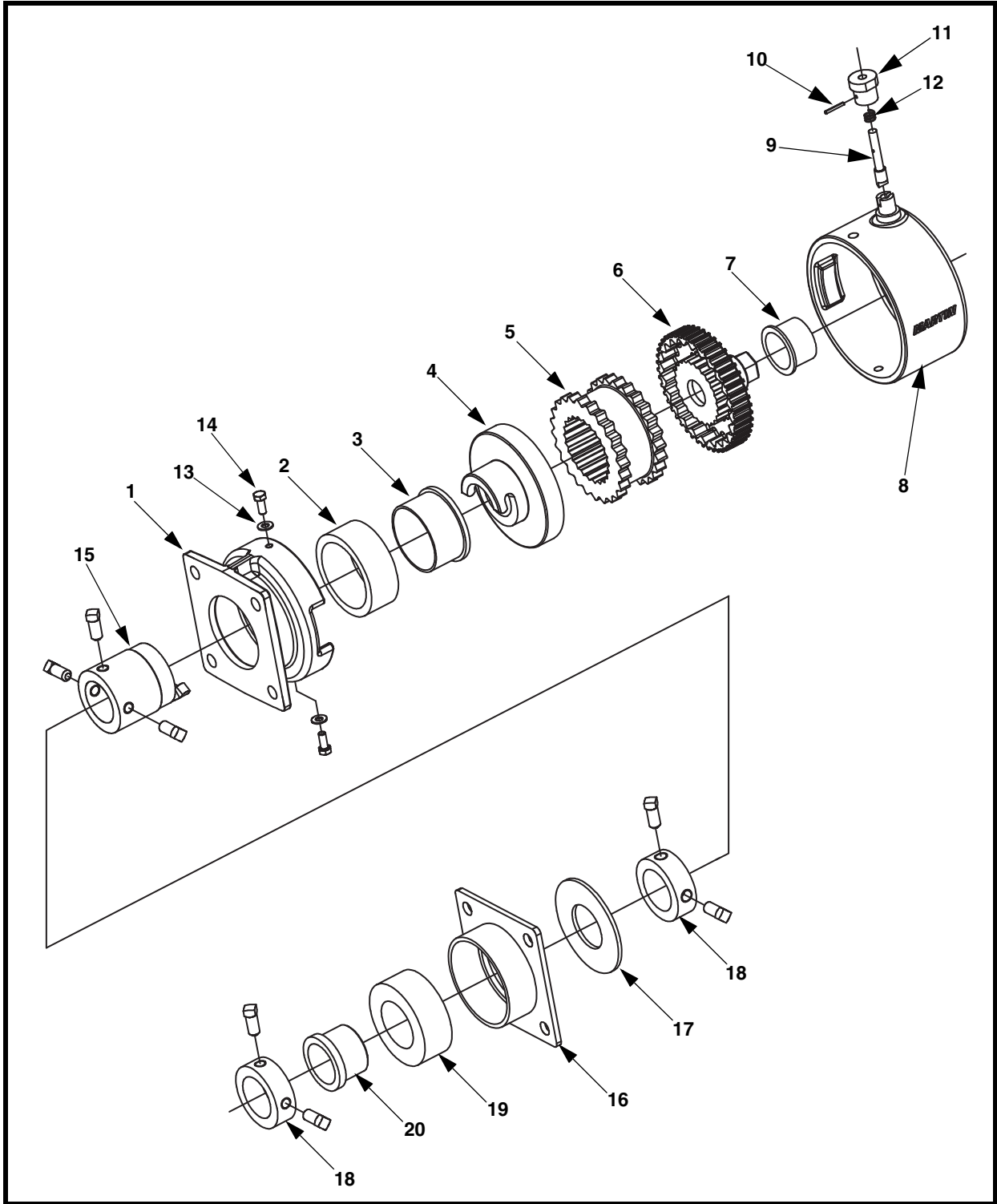

Figure 6. Martin® Twist Tensioner Assembly, P/N 38850-X* (Sheet 1 of 2)

*X indicates with weldable adapter plate kit (A), with "L" bracket mounting kit (L), or with metric mounting hardware (M).

Item	Description	Part No.	Qty
1	Machined Base	38711	1
2	Shock Ring	33681	1
3	Nylon Bushing 3.50 O.D.	33675	1
4	Locking Gear	33673	1
5	Sleeve	31398	1
6	Tensioning Gear Aluminum	33672	1
7	Nylon Bushing with Taper	33674	1
8	Machined Cover	38712	1
9	Plunger	33572	1
10	Pin Spring 1/8 x 1 ZP	33574	1
11	Ratchet Adjusting Knob	33570-TT	1
12	Spring Compression 1.00	33573	1
13	Washer Lock Helical Spring 5/16	M209	2
14	Screw HHC 5/16-18NC x 3/4 ZP	12250	2
15	Coupling Self-Relieving	Table II	1
16	Flange Plate Weldment	32496	1
17	Washer Flat 2.00 Plain	34802	1
18	Mounting Hub	16845	2
19	Shock Ring	32501	1
20	Nylon Bushing	33335	1
21 (NS)	Mounting Hardware Kit	Table II	1
Fig. 10	Label Pinch Point Warning	30528	1
Fig. 11	Label Tension	33383	1
Fig. 9	Label Conveyor Products Warning	23395	2
25 (NS)	Operator's Manual	M3837	1
26 (NS)	Adapter Plate Kit	38843-A	Tbl II
27 (NS)	"L" Bracket Kit	38844	Tbl II

Figure 6. Martin® Twist Tensioner Assembly, P/N 38850-X (Sheet 2 of 2)

NS = Not Shown

Table II. Martin® Twist Tensioner Assembly Part Numbers and Quantities

Assembly P/N	Item 15 P/N	Item 21 P/N	Item 26 Qty	Item 27 Qty
38850	33671	35284	—	—
38850-A	33671	35284	1	—
38850-L	33671-01	35284-01	—	1
38850-M	33671	35284-M	—	—

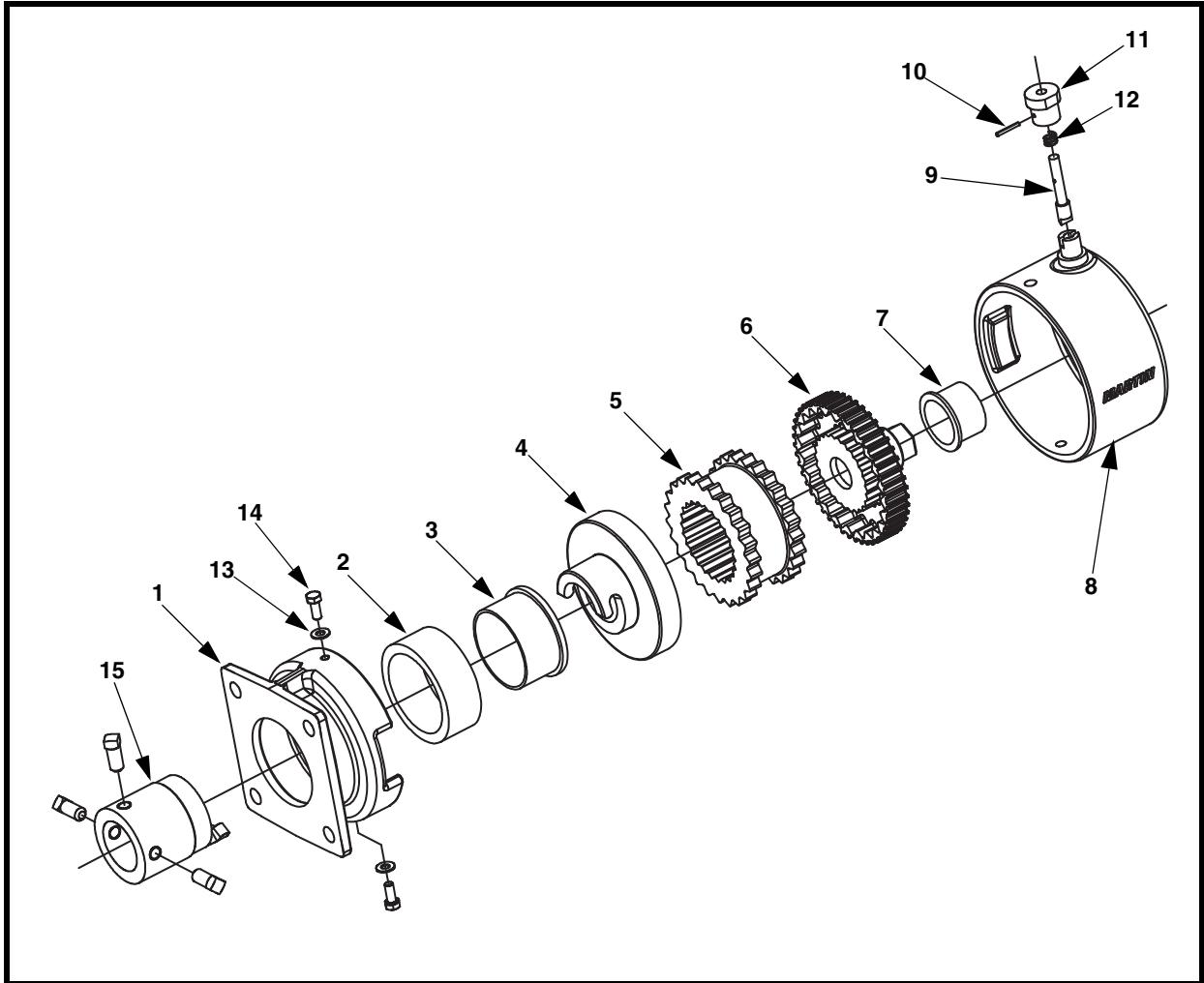

Figure 7. Martin® Twist Tensioner Assembly, P/N 38850-2X* (Sheet 1 of 2)

*X indicates with weldable adapter plate kit (A), with "L" bracket mounting kit (L), or with metric mounting hardware (M).

Item	Description	Part No.	Qty
1	Machined Base	38711	2
2	Shock Ring	33681	2
3	Nylon Bushing 3.50 O.D.	33675	2
4	Locking Gear	33673	2
5	Sleeve	31398	2
6	Tensioning Gear Aluminum	33672	2
7	Nylon Bushing with Taper	33674	2
8	Machined Cover	38712	2
9	Plunger	33572	2
10	Pin Spring 1/8 x 1 ZP	33574	2
11	Ratchet Adjusting Knob	33570-TT	2
12	Spring Compression 1.00	33573	2
13	Washer Lock Helical Spring 5/16	M209	4
14	Screw HHC 5/16-18NC x 3/4 ZP	12250	4
15	Coupling Self-Relieving	Table III	2
16 (NS)	Mounting Hardware Kit	Table III	1
Fig. 10	Label Pinch Point Warning	30528	2
Fig. 11	Label Tension	33383	2
Fig. 9	Label Conveyor Products Warning	23395	2
20 (NS)	Operator's Manual	M3837	1
21 (NS)	Adapter Plate Kit	38843-A	Tbl III
22 (NS)	"L" Bracket Kit	38844	Tbl III

Figure 7. Martin® Twist Tensioner Assembly, P/N 38850-2X (Sheet 2 of 2)

NS = Not Shown

Table III. Martin® Twist Tensioner Assembly Part Numbers and Quantities

Assembly P/N	Item 15 P/N	Item 16 P/N	Item 21 Qty	Item 22 Qty
38850-2	33671	35284	—	—
38850-2A	33671	35284	2	—
38850-2L	33671-01	35284-02	—	2
38850-2M	33671	35284-M	—	—

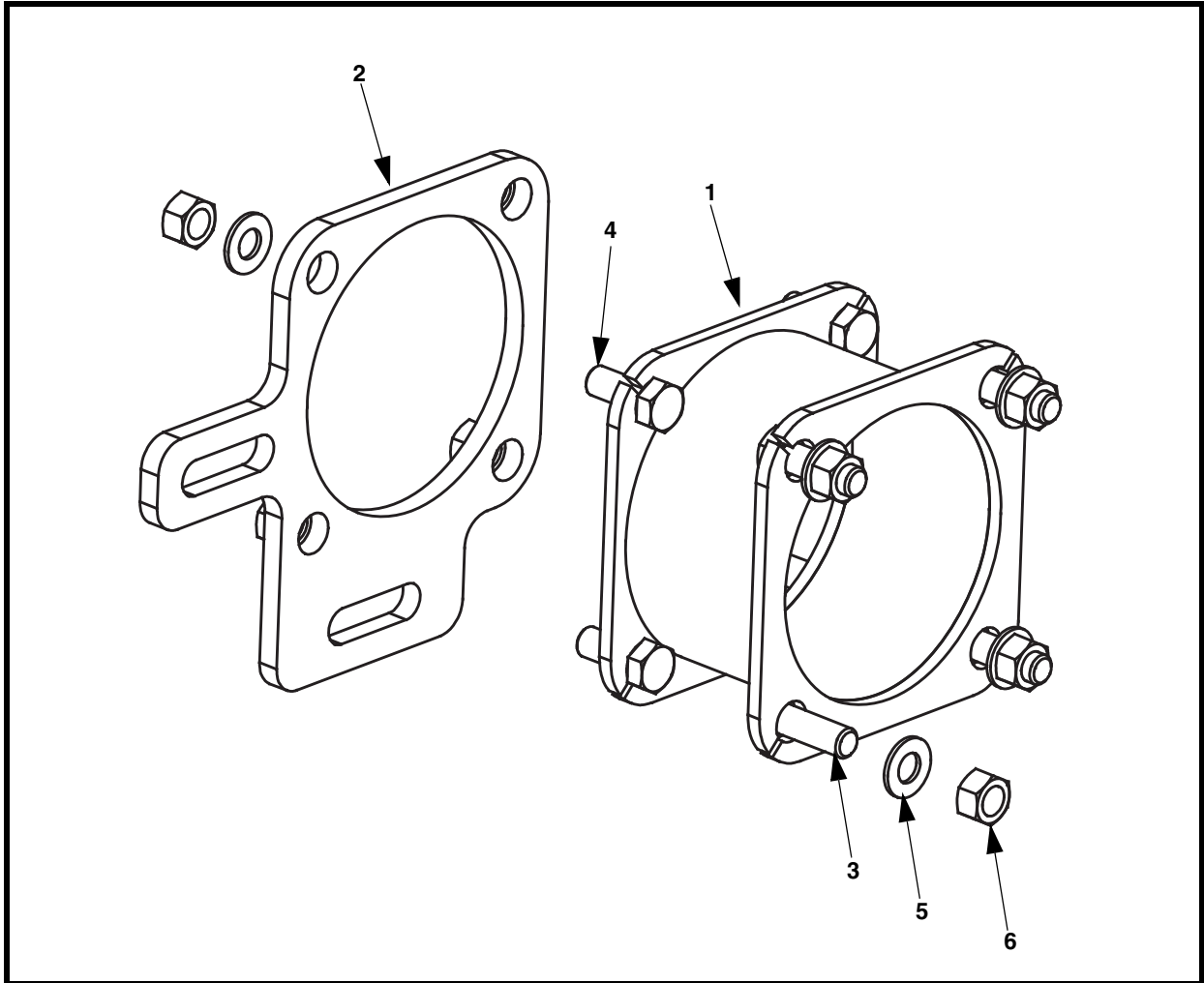

Figure 8. Martin® "L" Bracket Tensioner Mounting Kit, P/N 38844

Item	Description	Part No.	Qty
1	Adapter Weldment	33683	1
2	"L" Bracket	33706	1
3	Screw HHC 1/2-13NC x 1-1/2 ZP	11763	4
4	Screw HHC 1/2-13NC x 1-1/4 ZP	13835	4
5	Washer Compression 1/2	11750	8
6	Nut Hex 1/2-13NC ZP	11771	8

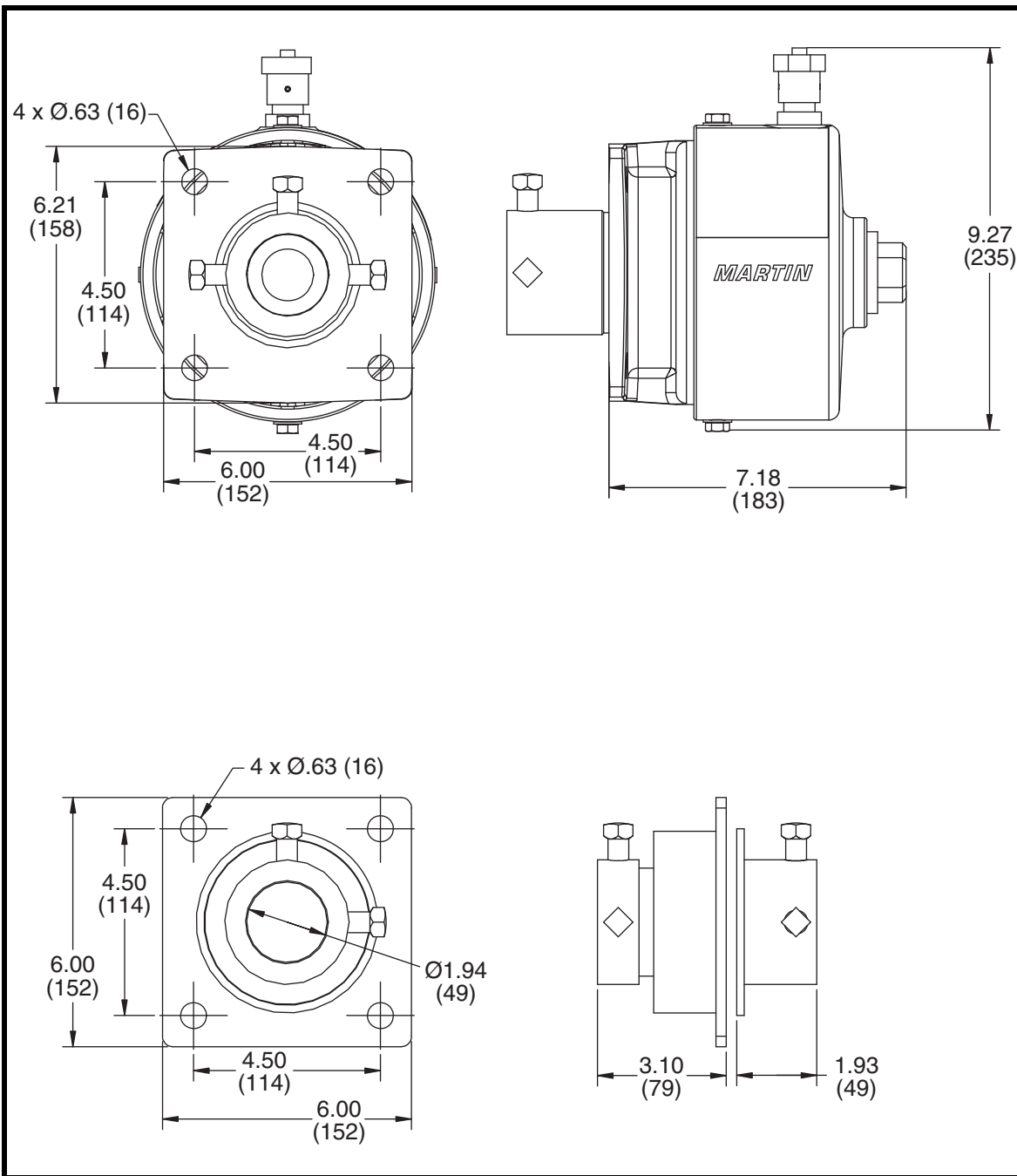

Figure 9. Martin® Twist Tensioner Dimensions

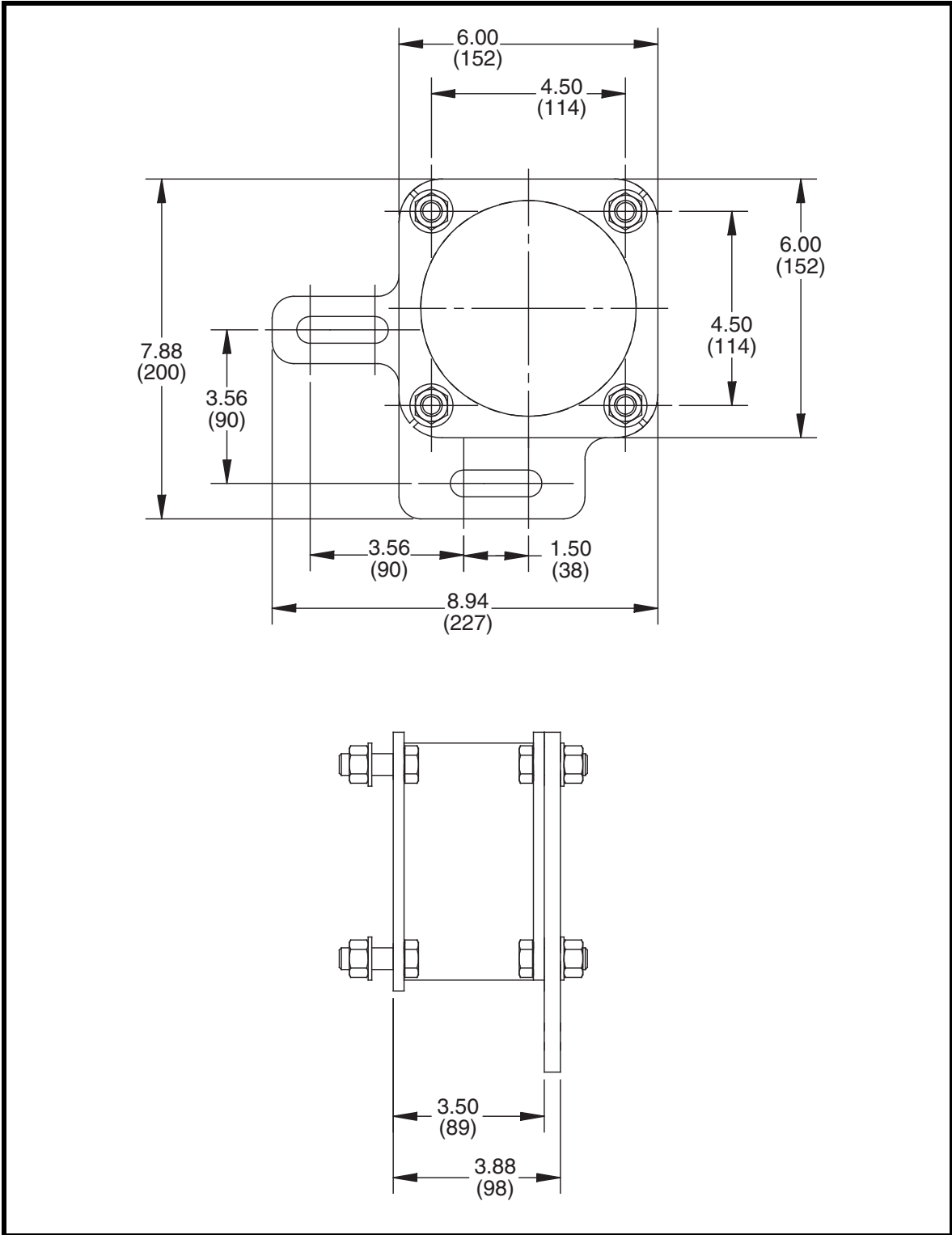

Figure 10. Martin® "L" Bracket Dimensions

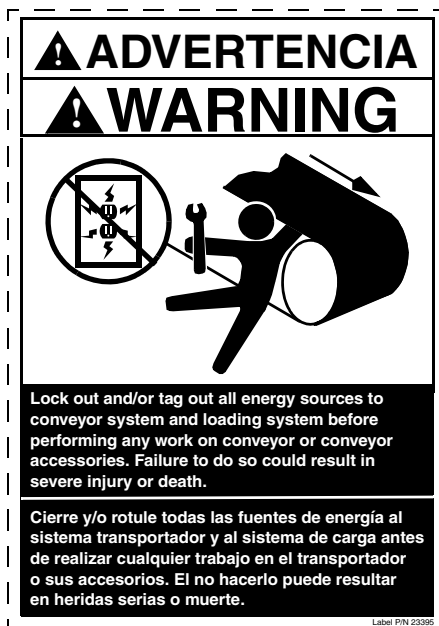

Figure 11. Conveyor Products Warning Label, P/N 23395



Figure 12. Pinch Point Warning Label, P/N 30528

**Martin® Twist Tensioner
Recommended Tension**

Belt width in. (mm)	Number of notches			
	Martin® QC1™ Cleaner HD	Durt Hawg® DH2 Cleaner	Martin® PV Cleaner	Martin® QC1™ Cleaner Metal Tipped
18 (400-500)	2	2	3	1
24 (500-650)	3	3	4	1
30 (650-800)	3	3	4	1
36 (800-1000)	4	4	4	1
42 (1000-1200)	5	5	5	1
48 (1200-1400)	6	6	5	1
54 (1400-1600)	3*	3*	4*	1*
60 (1600-1800)	4*	4*	4*	1*
72 (1800-2000)	5*	5*	5*	1*
84 (2000-2200)	5*	5*	5*	1*
96 (2200-2400)	6*	6*	6*	1*

* Per tensioner; dual tensioners required.

Patents issued and pending Label P/N 33383

**800-544-2947
or 309-852-2384
www.martin-eng.com**

martin®

Figure 13. Martin® Twist Tensioner Label, P/N 33383

Any product, process, or technology described here may be the subject of intellectual property rights reserved by Martin Engineering Company. Trademarks or service marks designated with the ® symbol are registered with the U.S. Patent and Trademark Office and may be proprietary in one or more countries or regions. Other trademarks and service marks belonging to Martin Engineering Company in the United States and/or other countries or regions may be designated with the “TM” and “SM” symbols. Brands, trademarks, and names of other parties, who may or may not be affiliated with, connected to, or endorsed by Martin Engineering Company, are identified wherever possible. Additional information regarding Martin Engineering Company’s intellectual property can be obtained at www.martin-eng.com/trademarks.

Problem Solved™ GUARANTEED!

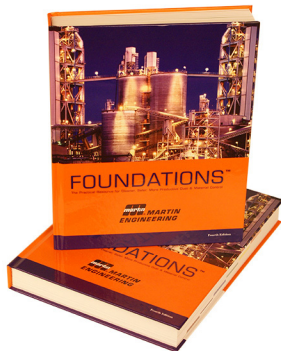

For nearly 20 years, Martin Engineering's Foundations™ Books have taught industry personnel to operate and maintain clean and safe belt conveyors. The Foundations™ Book, fourth edition, focuses on improving belt conveyors by controlling fugitive material. "The Practical Resource for Total Dust and Material Control," is a 576-page hard cover volume that provides information of value to industries where the efficient handling of bulk materials is a key to productivity and profitability.

Expanding upon the book, our Foundations™ Training Program addresses the design and development of more productive belt conveyors, and is offered in three customizable seminars. Attendees gain a better understanding of conveyor safety and performance, helping to justify upgrade investments and increase profitability.



Martin Engineering Australia Pty Ltd.
20 Ern Harley Dr - Burleigh Heads, QLD, 4220 - Australia
1300 627 364
www.martin-eng.com.au

