

martin®

Martin® ***Food Grade
Cleaner and Tensioners***



***Operator's Manual
M3215***

Important

MARTIN ENGINEERING HEREBY DISCLAIMS ANY LIABILITY FOR: DAMAGE DUE TO CONTAMINATION OF THE MATERIAL; USER'S FAILURE TO INSPECT, MAINTAIN AND TAKE REASONABLE CARE OF THE EQUIPMENT; INJURIES OR DAMAGE RESULTING FROM USE OR APPLICATION OF THIS PRODUCT CONTRARY TO INSTRUCTIONS AND SPECIFICATIONS CONTAINED HEREIN. MARTIN ENGINEERING'S LIABILITY SHALL BE LIMITED TO REPAIR OR REPLACEMENT OF EQUIPMENT SHOWN TO BE DEFECTIVE.

Observe all safety rules given herein along with owner and Government standards and regulations. Know and understand lockout/tagout procedures as defined by American National Standards Institute (ANSI) z244.1-1982, *American National Standard for Personnel Protection - Lockout/Tagout of Energy Sources - Minimum Safety Requirements* and Occupational Safety and Health Administration (OSHA) Federal Register, Part IV, 29 CFR Part 1910, *Control of Hazardous Energy Source (Lockout/Tagout); Final Rule*.

The following symbols may be used in this manual:



Danger: Immediate hazards that will result in severe personal injury or death.



Warning: Hazards or unsafe practices that could result in personal injury.



Caution: Hazards or unsafe practices that could result in product or property damages.



Important: Instructions that must be followed to ensure proper installation/operation of equipment.



Note: General statements to assist the reader.

Table of Contents

Section	Page
List of Figures	ii
List of Tables	ii
Introduction	1
General—Belt Cleaner	1
General—Tensioners	1
Installations without chutework	1
Belt cleaner inspection access	2
Belts wider than 48 in. (1400 mm)	2
Blade materials	2
References	2
Safety	2
Materials required	2
Before Installing Belt Cleaner and Tensioner	3
Installing Belt Cleaner and Tensioner	4
Finding center point of Pre-Cleaner mainframe	4
Finding center point of Secondary Cleaner mainframe	5
Installing mounting plates	6
Installing Air Tensioner	8
Installing Hub Mount Tensioner	9
Installing Internal Spring Tensioner	11
After Installing Belt Cleaner and Tensioner	12
Maintenance	14
Weekly maintenance	14
Replacing bumper strips	15
Troubleshooting/Installation Checklist	16
Part Numbers	17
Appendix A. Typical Martin [®] Food Grade Cleaner Installations	A-1
Appendix B. Typical Electrical and Pneumatic Schematics for Martin [®] Food Grade Cleaner Reversing Belt Application	B-1

List of Figures

Figure	Title	Page
1	Pre-Cleaner Mainframe Location	4
2	Secondary Cleaner Mainframe Location	5
3	Internal Spring Tensioner Mounting Plate Installation.	6
4	Hub Mount Tensioner Installation	7
5	Air Tensioner Installation	8
6	Pressure Regulator Installation	9
7	Internal Spring Tensioner Installation.	11
8	Secondary Cleaner Changing Belt Line and With Belt Support.	13
9	Martin [®] Food Grade Cleaner Assembly, P/N 33035-XXX	18
10	Martin [®] Food Grade Cleaner Assembly, P/N 31369-XXX	19
11	Martin [®] Air Tensioner Assembly, P/N 31348-XXX	20
12	Martin [®] Hub Mount Tensioner Assembly, P/N 31368-XXX.	22
13	Martin [®] Internal Spring Tensioner Assembly, P/N 33036-P	23
14	Martin [®] Food Grade Cleaner Pressure/Warning Tag, P/N 31391	24
15	Martin [®] Food Grade Cleaner Torque/Warning Tag, P/N 33298.	25
16	Conveyor Products Warning Label, P/N 23395	26

List of Tables

Table	Title	Page
I	Martin [®] Food Grade Cleaner Specifications	2
II	Martin [®] Air Tensioner Recommended Pressure.	10
III	Martin [®] Hub Mount and Internal Spring Tensioners Recommended Torque . .	10
IV	Martin [®] Food Grade Cleaner Materials	18
V	Martin [®] Food Grade Cleaner Part Numbers and Quantities.	18
VI	Martin [®] Food Grade Cleaner Materials	19
VII	Martin [®] Food Grade Cleaner Part Numbers and Quantities.	19
VIII	Martin [®] Hub Mount Tensioner Part Numbers	22

Introduction

General—Belt Cleaner

The Martin[®] Food Grade Cleaner is a light-duty cleaner designed to remove sticky materials from conveyor belts. This prevents material from gumming rollers, contaminating conveyor belts, or dropping off onto the ground. The Martin[®] Food Grade Cleaner is a dual cleaner system consisting of a Pre-Cleaner and a Secondary Cleaner. For certain applications, either blade can be used alone as a single cleaner system. (See Appendix A for an example of a typical Martin[®] Food Grade Cleaner installation.)

If the material-handling process or product could be affected by contamination from the use of these belt cleaners, the user is responsible for taking the necessary steps to prevent contamination. Consult Martin Engineering or a representative for alternate belt cleaners or belt cleaner locations to use where contamination may be an issue.

Both the Pre-Cleaner and Secondary Cleaner blades are made of materials that meet Federal Drug Administration (FDA) requirements for food processing, preparation, and packaging (21 CFR 175.105, 177.1350, 177.1500, and 177.1520). The United States Department of Agriculture (USDA) Food Safety and Inspection Service (FSIS) has reviewed, tested, and accepted the Martin[®] Food Grade Cleaner System. (Refer to “Equipment: Dual Martin[®] Food Grade Cleaner System,” FSIS directive 11220.1, “Accepted Meat and Poultry Equipment.”)

General— Tensioners

Martin[®] Air Tensioner. This tensioner uses an air cylinder to supply constant and metered pressure to maintain cleaning pressure against the conveyor belt. The Air Tensioner can be used with the Martin[®] Food Grade Cleaner. If used on a reversing conveyor belt, the secondary cleaner must be plumbed to release air from the tensioner and disengage the blades from the belt. (See Appendix A for an example of a typical Martin[®] Air Tensioner installation. See Appendix B for typical electrical and pneumatic schematics for reversing belt applications.)

Martin[®] Hub Mount Tensioner. This tensioner is tightened and locked into position to supply cleaning pressure against the conveyor belt. The Hub Mount Tensioner can be used with the Martin[®] Food Grade Cleaner, but should not be used on reversing belts. (See Appendix A for an example of a typical Martin[®] Hub Mount Tensioner installation.)

Martin[®] Internal Spring Tensioner. This tensioner uses a tensioner spring that is tightened and locked into position to supply cleaning pressure against the conveyor belt. The Internal Spring Tensioner can be used with the Martin[®] Food Grade Cleaner, but should not be used on reversing belts. (See Appendix A for an example of a typical Martin[®] Internal Spring Tensioner installation.)

Installations without chutework

These procedures were written for equipment that is being installed on enclosed pulley chutework. If the pulley is not enclosed, the equipment should be installed using the best available field resources and methods to ensure that the critical dimensions are followed for proper installation.

Belt cleaner inspection access

If the belt cleaner is installed on enclosed pulley chutework, a Martin[®] Inspection Door should be installed. Food-grade Martin[®] Inspection Doors are available from Martin Engineering or your representative.

Belts wider than 48 in. (1400 mm)

If the Martin[®] Food Grade Secondary Cleaner will be installed on a belt wider than 48 in. (1400 mm), a center bracket (P/N 31921) must be installed. Contact Martin Engineering or representative for installation instructions.

Blade materials

Martin[®] Food Grade Cleaner blades are constructed of food-grade plastics, stainless steel, and aluminum. Table I shows the particular specifications for the Martin[®] Food Grade Cleaner blades.

Table I. Martin[®] Food Grade Cleaner Specifications

Specifications	Pre-Cleaner		Secondary Cleaner		
	LDPE	Nylon	HDPE	Nylon	Aluminum
*Materials Used	LDPE	Nylon	HDPE	Nylon	Aluminum
Temperature Limits	-20 to 140°F -29 to 60°C	-40 to 380°F -40 to 193°C	-20 to 160°F -29 to 71°C	-40 to 380°F -40 to 193°C	-40 to 400°F -40 to 205°C
Maximum Belt Speed	200 fpm 1 m/s	350 fpm 2 m/s	250 fpm 1.25 m/s	350 fpm 2 m/s	300 fpm 1.50 m/s
*LDPE = Low-density polyethylene; HDPE = High-density polyethylene					

References

The following documents are referenced in this manual:

- American National Standards Institute (ANSI) z244.1-1982, *American National Standard for Personnel Protection - Lockout/Tagout of Energy Sources - Minimum Safety Requirements*, American National Standards Institute, Inc., 1430 Broadway, New York, NY 10018.
- Federal Register, Volume 54, Number 169, Part IV, 29 CFR Part 1910, *Control of Hazardous Energy Source (Lockout/Tagout); Final Rule*, Department of Labor, Occupational Safety and Health Administration (OSHA), 32nd Floor, Room 3244, 230 South Dearborn Street, Chicago, IL 60604.
- *Martin[®] Inspection Door Operator's Manual*, P/N M3891.

Safety

All safety rules defined in the above documents and all owner/employer safety rules must be strictly followed when working on the belt cleaner.

Materials required

Only standard hand tools are required to install and service this equipment.

Before Installing Belt Cleaner and Tensioner

IMPORTANT

The delivery service is responsible for damage occurring in transit. Martin Engineering CANNOT enter claims for damages. Contact your transportation agent for more information.

1. Inspect shipping container for damage. Report damage to delivery service immediately and fill out delivery service's claim form. Keep any damaged goods subject to examination.
2. Remove belt cleaner and tensioner from shipping container.
3. If anything is missing, contact Martin Engineering or representative.



WARNING

Before installing equipment, turn off and lock out/tag out energy source to conveyor and conveyor accessories.

4. Turn off and lock out/tag out energy source according to ANSI standards (see "References").

WARNING

If equipment will be installed in an enclosed area, gas level or dust content must be tested before using a cutting torch or welding. Using a cutting torch or welding in an area with gas or dust may cause an explosion.

5. If using a cutting torch or welding, test atmosphere for gas level or dust content. Cover conveyor belt with fire retardant cover.

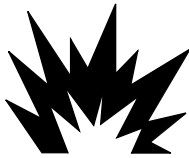

NOTE

The chute wall that the tensioner will be located on is referred to as the "operator side." The other side of the chute is referred to as the "far side."

6. Determine which side of chute wall is easiest to access. Locate tensioner on most accessible chute wall.

Installing Belt Cleaner and Tensioner

IMPORTANT

Read entire section before beginning work.

To install the belt cleaner, follow the procedures corresponding to the following steps:

1. Find center point of belt cleaner mainframe (Pre-Cleaner and Secondary Cleaner).
2. Install tensioner (Air Tensioner, Hub Mount Tensioner, or Internal Spring Tensioner).

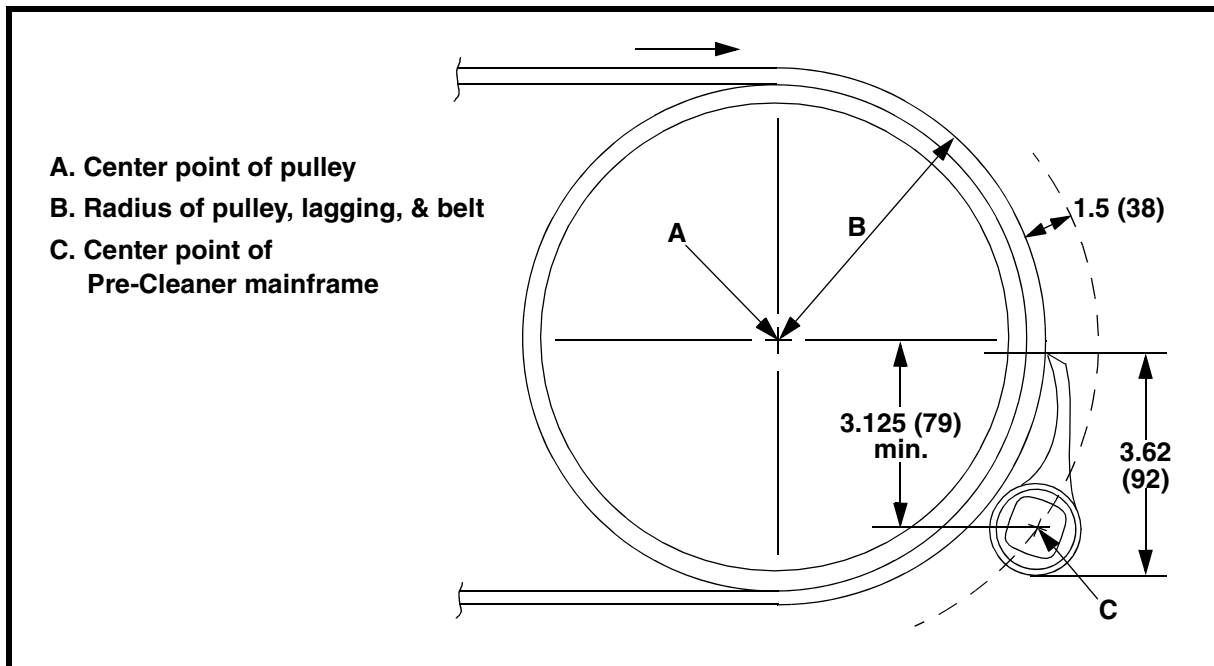

Figure 1. Pre-Cleaner Mainframe Location

Finding center point of Pre-Cleaner mainframe

1. See Figure 1. On operator side chute wall, mark vertical and horizontal center line of head pulley to find pulley center point (A).
2. Measure radius of head pulley including lagging and belt thickness (B). To this measurement, add $1\text{-}1/2 \pm 1/8$ in. (38 ± 3 mm).
3. Starting from point (A), measure the total distance calculated in step 2 and draw an arc on chute wall.
4. Measure down a minimum of $3\text{-}1/8$ in. (79 mm) from pulley's horizontal center line. Draw a horizontal line parallel to pulley's horizontal center line. Locate center point of Pre-Cleaner mainframe (C) where this horizontal line intersects arc on chute wall.
5. It is recommended to keep the blades and mainframe out of the material flow path to allow for proper belt cleaning and blade life. Make sure blade tip is at or below horizontal center line of pulley.
6. Repeat steps 1 through 5 for far side chute wall.
7. If using Martin[®] Inspection Door, install according to *Martin[®] Inspection Door Operator's Manual*, P/N M3891.

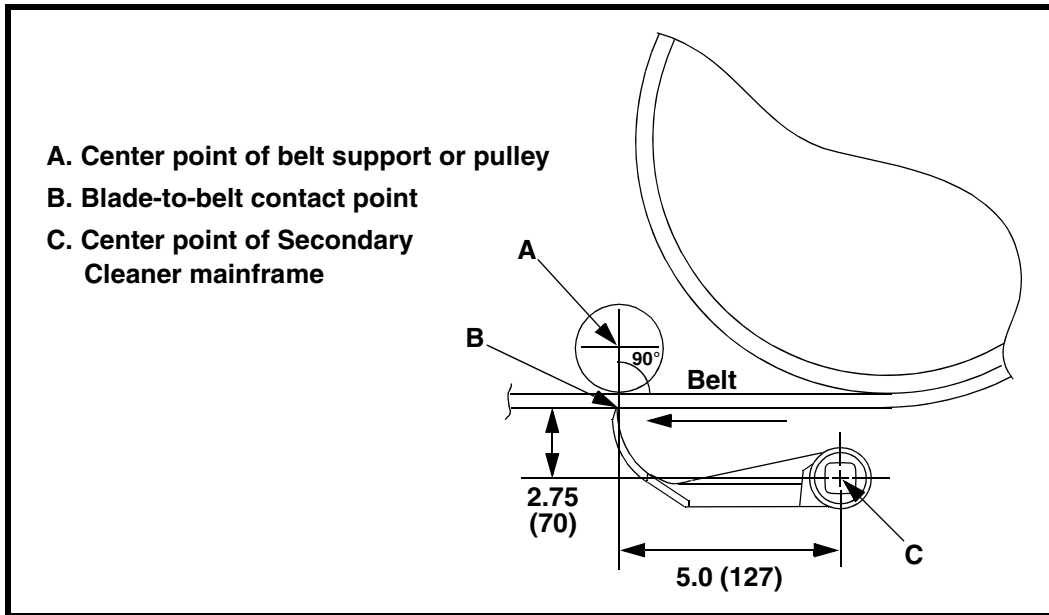

Figure 2. Secondary Cleaner Mainframe Location

Finding center point of Secondary Cleaner mainframe

1. See Figure 2. On operator side chute wall, mark vertical and horizontal center line of pulley or belt support to find center point (A). Make sure vertical center line is perpendicular to belt line.
2. Locate blades where this line crosses bottom (return side) of conveyor belt: blade-to-belt contact point (B). (If belt is not adequately supported, a belt support must be installed. See step 4 under “After Installing Belt Cleaner.”)
3. Starting from point (B), measure vertically and horizontally as shown in Figure 2. Mark center point of Secondary Cleaner mainframe (C) on chute wall.
4. Repeat steps 1 through 3 for far side chute wall.
5. If using Martin[®] Inspection Door, install according to *Martin[®] Inspection Door Operator’s Manual*, P/N M3891.

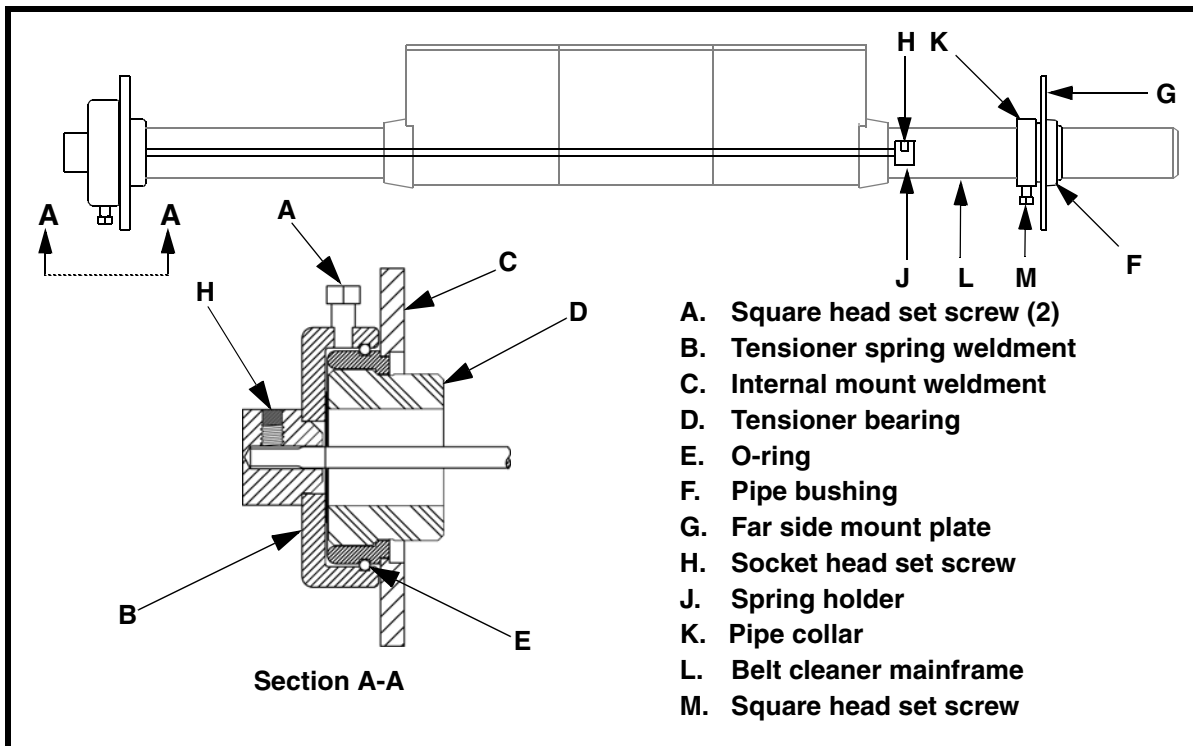

Figure 3. Internal Spring Tensioner Mounting Plate Installation

Installing mounting plates

1. For Internal Spring Tensioner (Figure 3), do the following:
 - a. Loosen two square head set screws (A) on tensioner spring weldment (B).
2. Using a screwdriver, pry tensioner spring weldment (B) off internal mount weldment (C). (Tensioner bearing (D) and O-ring (E) should be on internal mount weldment.)
3. For all tensioners, use center points of Pre-Cleaner (C, Figure 1) and Secondary Cleaner (C, Figure 2) mainframes to mark location of holes for mounting plates. Use tensioner mounting plates as templates.

NOTE

For easier maintenance, Martin Engineering recommends bolting rather than welding tensioners to chute walls.

4. Bolt or weld mounting plates to chute walls as follows:
 - a. If using a cutting torch or welding, test atmosphere for gas level or dust content. Cover conveyor belt with fire retardant cover.
 - b. If bolting mounting plates to chute walls, do the following:
 - (1) Drill or cut mounting holes as follows:
 - (a) Four 7/16-in. (11-mm) holes for screws in both operator side and far side chute walls.
 - (b) One 2-1/8-in. (54-mm) hole for mainframe in operator side chute wall.
 - (c) One 1-3/4-in. (44-mm) hole for mainframe in far side chute wall.
 - (2) Remove burrs and sharp edges.

- (3) Install each mounting plate onto outside chute wall with four hex head cap screws, flat washers, compression washers, and hex nuts.
- c. If welding mounting plates to chute walls, do the following:
 - (1) Drill or cut one 2-1/8-in. (54-mm) mainframe hole in operator side chute wall, and one 1-3/4-in. (44-mm) mainframe hole in far side chute wall. Remove burrs and sharp edges.
 - (2) For Hub Mount Tensioner (Figure 4), loosen two set screws (A) on hub mount weldment (B), and remove sleeve (C). Remove pipe bushing (D) from far side mount plate (E). Use a mallet to pound off the pipe bushing.

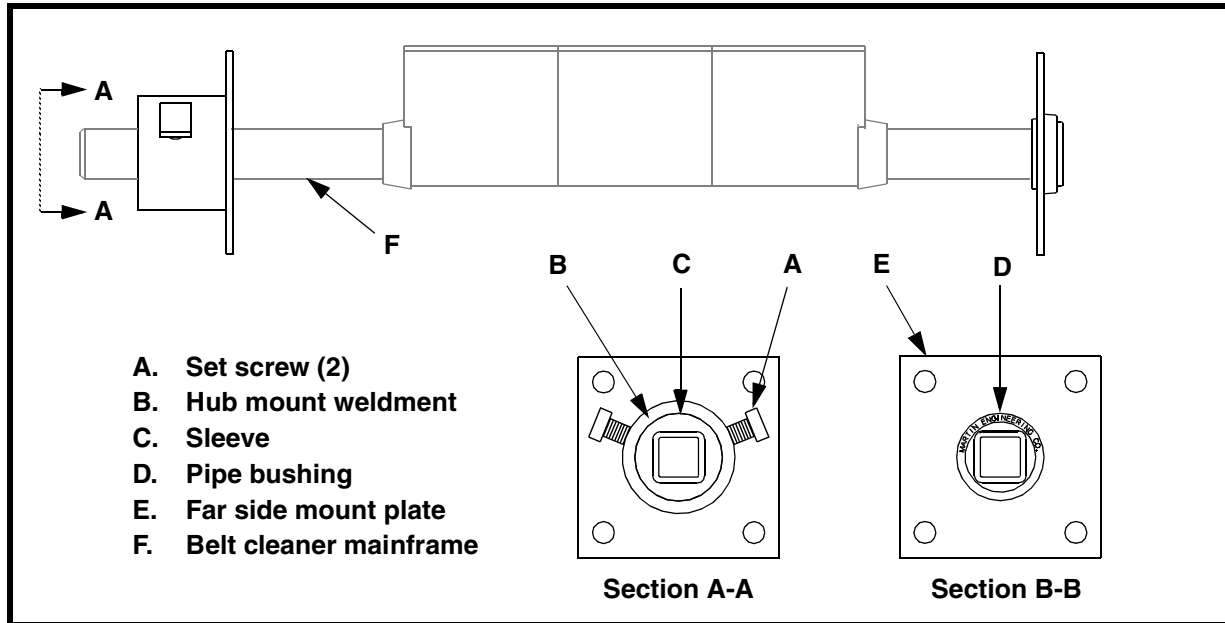

Figure 4. Hub Mount Tensioner Installation

- (3) For Internal Spring Tensioner (Figure 4), remove tensioner bearing (D) and O-ring (E) from internal mount weldment (C). Remove pipe bushing (F) from far side mount plate (G). Use a mallet to pound off the tensioner bearing and pipe bushing.
 - (4) Position each mounting plate over hole, and weld onto wall. Make continuous weld around entire mounting plate.
 - (5) For Hub Mount Tensioner (Figure 4), push sleeve (C) into hub mount weldment (B). Snap pipe bushing (D) into far side mount plate (E).
 - (6) For Internal Spring Tensioner (Figure 3), install tensioner bearing (D) and O-ring (E) onto internal mount weldment (C).
4. To install tensioners, go to the appropriate section in this manual for the Martin[®] Air Tensioner, Hub Mount Tensioner, or Internal Spring Tensioner.

Installing Air Tensioner

IMPORTANT

If installing Pre-Cleaner or Secondary Cleaner with Air Tensioner on reversing conveyor belt, a cleaner and tensioner must be installed on head pulley and tail pulley. If using Secondary Cleaner on reversing belt, cleaner must be plumbed to disengage when belt reverses, as shown in Appendix B. (See Appendix A for correct Air Tensioner orientation.)

1. Push down on tensioning arm weldment (A, Figure 5) until piston rod (B) is all the way inside air cylinder (C).

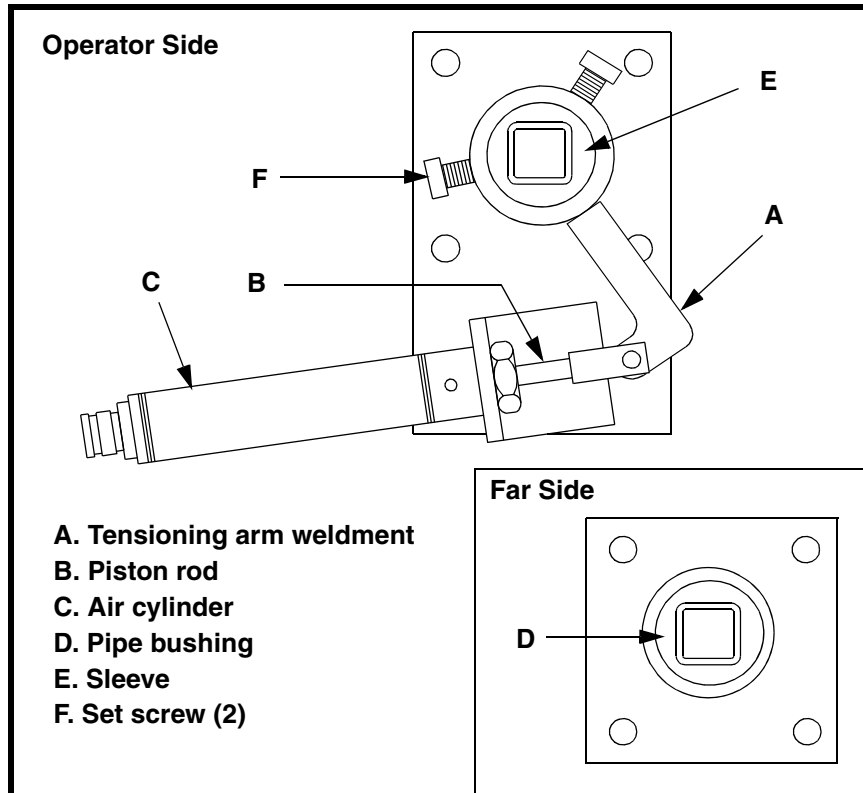

Figure 5. Air Tensioner Installation

2. Insert belt cleaner assembly into pipe bushing (D) in far side mounting plate, then into sleeve (E) in operator side mounting plate.
3. Center the blades on belt. Measure from center point of pulley to outside edge of first and last blade to make sure blades are centered.
4. While holding piston rod (B, Figure 5) inside air cylinder (C), grasp belt cleaner mainframe and turn it until blades are touching conveyor belt.
5. Tighten two set screws (F) in tensioning arm weldment (A).

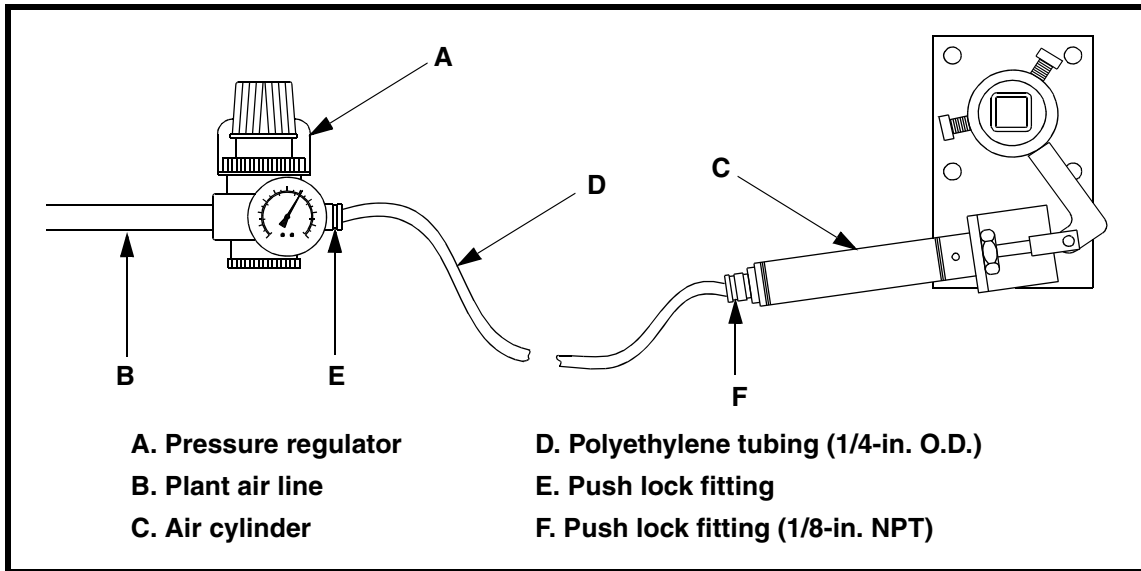

Figure 6. Pressure Regulator Installation

6. Install pressure regulator (A, Figure 6), as follows:
 - a. Install pressure regulator onto your plant air line (B) as shown.
 - b. Measure distance between pressure regulator (A) and air cylinder (C). Cut this length of polyethylene tubing (D) plus enough slack for air cylinder to pivot freely.
 - c. Push one end of polyethylene tubing (D) into push lock fitting (E) on regulator. Push the other end into push lock fitting (F) on air cylinder. (You should feel the tubing snap into the fittings.)
 - d. Check all fittings for air leaks.
7. Apply pressure to tensioner according to Table II.

Installing Hub Mount Tensioner

1. Insert belt cleaner assembly into pipe bushing (D, Figure 4) in far side mount plate (E), then into sleeve (C) in hub mount weldment (B).
2. Center the blades on belt. Measure from center point of pulley to outside edge of first and last blade to make sure blades are centered.
3. Turn belt cleaner mainframe (F, Figure 4) until blades are touching belt. Tighten hub according to Table III.
4. Tighten two set screws (A) on hub mount weldment (B).

Table II. Martin® Air Tensioner Recommended Pressure

Blade Coverage in. (mm)	Number of Blades	Recommended Pressure—psi (bar)				
		Pre-Cleaner**			Secondary**	
		P	U	N	P	N,A
4 (102)	1	4 (.28)	2 (.14)	7 (.48)	5 (.34)	8 (.55)
8 (203)	2	7 (.48)	4 (.28)	14 (.97)	10 (.69)	16 (1.10)
12 (305)	3	11 (.76)	5 (.34)	21 (1.45)	15 (1.03)	24 (1.65)
16 (406)	4	14 (.97)	7 (.48)	28 (1.93)	20 (1.38)	32 (2.21)
24 (609)	6	21 (1.45)	11 (.76)	42 (2.90)	29 (2.00)	48 (3.31)
28 (711)	7	25 (1.72)	12 (.83)	49 (3.38)	34 (2.34)	56 (3.86)
36 (914)	9	32 (2.21)	16 (1.10)	63 (4.34)	44 (3.03)	36 (2.48)*
40 (1016)	10	35 (2.34)	18 (1.24)	70 (4.83)	49 (3.38)	40 (2.76)*
48 (1219)	12	42 (2.90)	21 (1.45)	42 (2.90)*	59 (4.06)	48 (3.31)*
56 (1422)	14	49 (3.38)	25 (1.72)	49 (3.38)*	61 (4.21)*	56 (3.86)*
64 (1626)	16	56 (3.86)	28 (1.93)	56 (3.86)*	64 (4.41)*	60 (4.14)*

*Pressure per side. Dual tensioners required.
 **P = low- or high-density polyethylene; U = linear low-density polyethylene;
 N = nylon; A = aluminum

Table III. Martin® Hub Mount and Internal Spring Tensioners Recommended Torque

Blade Coverage in. (mm)	Number of Blades	Recommended Torque—in.-lb (Nm)				
		Pre-Cleaner**			Secondary**	
		P	U	N	P	N,A
4 (102)	1	2 (.23)	1 (.11)	3 (.34)	3 (.34)	5 (.57)
8 (203)	2	3 (.34)	1.5 (.17)	6 (.68)	4 (.45)	10 (1.1)
12 (305)	3	4 (.45)	2 (.23)	8 (.90)	6 (.68)	15 (1.7)
16 (406)	4	6 (.68)	3 (.34)	11 (1.2)	11 (1.2)	20 (2.3)
24 (609)	6	8 (.90)	4 (.45)	17 (1.9)	17 (1.9)	15 (1.7)*
28 (711)	7	10 (1.1)	5 (.57)	19 (2.1)	20 (2.3)	18 (2.0)*
36 (914)	9	12 (1.4)	6 (.68)	13 (1.5)*	13 (1.5)*	23 (2.6)*
40 (1016)	10	14 (1.6)	7 (.79)	14 (1.6)*	14 (1.6)*	***
48 (1219)	12	17 (1.9)	8 (.90)	17 (1.9)*	17 (1.9)*	***
56 (1422)	14	19 (2.1)	10 (1.1)	20 (2.3)*	20 (2.3)*	***
64 (1626)	16	22 (2.5)	11 (1.2)	22 (2.5)*	23 (2.6)*	***

*Pressure per side. Dual tensioners required.
 **P = low- or high-density polyethylene; U = linear low-density polyethylene;
 N = nylon; A = aluminum
 ***Air Tensioners required.

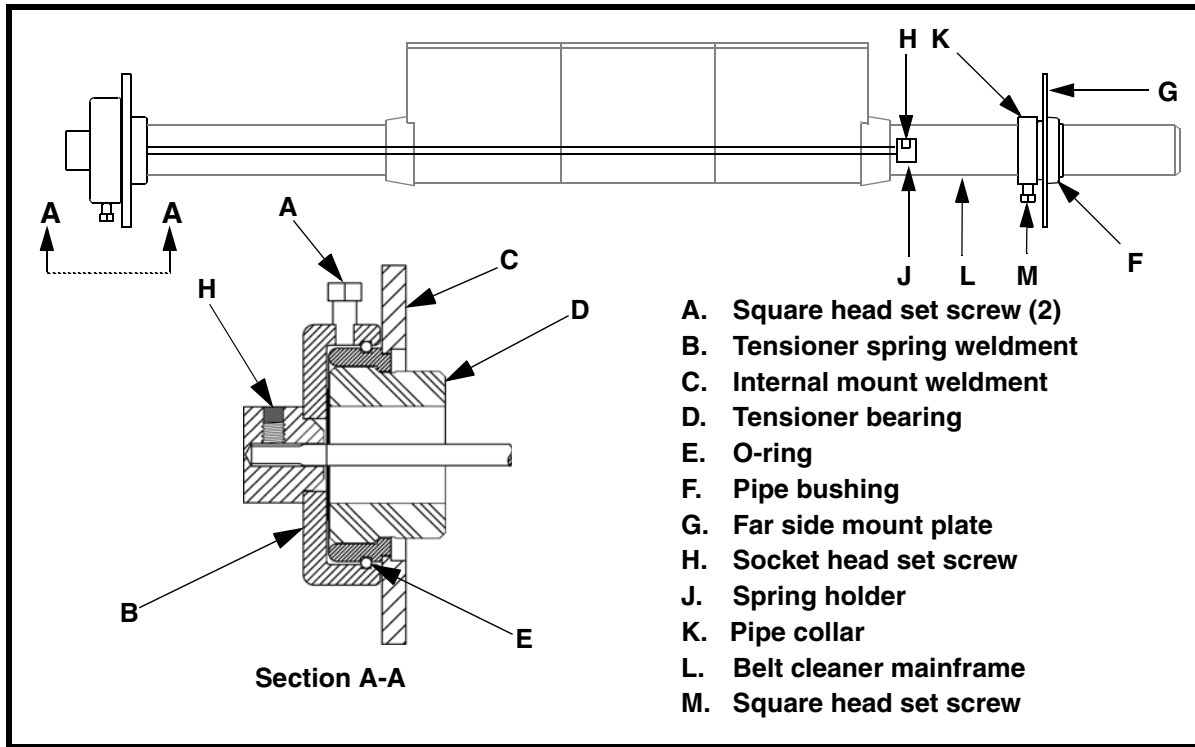

Figure 7. Internal Spring Tensioner Installation

Installing Internal Spring Tensioner

1. If mainframe is longer than 16 in. (406 mm), go to step 2. If mainframe is 16 in. (406 mm) long, do the following:
 - a. Remove socket head set screw (H) from spring holder (J). Remove spring holder from end of tensioner spring weldment (B).
 - b. Cut tensioner spring weldment to 14-1/2 in. (368 mm) long.
 - c. Install spring holder onto cut end of tensioner spring weldment. Secure with socket head set screw.
2. Snap pipe bushing (F) into hole in far side mount plate (G) as shown.
3. Slide pipe collar (K) onto far side end of belt cleaner mainframe (L).
4. Insert belt cleaner mainframe into pipe bushing (F) in far side mount plate (G), then into tensioner bearing (D) in internal mount weldment (C).
5. Remove end cap (if present) from operator side end of belt cleaner mainframe (L).
6. Insert tensioner spring weldment (B), spring holder (J) end first, into mainframe.
7. Press tensioner spring weldment against internal mount weldment (C) until it snaps securely into place.
8. Center the blades on belt. Measure from center point of pulley to outside edge of first and last blade to make sure blades are centered.
9. Slide pipe collar (K) against far side mount plate (G), and tighten square head set screw (M).
10. Turn belt cleaner mainframe (L) until blades are touching belt. Then tighten tensioner spring weldment (B) according to Table III.

After Installing Belt Cleaner and Tensioner

IMPORTANT

Read entire section before beginning work.

1. After you have installed belt cleaner and tensioner, measure from pulley shaft to mainframe, on both operator side and far side, to make sure mainframe is parallel to pulley.
2. Measure from center point of end of mainframe to face of conveyor belt to make sure the proper critical dimension is held. (See Figures 1 and 2.)
3. Measure from center point of pulley to outside edge of first and last blade to make sure blades are centered on belt.
4. For all tensioners, thoroughly wipe chute wall clean above belt cleaner on operator side. Place Conveyor Products Warning Label (P/N 23395) on outside chute wall visible to belt cleaner operator.
5. For Air Tensioner, attach Pressure/Warning Labels (P/N 31391) to air line with nylon cable tie. For Hub Mount and Internal Spring Tensioners, attach Torque/Warning Labels (P/N 33298) to stringer with nylon cable tie.

▲ WARNING

Failure to remove tools from installation area and conveyor belt before turning on energy source can cause serious injury to personnel and damage to belt.

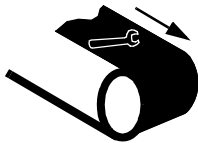

6. Remove all tools and fire retardant cover from installation area and conveyor belt.

▲ DANGER

Do not touch or go near conveyor belt or conveyor accessories when conveyor belt is running. Body or clothing can get caught and pull body into conveyor belt, causing severe injury or death.



7. Turn on conveyor belt for 1 hour.

▲ WARNING

Before adjusting belt cleaner, turn off and lock out/tag out energy source to conveyor belt and conveyor accessories.



8. After 1 hour of operation, turn off and lock out/tag out energy source according to ANSI standards (see “References”).
9. Make sure all fasteners are tight. Tighten if necessary.
10. Inspect belt cleaner for the following:
 - Wear. (A small amount of “break-in” wear may be found. This will stop once blades wear to conveyor belt contour.)
 - Material buildup. (No material between blades and return side of conveyor belt should be found.)

11. If wear or material buildup exists, see “Troubleshooting/Installation Checklist.”
12. Make sure Secondary Cleaner is not changing conveyor belt line (see Figure 8). If cleaner is changing belt line, perform steps 12.a and 12.b. If belt line is straight, go to step 13.

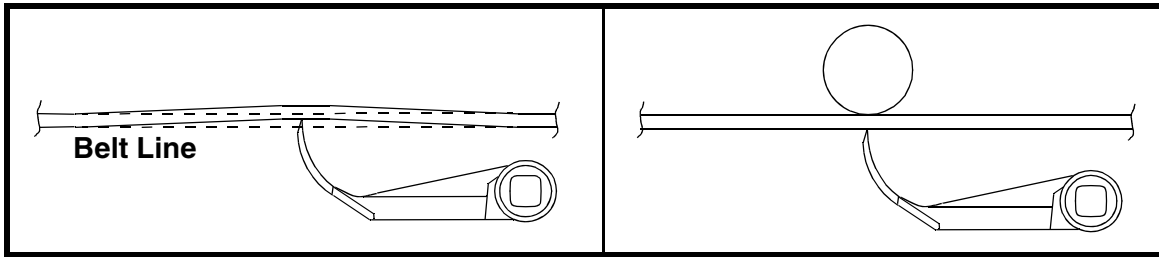

Figure 8. Secondary Cleaner Changing Belt Line and With Belt Support



▲ WARNING

Before adjusting belt cleaner, turn off and lock out/tag out energy source to conveyor belt and conveyor accessories.

- a. Turn off and lock out/tag out energy source according to ANSI standards (see “References”).
 - b. Install belt support directly above blade-to-belt contact point (B, Figure 2).
13. Repeat step 5.

▲ DANGER

Do not touch or go near conveyor belt or conveyor accessories when conveyor belt is running. Body or clothing can get caught and pull body into conveyor belt, causing severe injury or death.



14. Restart conveyor belt.

Maintenance

NOTE

Maintenance inspection should be performed no less than weekly. Your application may require more frequent maintenance inspections.

IMPORTANT

Read entire section before beginning work.



⚠ WARNING

Before servicing belt cleaner, turn off and lock out/tag out energy source to conveyor belt and conveyor accessories.

1. Turn off and lock out/tag out energy source according to ANSI standards (see “References”).
2. To perform weekly maintenance on belt cleaner and tensioner, see “Weekly maintenance.”
3. To replace bumper strips in aluminum Secondary Cleaner arms, see “Replacing bumper strips.”

Weekly maintenance

1. Make sure all fasteners are tight. Tighten if necessary.
2. Check blades for wear. Allow 1 in. (25 mm) of wear on Pre-Cleaner blades, and 1.5 in. (38 mm) of wear on Secondary Cleaner blades. If blades are worn past these limits, replace as follows:
 - a. Release mainframe from tensioner.
 - b. Remove belt cleaner assembly.
 - c. Slide worn blades off mainframe.
 - d. Slide new blades onto mainframe.
 - e. Re-install belt cleaner according to the appropriate section in this manual for the Martin[®] Air Tensioner, Hub Mount Tensioner, or Internal Spring Tensioner.

NOTE

Remove equipment from service if there is any indication it is not functioning properly. Call Martin Engineering or representative for assistance. Do NOT return equipment to operation until the cause of the problem has been identified and corrected.

3. Wipe all labels clean. If labels are not readable, contact Martin Engineering or representative for replacements.

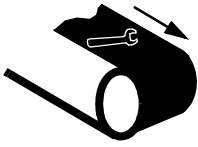

▲ WARNING

Failure to remove tools from installation area and conveyor belt before turning on energy source can cause serious injury to personnel and damage to belt.

4. Remove all tools from maintenance area.

▲ DANGER

Do not touch or go near conveyor belt or conveyor accessories when conveyor belt is running. Body or clothing can get caught and pull body into conveyor belt, causing severe injury or death.

5. Restart conveyor belt.



Replacing bumper strips

1. Release aluminum Secondary Cleaner mainframe from tensioner.
2. Remove aluminum Secondary Cleaner assembly.
3. Slide aluminum blades with worn bumper strips off mainframe.
4. Remove bumper strips from blade arm. (Soaking the arm in soapy water may make removal easier.)

IMPORTANT

Each blade arm should contain two bumper strips which should be side-by-side and in the same location inside all arms on that mainframe.

5. Push new bumper strips into blade arm. (Soaking the bumper strips in soapy water may make installation easier.) Make sure bumper strips are side-by-side and in the same location inside the arm as in the other arms on the mainframe. (See Figure 11, view B-B.)
6. Install aluminum Secondary Cleaner according to the appropriate section in this manual for the Martin[®] Air Tensioner, Hub Mount Tensioner, or Internal Spring Tensioner.

Troubleshooting/Installation Checklist

Troubleshooting

If you are experiencing high blade wear or insufficient cleaning and carryback, see below.

Symptom	Corrective Action
Rapid blade wear.	Tension of cleaner on belt is set too high. Reduce tensioner setting.
Insufficient cleaning and carryback.	<ul style="list-style-type: none"> • Tension of cleaner on belt is set too low or too high. Increase or decrease tensioner setting. • Blades are worn. Check blades and replace if necessary. (See step 2 in the “Maintenance” section.)

NOTE

Conveyor equipment such as conveyor belt cleaners are subject to a wide variety of bulk materials characteristics and often have to perform under extreme operating or environmental conditions. It is not possible to predict all circumstances that may require troubleshooting. Contact Martin Engineering or a representative if you are experiencing problems other than those listed in the “Troubleshooting” chart above. Do not return the equipment to operation until the problem has been identified and corrected.

Installation checklist

If after taking the corrective actions suggested under “Troubleshooting” you are still experiencing problems, check for the following:

Installation Checklist
✓ Distance from center of Pre-Cleaner mainframe to belt surface is 1-1/2 in. (38 mm) on both ends of mainframe.
✓ Distance from center of Secondary Cleaner mainframe to belt surface is 2-3/4 in. (70 mm) on both ends of mainframe.
✓ Pre-Cleaner blade tip is at or below horizontal center line of pulley, and does not lie in path of material flow.
✓ For Pre-Cleaner or Secondary Cleaner with Air Tensioner on reversing belt, a cleaner and tensioner is installed on head pulley and tail pulley. Secondary Cleaner is plumbed to disengage when belt reverses.
✓ Secondary Cleaner is not changing belt line (Figure 8).
✓ Blades are centered on belt.

Part Numbers

Martin® Food Grade Cleaner

This section provides product names and corresponding part numbers for Martin® Food Grade Cleaner and related equipment. Please reference part numbers when ordering parts:

Martin® Food Grade Pre-Cleaner Assembly: P/N 33035-XXX.
See Figure 9.

Martin® Food Grade Pre-Cleaner Assembly (polyethylene) with Internal Spring Tensioner: P/N 33051-XXX.

Martin® Food Grade Secondary Cleaner Assembly (polyethylene and nylon): P/N 31369-XXX. See Figure 10.

Martin® Food Grade Secondary Cleaner Assembly (polyethylene and nylon) with Internal Spring Tensioner: P/N 33480-XXX.

Martin® Tensioners

Martin® Air Tensioner Assembly: P/N 31348-SSP.
See Figure 11.

Martin® Hub Mount Tensioner Assembly: P/N 31368-XXX.
See Figure 12.

Martin® Internal Spring Tensioner Assembly: P/N 33036-P.
See Figure 13.

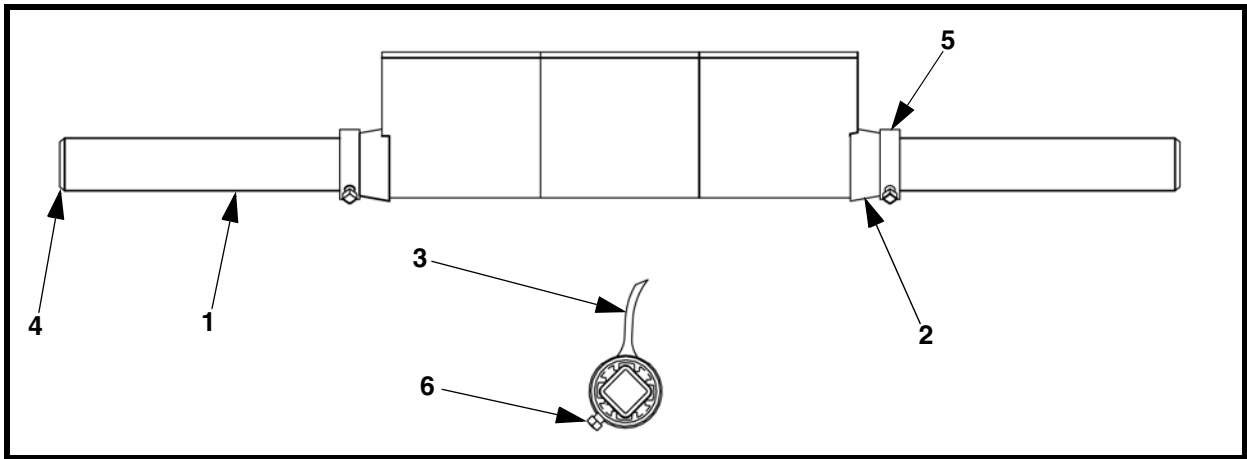

Item	Description	Part No.	Qty
1	Mainframe	Table V	1
2	Pipe Collar	32959-P	2
3	Pre-Cleaner Blade	Table IV	Table V
4	Plastic End Cap	31833	2
5	Pipe Collar	33056	2
6	Screw Set 1/4 -20 x 1/2 SS	24298-04	2

Figure 9. Martin[®] Food Grade Cleaner Assembly, P/N 33035-XXX*

Table IV. Martin[®] Food Grade Cleaner Materials

Assembly Part No.	Material	Item 3 Part No.
33035-XXP	Low-Density Polyethylene	32958-P
33035-XXN	Nylon	32958-N

Table V. Martin[®] Food Grade Cleaner Part Numbers and Quantities

Assembly Part No.	Item 1 Part No.	Item 3 Qty
33035-04X	31350-04	1
33035-06X	31350-04	1
33035-08X	31350-08	2
33035-12X	31350-12	3
33035-18X	31350-18	4
33035-24X	31350-24	6
33035-30X	31350-30	7
33035-36X	31350-36	9
33035-42X	31350-42	10
33035-44X	31350-44	11
33035-48X	31350-48	12
33035-52X	31350-54	13
33035-60X	31350-60	14
33035-66X	31350-72	16
33035-72X	31350-78	18

*First XX indicates belt width in inches; last X indicates material (e.g., 33035-18P is Pre-Cleaner with low-density polyethylene blades for 18-in. wide conveyor belt).

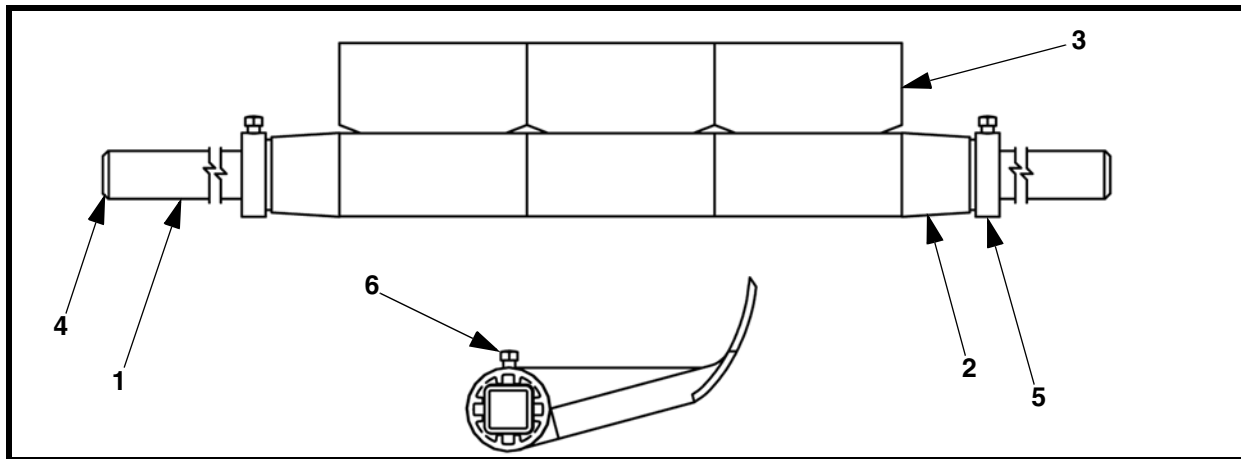

Item	Description	Part No.	Qty
1	Mainframe	Table VII	1
2	Pipe Collar	31901-P	2
3	Secondary Cleaner Blade	Table VI	Table VII
4	Cap Plastic End	31833	2
5	Pipe Collar	33056	2
6	Screw Set 1/4 -20 x 1/2 SS	24298-04	2

**Figure 10. Martin® Food Grade Cleaner Assembly, P/N 31369-XXX*
(high-density polyethylene and nylon only)**

Table VI. Martin® Food Grade Cleaner Materials

Assembly Part No.	Material	Item 3 Part No.
31369-XXP	High-Density Polyethylene	31126-P
31369-XXN	Nylon	31126-N

Table VII. Martin® Food Grade Cleaner Part Numbers and Quantities

Assembly Part No.	Item 1 Part No.	Item 3 Qty.
31369-04X	31350-04	1
31369-06X	31350-04	1
31369-08X	31350-08	2
31369-12X	31350-12	3
31369-18X	31350-18	4
31369-20X	31350-20	5
31369-24X	31350-24	6
31369-30X	31350-30	7
31369-36X	31350-36	9
31369-42X	31350-42	10
31369-44X	31350-44	11
31369-48X	31350-48	12
31369-54X	31350-54	13
31369-60X	31350-60	14
31369-72X	31350-72	17
31369-84X	31350-84	20

*First XX indicates belt width in inches; last X indicates material (e.g., 31369-18P is Secondary Cleaner with high-density polyethylene blades for 18-in. wide conveyor belt).

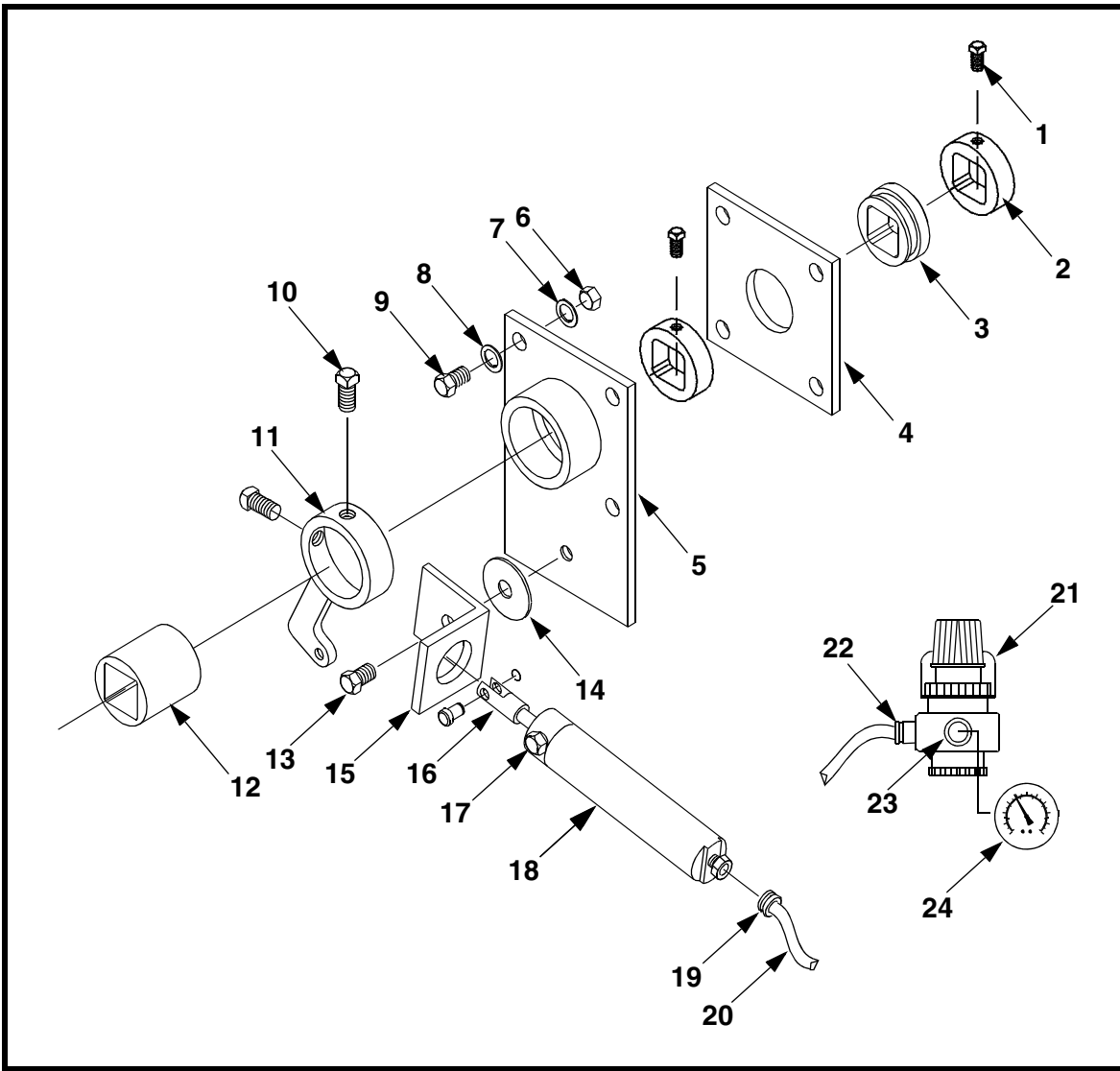
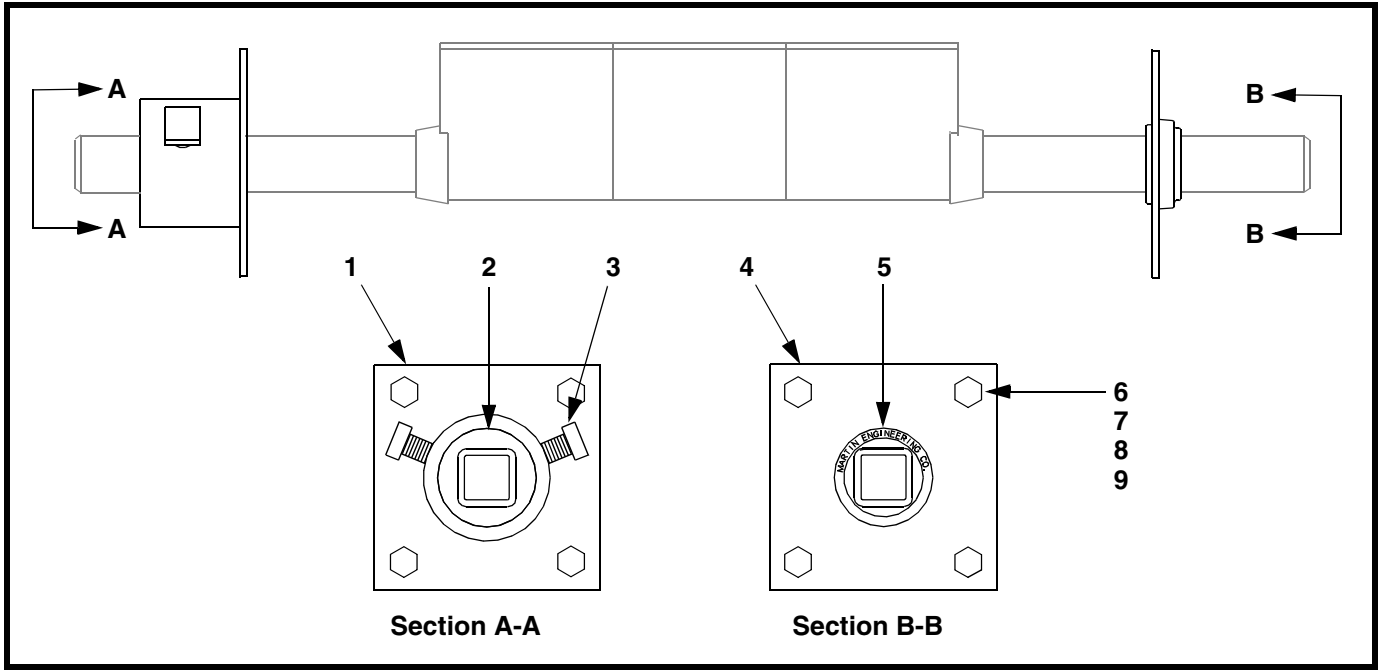

Figure 11. Martin[®] Air Tensioner Assembly, P/N 31348-SSP (Sheet 1 of 2)

Item	Description	Part No.	Qty
1	Screw SHS 1/4 -20NC x 1/2 SS	24298-04	2
2	Pipe Collar	33056	2
3	Pipe Bushing	32051-P	1
4	Far Side Mount Plate	31373-SS	1
5	Flange Plate Weldment	31355-SS	1
6	Nut Hex 3/8 -16NC	16054	8
7	Washer Compression 3/8	28565	8
8	Washer Flat 3/8	16055	8
9	Screw HHC 3/8 -16NC x 1-1/2	25281	8
10	Screw SHS 3/8 -16NC x 1/2	31393	2
11	Tensioning Arm Weldment	31357-SS	1
12	Sleeve	31351-P	1
13	Screw HHC 3/8 -16NC x 1/2	31359	1
14	Washer Nylon 7/16 ID x 1-1/2 OD	31392	1
15	Air Tensioner Support Plate	31358-SS	1
16	Piston Rod Clevis Assembly	31361	1
17	Vent Plut 1/8 NPT	31197	1
18	Air Cylinder	31360	1
19	Connector Male 1/8 NPT 1/4 OD	31321	1
20	Tubing Polyethelene 1/4	104233-01	5 ft
21	Pressure Regulator	31371	1
22	Fitting Male Push Lock 1/4 NPT	31196	1
23	Bushing Reducing 1/4 x 1/8	13259	1
24	Air Gauge	30437	1
Fig. 14	Air Pressure/ Warning Label	31391	1
Fig. 16	Conveyor Products Warning Label	23395	2

Figure 11. Martin® Air Tensioner Assembly, P/N 31348-SSP (Sheet 2 of 2)



Item	Description	Part No.	Qty
1	Hub Mount Weldment	Table VIII	1
2	Sleeve	Table VIII	1
3	Screw Set 3/8 -16NC x 1/2	31393	2
4	Far Side Mount Plate	Table VIII	1
5	Pipe Bushing	32051-P	1
6	Screw HHC 3/8 -16NC x 1-1/2	25281	8
7	Washer Flat 3/8	16055	8
8	Washer Compression 3/8	28565	8
9	Nut Hex 3/8	16054	8
Fig. 16	Label Conveyor Products Warning	23395	2

Figure 12. Martin® Hub Mount Tensioner Assembly, P/N 31368-XXX*

Table VIII. Martin® Hub Mount Tensioner Part Numbers**

Assembly Part No.	Item 1 Part No.	Item 2 Part No.	Item 4 Part No.
31368-SSP	31338-SS	31351-P	31373-SS
31368-SSN	31338-SS	31351-N	31373-SS
31368-MSP	31338	31351-P	31373
31368-MSN	31338	31351-N	31373

*First -XX indicates stainless steel or mild steel; last X indicates bushing material.

**MS = mild steel; SS = stainless steel; N = nylon; P = high-density polyethylene

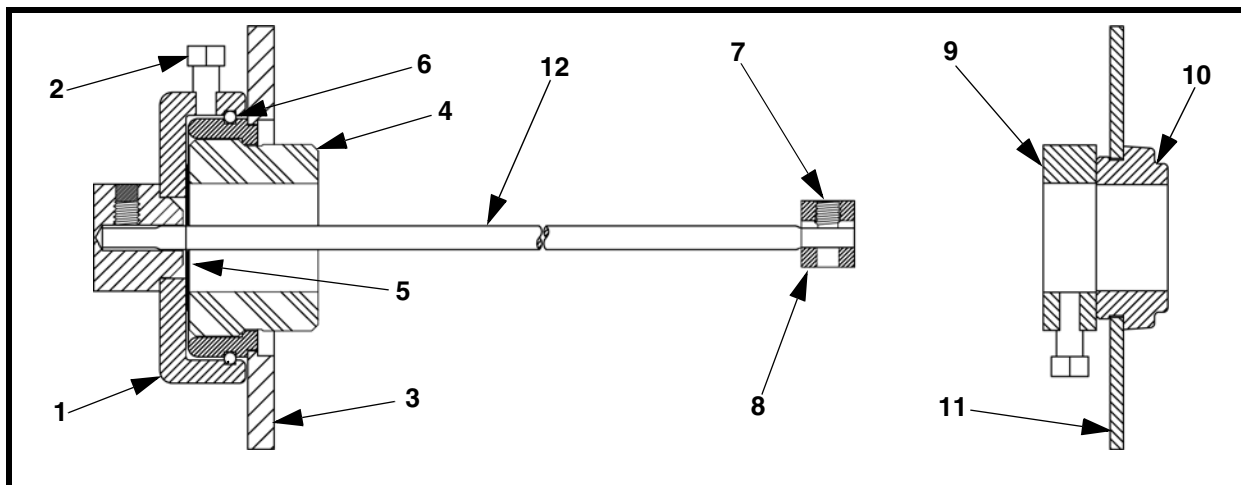

Item	Description	Part No.	Qty
1	Tensioner Spring Weldment	33050	1
2	Screw SHS 1/4 -20NC x 1/2	24298-04	2
3	Internal Mount Weldment	33045-SS	1
4	Tensioner Bearing	33042	1
5	Tensioner Spacer	33049	1
6	O-Ring 2-1/8 x 2-5/16	33047	1
7	Screw SHS 5/16 -18NC x 1/4	19933	2
8	Spring Holder	33038	1
9	Pipe Collar	33056	1
10	Pipe Bushing	32051-P	1
11	Far Side Mount Plate	31373-SS	1
12	Tensioner Spring	33048	1
NS	Screw HHC 3/8 -16NC x 1-1/2	25281	8
NS	Washer Flat 3/8	16055	8
NS	Washer Compression 3/8	28565	8
NS	Nut Hex 3/8 -16NC SS	16054	8
NS	Silicone GE RTV	100584	.01
Fig. 15	Torque/Warning Label	33298	1
Fig. 16	Label Conveyor Product Warning	23395	2

Figure 13. Martin® Internal Spring Tensioner Assembly, P/N 33036-P

NS=Not Shown

⚠ WARNING
⚠ ADVERTENCIA
<p>Lock out / tag out all energy sources to conveyor and loading systems before performing any work on conveyor or accessories. Failure to do so could result in severe injury or death.</p> <p>Do not apply over 125 psi (8.62 bar) to air tensioning components. Components can explode.</p>
<p>Cierre y/o rotule todas las fuentes de energía al sistemas transportador y de carga antes de realizar cualquier trabajo sobre el transportador o sobre los accesorios. Si no se procede así, puede resultar en heridas serias o muerte.</p> <p>No infle cojin neumatico a mas de 8.62 bar (125 psi). Los cojines neumaticos pueden explotar.</p>

Blade Coverage in. (mm)	No. of Blades	Martin® Air Tensioner Recommended Pressure psi (bar)				
		Pre-Cleaner**			Secondary**	
		P	U	N	P	N, A
4 (102)	1	4 (0.28)	2 (0.14)	7 (0.48)	5 (0.34)	8 (0.55)
8 (203)	2	7 (0.48)	4 (0.28)	14 (0.97)	10 (0.69)	16 (1.10)
12 (305)	3	11 (0.76)	5 (0.34)	21 (1.45)	15 (1.03)	24 (1.65)
16 (406)	4	14 (0.97)	7 (0.48)	28 (1.93)	20 (1.38)	32 (2.21)
24 (609)	6	21 (1.45)	11 (0.76)	42 (2.90)	29 (2.00)	48 (3.31)
28 (711)	7	25 (1.72)	12 (0.83)	49 (3.38)	34 (2.34)	56 (3.86)
36 (914)	9	32 (2.21)	16 (1.10)	63 (4.34)	44 (3.03)	*36 (2.48)
40 (1016)	10	35 (2.34)	18 (1.24)	70 (4.83)	49 (3.38)	*40 (2.76)
48 (1219)	12	42 (2.90)	21 (1.45)	*42 (2.90)	59 (4.06)	*48 (3.31)
56 (1422)	14	49 (3.38)	25 (1.72)	*49 (3.38)	*31 (2.14)	*56 (3.86)
64 (1626)	16	56 (3.86)	28 (1.93)	*56 (3.86)	*34 (2.34)	*60 (4.14)

*Pressure per side. Dual tensioners required.
 **P=low- or high-density polyethylene, U=linear low-density polyethylene, N=nylon,
 A= aluminum Label P/N 31391

Figure 14. Martin® Pressure/Warning Tag, P/N 31391

⚠ WARNING
⚠ ADVERTENCIA
<p>Lock out / tag out all energy sources to conveyor and loading systems before performing any work on conveyor or accessories. Failure to do so could result in serious injury or death.</p>
<p>Cierre y/o rotule todas las fuentes de energía al sistemas transportador y de carga antes de realizar cualquier trabajo sobre el transportador o los accesorios. Si no se procede asi, puede resultar en heridas serias o muerte.</p>

Blade Coverage in. (mm)	No. of Blades	Martin® Hub Mount and Internal Spring Tensioner Recommended Torque—in.-lb (Nm)				
		Pre-Cleaner**			Secondary**	
		P	U	N	P	N, A
4 (102)	1	2 (.23)	1 (.13)	3 (.34)	3 (.34)	5 (.57)
8 (203)	2	3 (.34)	1.5 (.17)	6 (.68)	4 (.45)	10 (1.1)
12 (305)	3	4 (.45)	2 (.23)	8 (.90)	6 (.68)	15 (1.7)
16 (406)	4	6 (.68)	3 (.34)	11 (1.2)	11 (1.2)	20 (2.3)
24 (609)	6	8 (.90)	4 (.45)	17 (1.9)	17 (1.9)	15 (1.7)*
28 (711)	7	10 (1.1)	5 (.57)	19 (2.1)	20 (2.3)	18 (2.0)*
36 (914)	9	12 (1.4)	6 (.68)	13 (1.5)*	13 (1.5)*	23 (2.6)*
40 (1016)	10	14 (1.6)	7 (.79)	14 (1.6)*	14 (1.6)*	***
48 (1219)	12	17 (1.9)	8 (.90)	17 (1.9)*	17 (1.9)*	***
56 (1422)	14	19 (2.1)	10 (1.1)	20 (2.3)*	20 (2.3)*	***
64 (1626)	16	22 (2.5)	11 (1.2)	22 (2.5)*	23 (2.6)*	***

*Torque per side. Dual tensioners required.
 **P=low- or high-density polyethylene, U=linear low-density polyethylene, N=nylon, A=aluminum
 ***Air Tensioners required
 Label P/N 33298

Figure 15. Martin® Torque/Warning Tag, P/N 33298

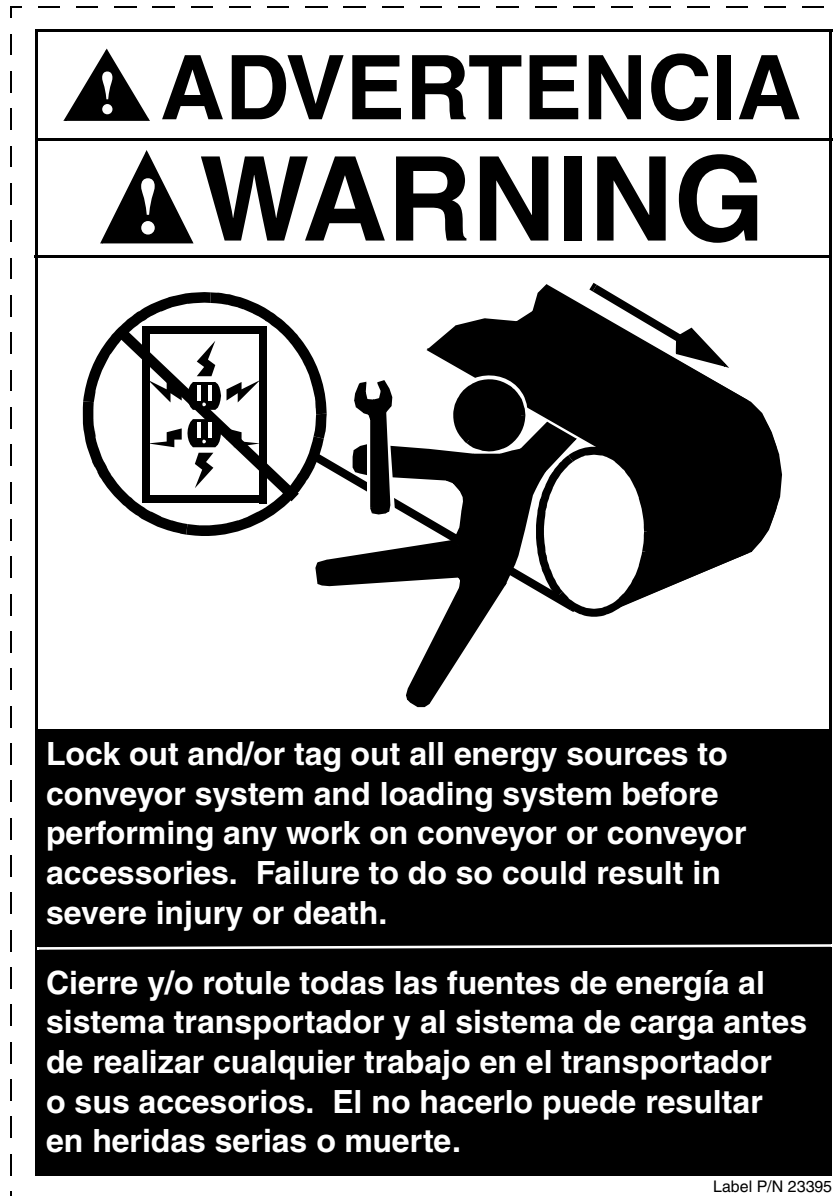
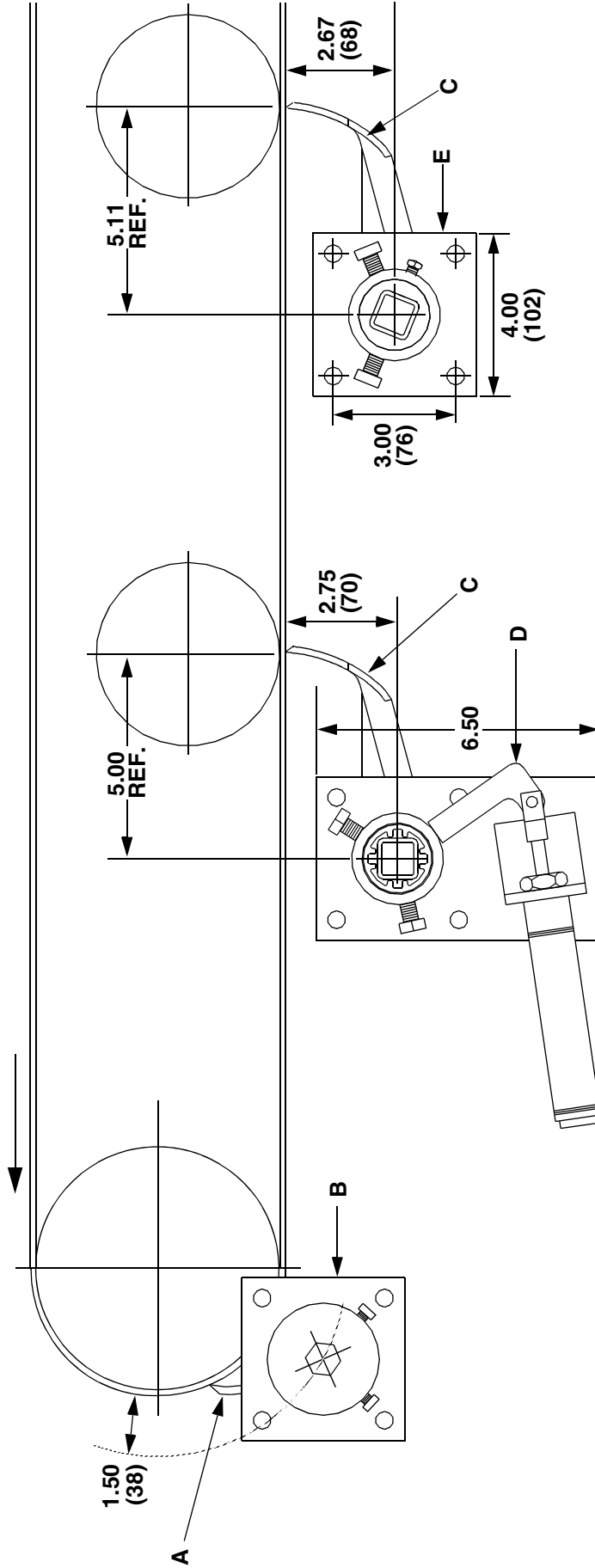

Figure 16. Conveyor Product Warning Label, P/N 23395

Appendix A

Typical Martin® Food Grade Installations



- A. Martin® Food Grade Pre-Cleaner, P/N 33035-XXX
- B. Martin® Internal Spring Tensioner, P/N 33036
- C. Martin® Food Grade Secondary Cleaner, P/N 31369-XXX
- D. Martin® Air Tensioner, P/N 31348-XXX
- E. Martin® Hub Mount Tensioner, P/N 31368-XXX

Appendix B

Typical Electrical and Pneumatic Schematics for Martin® Food Grade Cleaner Reversing Belt Application

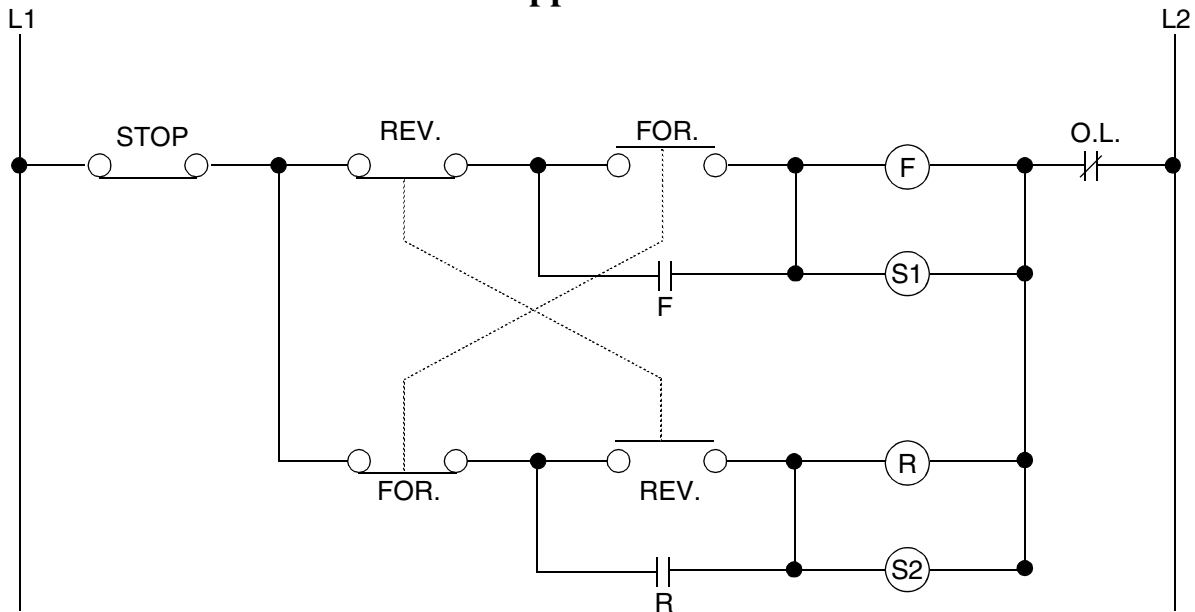

Electrical

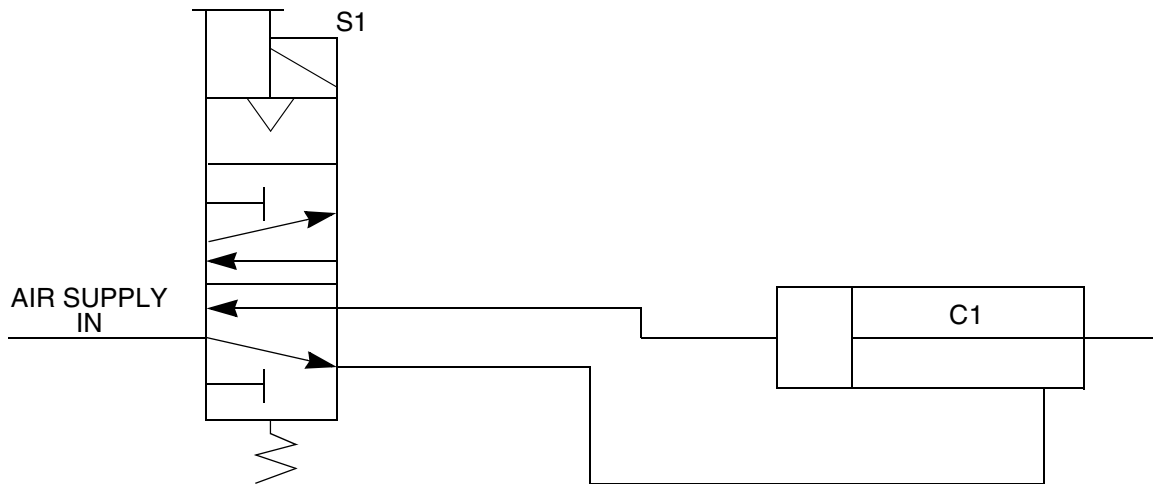

Pneumatic

- Typical piping schematic for S1 and S2 to respective cylinders. S1 and S2 are 2-way, 5-position solenoid valves.
- Upon conveyor shutdown, both cleaners will back away from belt for washdown and maintenance.

Any product, process, or technology described here may be the subject of intellectual property rights reserved by Martin Engineering Company. Trademarks or service marks designated with the ® symbol are registered with the U.S. Patent and Trademark Office and may be proprietary in one or more countries or regions. Other trademarks and service marks belonging to Martin Engineering Company in the United States and/or other countries or regions may be designated with the “TM” and “SM” symbols. Brands, trademarks, and names of other parties, who may or may not be affiliated with, connected to, or endorsed by Martin Engineering Company, are identified wherever possible. Additional information regarding Martin Engineering Company’s intellectual property can be obtained at www.martin-eng.com/trademarks.

Problem Solved™ GUARANTEED!

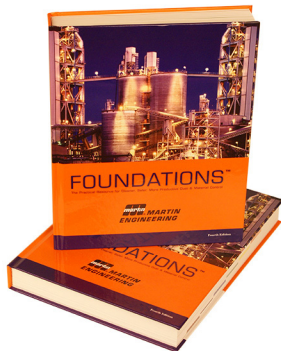

For nearly 20 years, Martin Engineering's Foundations™ Books have taught industry personnel to operate and maintain clean and safe belt conveyors. The Foundations™ Book, fourth edition, focuses on improving belt conveyors by controlling fugitive material. "The Practical Resource for Total Dust and Material Control," is a 576-page hard cover volume that provides information of value to industries where the efficient handling of bulk materials is a key to productivity and profitability.

Expanding upon the book, our Foundations™ Training Program addresses the design and development of more productive belt conveyors, and is offered in three customizable seminars. Attendees gain a better understanding of conveyor safety and performance, helping to justify upgrade investments and increase profitability.



Martin Engineering Australia Pty Ltd.
102 Christensen Road South
Stapylton QLD 4207 - Australia
+61 1300 627 364
salesau@martin-eng.com | www.martin-eng.com.au

