

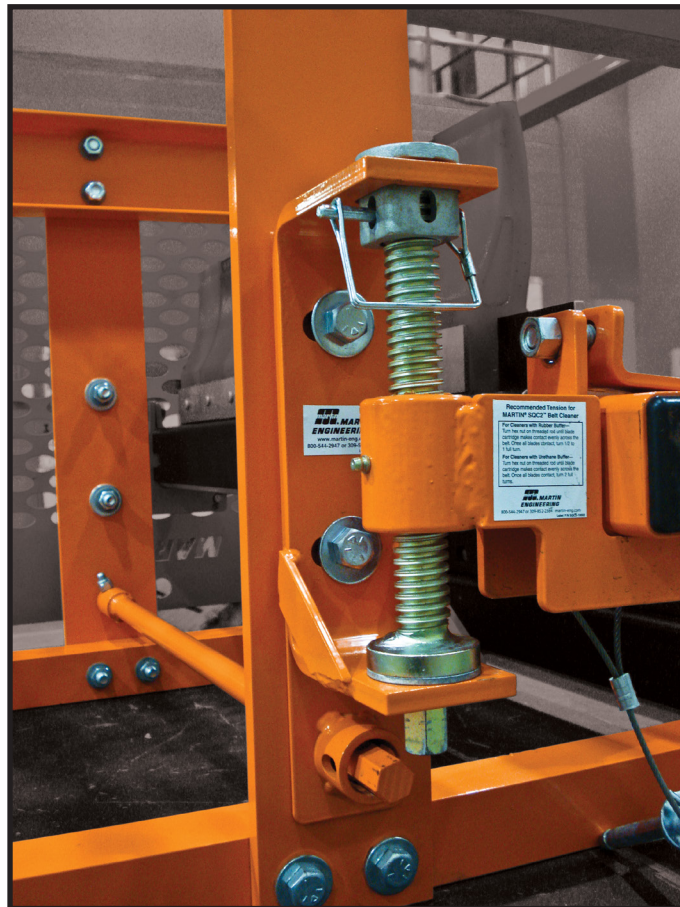

Martin® Farside Tension Adjuster



**Operator's Manual
M3899**

Important

MARTIN ENGINEERING HEREBY DISCLAIMS ANY LIABILITY FOR: DAMAGE DUE TO CONTAMINATION OF THE MATERIAL; USER'S FAILURE TO INSPECT, MAINTAIN AND TAKE REASONABLE CARE OF THE EQUIPMENT; INJURIES OR DAMAGE RESULTING FROM USE OR APPLICATION OF THIS PRODUCT CONTRARY TO INSTRUCTIONS AND SPECIFICATIONS CONTAINED HEREIN. MARTIN ENGINEERING'S LIABILITY SHALL BE LIMITED TO REPAIR OR REPLACEMENT OF EQUIPMENT SHOWN TO BE DEFECTIVE.

Observe all safety rules given herein along with owner and Government standards and regulations. Know and understand lockout/tagout procedures as defined by American National Standards Institute (ANSI) z244.1-1982, *American National Standard for Personnel Protection - Lockout/Tagout of Energy Sources - Minimum Safety Requirements* and Occupational Safety and Health Administration (OSHA) Federal Register, Part IV, 29 CFR Part 1910, *Control of Hazardous Energy Source (Lockout/Tagout); Final Rule*.

The following symbols may be used in this manual:



Danger: Immediate hazards that will result in severe personal injury or death.



Warning: Hazards or unsafe practices that could result in personal injury.



Caution: Hazards or unsafe practices that could result in product or property damages.



Important: Instructions that must be followed to ensure proper installation/operation of equipment.



Note: General statements to assist the reader.

Table of Contents

Section	Page
List of Figures and Tables	ii
Introduction	1
General	1
Installations without chutework	1
Belt cleaner inspection access	1
References	1
Safety	2
Before Installing Belt Cleaner and Tensioner	3
Installing Belt Cleaner and Tensioner	4
Tensioner Installation	4
Belt Cleaner Installation	6
Tensioning Belt Cleaner	8
After Installing Belt Cleaner and Tensioner	9
Weekly Maintenance	10
Troubleshooting	11
Part Numbers	12
Appendix	A-1

List of Figures

Figure	Title	Page
1	Martin [®] Farside Tension Adjuster Assembly, P/N 38664-DXX	13
2	Conveyor Products Warning Label, P/N 23395	16
3	Martin [®] SQC2S [™] Tensioning Label, P/N SQC2-10002.	16

Introduction

General

To introduce product back into the product flow, a Pre-Cleaner is installed on the face of the head pulley. On a dual cleaner system, the Secondary Cleaner is installed immediately following the Pre-Cleaner to remove stubborn material left on the conveyor belt. If a Pre-Cleaner cannot be used because of space limitations, the Secondary Cleaner is installed alone. If the material-handling process or product could be affected by contamination from the use of these belt cleaners, the user is responsible for taking the necessary steps to prevent contamination. Consult Martin Engineering or a representative for alternate belt cleaners or belt cleaner locations to use where contamination may be an issue.

Installations without chutework

These procedures were written for equipment that is being installed on enclosed pulley chutework. If the pulley is not enclosed, the equipment should be installed using the best available field resources and methods to ensure that the critical dimensions are followed for proper installation.

Belt cleaner inspection access

If the belt cleaner is installed on enclosed pulley chutework, a Martin® Inspection Door should be installed. Martin® Inspection Doors are available from Martin Engineering or a representative.

References

The following documents are referenced in this manual:

- American National Standards Institute (ANSI) z244.1-1982, *American National Standard for Personnel Protection - Lockout/Tagout of Energy Sources - Minimum Safety Requirements*, American National Standards Institute Inc., 1430 Broadway, New York, NY 10018.
- Federal Register, Volume 54, Number 169, Part IV, 29 CFR Part 1910, *Control of Hazardous Energy Source (Lockout/Tagout); Final Rule*, Department of Labor, Occupational Safety and Health Administration (OSHA), 32nd Floor, Room 3244, 230 South Dearborn Street, Chicago, IL 60604.
- Martin® SAF2™ Heavy Duty & Martin® SQC2S™ Heavy Duty Max Cleaner Operator's Manual, P/N M3820
- Martin® H2O Cleaner Operator's Manual, P/N M3825

Safety

All safety rules defined in the above documents and all owner/employer safety rules must be strictly followed when working on the belt cleaner.

⚠ DANGER

Do not touch or go near the conveyor belt or conveyor accessories when the belt is running. Your body or clothing can get caught and you can be pulled into the conveyor, resulting in severe injury or death.

⚠ DANGER

Before installing, servicing, or adjusting the belt cleaner, turn off and lock out/tag out all energy sources to the conveyor and conveyor accessories according to ANSI standards. Failure to do so could result in serious injury or death.

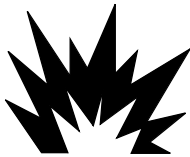
⚠ DANGER

If this equipment will be installed in an enclosed area, test the gas level or dust content before using a cutting torch or welding. Using a torch or welding in an area with gas or dust may cause an explosion resulting in serious injury or death.

⚠ WARNING

Before using a cutting torch or welding the chute wall, cover the conveyor belt with a fire retardant cover. Failure to do so can allow the belt to catch fire.

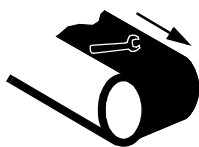
⚠ WARNING

Remove all tools from the installation area and conveyor belt before turning on the conveyor. Failure to do so can cause serious injury to personnel or damage to the belt and conveyor.

⚠ WARNING

Mainframe with blade can be heavy and may require two people to lift. Attempting to lift the belt cleaner without assistance could result in injury.

Before Installing Belt Cleaner and Tensioner

IMPORTANT

The delivery service is responsible for damage occurring in transit. Martin Engineering CANNOT enter claims for damages. Contact your transportation agent for more information.

1. Inspect shipping container for damage. Report damage to delivery service immediately and fill out delivery service's claim form. Keep any damaged goods subject to examination.
2. Remove tensioner assembly from shipping container.
3. If anything is missing contact Martin Engineering or a representative.



WARNING

Before installing equipment, turn off and lock out/ tag out all energy sources to the conveyor and conveyor accessories according to ANSI standards. Failure to do so could result in serious injury or death.

4. Turn off and lock out/tag out energy source according to ANSI standards (see "References").

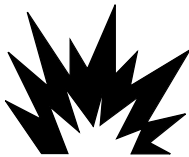

DANGER

If this equipment will be installed in an enclosed area, test the gas level or dust content before using a cutting torch or welding. Using a torch or welding in an area with gas or dust may cause an explosion resulting in serious injury or death.

5. If using a cutting torch or welding, test atmosphere for gas level or dust content. Cover conveyor belt with fire retardant cover.

IMPORTANT

Center the belt cleaner blades to clean an area narrower than the conveyor belt width. This allows for side-to-side movement of the belt and prevents damage to the belt edge.

NOTE

The chute wall that the tensioner will be located on is referred to as the "operator side." The other side of the chute is referred to as the "far side." (If installing dual tensioners, side that is most accessible is "operator side.")

6. Determine which side of chute is easiest to access. Locate the tensioner on the most accessible chute wall.

Installing Belt Cleaner and Tensioner

Tensioner Installation

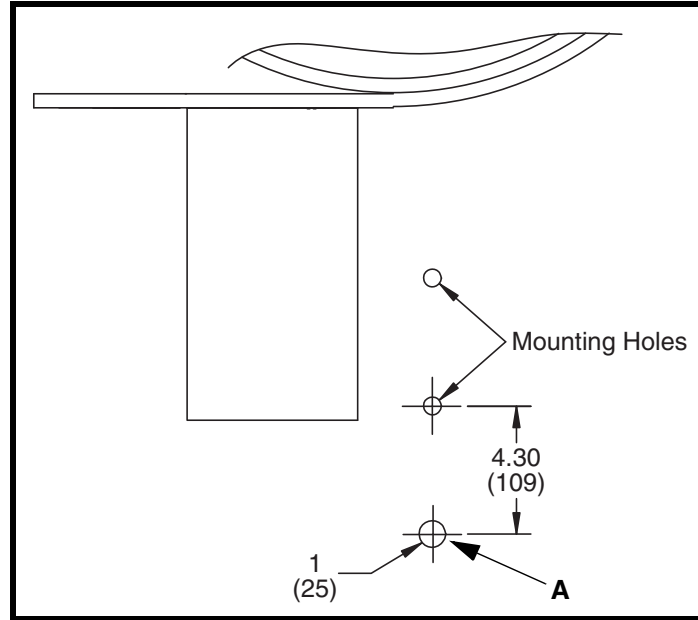

1. Locate, mark, and cut cleaner access slots and mount holes according to appropriate belt cleaner operator's manual (See "References").

NOTE

Telescoping shaft hole must be aligned with tensioner. If tensioner is rotated in mounting holes, telescoping shaft hole must also be rotated to remain aligned with tensioner. Adapter plate can be used as a template.

2. Locate, mark, and cut hole (A) for the telescoping shaft as shown.

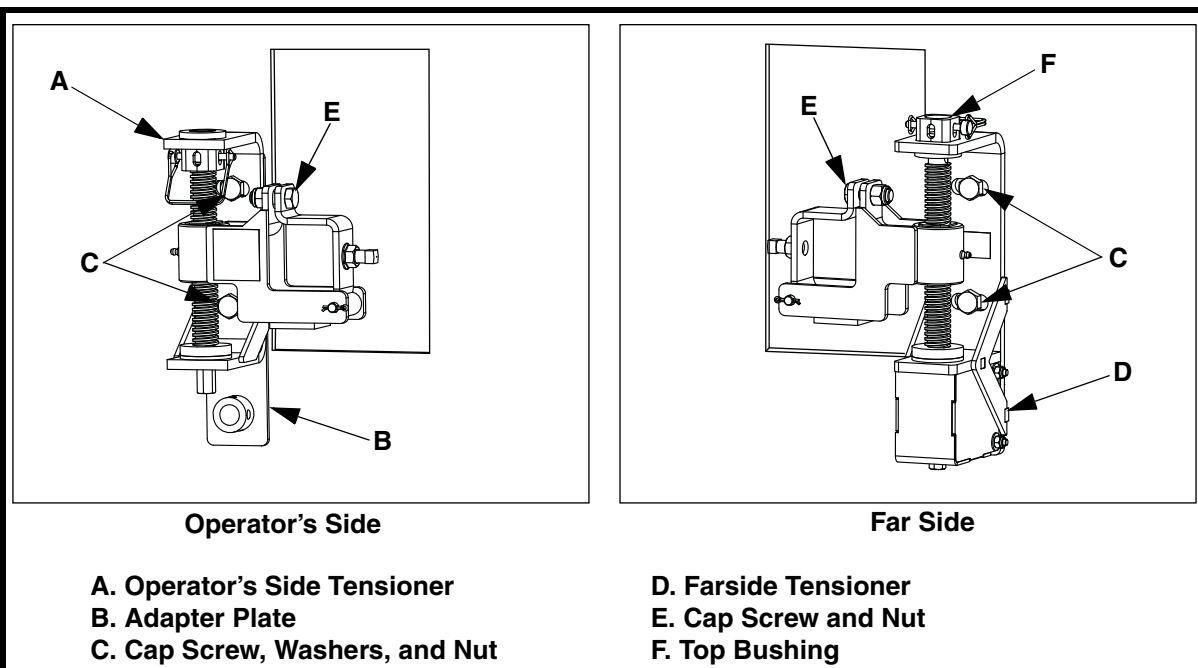

3. Mount operator's side tensioner (A) and adapter plate (B) to the operator's side chute wall using cap screws, washers, and nuts (C).
4. Mount farside tensioner (D) to the far side chute wall using cap screws, washers, and nuts (C).

NOTE

Top bushing (F) must be installed upside down on farside tensioner (as shown) to allow tensioner to be adjusted from operator's side.

5. For belt cleaners using Martin[®] SAF2™ style blades, rotate tensioners up to 10° as shown in operator's manual, P/N M3820.
6. Remove cap screws and nuts (E) from tensioners.

Installation

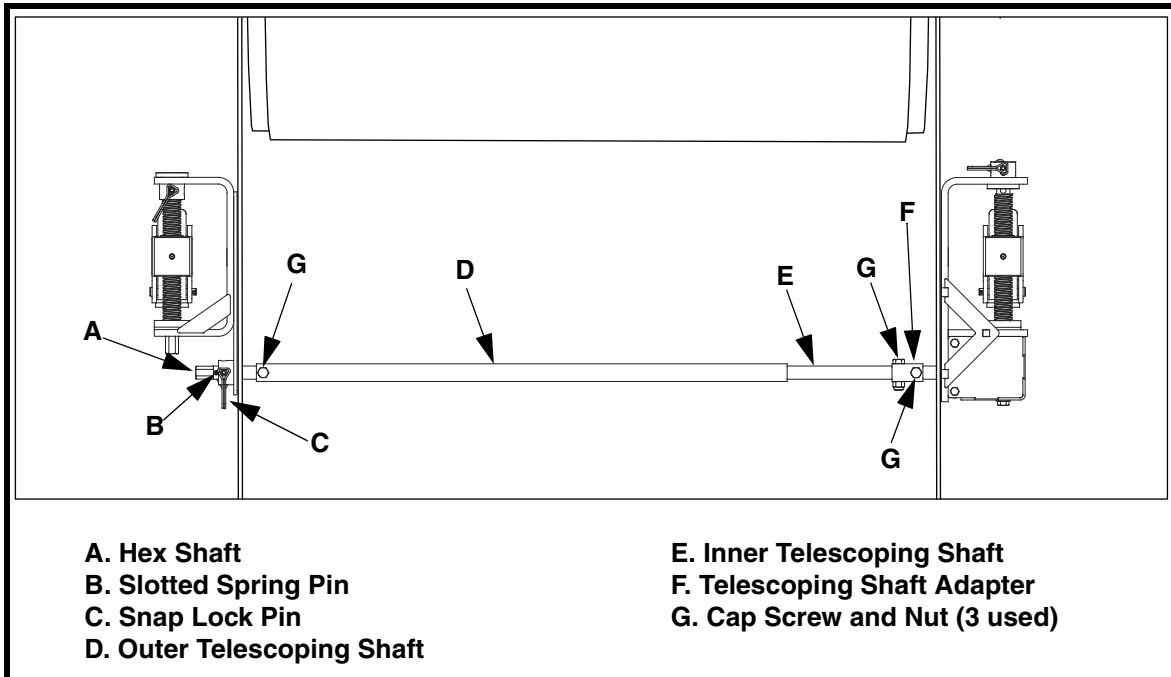

7. Install hex shaft (A) into adapter plate.
8. Slide inner telescoping shaft (E) into outer telescoping shaft (D).
9. Attach telescoping shaft adapter (F) to farside tensioner shaft using cap screw and nut (G).
10. Attach telescoping shafts to shaft adapter (F) and hex shaft (A) using cap screws and nuts (G).

Belt Cleaner Installation

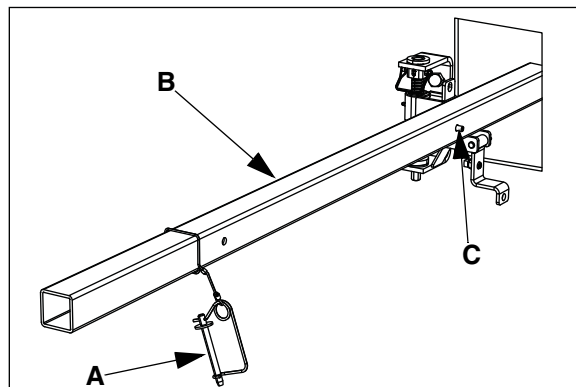

1. Remove blade cartridge according to appropriate belt cleaner operator's manual.
2. Slide mainframe (B) through chute wall cutouts and into position on tensioners. Make sure roll pin (C) is located on farside of mainframe and lanyard for pin (A) is on operator side of mainframe.

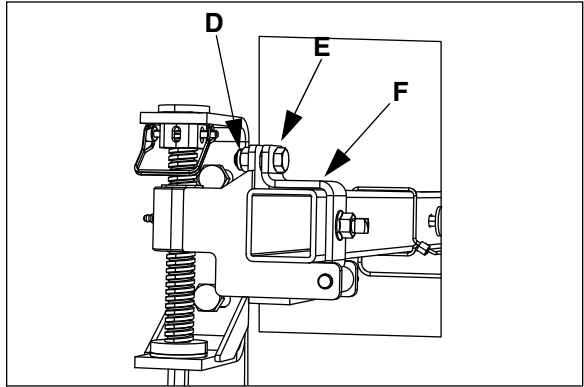

- 3. Rotate hinge clamp (F) into position and install cap screw (D) and nut (E). Hand tighten nut.
- 4. Repeat step 3 on farside tensioner.

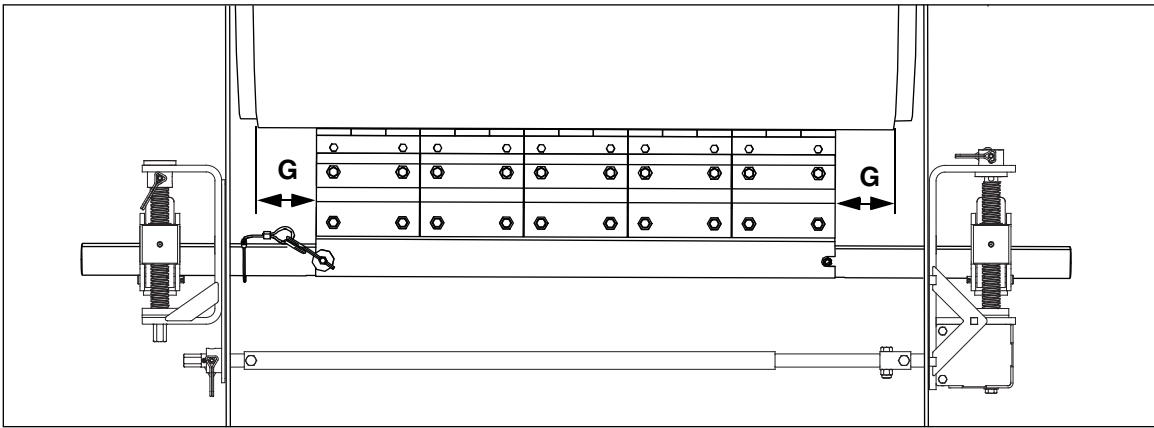

- 5. Install blade cartridge according to appropriate belt cleaner operator's manual.
- 6. Center blade on belt.

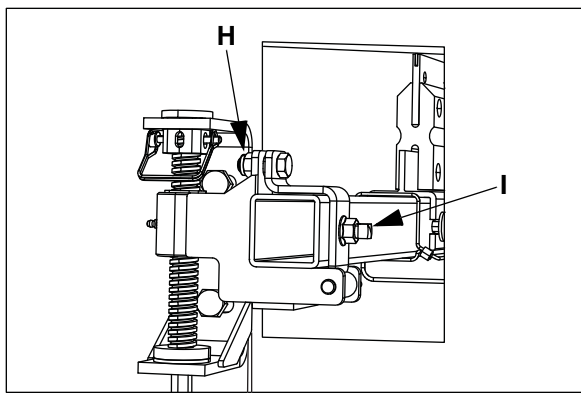

- 7. Tighten nut (H) and set screw (I).

**Tensioning Belt
Cleaner**

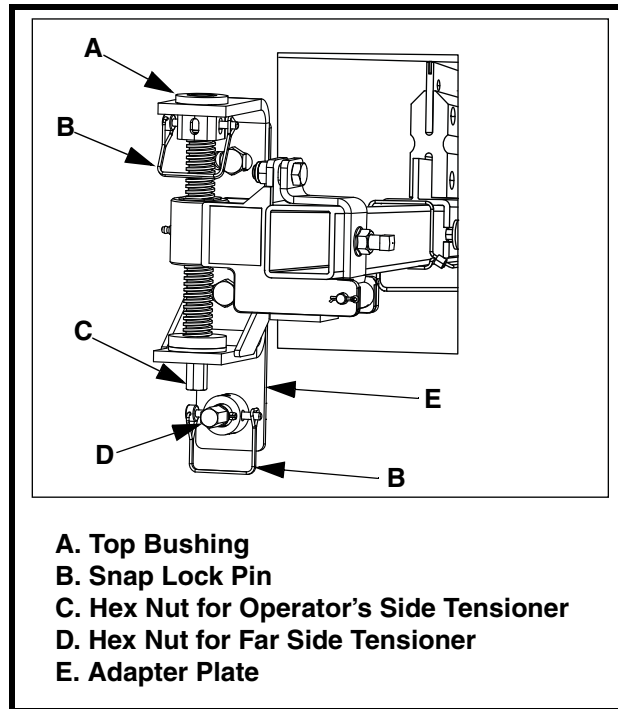

IMPORTANT

Hex nuts (C and D) must be turned evenly to prevent the tensioners from binding.

1. Remove snap lock pins (B).
2. Tension belt cleaner according to blade type used.
 - a. For cleaners with rubber buffer:
 - (1) Turn hex nuts (C and D) until blade cartridge makes contact evenly across the belt.
 - (2) Once all blades contact, turn 1/2 to 1 full turn.
 - b. For cleaners with urethane buffers:
 - (1) Turn hex nuts (C and D) until blade cartridge makes contact evenly across the belt.
 - (2) Once all blades contact, turn 2 full turns.
3. Align holes on threaded rod with holes in top bushing (A) and insert snap lock pin (B).
4. Align holes on hex shaft with holes in adapter plate (E) and insert snap lock pin (B).

After Installing Belt Cleaner and Tensioner



1. Thoroughly wipe chute wall clean above tensioner.
2. Place Conveyor Products Warning Label (P/N 23395) on outside chute wall visible to belt cleaner operator.

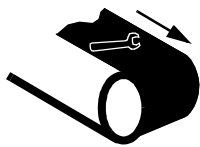

WARNING

Failure to remove tools from installation area and conveyor belt before turning on energy source can cause serious injury to personnel and damage to belt.



DANGER

Do not touch or go near conveyor belt or conveyor accessories when conveyor belt is running. Body or clothing can get caught and pull body into conveyor belt, causing severe injury or death.

3. Turn on conveyor belt for 1 hour, then turn off.



DANGER

Before installing, servicing, or adjusting the belt cleaner/tensioner, turn off and lock out/tag out all energy sources to the conveyor and conveyor accessories according to ANSI standards. Failure to do so could result in serious injury or death.

4. Make sure all fasteners are tight. Tighten if necessary.
5. Make sure cleaner is not changing belt line. If it is, install belt support ahead of blade-to-belt contact point (Secondary Cleaner).
6. Inspect belt cleaner for the following:
 - Wear. (A small amount of “break-in” wear may be found. This will stop once blades wear to conveyor belt contour.)
 - Material buildup. (No material between blades and return side of conveyor belt should be found.)
7. If wear, material buildup, or some other problem exists, see “Troubleshooting.”

Weekly Maintenance

IMPORTANT

Read entire section before beginning work.

NOTE

Maintenance inspection should be performed no less than weekly. Some applications may require more frequent maintenance inspections.



⚠ DANGER

Before installing, servicing, or adjusting the belt cleaner/tensioner, turn off and lock out/tag out all energy sources to the conveyor and conveyor accessories according to ANSI standards. Failure to do so could result in serious injury or death.

1. Remove any material from belt cleaner.
2. Make sure all fasteners are tight. Tighten if necessary.
3. Check tension on cleaner. Re-tension if necessary.
4. Wipe all labels clean. If labels are not readable, contact Martin Engineering or a representative for replacements.
5. Check blades for excessive wear. Replace if necessary.
6. Remove equipment from service if there is any indication it is not functioning properly. Call Martin Engineering or a representative for assistance. Do NOT return equipment to operation until the cause of the problem has been identified and corrected.

⚠ WARNING

Failure to remove tools from installation area and conveyor belt before turning on energy source can cause serious injury to personnel and damage to belt.

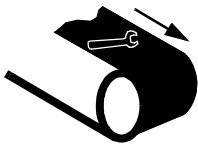

7. Remove all tools from maintenance area.

⚠ DANGER

Do not touch or go near conveyor belt or conveyor accessories when conveyor belt is running. Body or clothing can get caught and pull body into conveyor belt, causing severe injury or death.



8. Start conveyor belt.

Troubleshooting

Symptom	Corrective Action
Insufficient cleaning and carryback.	<ul style="list-style-type: none"> • Tension of cleaner on belt is set too low or too high. Increase or decrease tensioner setting. • Blades are worn. Check blades and replace if necessary.
Noise or vibration.	Tension is not sufficient or is set too high. Correct tension as necessary. If this does not correct problem, blade urethane may not match application. Contact Martin Engineering or representative.
High blade wear rate.	Tension of cleaner on belt is set too high. Reduce tensioner setting.
Unusual wear or damage to blades.	Check belt splice(s) and repair as necessary.
Bent or broken mainframe or support frame due to blade slipping through.	If blades are worn to or past the wear line, replace blades. If blades are not worn, check mainframe location.
Corrosion or chemical degradation.	Blade urethane may not match application. Contact Martin Engineering or representative.

NOTE

Conveyor equipment such as conveyor belt cleaners are subject to a wide variety of bulk materials characteristics and often have to perform under extreme operating or environmental conditions. It is not possible to predict all circumstances that may require troubleshooting. Contact Martin Engineering or a representative if you are experiencing problems other than those listed in the “Troubleshooting” chart above. Do not return the equipment to operation until the problem has been identified and corrected.

Installation checklist

If after taking the corrective actions suggested under “Troubleshooting” you are still experiencing problems, check for the following:

Installation Checklist
✓ Pre-Cleaner mainframe is proper distance from belt surface on both ends of mainframe.
✓ Pre-Cleaner blade tip is at or below horizontal center line of pulley and does not lie in path of material flow.
✓ Secondary Cleaner blade tip is 2 in. (51 mm) past vertical center line of pulley.
✓ Secondary Cleaner is not changing belt line.
✓ Blades are centered on belt.

Part Numbers

***Martin® Farside
Tension Adjuster***

Martin® Farside Tension Adjuster: P/N 38664-DXX.
See Figure 1.

***Martin® Belt
Cleaners***

Martin® SQC2S™ Heavy Duty Max Cleaner Assembly:
P/N SQC2S-XXXXXXXXXX.

Martin® SAF2™ Heavy Duty Cleaner Assembly:
P/N SAF2S-XXXXXXXX3XX.

Mini Martin® SQC2S™ Heavy Duty Max Cleaner Assembly:
P/N SQC2MS-XXXXXXXXXX.

Martin® H2O Cleaner Assembly: P/N H2O4000S-XXXX.

Miscellaneous

Martin® Heavy-Duty Hanger Mount Assembly: P/N 34233-HD. Used to mount Martin® Farside Tension Adjuster onto stringer instead of onto chute wall.

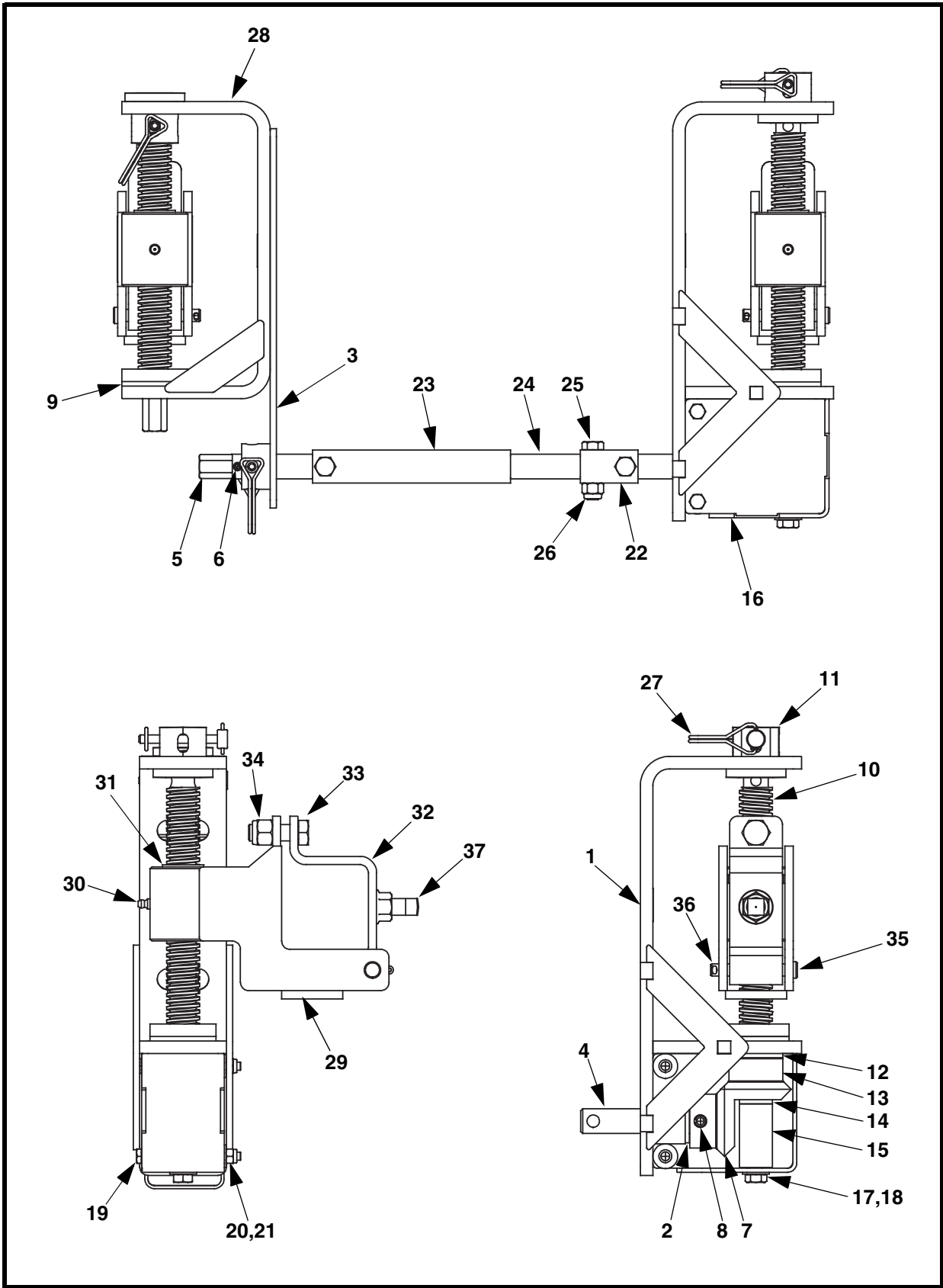

Figure 1. Martin® Farside Tension Adjuster Assembly, P/N 38664-DXX

Part Numbers

Item	Description	Part Number	Qty
1	Mount Weldment	38854	1
2	Bearing Flanged .75 x 1.00 x 1.31	38862	1
3	Adapter Plate Weldment	38855	1
4	Gear Shaft	38857	1
5	Hex Shaft	38859-H	1
6	Pin Slotted Spring 1/4 x 1-1/8 ZP	38578	1
7	Bevel Gear	38856-D	1
8	Pin Slotted Spring 3/8 x 1-1/2	36550	1
9	Bottom Bushing	35674	2
10	Tensioning Rod	35682	2
11	Top Bushing	35683-C	2
12	Washer Thrust 1.00 x 1.63 x .13	38863	1
13	Bevel Gear with Hex	38856-H	1
14	Bearing Flanged .505 x .752 x 1.00	38864	1
15	Gear Support Post	38858-P	1
16	Gear Box Weldment	38858-W	1
17	Washer Compression 3/8	11747	1
18	Screw HHC 3/8-16NC x 3/4 ZP	12597	1
19	Screw HHC 1/4-20NC x 3 ZP	38951	2
20	Washer Compression 1/4	11521	2
21	Nut Hex Elastic Lock 1/4-20NC ZP	30227	2
22	Telescoping Tube Adapter	38859-A	1
23	Telescoping Outer Shaft	Table I	1
24	Telescoping Inner Shaft	Table I	1
25	Screw HHC 3/8-16NC x 1-1/2 ZP	32719	3
26	Nut Hex Elastic 3/8-16NC ZP	14201	3
27	Snap Lock Pin 1/4 x 2-1/4 ZP	35685	3
28	Mount Bracket Weldment	35672	1
29	Tension Arm Assembly	38663	2
30	Fitting Grease	38584	2
31	Pivot Block Insert	35684	2

Item	Description	Part Number	Qty
32	Hinge Clamp Weldment	38661	2
33	Screw HHC 1/2-13NC x 1-1/2 ZP	11763	2
34	Nut Hex Elastic 1/2-13NC ZP	18577	2
35	Pin Clevis 3/8 x 2-1/2 ZP	35687	2
36	Pin Cotter 1/8 x 3/4 SS	31297	2
37	Screw SHS 1/2-13NC x 1 SS	22763-03	2
38 (NS)	Label Martin Product	32238	2
39 (NS)	Label Tensioning	SQC2-10002	2
40 (NS)	Mounting Hardware Kit	35283	1
41 (NS)	Label Conveyor Products Warning	23395	2
42 (NS)	Manual Operators	M3899	1

Figure 1. Martin® Farside Tension Adjuster Assembly, P/N 38664-DXX

Table I. Martin® Farside Tension Adjuster Assembly Part Numbers

Assembly Part No.	P/N Item 23	P/N Item 24
38664-D01	38859-29	38859-29I
38664-D02	38859-47	38859-47I
38664-D03	38859-65	38859-65I
38664-D04	38859-77	38859-77I

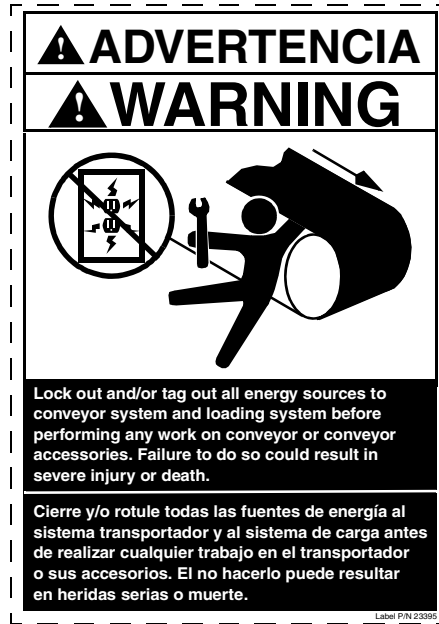

Figure 2. Conveyor Products Warning Label, P/N 23395

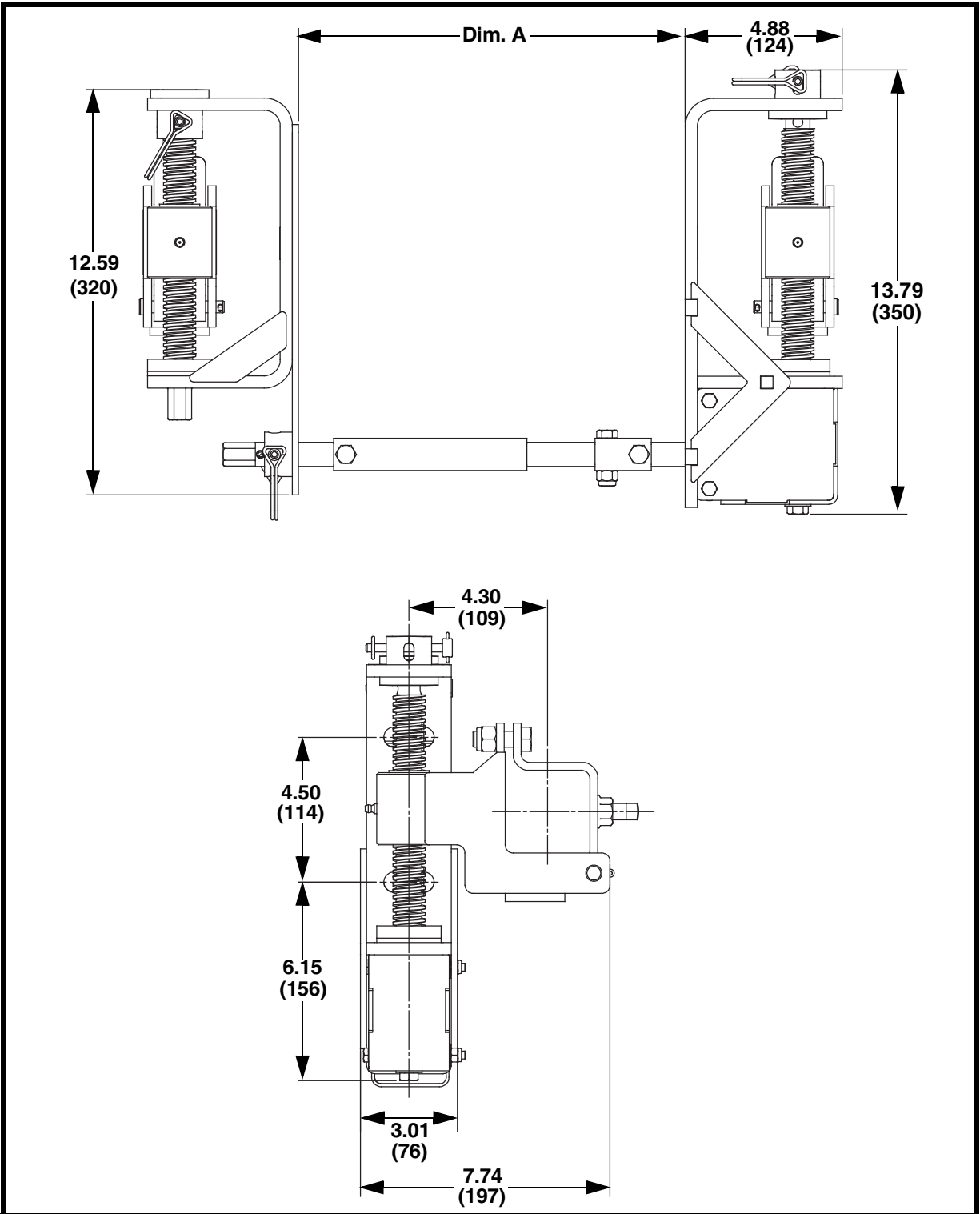

Figure 3. Martin® SQC2S™ Tensioning Label, P/N SQC2-10002

Appendix

Martin® Farside Tension Adjuster Assembly Dimensions

Appendix



Assembly Part No.	Dim. A Max Width
38664-D01	56.00
38664-D02	80.00

Assembly Part No.	Dim. A Max Width
38664-D03	116.00
38664-D04	140.00

Martin® SQC2S™ Square Mainframe Tensioner Arm Height Adjustment

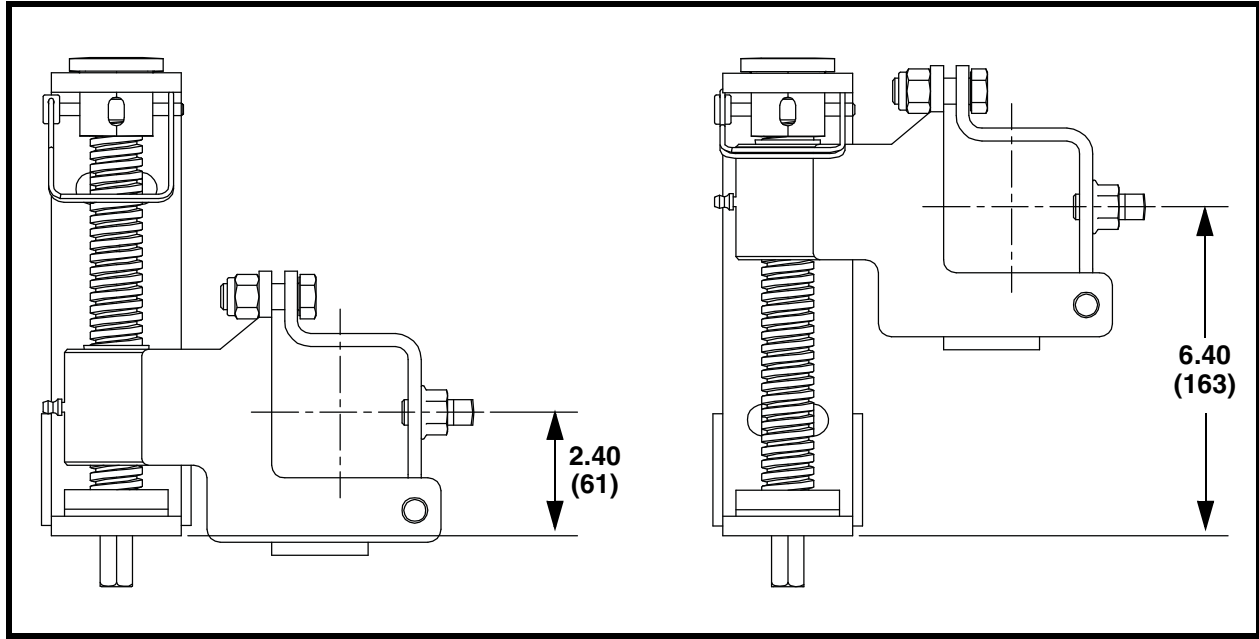

Any product, process, or technology described here may be the subject of intellectual property rights reserved by Martin Engineering Company. Trademarks or service marks designated with the ® symbol are registered with the U.S. Patent and Trademark Office and may be proprietary in one or more countries or regions. Other trademarks and service marks belonging to Martin Engineering Company in the United States and/or other countries or regions may be designated with the “TM” and “SM” symbols. Brands, trademarks, and names of other parties, who may or may not be affiliated with, connected to, or endorsed by Martin Engineering Company, are identified wherever possible. Additional information regarding Martin Engineering Company’s intellectual property can be obtained at www.martin-eng.com/trademarks.

Problem Solved™ GUARANTEED!

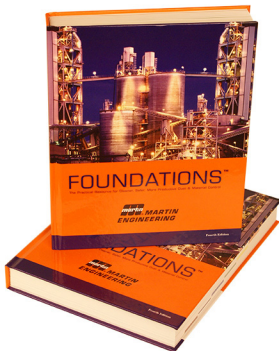

For nearly 20 years, Martin Engineering's Foundations™ Books have taught industry personnel to operate and maintain clean and safe belt conveyors. The Foundations™ Book, fourth edition, focuses on improving belt conveyors by controlling fugitive material. "The Practical Resource for Total Dust and Material Control," is a 576-page hard cover volume that provides information of value to industries where the efficient handling of bulk materials is a key to productivity and profitability.

Expanding upon the book, our Foundations™ Training Program addresses the design and development of more productive belt conveyors, and is offered in three customizable seminars. Attendees gain a better understanding of conveyor safety and performance, helping to justify upgrade investments and increase profitability.



Martin Engineering Australia Pty Ltd.
20 Ern Harley Dr - Burleigh Heads, QLD, 4220 - Australia
1300 627 364
www.martin-eng.com.au

