

martin®

Martin® ***DT2H***
Reversing Cleaner XHD

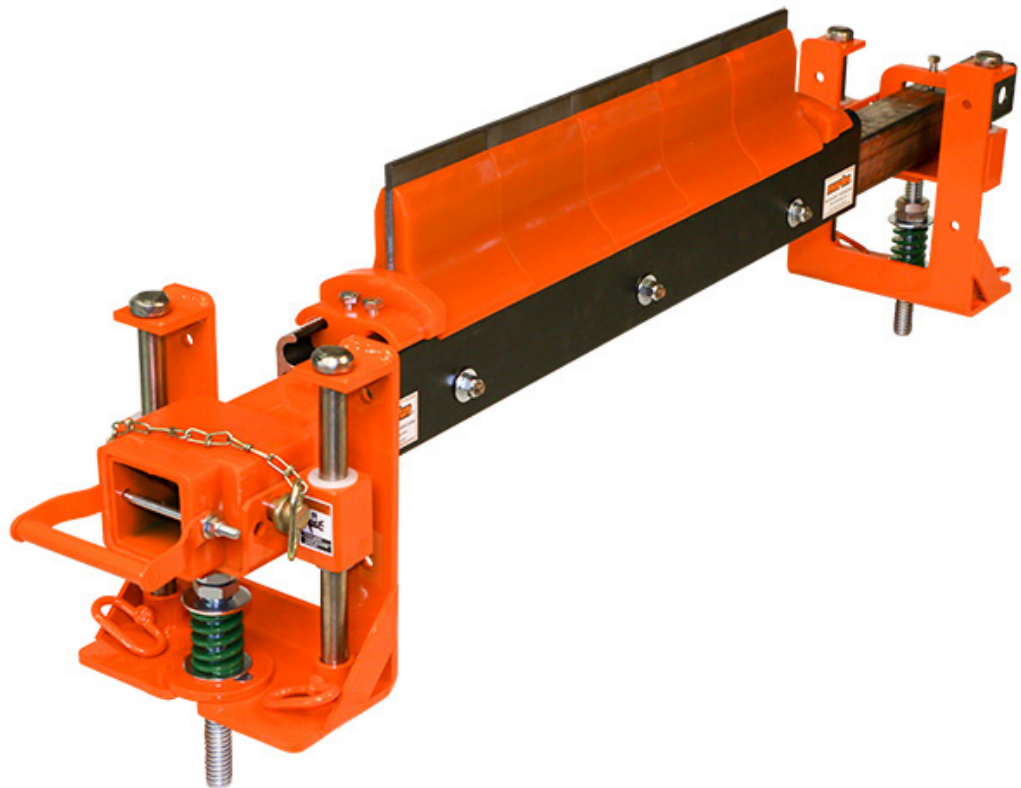

Operator's Manual
M3699

Important

MARTIN ENGINEERING HEREBY DISCLAIMS ANY LIABILITY FOR: DAMAGE DUE TO CONTAMINATION OF THE MATERIAL; USER'S FAILURE TO INSPECT, MAINTAIN AND TAKE REASONABLE CARE OF THE EQUIPMENT; INJURIES OR DAMAGE RESULTING FROM USE OR APPLICATION OF THIS PRODUCT CONTRARY TO INSTRUCTIONS AND SPECIFICATIONS CONTAINED HEREIN. MARTIN ENGINEERING'S LIABILITY SHALL BE LIMITED TO REPAIR OR REPLACEMENT OF EQUIPMENT SHOWN TO BE DEFECTIVE.

Observe all safety rules given herein along with owner and Government standards and regulations. Know and understand lockout/tagout procedures as defined by American National Standards Institute (ANSI) z244.1-1982, *American National Standard for Personnel Protection - Lockout/Tagout of Energy Sources - Minimum Safety Requirements* and Occupational Safety and Health Administration (OSHA) Federal Register, Part IV, 29 CFR Part 1910, *Control of Hazardous Energy Source (Lockout/Tagout); Final Rule*.

The following symbols may be used in this manual:



Danger: Immediate hazards that will result in severe personal injury or death.



Warning: Hazards or unsafe practices that could result in personal injury.



Caution: Hazards or unsafe practices that could result in product or property damages.



Important: Instructions that must be followed to ensure proper installation/operation of equipment.



Note: General statements to assist the reader.

Table of Contents

Section	Page
List of Figures/Tables	ii
Introduction	1
General	1
Installations Without Chutework	1
Belt Cleaner Inspection Access	1
References	1
Materials Required	1
Urethane Shelf Life	2
Safety	3
Before Installing Belt Cleaner	4
Installing Belt Cleaner	5
Locating Cleaner Centerline	6
Marking Chute Cutouts	7
Adjusting the Spring Tensioner	11
After Installing Belt Cleaner	15
Weekly Maintenance	17
Troubleshooting/Installation Checklist	19
Part Numbers	21

List of Figures

Figure	Title	Page
1	Primary Belt Direction	6
2	Chute Cutouts	7
3a	Cleaner Changing Belt Line	15
3b	Cleaner with Belt Support	15
4	Martin® DT2H Reversing Cleaner XHD Assembly, P/N DT2H-XXXXXXXXXX with Air Tensioner P/N 37806-A	22
5	Martin® DT2H Reversing Cleaner XHD Assembly, P/N DT2H-XXXXXXXXXX with Spring Tensioner P/N 37806	26
6	Martin® DT2H Reversing Cleaner XHD Cartridge, P/N DT2HC-XXXXXXXXXX .	30
7	Conveyor Products Warning Label, P/N 23395	33
8	Pinch Point Warning Label, P/N 30528	33

List of Tables

Table	Title	Page
I	Urethane Shelf Life	2
II	Recommended Spring Tension.	13
III	Martin® DT2H Reversing Cleaner XHD Assembly with Air Tensioner	24
IV	Martin® DT2H Reversing Cleaner XHD Assembly with Spring Tensioner	28
V	Martin® DT2H Reversing Cleaner XHD Cartridge Part Numbers and Dimensions .	31

Introduction

General

The Martin[®] DT2H Reversing Cleaner XHD is used in conjunction with a head pulley primary cleaner such as the Martin[®] Primary Cleaners. To introduce product back into the product flow, a Pre-Cleaner is installed on the face of the head pulley. On a dual cleaner system, the Secondary Cleaner is installed immediately following the Pre-Cleaner to remove stubborn material left on the conveyor belt. If a Pre-Cleaner cannot be used because of space limitations, the Secondary Cleaner is installed alone. If the material-handling process or product could be affected by contamination from the use of these belt cleaners, the user is responsible for taking the necessary steps to prevent contamination. Consult Martin Engineering or a representative for alternate belt cleaners or belt cleaner locations to use where contamination may be an issue.

The Martin[®] DT2H Reversing Cleaner XHD contacts the belt as it leaves the head pulley or another accessible position on the return belt with proper support. The blades of the Martin[®] DT2H Reversing Cleaner XHD, when tensioned, lay in the direction of belt travel giving a negative angle and presenting no snag or danger to the belt or splices.

Installations Without Chutework

These procedures were written for equipment that is being installed on enclosed pulley chutework. If the pulley is not enclosed, the equipment should be installed using the best available field resources and methods to ensure that the critical dimensions are followed for proper installation.

Belt Cleaner Inspection Access

If the belt cleaner is installed on enclosed pulley chutework, a Martin[®] Inspection Door should be installed. Martin[®] Inspection Doors are available from Martin Engineering or your representative.

References

The following documents are referenced in this manual:

- American National Standards Institute (ANSI) z244.1-1982, *American National Standard for Personnel Protection - Lockout/Tagout of Energy Sources - Minimum Safety Requirements*, American National Standards Institute, Inc., 1430 Broadway, New York, NY 10018.
- Federal Register, Volume 54, Number 169, Part IV, 29 CFR Part 1910, *Control of Hazardous Energy Source (Lockout/Tagout); Final Rule*, Department of Labor, Occupational Safety and Health Administration (OSHA), 32nd Floor, Room 3244, 230 South Dearborn Street, Chicago, IL 60604.
- *Martin[®] Inspection Door Operator's Manual*, P/N M3891.

Materials Required

Only standard hand tools are required to install and service this equipment.

Urethane Shelf Life

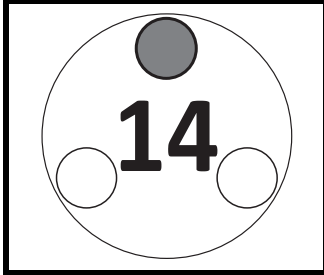

IMPORTANT

Urethane put in service after exceeding its shelf life may wear differently and deteriorate quicker than normal urethane.

NOTE

Code Date is written near bottom of blade as mm/dd/yy-x. In addition to or in place of this date, you may see an imprinted date medallion similar to the example shown. In this example, “14” stands for the year 2014. The small circles represent the quarter of the year. If three circles are “punched” the blade was produced in the first quarter. If none of the circles are “punched” the blade was produced in the fourth quarter. If code date on your blade(s) is not legible or is missing, contact Martin Engineering or a representative.

Table I. Urethane Shelf Life

Blade Color	Shelf Life
Blue	1 Year from Code Date
Brown	2 Years from Code Date
Clear	1 Year from Code Date
Green	2 Years from Code Date
Orange	1 Year from Code Date

Safety

All safety rules defined in the above documents and all owner/employer safety rules must be strictly followed when working on the belt cleaner.



⚠ DANGER

Do not touch or go near the conveyor belt or conveyor accessories when the belt is running. Your body or clothing can get caught and you can be pulled into the conveyor, resulting in severe injury or death.



⚠ DANGER

Before installing, servicing, or adjusting the belt cleaner, turn off and lockout / tagout / blockout / testout all energy sources to the conveyor and conveyor accessories according to ANSI standards. Failure to do so could result in serious injury or death.

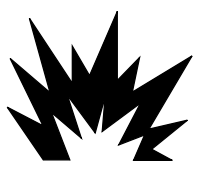

⚠ DANGER

If this equipment will be installed in an enclosed area, test the gas level or dust content before using a cutting torch or welding. Using a torch or welding in an area with gas or dust may cause an explosion resulting in serious injury or death. Follow local confined space procedures.



⚠ WARNING

Before using a cutting torch or welding the chute wall, cover the conveyor belt with a fire retardant cover. Failure to do so can allow the belt to catch fire. Follow local fire watch procedures.

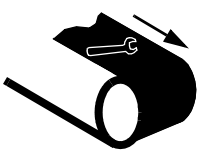

⚠ WARNING

Remove all tools from the installation area and conveyor belt before turning on the conveyor. Failure to do so can cause serious injury to personnel or damage to the belt and conveyor.



⚠ WARNING

Mainframe with blade can be heavy and may require two people to lift. Attempting to lift the belt cleaner without assistance could result in injury.

Before Installing Belt Cleaner

IMPORTANT

The delivery service is responsible for damage occurring in transit. Martin Engineering CANNOT enter claims for damages. Contact your transportation agent for more information.

1. Inspect shipping container for damage. Report damage to delivery service immediately and fill out delivery service's claim form. Keep any damaged goods subject to examination.
2. Remove belt cleaner from shipping container. Equipment in container should include the following:
 - Martin® DT2H Reversing Cleaner XHD (mainframe, tensioner, and blades).
 - Two Conveyor Products Warning Labels, P/N 23395.
 - Two Pinch Point Warning Labels, P/N 30528.



⚠ DANGER

Before installing, servicing, or adjusting the belt cleaner, turn off and lockout / tagout / blockout / testout all energy sources to the conveyor and conveyor accessories according to ANSI standards. Failure to do so could result in serious injury or death.

3. Turn off and lockout / tagout / blockout / testout energy source according to ANSI standards (see "References").

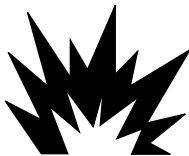

⚠ DANGER

If this equipment will be installed in an enclosed area, test the gas level or dust content before using a cutting torch or welding. Using a torch or welding in an area with gas or dust may cause an explosion resulting in serious injury or death. Follow local confined space procedures.

4. If using a cutting torch or welding, test atmosphere for gas level or dust content. Cover conveyor belt with fire retardant cover.

NOTE

The chute wall that is easiest to access is referred to as the "operator side." The other side of the chute is referred to as the "far side."

5. Determine which side of chute is easiest to access. Locate the operator side tensioner on the most accessible chute wall and the far side tensioner on the other side of the chute.

Installing Belt Cleaner

IMPORTANT

Read entire section before beginning work.

To install the belt cleaner, follow the procedures corresponding to the following steps:

▲ WARNING

If installation is to be done in an enclosed area, test atmosphere for gas level or dust content. Follow all welding and safety guidelines. Protect belt surface from weld splatter with appropriate shield.

NOTE

For original equipment installation, where cleaner cutouts and brackets have been fabricated into the chute during construction, ignore steps 1, 2 and 3.

NOTE

Solid backing of the blade is essential to ensure proper operation and efficient cleaning. Install the cleaner adjacent to the head pulley or a flat pressure roller to obtain best cleaning results. See Figure 1.

NOTE

For installation on enclosed head pulley chutework, draw all dimension lines on chute wall. In applications where head pulley is not enclosed, use the best available field resources and/or methods to ensure that these critical dimensions are followed for a proper installation.

Locating Cleaner Centerline

1. On the return side of the belt, locate the tangent point at which the belt leaves the head pulley. Measure a distance 2.0 in. (51 mm) and draw a line perpendicular to the belt at this point. See Figure 1.

NOTE

For installation below pressure rollers, mark the vertical line 2 in. (51 mm) from the centerline of the roller. See Figure 1.

2. This line represents the centerline of the Martin® DT2H Reversing Cleaner XHD and the cleaner mount brackets.

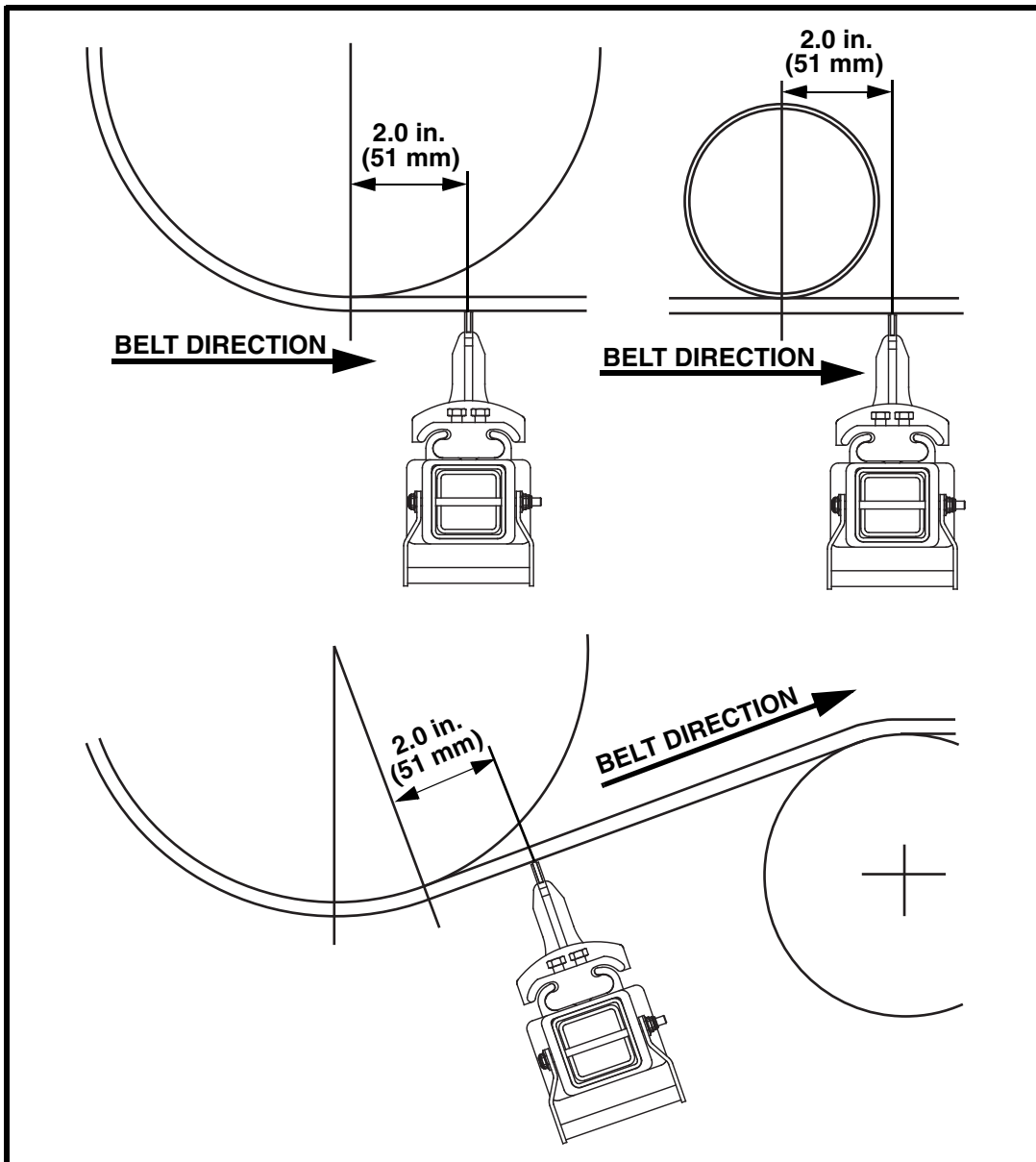

Figure 1. Primary Belt Direction

Marking Chute Cutouts

- Using the previously marked line as the centerline, mark the chute cutout and mount hole locations as shown in Figure 2. Repeat on both sides of chute, ensuring the cutouts are accurately aligned with each other.

NOTE

Note: The location of the mounting holes differs according to blade type. Make sure that you are using correct dimensions and verify cleaner position before proceeding.

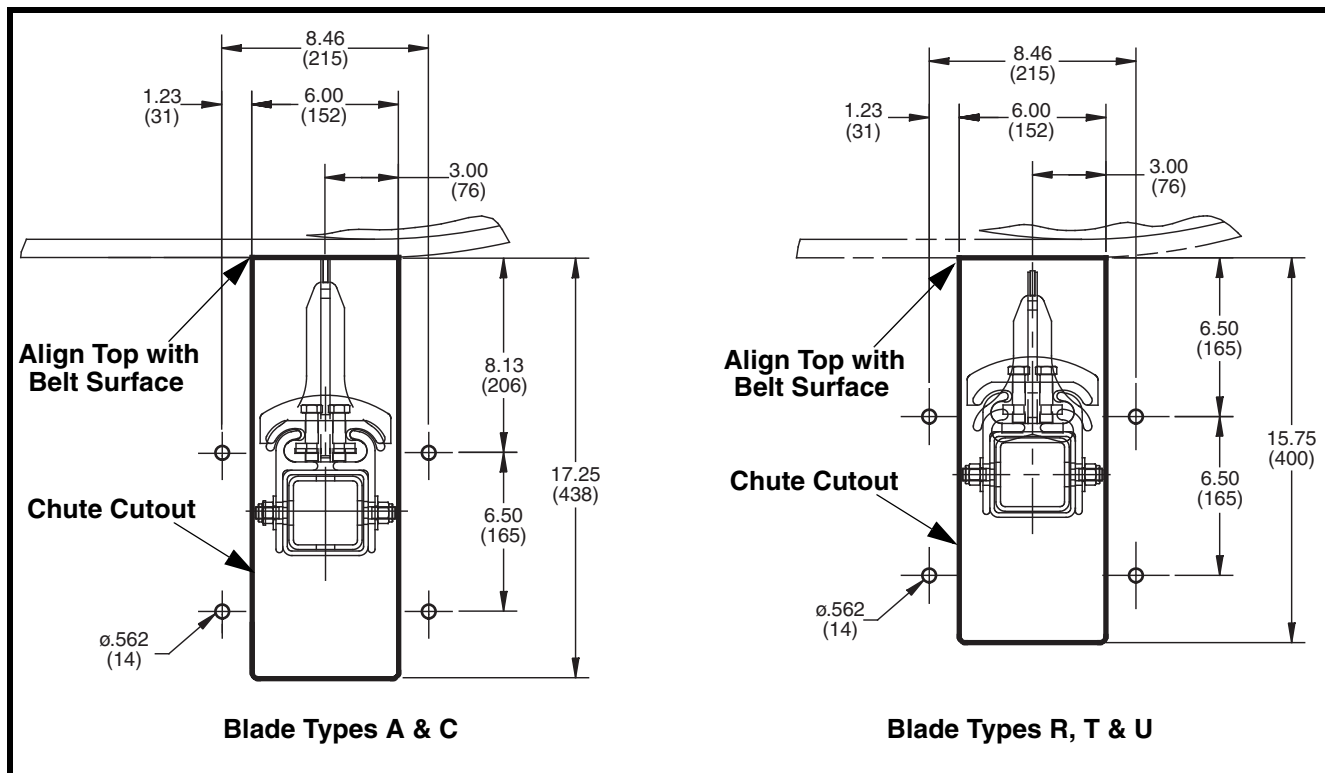
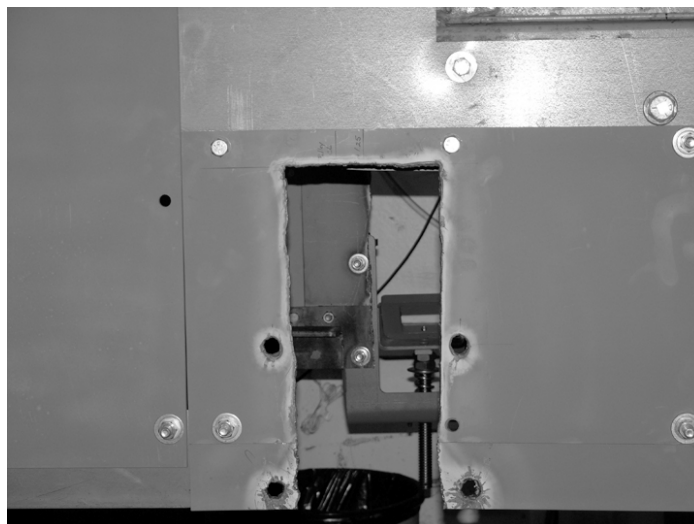

Figure 2. Chute Cutouts



2. At the selected mounting positions, cut the cleaner access slots and drill the mount holes in each side of the chute. Dress and de-burr the holes and cutouts.



3. Fit operator side mount bracket to the chute wall. Bolt mount to the chute wall.
4. Repeat for far side mount bracket.





5. Fit the mainframe mandrel to the mounts. Slide the mandrel into one of the mount brackets through the cutout in the chute wall, then through the cutout and mount on the opposite side.



6. On the far side, snug down the 3 set screws to keep mandrel from sliding while installing mainframe.

NOTE

The mainframe mandrel has holes at one end. This is the end that fastens to the operator side mount.

NOTE

The mainframe mandrel will have excess length in most cases. If required, this excess can be trimmed from the far side end.

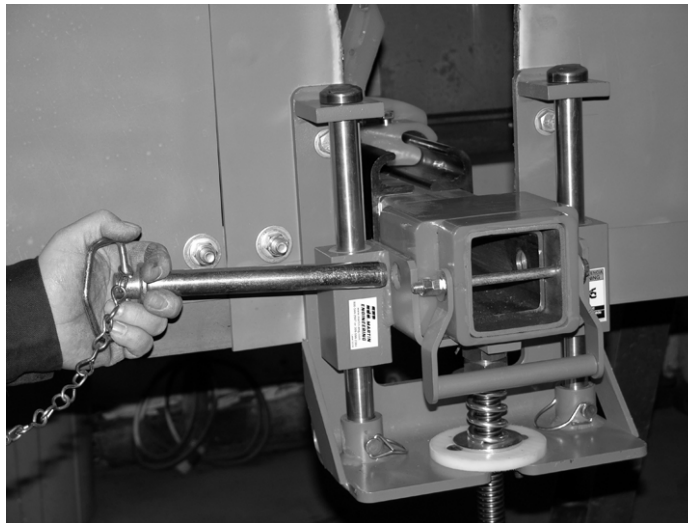

7. Slide blade cartridge onto mainframe mandrel. Loosen set screws on mandrel and align holes in mandrel, blade cartridge and slide bracket.
8. Center blades to the belt by loosening end stops and split frame and repositioning blades. Retighten.
9. Thoroughly check all mounting and locking screws to ensure they are tight and the cleaner is secured.
10. Installation is now complete. See instructions for adjusting cleaner against the belt.

Adjusting the Spring Tensioner



1. Loosen the locking nut above the spring. Repeat for both sides.



2. Turn adjusting nut (equally on both sides) until cleaner blades are lightly touching the belt.
3. Ensure the blade position is equal across belt and blades are lightly touching across belt width.



4. Continue turning the adjusting nut equally on both sides until the spring compressed length is the same as indicated in Table II.
5. Start the conveyor and observe the cleaning action of the blades. Ensure the blades ride smoothly on the belt with no vibration.

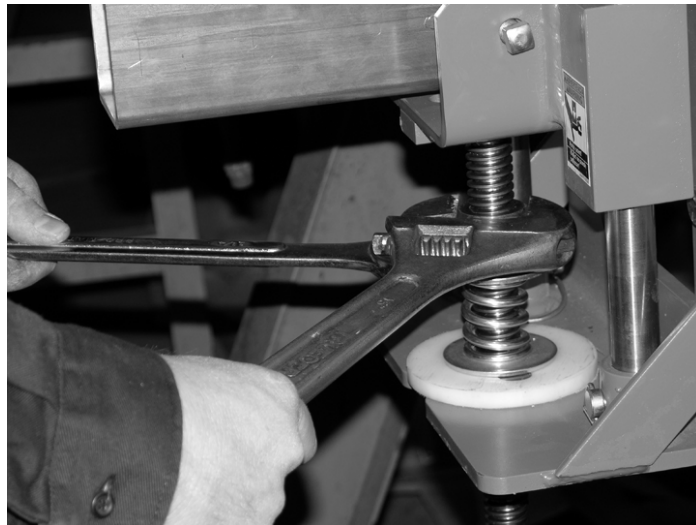

6. Tighten the locknuts against the adjusting nuts.

Table II. Recommended Spring Tension

Belt Width in. (mm)	Compressed Spring Length in. (mm)	Air/Water Tensioner psi (bar)	Number of Full Turns
18 (400-500)	2.250 (57)	13 (0.90)	1
24 (500-650)	2.125 (54)	16 (1.10)	2
30 (650-800)	2.125 (54)	18 (1.24)	2
36 (800-1000)	2.000 (51)	20 (1.38)	3
42 (1000-1200)	2.000 (51)	23 (1.59)	3
48 (1200-1400)	1.875 (48)	25 (1.72)	4
54 (1400-1600)	*2.250 (57)	27 (1.86)	*1
60 (1600-1800)	*2.125 (54)	29 (2.00)	*2
72 (1800-2000)	*2.125 (54)	33 (2.28)	*2
84 (2000-2200)	*2.125 (54)	38 (2.62)	*2
96 (2200-2400)	*2.000 (51)	42 (2.90)	*3
102 (2400-2600)	*2.000 (51)	45 (3.10)	*3
108 (2600-2800)	*2.000 (51)	48 (3.31)	*3
120 (2800-3000)	*1.875 (48)	51 (3.52)	*4

*For belt widths 54-inch and above use green spring.

Installation

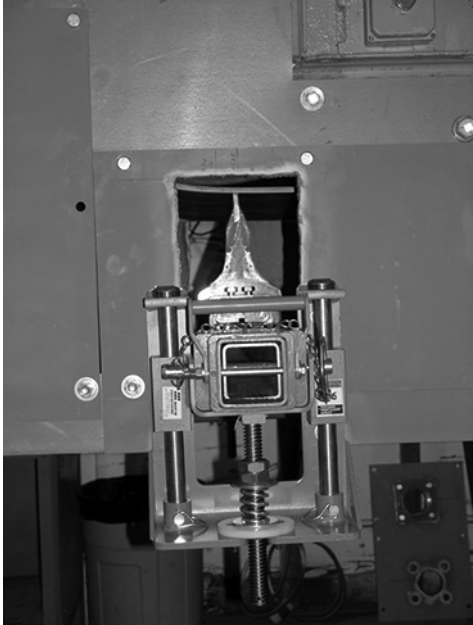

After Installing Belt Cleaner

IMPORTANT

Read entire section before beginning work.

1. After belt cleaner and tensioner are installed, measure from pulley shaft to mainframe on both operator side and far side to make sure mainframe is parallel to pulley.
2. Measure from center point of pulley to outside edge of first and last blade to make sure blades are centered on belt.
3. Make sure cleaner is not changing belt line (Figure 3a). If it is, install belt support ahead of blade-to-belt contact point (Figure 3b).

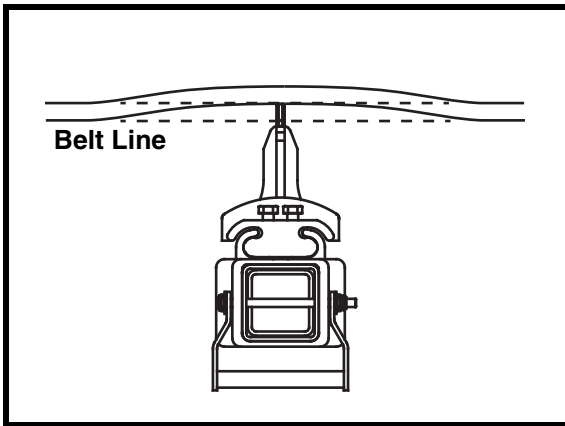

Figure 3a. Cleaner Changing Belt Line

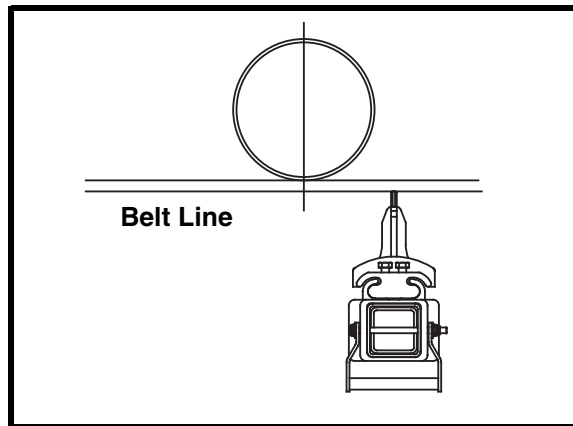

Figure 3b. Cleaner with Belt Support

4. Thoroughly wipe outside chute walls clean above tensioners on both sides of chute. Place Conveyor Products Warning Label (P/N 23395) on chute walls or where it will be visible to belt cleaner operator.

WARNING

Failure to remove tools from installation area and conveyor belt before turning on energy source can cause serious injury to personnel and damage to belt.

5. Remove all tools and fire retardant cover from installation area and conveyor belt.

DANGER

Do not touch or go near conveyor belt or conveyor accessories when conveyor belt is running. Body or clothing can get caught and pull body into conveyor belt, causing severe injury or death.

6. Turn on conveyor belt for 1 hour.

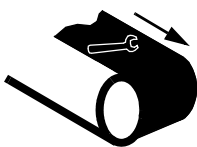



⚠ DANGER

Before installing, servicing, or adjusting the belt cleaner, turn off and lockout / tagout / blockout / testout all energy sources to the conveyor and conveyor accessories according to ANSI standards. Failure to do so could result in serious injury or death.

7. After 1 hour of operation, turn off and lockout / tagout / blockout / testout energy source according to ANSI standards (see “References”).
8. Make sure all fasteners are tight. Tighten if necessary.
9. Inspect belt cleaner for the following:
 - Wear. (A small amount of “break-in” wear may be found.)
 - Material buildup. (No material between blades and return side of conveyor belt should be found.)
10. If wear, material buildup, or some other problem exists, see “Troubleshooting/Installation Checklist.”

NOTE

Maintenance inspections should be performed weekly until a maintenance schedule can be determined. Certain applications and/or changing material conditions may require more frequent maintenance inspections.



Routine Inspection/ Tension

1. Inspect the condition of the cleaner. Open the inspection door (if fitted) and observe the condition and action of the blades and cleaner.
2. Remove any material buildup from the blades or mainframe.

⚠ DANGER

Before installing, servicing, or adjusting the belt cleaner, turn off and lockout / tagout / blockout / testout all energy sources to the conveyor and conveyor accessories according to ANSI standards. Failure to do so could result in serious injury or death.

⚠ WARNING

Do not reach into the chute while the conveyor is running.

3. If necessary, adjust the cleaner tension. Refer to appropriate section for tensioner used.
4. Make sure all fasteners are tight. Tighten if necessary.
5. Check blades for wear. If blades are worn to wear line, replace blades.
6. Wipe warning labels clean. If labels are not readable, contact Martin Engineering or a representative for replacements.



Blade Servicing

1. Shut down and lockout / tagout / blockout / testout conveyor.
2. Undo tensioner and visually inspect blades.
 - a. If blades are clean and not excessively worn, re-tension cleaner.
 - b. If material buildup is still present or blades are worn excessively, proceed.
3. When fully retracted, simply remove the retaining pin securing the blade cartridge to the operator end of the mainframe mandrel. Grasp the handle and pull the blade cartridge off the mandrel and away from the mount bracket. Completely remove the blade cartridge from the mainframe mandrel and place it in a suitable position for maintenance work to be carried out.

⚠ DANGER

Before installing, servicing, or adjusting the belt cleaner, turn off and lockout / tagout / blockout / testout all energy sources to the conveyor and conveyor accessories according to ANSI standards. Failure to do so could result in serious injury or death.

4. Clean and inspect the blades. If blades are excessively worn, replace with new blades. Remove the blades from the cartridge by removing one of the end stops and loosening the split track. Slide the blades out of the cartridge and replace by sliding in new blades. Ensure the blades face in the correct direction. Re-fit the end stop.
5. Re-install blade cartridge onto the cleaner mainframe mandrel and re-fit the securing pin at the operator side. Re-tension the cleaner.
6. Remove equipment from service if there is any indication it is not functioning properly. Call Martin Engineering or representative for assistance. Do NOT return equipment to operation until the cause of the problem has been identified and corrected.

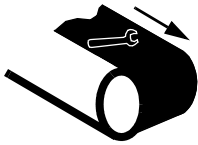

⚠ WARNING

Failure to remove tools from installation area and conveyor belt before turning on energy source can cause serious injury to personnel and damage to belt.

7. Remove all tools and fire retardant cover from installation area and conveyor belt.

⚠ DANGER

Do not touch or go near conveyor belt or conveyor accessories when conveyor belt is running. Body or clothing can get caught and pull body into conveyor belt, causing severe injury or death.



8. Start conveyor belt.
9. Observe cleaner action and blade effectiveness.

Troubleshooting/Installation Checklist

Troubleshooting If you are experiencing problems with belt cleaner, see below:

Symptom	Corrective Action
Blades pop out of track.	Tension is set too high. Reduce pressure or tension.
High blade wear rate.	Tension is set too high. Reduce pressure or tension.
Insufficient cleaning and carryback.	<ul style="list-style-type: none"> • Tension is set too low or too high. Increase or decrease pressure or tension. • Check blades for excessive wear and replace if necessary.
Blades vibrate.	<ul style="list-style-type: none"> • Incorrect installation angle. Check installation, ensuring cleaner mount is perpendicular to belt. • Belt deflected upward on tensioning of cleaner. Install an idler roller over the belt near the blade contact point. • Belt vibration being transferred to cleaner. Install an idler roller over the belt near the blade contact point.

NOTE

Conveyor equipment such as conveyor belt cleaners are subject to a wide variety of bulk materials characteristics and often have to perform under extreme operating or environmental conditions. It is not possible to predict all circumstances that may require troubleshooting. Contact Martin Engineering or a representative if you are experiencing problems other than those listed in the “Troubleshooting” chart above. Do not return the equipment to operation until the problem has been identified and corrected.

Installation checklist If after taking corrective actions suggested under “Troubleshooting” you are still experiencing problems, check for the following:

Installation Checklist
- Mainframe is parallel to pulley.
- Blades are perpendicular to belt.
- Blades are centered on belt.

Part Numbers

This section provides product names and corresponding part numbers for Martin® DT2H Reversing Cleaner XHD and related equipment. Please reference part numbers when ordering parts:

Martin® DT2H Reversing Cleaner XHD Assembly

Martin® DT2H Reversing Cleaner XHD Assembly with Air Tensioner:
P/N DT2H-XXXXXXXXXA. (See Figure 4)

Martin® DT2H Reversing Cleaner XHD Assembly with Spring Tensioner: P/N DT2H-XXXXXXXXXS. (See Figure 5)

NOMENCLATURE

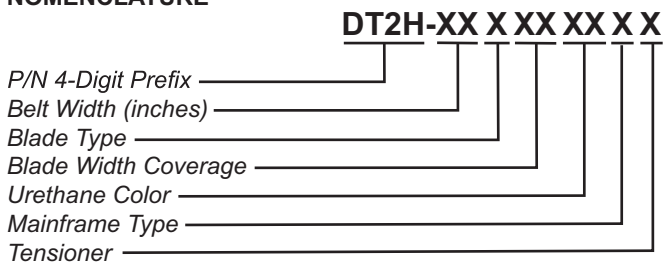

Blade Type

- A:** Tungsten Carbide Tall Blade
- C:** Tungsten Carbide Tall Blade with SS Upright
- R:** Tungsten Carbide Blade with SS Upright
- T:** Tungsten Carbide Blade
- U:** Urethane Blade

Mainframe

- P:** Painted
- S:** 316 Stainless Steel

Tensioner

- A:** Air Tensioner
- S:** Spring Tensioner

Urethane Color

- BR:** Brown
- GR:** Green
- OR:** Orange

Martin® DT2H Reversing Cleaner XHD Cartridge

Martin® DT2H Reversing Cleaner XHD Cartridge:
P/N DT2HC-XXXXXXXXX. (See Figure 6.)

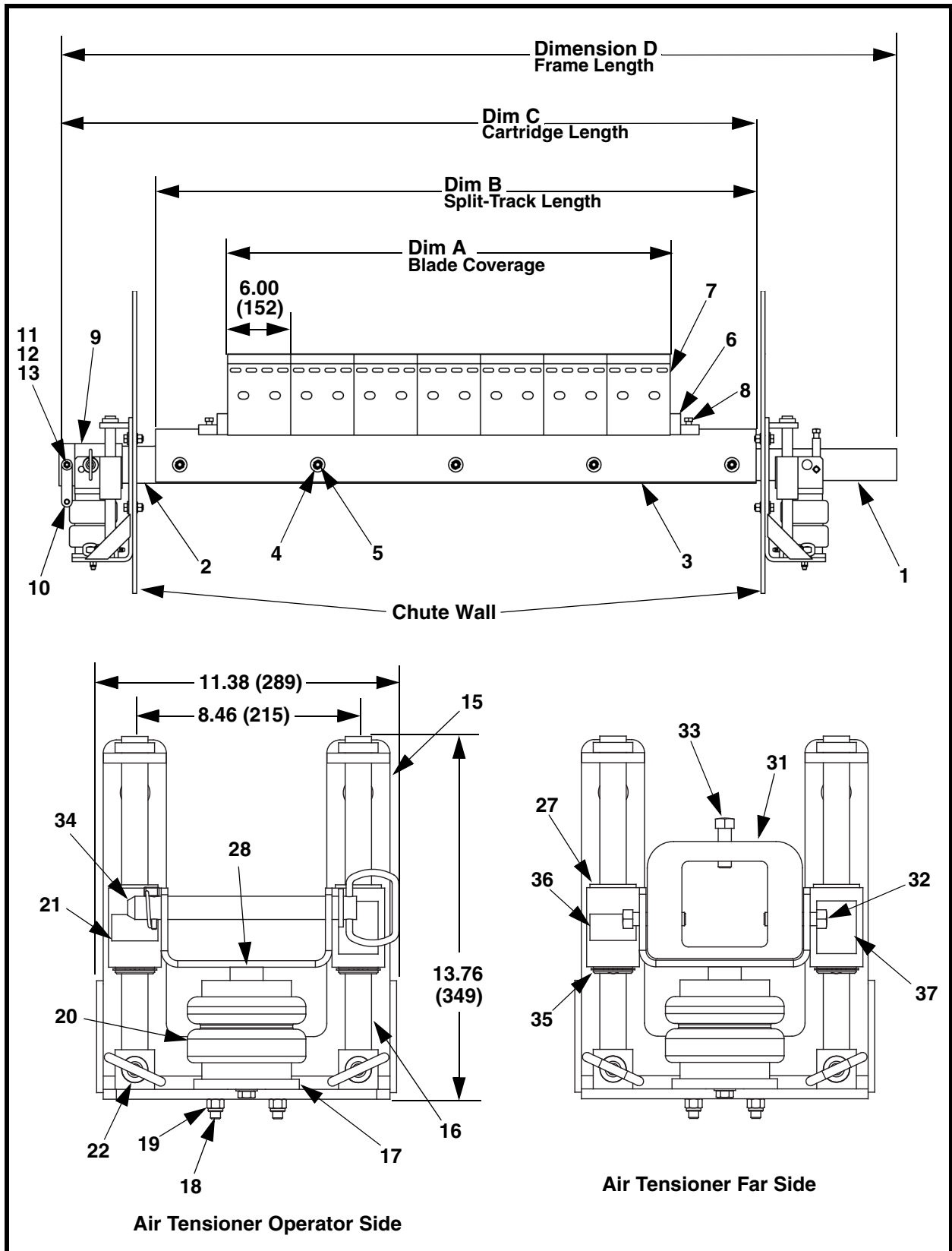

Figure 4. Martin[®] DT2H Reversing Cleaner XHD Assembly, P/N DT2H-XXXXXXXXXX with Air Tensioner, P/N 37806-A

Item	Description	Part No.	Qty
1	Frame Mandrel	37802-XX	1
2	XHD Split-Track Mainframe	37801-XX	1
3	DT XHD Split Frame	37803-XX	2
4	Washer Flat 1/2 Wide ZP	17328	Table III
5	Nut Hex Elastic Lock 1/2-13NC ZP	18577	Table III
6	XHD DT End Stop	32174-01	2
7	XHD Secondary Blade	Table III	Table III
8	Screw HHC 1/2-13NC X 2 ZP	14196	4
9	End Cap	37805	1
10	Handle Weldment	37211	1
11	Washer Flat 3/8 Wide ZP	18007	2
12	Screw HHC 3/8-16NC X 6 ZP	37834	1
13	Nut Hex Elastic Lock 3/8-16NC ZP	14201	1
14	XHD Air Tensioner	37806-A	1
15	Tensioner Mount Plate Weldment	37807	2
16	Tensioner Guide Rod Weldment	37814	4
17	Tensioner Spring Retainer	37824	2
18	Tensioner Screw FHSC 3/8-16NC x 1.50	34223	4
19	Tensioner Nut Hex Elastic Lock 3/8-16NC ZP	14201	4
20	Tensioner Air Bag	32537	2
21	Tensioner Slide Bracket	37809	2
22	Tensioner Pin, Quick Release 3/8 X 2.00 ZP	38139	4
23 (NS)	Tensioner Flat Washer 1/2 Thick SS	19126	8
24 (NS)	Tensioner Screw HHC 1/2-13NC x 1-1/2 SS	22766	8
25 (NS)	Tensioner Washer Compression 1/2 SS	24310	8
26 (NS)	Tensioner Nut Hex 1/2-13NC SS	17151	8
27	Tensioner UHMW Sleeve	37704	4
28	Tensioner Screw SHC 3/8-16NC x 3/4 ZP	36510	4
29 (NS)	Tensioner Washer Compression 3/8	11747	4
30 (NS)	Tensioner Screw HHC 3/8-16NC x 1 ZP	11746-02	4
31	Tensioner Far Side Strap	37811	1
32	Tensioner Screw SHS 1/2-13NC x 2 SS	22763-06	2
33	Tensioner Screw SHS 1/2-13NC x 1-1/2 SS	33190	1
34	Tensioner Pin, Hitch 1/2 X 5-3/4	37818	1
35	External Retaining Ring for 1.50 Shaft	38301	4

Item	Description	Part No.	Qty
36	Label Martin Products	38048	2
37	Label Pinch Point Warning	30528	2
38 (NS)	Label Conveyor Products Warning	23395	2
39 (NS)	Label Martin Tensioner	37827	2
40 (NS)	Manual, Operator's	M3699	1

NS=Not Shown

Figure 4. Martin® DT2H Reversing Cleaner XHD Assembly, P/N DT2H-XXXXXXXXXX with Air Tensioner, P/N 37806-A

Table III. Martin® DT2H Reversing Cleaner XHD Assembly with Air Tensioner

Part No. Heavy-Duty Mainframe	Dim A	Dim B	Dim C	Dim D
DT2H-18X12XXXX	12.00 (305)	27.00 (686)	36.16 (918)	49.50 (1257)
DT2H-18X18XXXX	18.00 (457)	27.00 (686)	36.16 (918)	49.50 (1257)
DT2H-24X18XXXX	18.00 (457)	33.00 (838)	42.16 (1071)	55.50 (1410)
DT2H-24X24XXXX	24.00 (610)	33.00 (838)	42.16 (1071)	55.50 (1410)
DT2H-30X24XXXX	24.00 (610)	39.00 (991)	48.16 (1223)	61.50 (1562)
DT2H-30X30XXXX	30.00 (762)	39.00 (991)	48.16 (1223)	61.50 (1562)
DT2H-36X30XXXX	30.00 (762)	45.00 (1143)	54.16 (1376)	67.50 (1715)
DT2H-36X36XXXX	36.00 (914)	45.00 (1143)	54.16 (1376)	67.50 (1715)
DT2H-42X36XXXX	36.00 (914)	51.00 (1295)	60.16 (1528)	73.50 (1867)
DT2H-42X42XXXX	42.00 (1067)	51.00 (1295)	60.16 (1528)	73.50 (1867)
DT2H-48X42XXXX	42.00 (1067)	57.00 (1448)	66.16 (1680)	79.50 (2019)
DT2H-48X48XXXX	48.00 (1219)	57.00 (1448)	66.16 (1680)	79.50 (2019)
DT2H-54X48XXXX	48.00 (1219)	63.00 (1600)	72.16 (1833)	85.50 (2172)
DT2H-54X54XXXX	54.00 (1372)	63.00 (1600)	72.16 (1833)	85.50 (2172)
DT2H-60X54XXXX	54.00 (1372)	69.00 (1753)	78.16 (1985)	91.50 (2324)
DT2H-60X60XXXX	60.00 (1524)	69.00 (1753)	78.16 (1985)	91.50 (2324)
DT2H-66X60XXXX	60.00 (1524)	75.00 (1905)	84.16 (2138)	97.50 (2477)
DT2H-66X66XXXX	66.00 (1676)	75.00 (1905)	84.16 (2138)	97.50 (2477)
DT2H-72X66XXXX	66.00 (1676)	81.00 (2057)	90.16 (2290)	103.50 (2629)
DT2H-84X72XXXX	72.00 (1829)	93.00 (2362)	102.16 (2595)	115.50 (2934)
DT2H-84X78XXXX	78.00 (1981)	93.00 (2362)	102.16 (2595)	115.50 (2934)
DT2H-96X90XXXX	90.00 (2286)	105.00 (2667)	114.16 (2900)	127.50 (3239)
DT2H-102X96XXXX	96.00 (2438)	111.00 (2819)	120.16 (3052)	133.50 (3391)
DT2H-114X108XXXX	108.00 (2743)	123.00 (3124)	132.16 (3357)	145.50 (3696)

Table III. (continued)

Part No. Heavy-Duty Mainframe	Part No. Item 1	Part No. Item 2	Part No. Item 3	Qty. Items 4 and 5	Qty. Item 7	Weight w/o Tens. (lbs)
DT2H-18X12XXXX	37802-18	37801-18	37803-18	4	2	84.3
DT2H-18X18XXXX	37802-18	37801-18	37803-18	4	3	91.3
DT2H-24X18XXXX	37802-24	37801-24	37803-24	6	3	101.3
DT2H-24X24XXXX	37802-24	37801-24	37803-24	6	4	108.3
DT2H-30X24XXXX	37802-30	37801-30	37803-30	6	4	118.5
DT2H-30X30XXXX	37802-30	37801-30	37803-30	6	5	125.5
DT2H-36X30XXXX	37802-36	37801-36	37803-36	8	5	135.5
DT2H-36X36XXXX	37802-36	37801-36	37803-36	8	6	142.5
DT2H-42X36XXXX	37802-42	37801-42	37803-42	8	6	152.7
DT2H-42X42XXXX	37802-42	37801-42	37803-42	8	7	159.7
DT2H-48X42XXXX	37802-48	37801-48	37803-48	10	7	169.7
DT2H-48X48XXXX	37802-48	37801-48	37803-48	10	8	176.7
DT2H-54X48XXXX	37802-54	37801-54	37803-54	10	8	186.9
DT2H-54X54XXXX	37802-54	37801-54	37803-54	10	9	193.9
DT2H-60X54XXXX	37802-60	37801-60	37803-60	10	9	203.9
DT2H-60X60XXXX	37802-60	37801-60	37803-60	10	10	210.9
DT2H-66X60XXXX	37802-66	37801-66	37803-66	12	10	221.1
DT2H-66X66XXXX	37802-66	37801-66	37803-66	12	11	228.1
DT2H-72X66XXXX	37802-72	37801-72	37803-72	12	11	238.1
DT2H-84X72XXXX	37802-84	37801-84	37803-84	14	12	265.9
DT2H-84X78XXXX	37802-84	37801-84	37803-84	14	13	272.3
DT2H-96X90XXXX	37802-96	37801-96	37803-96	16	15	306.6
DT2H-102X96XXXX	37802-102	37801-102	37803-102	18	16	324.2
DT2H-114X108XXXX	37802-114	37801-114	37803-114	20	18	358.7

Part Numbers

Blade Description	Blade Part No.	Part No. Item 7
Tall Tungsten Carbide	DT2H-XXAXXXXXXX	39539-T
Tall Tungsten Carbide with SS Upright	DT2H-XXCXXXXXX	39539-TSS
Tungsten Carbide with SS Upright	DT2H-XXRXXXXXX	32494-TSS
Tungsten Carbide	DT2H-XXTXXXXXX	32494-T
Urethane	DT2H-XXUXXXXXX	32494-06U

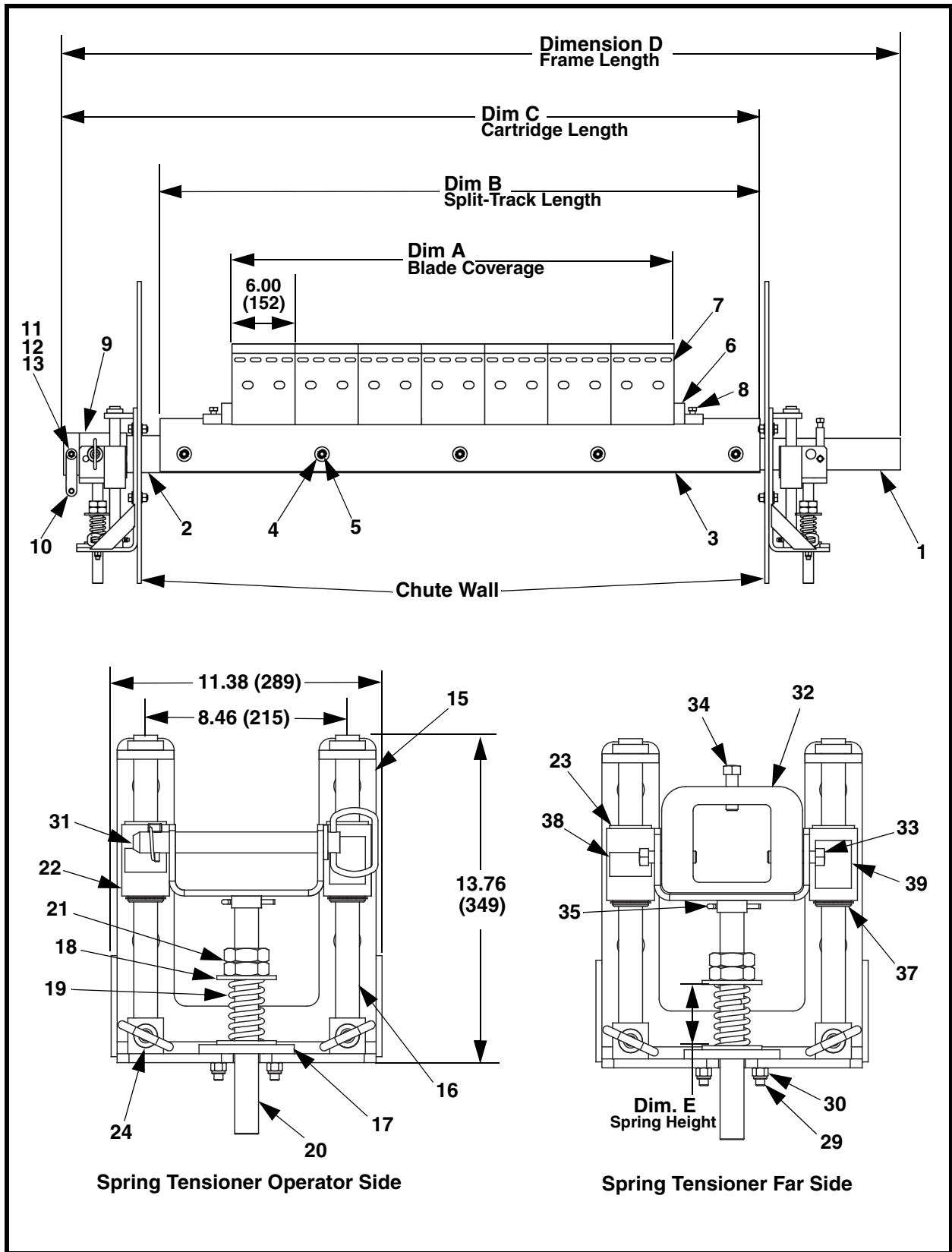

Figure 5. Martin[®] DT2H Reversing Cleaner XHD Assembly, P/N DT2H-XXXXXXXXXX with Spring Tensioner, P/N 37806

Item	Description	Part No.	Qty
1	Frame Mandrel	37802-XX	1
2	XHD Split-Track Mainframe	37801-XX	1
3	DT XHD Split Frame	37803-XX	2
4	Washer Flat 1/2 Wide ZP	17328	Table IV
5	Nut Hex Elastic Lock 1/2-13NC ZP	18577	Table IV
6	XHD DT End Stop	32174-01	2
7	XHD Secondary Blade	Table IV	Table IV
8	Screw HHC 1/2-13NC X 2 ZP	14196	4
9	End Cap	37805	1
10	Handle Weldment	37211	1
11	Washer Flat 3/8 Wide ZP	18007	2
12	Screw HHC 3/8-16NC X 6 ZP	37834	1
13	Nut Hex Elastic Lock 3/8-16NC ZP	14201	1
14	XHD Spring Tensioner	37806	1
15	Tensioner Mount Plate Weldment	37807	2
16	Tensioner Guide Rod Weldment	37814	4
17	Tensioner Spring Retainer	37824	2
18	Tensioner Flat Washer 1 Regular ZP	32315	Table IV
19	Tensioner Compression Spring	Table IV	2
20	Tensioner Rod Threaded 1-5 ACME Steel	37813	2
21	Tensioner Nut Hex Jam 1-5 ACME ZP	37873	4
22	Tensioner Slide Bracket	37809	2
23	Tensioner UHMW Sleeve	37704	4
24	Tensioner Pin, Quick Release 3/8 X 2.00 ZP	38139	4
25 (NS)	Tensioner Flat Washer 1/2 Thick SS	19126	8
26 (NS)	Tensioner Screw HHC 1/2-13NC x 1-1/2 SS	22766	8
27 (NS)	Tensioner Washer Compression 1/2 SS	24310	8
28 (NS)	Tensioner Nut Hex 1/2-13NC SS	17151	8
29	Tensioner Screw FSHC 3/8-16NC x 1.50	34223	4
30	Tensioner Nut Hex Elastic Lock 3/8-16NC ZP	14201	4
31	Tensioner Pin, Hitch 7/8 X 7.00	37818	1
32	Tensioner Far Side Strap	37811	1
33	Tensioner Screw SHS 1/2-13NC x 2 SS	22763-06	2
34	Tensioner Screw SHS 1/2-13NC x 1-1/2 SS	33190	1
35	Tensioner Cotter Pin 3/16 x 1-3/4 ZP	37880	2

Item	Description	Part No.	Qty
36 (NS)	Spring Die 2.00 x 2.50	37833	2
37	External Retaining Ring for 1.50 Shaft	38301	4
38	Label Martin Products	38048	2
39	Label Pinch Point Warning	30528	2
40 (NS)	Label Conveyor Products Warning	23395	2
41 (NS)	Label Martin Tensioner	37827	2
42 (NS)	Manual, Operator's	M3699	1

NS=Not Shown

Figure 5. Martin® DT2H Reversing Cleaner XHD Assembly, P/N DT2H-XXXXXXXXXX with Spring Tensioner, P/N 37806

Table IV. Martin® DT2H Reversing Cleaner XHD Assembly with Spring Tensioner

Part No. Heavy-Duty Mainframe	Dim A	Dim B	Dim C	Dim D
DT2H-18X12XXXX	12.00 (305)	27.00 (686)	36.16 (918)	49.50 (1257)
DT2H-18X18XXXX	18.00 (457)	27.00 (686)	36.16 (918)	49.50 (1257)
DT2H-24X18XXXX	18.00 (457)	33.00 (838)	42.16 (1071)	55.50 (1410)
DT2H-24X24XXXX	24.00 (610)	33.00 (838)	42.16 (1071)	55.50 (1410)
DT2H-30X24XXXX	24.00 (610)	39.00 (991)	48.16 (1223)	61.50 (1562)
DT2H-30X30XXXX	30.00 (762)	39.00 (991)	48.16 (1223)	61.50 (1562)
DT2H-36X30XXXX	30.00 (762)	45.00 (1143)	54.16 (1376)	67.50 (1715)
DT2H-36X36XXXX	36.00 (914)	45.00 (1143)	54.16 (1376)	67.50 (1715)
DT2H-42X36XXXX	36.00 (914)	51.00 (1295)	60.16 (1528)	73.50 (1867)
DT2H-42X42XXXX	42.00 (1067)	51.00 (1295)	60.16 (1528)	73.50 (1867)
DT2H-48X42XXXX	42.00 (1067)	57.00 (1448)	66.16 (1680)	79.50 (2019)
DT2H-48X48XXXX	48.00 (1219)	57.00 (1448)	66.16 (1680)	79.50 (2019)
DT2H-54X48XXXX	48.00 (1219)	63.00 (1600)	72.16 (1833)	85.50 (2172)
DT2H-54X54XXXX	54.00 (1372)	63.00 (1600)	72.16 (1833)	85.50 (2172)
DT2H-60X54XXXX	54.00 (1372)	69.00 (1753)	78.16 (1985)	91.50 (2324)
DT2H-60X60XXXX	60.00 (1524)	69.00 (1753)	78.16 (1985)	91.50 (2324)
DT2H-66X60XXXX	60.00 (1524)	75.00 (1905)	84.16 (2138)	97.50 (2477)
DT2H-66X66XXXX	66.00 (1676)	75.00 (1905)	84.16 (2138)	97.50 (2477)
DT2H-72X66XXXX	66.00 (1676)	81.00 (2057)	90.16 (2290)	103.50 (2629)
DT2H-84X72XXXX	72.00 (1829)	93.00 (2362)	102.16 (2595)	115.50 (2934)
DT2H-84X78XXXX	78.00 (1981)	93.00 (2362)	102.16 (2595)	115.50 (2934)
DT2H-96X90XXXX	90.00 (2286)	105.00 (2667)	114.16 (2900)	127.50 (3239)
DT2H-102X96XXXX	96.00 (2438)	111.00 (2819)	120.16 (3052)	133.50 (3391)
DT2H-114X108XXXX	108.00 (2743)	123.00 (3124)	132.16 (3357)	145.50 (3696)

Table IV. (continued)

Part No. Heavy-Duty Mainframe	Part No. Item 1	Part No. Item 2	Part No. Item 3	Qty. Items 4 and 5	Qty. Item 7	Weight w/o Tens. (lbs)
DT2H-18X12XXXX	37802-18	37801-18	37803-18	4	2	84.3
DT2H-18X18XXXX	37802-18	37801-18	37803-18	4	3	91.3
DT2H-24X18XXXX	37802-24	37801-24	37803-24	6	3	101.3
DT2H-24X24XXXX	37802-24	37801-24	37803-24	6	4	108.3
DT2H-30X24XXXX	37802-30	37801-30	37803-30	6	4	118.5
DT2H-30X30XXXX	37802-30	37801-30	37803-30	6	5	125.5
DT2H-36X30XXXX	37802-36	37801-36	37803-36	8	5	135.5
DT2H-36X36XXXX	37802-36	37801-36	37803-36	8	6	142.5
DT2H-42X36XXXX	37802-42	37801-42	37803-42	8	6	152.7
DT2H-42X42XXXX	37802-42	37801-42	37803-42	8	7	159.7
DT2H-48X42XXXX	37802-48	37801-48	37803-48	10	7	169.7
DT2H-48X48XXXX	37802-48	37801-48	37803-48	10	8	176.7
DT2H-54X48XXXX	37802-54	37801-54	37803-54	10	8	186.9
DT2H-54X54XXXX	37802-54	37801-54	37803-54	10	9	193.9
DT2H-60X54XXXX	37802-60	37801-60	37803-60	10	9	203.9
DT2H-60X60XXXX	37802-60	37801-60	37803-60	10	10	210.9
DT2H-66X60XXXX	37802-66	37801-66	37803-66	12	10	221.1
DT2H-66X66XXXX	37802-66	37801-66	37803-66	12	11	228.1
DT2H-72X66XXXX	37802-72	37801-72	37803-72	12	11	238.1
DT2H-84X72XXXX	37802-84	37801-84	37803-84	14	12	265.9
DT2H-84X78XXXX	37802-84	37801-84	37803-84	14	13	272.3
DT2H-96X90XXXX	37802-96	37801-96	37803-96	16	15	306.6
DT2H-102X96XXXX	37802-102	37801-102	37803-102	18	16	324.2
DT2H-114X108XXXX	37802-114	37801-114	37803-114	20	18	358.7

Belt Width	Part No. Item 19	Qty. Item 18	Dim. E
48.00 in. and below	37832	4	2.56 (65)
54.00 in. and above	37833	2	2.50 (64)

Blade Description	Blade Part No.	Part No. Item 7
Tall Tungsten Carbide	DT2H-XXAXXXXXXX	39539-T
Tall Tungsten Carbide with SS Upright	DT2H-XXCXXXXXX	39539-TSS
Tungsten Carbide with SS Upright	DT2H-XXRXXXXXX	32494-TSS
Tungsten Carbide	DT2H-XXTXXXXXX	32494-T
Urethane	DT2H-XXUXXXXXX	32494-06U

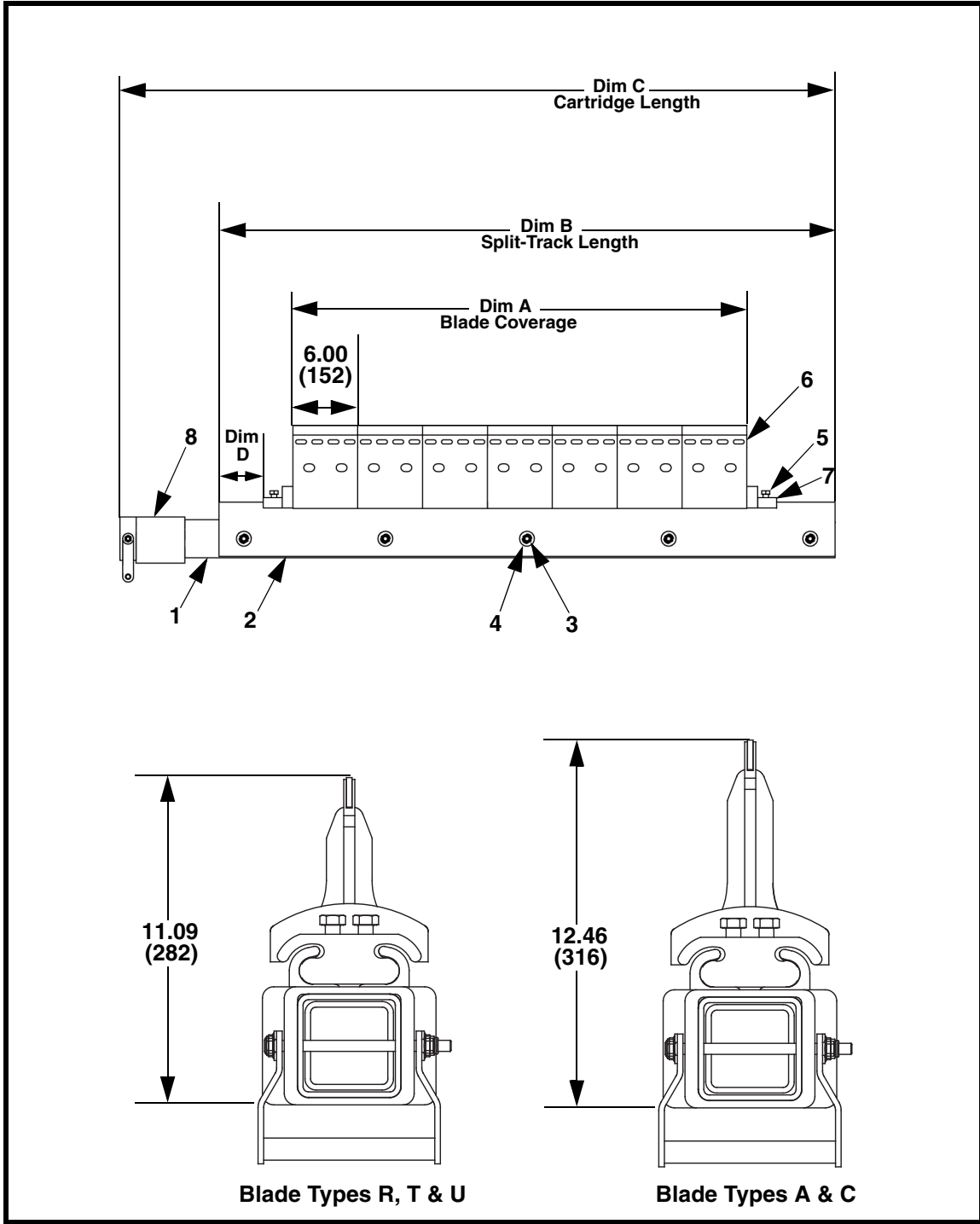

Figure 6. Martin[®] DT2H Reversing Cleaner XHD Cartridge, P/N DT2HC-XXXXXXXXXX

Item	Description	Part No.	Qty
1	XHD Split-Track Mainframe	37801-XX	1
2	DT XHD Split Frame	37803-XX	2
3	Washer Flat 1/2 Wide ZP	17328	Table V
4	Nut Hex Elastic Lock 1/2-13NC ZP	18577	Table V
5	XHD DT End Stop	32174-01	2
6	XHD Secondary Blade	Table V	Table V
7	Screw HHC 1/2-13NC X 2 ZP	14196	4
8	End Cap	37805	1
9	Handle Weldment	37211	1
10	Washer Flat 3/8 Wide ZP	18007	2
11	Screw HHC 3/8-16NC X 6 ZP	37834	1
12	Nut Hex Elastic Lock 3/8-16NC ZP	14201	1
13 (NS)	Label Conveyor Products Warning	23395	2
14 (NS)	Label Martin Products	38048	2
15 (NS)	Manual, Operator's	M3699	1

NS=Not Shown

Figure 6. Martin® DT2H Reversing Cleaner XHD Cartridge, P/N DT2HC-XXXXXXXXXX

Table V. Martin® DT2H Reversing Cleaner XHD Cartridge Part Numbers and Dimensions

Part No.	Dim A	Dim B	Dim C	Dim D
DT2HC-18A12XXXX	12.00 (305)	27.00 (686)	36.16 (918)	4.75 (121)
DT2HC-18A18XXXX	18.00 (457)	27.00 (686)	36.16 (918)	1.75 (44)
DT2HC-24A18XXXX	18.00 (457)	33.00 (838)	42.16 (1071)	4.75 (121)
DT2HC-24A24XXXX	24.00 (610)	33.00 (838)	42.16 (1071)	1.75 (44)
DT2HC-30A24XXXX	24.00 (610)	39.00 (991)	48.16 (1223)	4.75 (121)
DT2HC-30A30XXXX	30.00 (762)	39.00 (991)	48.16 (1223)	1.75 (44)
DT2HC-36A30XXXX	30.00 (762)	45.00 (1143)	54.16 (1376)	4.75 (121)
DT2HC-36A36XXXX	36.00 (914)	45.00 (1143)	54.16 (1376)	1.75 (44)
DT2HC-42A36XXXX	36.00 (914)	51.00 (1295)	60.16 (1528)	4.75 (121)
DT2HC-42A42XXXX	42.00 (1067)	51.00 (1295)	60.16 (1528)	1.75 (44)
DT2HC-48A42XXXX	42.00 (1067)	57.00 (1448)	66.16 (1680)	4.75 (121)
DT2HC-48A48XXXX	48.00 (1219)	57.00 (1448)	66.16 (1680)	1.75 (44)
DT2HC-54A48XXXX	48.00 (1219)	63.00 (1600)	72.16 (1833)	4.75 (121)
DT2HC-54A54XXXX	54.00 (1372)	63.00 (1600)	72.16 (1833)	1.75 (44)
DT2HC-60A54XXXX	54.00 (1372)	69.00 (1753)	78.16 (1985)	4.75 (121)
DT2HC-60A60XXXX	60.00 (1524)	69.00 (1753)	78.16 (1985)	1.75 (44)
DT2HC-66A60XXXX	60.00 (1524)	75.00 (1905)	84.16 (2138)	4.75 (121)
DT2HC-66A66XXXX	66.00 (1676)	75.00 (1905)	84.16 (2138)	1.75 (44)
DT2HC-72A66XXXX	66.00 (1676)	81.00 (2057)	90.16 (2290)	4.75 (121)
DT2HC-84A78XXXX	78.00 (1981)	93.00 (2362)	102.16 (2595)	4.75 (121)
DT2HC-96A90XXXX	90.00 (2286)	105.00 (2667)	114.16 (2900)	4.75 (121)

Table V. (continued)

Part No.	Part No. Item 1	Part No. Item 2	Qty. Items 3 and 4	Qty. Item 6	Weight w/o Tens. (lbs)
DT2HC-18A12XXXX	37801-18	37803-18	4	2	56.6
DT2HC-18A18XXXX	37801-18	37803-18	4	15	138.6
DT2HC-24A18XXXX	37801-24	37803-24	6	3	63.6
DT2HC-24A24XXXX	37801-24	37803-24	6	3	145.5
DT2HC-30A24XXXX	37801-30	37803-30	6	4	70.4
DT2HC-30A30XXXX	37801-30	37803-30	6	4	152.1
DT2HC-36A30XXXX	37801-36	37803-36	8	5	77.4
DT2HC-36A36XXXX	37801-36	37803-36	8	5	159.1
DT2HC-42A36XXXX	37801-42	37803-42	8	6	83.9
DT2HC-42A42XXXX	37801-42	37803-42	8	6	165.9
DT2HC-48A42XXXX	37801-48	37803-48	10	7	90.9
DT2HC-48A48XXXX	37801-48	37803-48	10	7	172.9
DT2HC-54A48XXXX	37801-54	37803-54	10	8	97.7
DT2HC-54A54XXXX	37801-54	37803-54	10	8	179.4
DT2HC-60A54XXXX	37801-60	37803-60	10	9	104.7
DT2HC-60A60XXXX	37801-60	37803-60	10	9	206.7
DT2HC-66A60XXXX	37801-66	37803-66	12	10	111.2
DT2HC-66A66XXXX	37801-66	37803-66	12	10	234.0
DT2HC-72A66XXXX	37801-72	37803-72	12	11	118.2
DT2HC-84A78XXXX	37801-84	37803-84	14	12	125.0
DT2HC-96A90XXXX	37801-96	37803-96	16	13	132.0

Blade Description	Blade Part No.	Part No. Item 7
Tall Tungsten Carbide	DT2H-XXAXXXXXXX	39539-T
Tall Tungsten Carbide with SS Upright	DT2H-XXCXXXXXX	39539-TSS
Tungsten Carbide with SS Upright	DT2H-XXRXXXXXX	32494-TSS
Tungsten Carbide	DT2H-XXTXXXXXX	32494-T
Urethane	DT2H-XXUXXXXXX	32494-06U

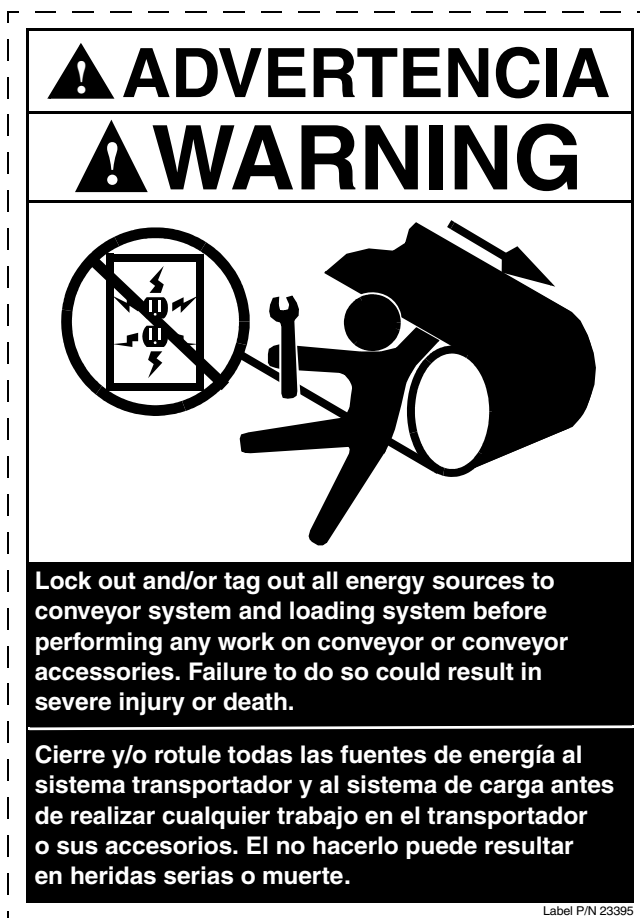

Figure 7. Conveyor Products Warning Label, P/N 23395



Figure 8. Pinch Point Warning Label, P/N 30528

Any product, process, or technology described here may be the subject of intellectual property rights reserved by Martin Engineering Company. Trademarks or service marks designated with the ® symbol are registered with the U.S. Patent and Trademark Office and may be proprietary in one or more countries or regions. Other trademarks and service marks belonging to Martin Engineering Company in the United States and/or other countries or regions may be designated with the “TM” and “SM” symbols. Brands, trademarks, and names of other parties, who may or may not be affiliated with, connected to, or endorsed by Martin Engineering Company, are identified wherever possible. Additional information regarding Martin Engineering Company’s intellectual property can be obtained at www.martin-eng.com/trademarks.

Problem Solved™ GUARANTEED!

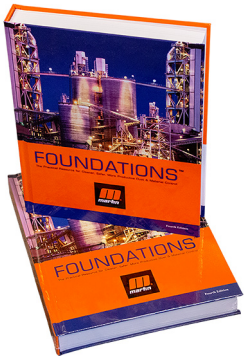

For nearly 30 years, Martin Engineering's Foundations™ Books have taught industry personnel to operate and maintain clean and safe belt conveyors. The Foundations™ Book, fourth edition, focuses on improving belt conveyors by controlling fugitive material. "The Practical Resource for Total Dust and Material Control," is a 576-page hard cover volume that provides information of value to industries where the efficient handling of bulk materials is a key to productivity and profitability.

Expanding upon the book, our Foundations™ Training Program addresses the design and development of more productive belt conveyors, and is offered in three customizable seminars. Attendees gain a better understanding of conveyor safety and performance, helping to justify upgrade investments and increase profitability.



Martin Engineering Australia Pty Ltd.
102 Christensen Road South
Stapylton QLD 4207 - Australia
+61 1300 627 364
salesau@martin-eng.com | www.martin-eng.com.au

