

***martin***®

***CleanScrape***®  
***Small Cleaner***

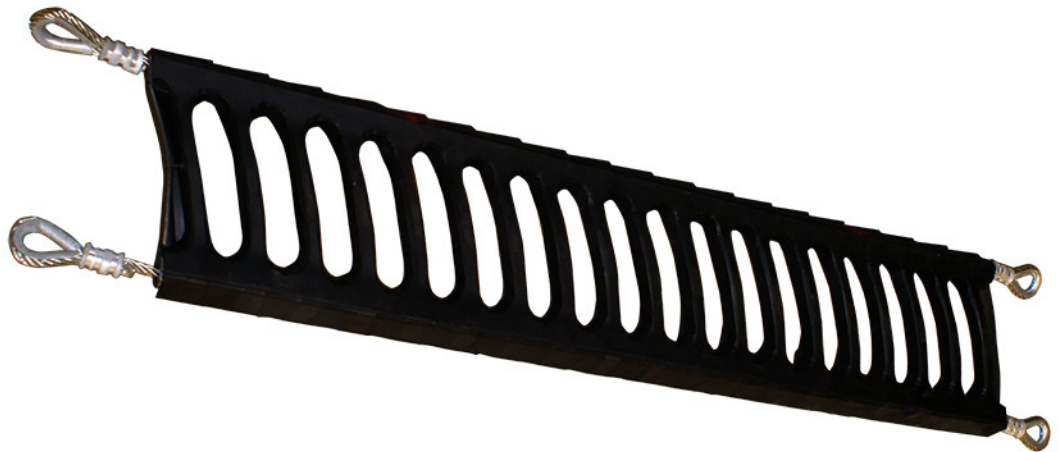

***Operator's Manual***  
***M4082***

# Important

MARTIN ENGINEERING HEREBY DISCLAIMS ANY LIABILITY FOR: DAMAGE DUE TO CONTAMINATION OF THE MATERIAL; USER'S FAILURE TO INSPECT, MAINTAIN AND TAKE REASONABLE CARE OF THE EQUIPMENT; INJURIES OR DAMAGE RESULTING FROM USE OR APPLICATION OF THIS PRODUCT CONTRARY TO INSTRUCTIONS AND SPECIFICATIONS CONTAINED HEREIN. MARTIN ENGINEERING'S LIABILITY SHALL BE LIMITED TO REPAIR OR REPLACEMENT OF EQUIPMENT SHOWN TO BE DEFECTIVE.

Observe all safety rules given herein along with owner and Government standards and regulations. Know and understand lockout/tagout procedures as defined by American National Standards Institute (ANSI) z244.1-1982, *American National Standard for Personnel Protection - Lockout/Tagout of Energy Sources - Minimum Safety Requirements* and Occupational Safety and Health Administration (OSHA) Federal Register, Part IV, 29 CFR Part 1910, *Control of Hazardous Energy Source (Lockout/Tagout); Final Rule*.

The following symbols may be used in this manual:



**Danger:** Immediate hazards that will result in severe personal injury or death.



**Warning:** Hazards or unsafe practices that could result in personal injury.



**Caution:** Hazards or unsafe practices that could result in product or property damages.



**Important:** Instructions that must be followed to ensure proper installation/operation of equipment.



**Note:** General statements to assist the reader.

# Table of Contents

---

<b>Section</b>	<b>Page</b>
List of Figures . . . . .	ii
List of Tables . . . . .	ii
Introduction . . . . .	1
General . . . . .	1
Installations without chutework . . . . .	1
Belt cleaner inspection access . . . . .	1
References . . . . .	1
Materials required . . . . .	1
Safety . . . . .	3
Before Installing Belt Cleaner . . . . .	4
Installing Belt Cleaner and Tensioners . . . . .	9
Locating belt cleaner . . . . .	9
Installing tensioner mount plate . . . . .	11
Installing tensioner on outside chute wall . . . . .	13
Installing tensioner on inside chute wall . . . . .	17
Tensioning cleaner . . . . .	18
After Installing Belt Cleaner . . . . .	19
Weekly Maintenance . . . . .	20
Replacing Breakaway Link . . . . .	21
Troubleshooting . . . . .	22
Part Numbers . . . . .	24
Appendix . . . . .	A-1

## List of Figures

---

<b>Figure</b>	<b>Title</b>	<b>Page</b>
1	Belt Cleaner Mounting Orientation . . . . .	5
2	Typical Belt Cleaner Mounting Positions . . . . .	6
3	Low Product Flow Belt Cleaner Mounting Positions . . . . .	7
4	Installations with Wide Chute Walls . . . . .	8
5	Belt Cleaner Location and Chute Wall Cutouts. . . . .	9
6	Installing Fixed Point Bracket . . . . .	10
7	Tensioner Mount Plates . . . . .	11
8	Tensioner Mount Plate Verification . . . . .	12
9	Installing Tensioner on Outside Chute Wall . . . . .	13
10	Installing Tensioner on Inside Chute Wall. . . . .	15
11	Installing Multi-Functional Tensioner on Inside Chute Wall . . . . .	16
12	Measure Cleaner Angle . . . . .	17
13	Replacing Breakaway Link . . . . .	21
14	CleanScrape <sup>®</sup> Small Cleaner, P/N C1CSXRXXXXXX . . . . .	25
15	Martin <sup>®</sup> Conveyor Products Warning Label, P/N 23395 . . . . .	26

## List of Tables

---

<b>Table</b>	<b>Title</b>	<b>Page</b>
I	CleanScrape <sup>®</sup> Conveyor Requirements . . . . .	2
II	CleanScrape <sup>®</sup> Small Cleaner Tensioning Chart. . . . .	18
III	Part Numbers for CleanScrape <sup>®</sup> Small Cleaner, P/N C1CSXRXXXXXX . . . . .	25

## **General**

CleanScape® is a Pre-Cleaner which is installed diagonally across the discharge pulley and forms a three dimensional curve. The cleaner has a matrix of tungsten carbide scrapers incorporated into the main rubber body during the vulcanization process. It is tensioned against the belt at an extremely low contact pressure. On a dual-cleaner system, a Secondary Cleaner is installed immediately following the Pre-Cleaner to remove stubborn material left on the conveyor belt. If a Pre-Cleaner cannot be used because of space limitations, Secondary Cleaners can be installed alone. Multiple Pre-Cleaners and/or Secondary Cleaners may be required to clean the belt. If the material-handling process or product could be affected by contamination from the use of these belt cleaners, the user is responsible for taking the necessary steps to prevent contamination. Consult Martin Engineering or a representative for alternate belt cleaners or belt cleaner locations to use where contamination may be an issue.

## **Installations without chutework**

These procedures were written for equipment that is being installed on enclosed pulley chutework. If the pulley is not enclosed, the equipment should be installed using the best available field resources and methods to ensure that the critical dimensions are followed for proper installation.

## **Belt cleaner inspection access**

If the belt cleaner is installed on enclosed pulley chutework, at least one Martin® Inspection Door should be installed. Martin® Inspection Doors are available from Martin Engineering or a representative.

## **References**

The following documents are referenced in this manual:

- American National Standards Institute (ANSI) z244.1-1982, *American National Standard for Personnel Protection - Lockout/Tagout of Energy Sources - Minimum Safety Requirements*, American National Standards Institute, Inc., 1430 Broadway, New York, NY 10018.
- Federal Register, Volume 54, Number 169, Part IV, 29 CFR Part 1910, *Control of Hazardous Energy Source (Lockout/Tagout); Final Rule*, Department of Labor, Occupational Safety and Health Administration (OSHA), 32nd Floor, Room 3244, 230 South Dearborn Street, Chicago, IL 60604.
- *Martin® Inspection Door Operator's Manual*, P/N M3891

## **Materials required**

Installation of this equipment requires the use of standard hand tools, grinder, welder, and cutting torch.

**NOTE**

Prior to installation verify belt width to head pulley size ratio is not greater than 3:1 and that application matches belt conditions listed in table.

**Table I. CleanScape® Conveyor Requirements**

Cleaner Type	Head Pulley Diameter		Belt Width	Maximum Belt Speed	
	Min.	Max.		Vulcanized Splice	Mechanical Splice
<b>Small</b>	300 mm (12 in.)	550 mm (22 in.)	400–1000 mm (18–48 in.)	6 m/s (1200 Ft/Min)	4m/s (800 Ft/Min)

## Safety

All safety rules defined in the above documents and all owner/employer safety rules must be strictly followed when working on the belt cleaner.



### **⚠ DANGER**

Do not touch or go near the conveyor belt or conveyor accessories when the belt is running. Your body or clothing can get caught and you can be pulled into the conveyor, resulting in severe injury or death.



### **⚠ DANGER**

Before installing, servicing, or adjusting the belt cleaner, turn off and lockout / tagout / blockout / testout all energy sources to the conveyor and conveyor accessories according to ANSI standards. Failure to do so could result in serious injury or death.

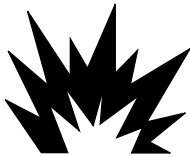

### **⚠ DANGER**

If this equipment will be installed in an enclosed area, test the gas level or dust content before using a cutting torch or welding. Using a torch or welding in an area with gas or dust may cause an explosion resulting in serious injury or death. Follow local confined space procedures.



### **⚠ WARNING**

Before using a cutting torch or welding the chute wall, cover the conveyor belt with a fire retardant cover. Failure to do so can allow the belt to catch fire. Follow local fire watch procedures.

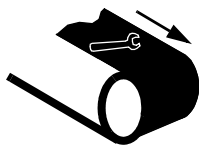

### **⚠ WARNING**

Remove all tools from the installation area and conveyor belt before turning on the conveyor. Failure to do so can cause serious injury to personnel or damage to the belt and conveyor.



### **⚠ WARNING**

Cleaner can be heavy and may require two people to lift. Attempting to lift the belt cleaner without assistance could result in injury.

# Before Installing Belt Cleaner

## IMPORTANT

The delivery service is responsible for damage occurring in transit. Martin Engineering CANNOT enter claims for damages. Contact your transportation agent for more information.

1. Inspect shipping container for damage. Report damage to delivery service immediately and fill out delivery service's claim form. Keep any damaged goods subject to examination.
2. Remove belt cleaner assembly from shipping container.
3. If anything is missing contact Martin Engineering or a representative.



## ⚠ DANGER

Before installing, servicing, or adjusting the belt cleaner, turn off and lockout / tagout / blockout / testout all energy sources to the conveyor and conveyor accessories according to ANSI standards. Failure to do so could result in serious injury or death.

4. Turn off and lockout / tagout / blockout / testout energy source according to ANSI standards (see "References").

## ⚠ DANGER

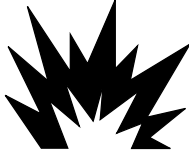

If this equipment will be installed in an enclosed area, test the gas level or dust content before using a cutting torch or welding. Using a torch or welding in an area with gas or dust may cause an explosion resulting in serious injury or death. Follow local confined space procedures.

5. If using a cutting torch or welding, test atmosphere for gas level or dust content. Cover conveyor belt with fire retardant cover.

## ⚠ CAUTION

Ensure conveyor chute remains unplugged. A plugged conveyor chute may cause cleaner to damage belt.

## NOTE

The chute wall that the tensioner will be located on is referred to as the "operator side." The other side of the chute is referred to as the "far side."

## NOTE

The installation instructions in this manual are the preferred methods for the most common installations. Contact Martin Engineering for alternative installation options.





**Correct Mounting Position**



**Incorrect Mounting Position**

**Figure 1. Belt Cleaner Mounting Orientation**

**IMPORTANT**

**The CleanScrape<sup>®</sup> carbide scrapers are molded into the rubber body of the cleaner at a slight angle creating a serrated cleaning edge. For effective cleaning, the cleaner can only be mounted in orientation shown.**

6. Inspect belt cleaner mounting area for possible obstructions that could interfere with proper mounting. Refer to following guidelines:
  - a. Ensure cleaner does not lie in path of material unloading from conveyor belt.
  - b. The top side of cleaner should be no less than the 2 o'clock position. Material could strike the back of the cleaner causing wear which will lead to premature failure.
  - c. The ideal installation angle is 17°–18°. Installation angles of 15°–21° are acceptable. Higher angles are normally utilized in cleaning material that tends to adhere to the belt, these higher angles lead to increased wear on the blade.
  - d. Belt width must not exceed a ratio of 3:1 to the head pulley diameter. For example, the maximum belt width for a conveyor with a 550 mm (22 in.) head pulley is 1000 mm (40 in.).
  - e. Chute walls must be strong enough to not flex as tension is applied to cleaner. If chute wall flexes inadequate tension may be applied to cleaner resulting in poor cleaning performance. Additional chute wall structure support may be added to prevent chute wall from flexing.
  - f. The distance between the cleaner and the chute wall should be minimized. Martin Engineering recommends keeping the distance to 150mm (6 in.) maximum per side (see Figure 4). Excess chain or cable could result in vibration that could damage the belt or the cleaner. If necessary, build a sub-wall to support the tensioners in the proper position. Consult Martin Engineering for installation assistance if parameters fall outside of this range.

- g. For typical installations, start with the bottom rope in the 6 o'clock position and the top rope in the 3 o'clock position. The exact positioning of the top rope is a result of the installation angle.
  - h. For belts with low product flow, lower the top rope until cleaner is out of material path. Cleaner angle must be 15° or greater.
7. Lack of service can contribute to poor belt cleaning performance. Follow local guidelines for access:
- (1) Clearance for service outside the chute must be at least equal to the belt width.
  - (2) Cleaners must have service platforms. Cleaners should be mounted at least 600 mm (24 in.) above the work platform.
  - (3) If the belt width is 1400 mm (54 in.) or larger consider access doors on both sides of the chute.

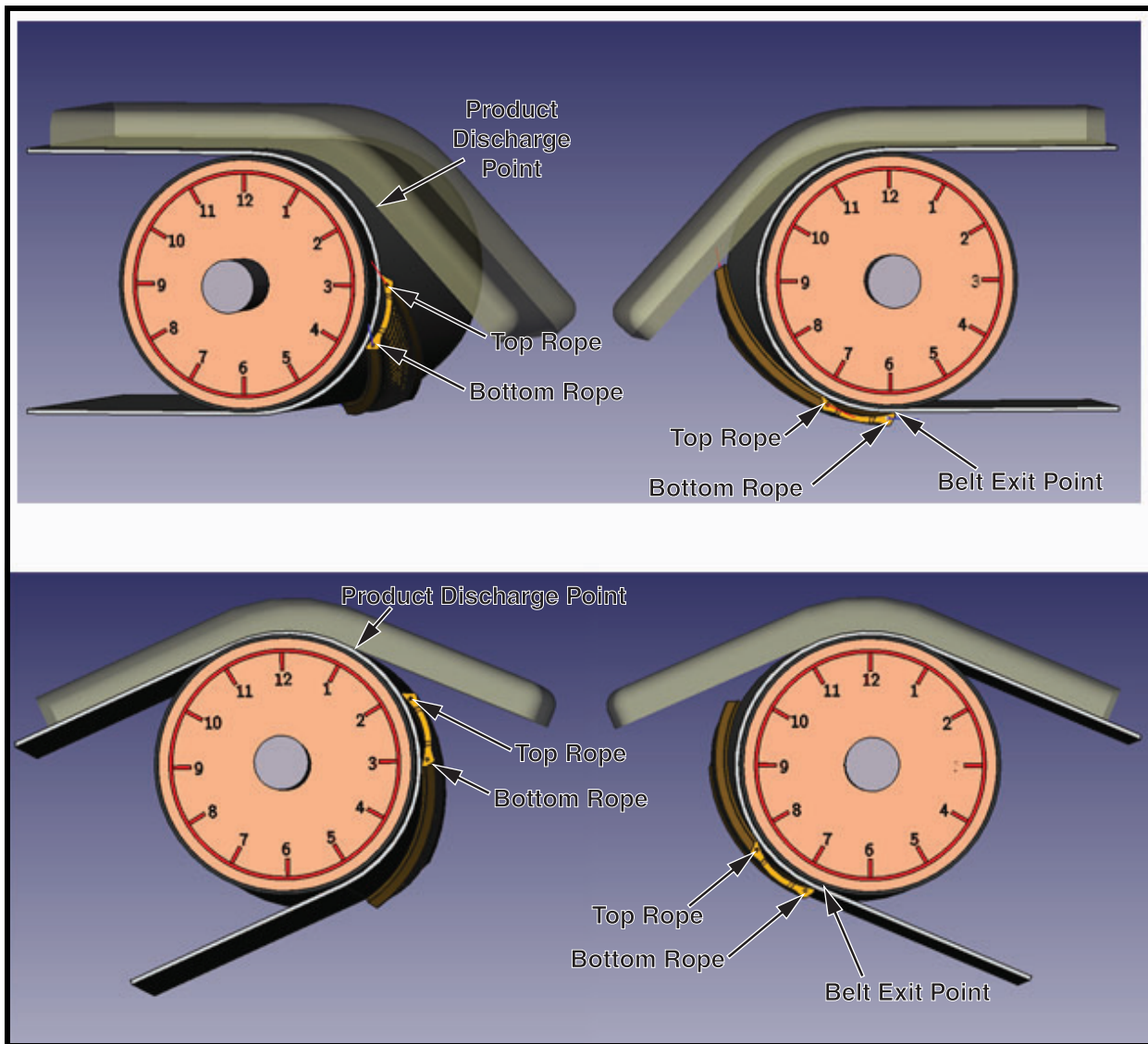

**Figure 2. Typical Belt Cleaner Mounting Positions**

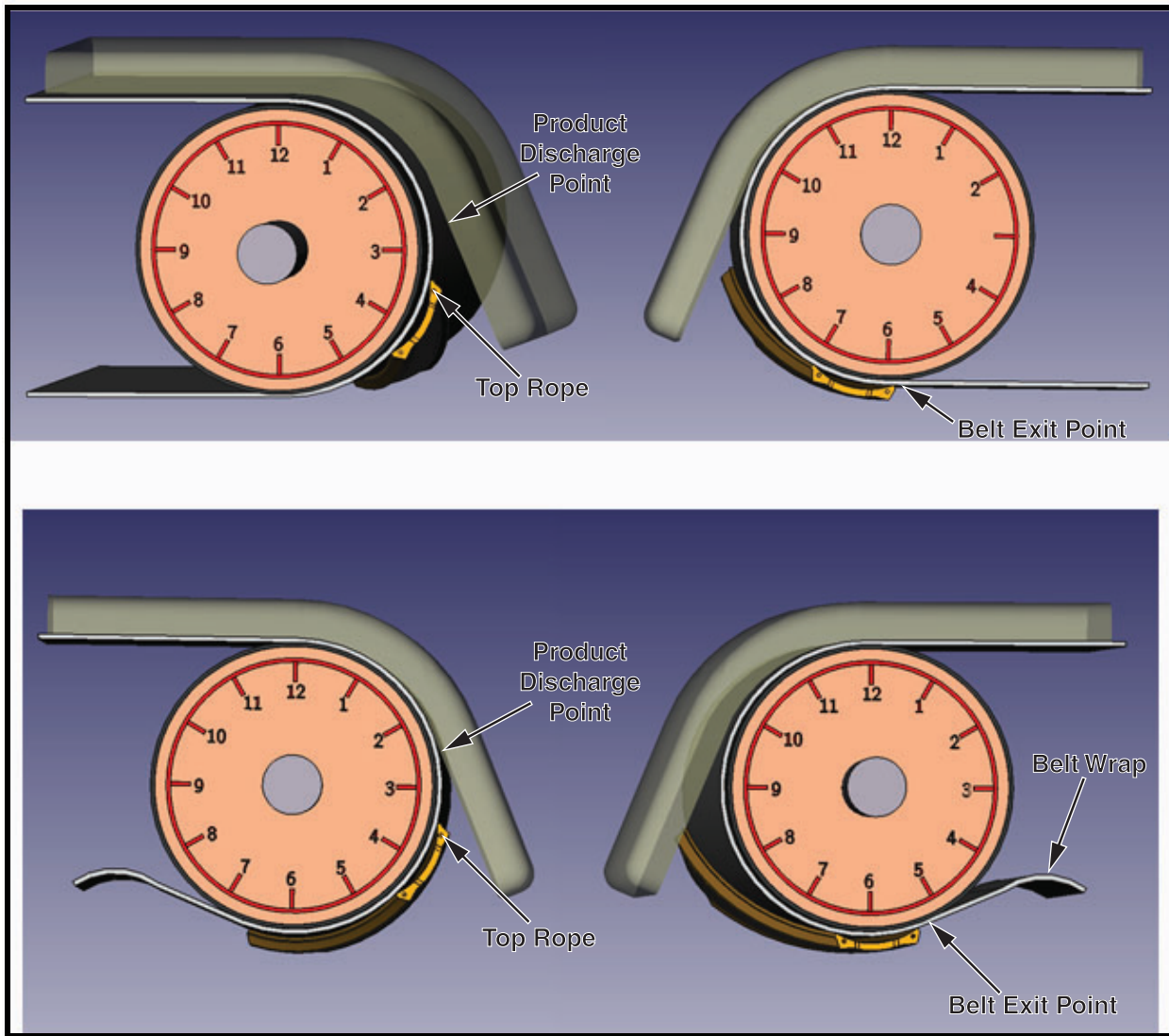
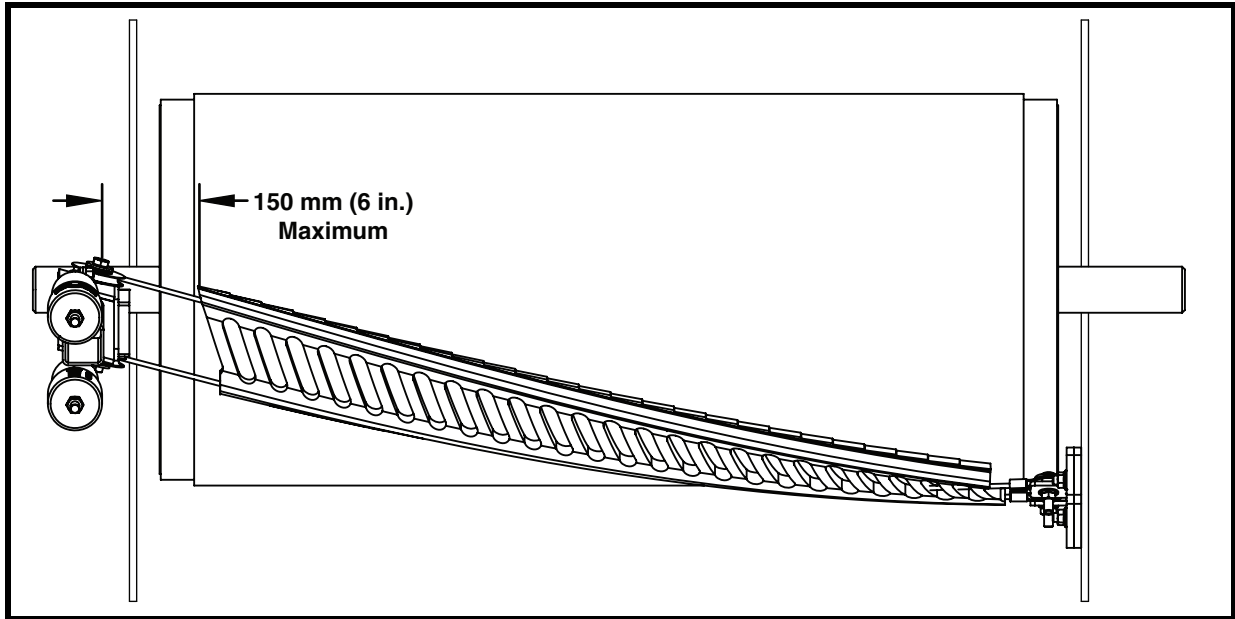

Figure 3. Low Product Flow Belt Cleaner Mounting Positions

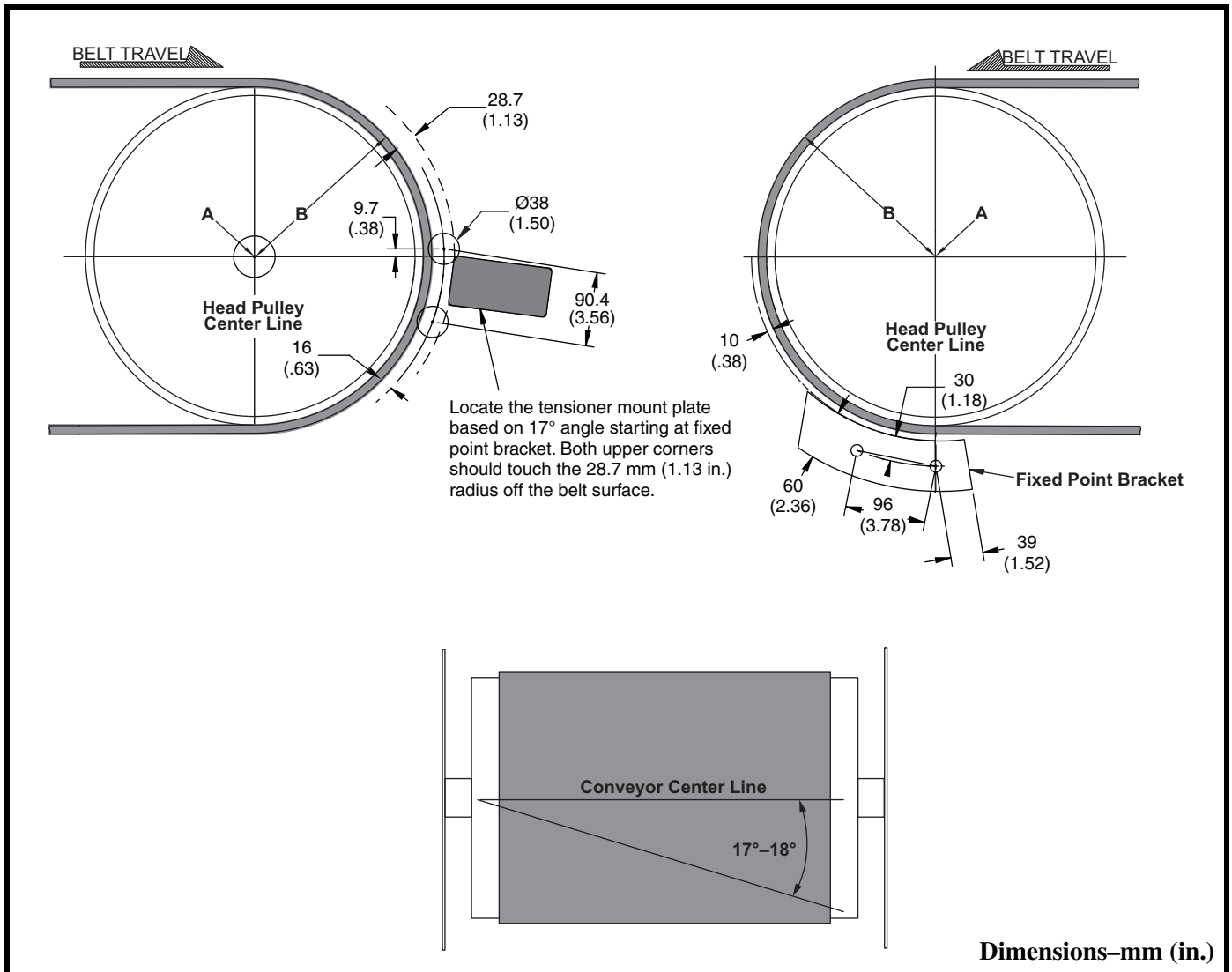

**Figure 4. Installations with Wide Chute Walls**

**IMPORTANT**

The maximum distance between chute wall and center of wheel is 150 mm (6 in.). Excess free chain or cable causes too much vibration resulting in damage to cleaner and components. If necessary, build a sub wall to support the tensioners.

# Installing Belt Cleaner & Tensioners

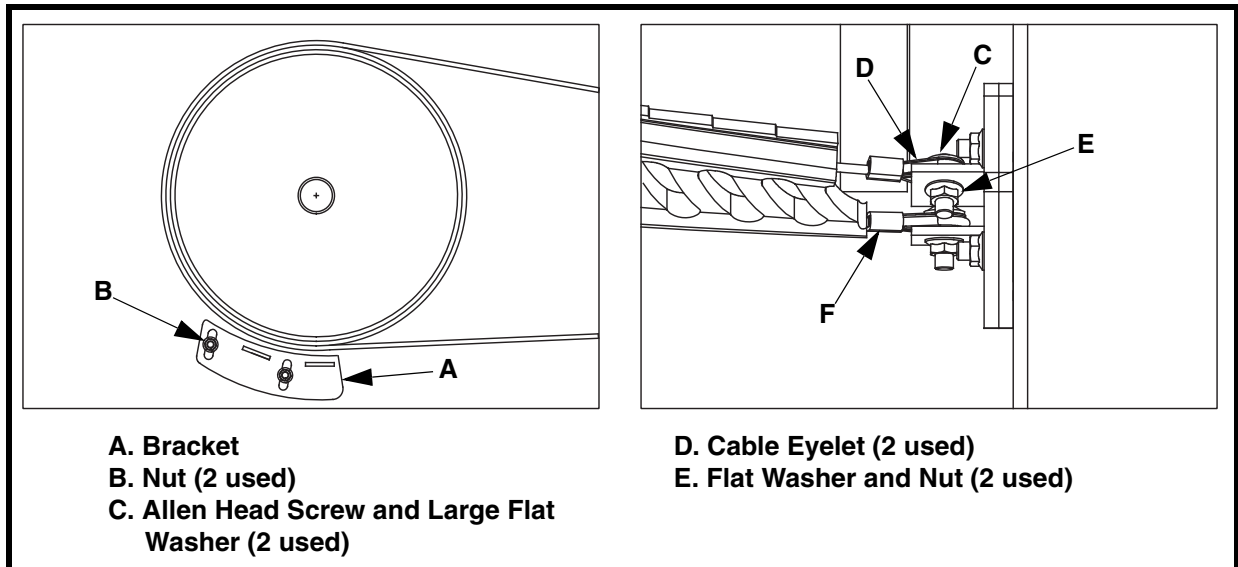

**Figure 5. Belt Cleaner Location & Chute Wall Cutouts**

## ***Locating belt cleaner***

1. On both sides of chute, find pulley center point (A).
2. Measure radius of head pulley including lagging and belt thickness (B).
3. On the far side of chute, start from center point (A), measure the total distance calculated in step 2 (B + 10 mm [3/8 in.]), and draw an arc on chute wall.
4. On the operator side of chute, start from center point (A), draw an arc on chute wall with a radius of (B + 16 mm [5/8 in.]). Draw an additional arc on chute wall with a radius of (B + 28.7 mm [1-1/8 in.]).
5. On the far side of chute:
  - a. If bolting fixed point bracket to chute wall, do the following:
    - (1) Position fixed point bracket on far side chute wall as shown in Figure 5. Align bolt hole on bracket with head pulley center line.

- (2) Mark bracket hole locations.
  - (3) Drill or cut two 12.7 mm (1/2-in.) holes for screws in far side chute wall.
  - (4) Mount fixed point bracket to inside of far side chute wall using countersunk screws and nuts.
- b. If welding fixed point bracket to chute wall, do the following:
- (1) Position fixed point bracket on far side chute wall as shown in Figure 5. Align bolt hole on bracket with head pulley center line.
  - (2) Weld bracket to chute wall. Weld completely around bracket. Do not skip weld.



**Figure 6. Installing Fixed Point Bracket**

- c. Install bracket (A) using nuts (B). Hand tighten nuts.
- d. Attach cleaner to far side bracket by inserting hex head screw and large flat washer (C) through cable eyelet (D) and fastening with flat washer and nut (E). Hand tighten nuts.



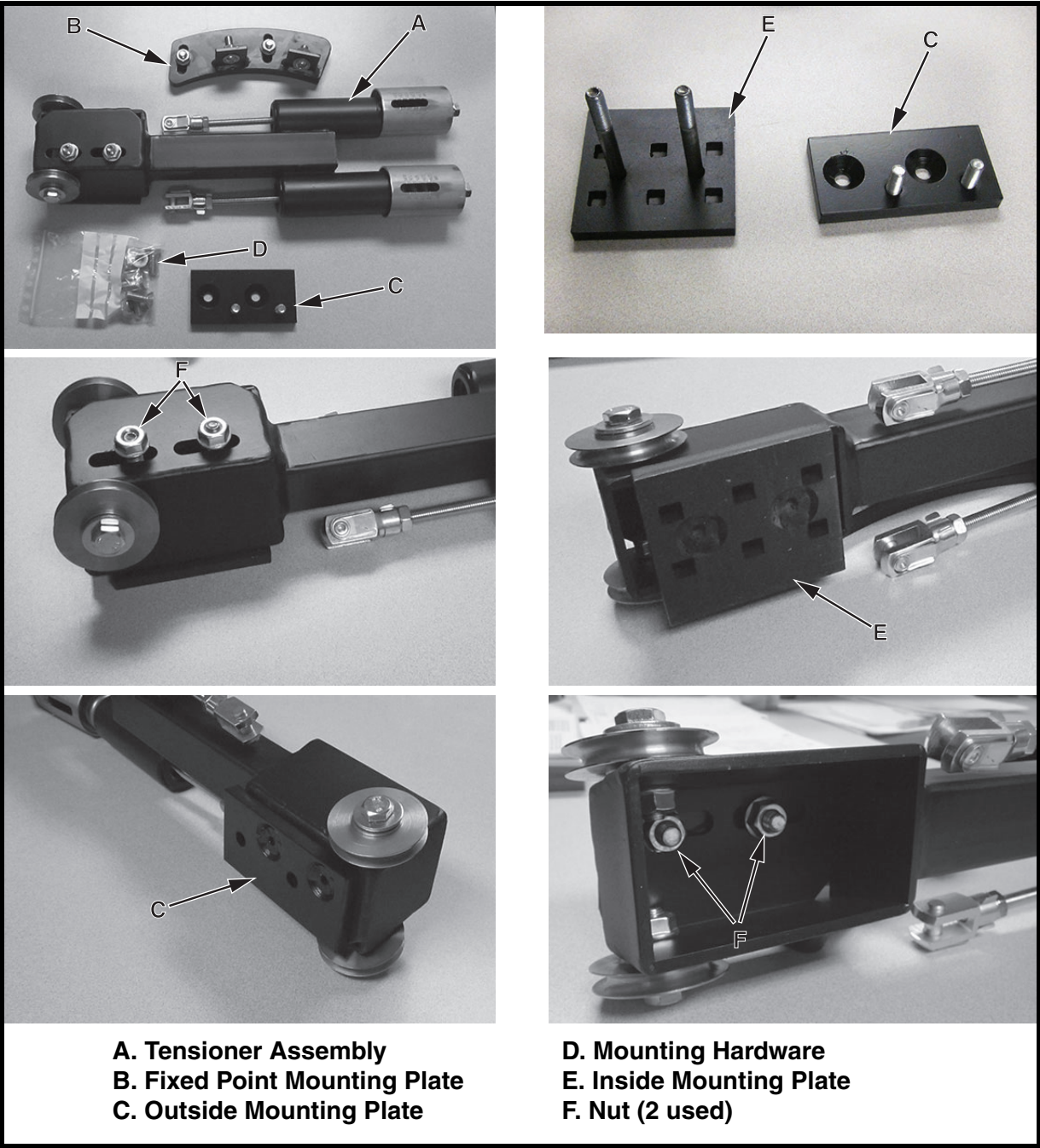

Figure 7. Tensioner Mount Plates

*Installing tensioner mount plate*

**IMPORTANT**

Tensioners used with CleanScrape® Small Cleaners can be installed on either the inside or the outside of the chute wall. Tensioners are shipped with the inside mounting plate (E) installed. If the application requires tensioners to be mounted on the outside of the chute wall, the outside mounting plate (C) must be used.

1. Determine if tensioner will be mounted on the inside or outside of chute wall.
2. If the tensioner will be installed on the outside of chute wall, the tensioner mount plate must be changed as follows:
  - a. Remove nuts (F).
  - b. Remove inside mounting plate (E) from tensioner assembly (A).
  - c. Install outside mounting plate (C) on tensioner assembly.
  - d. Install and tighten nuts (F).

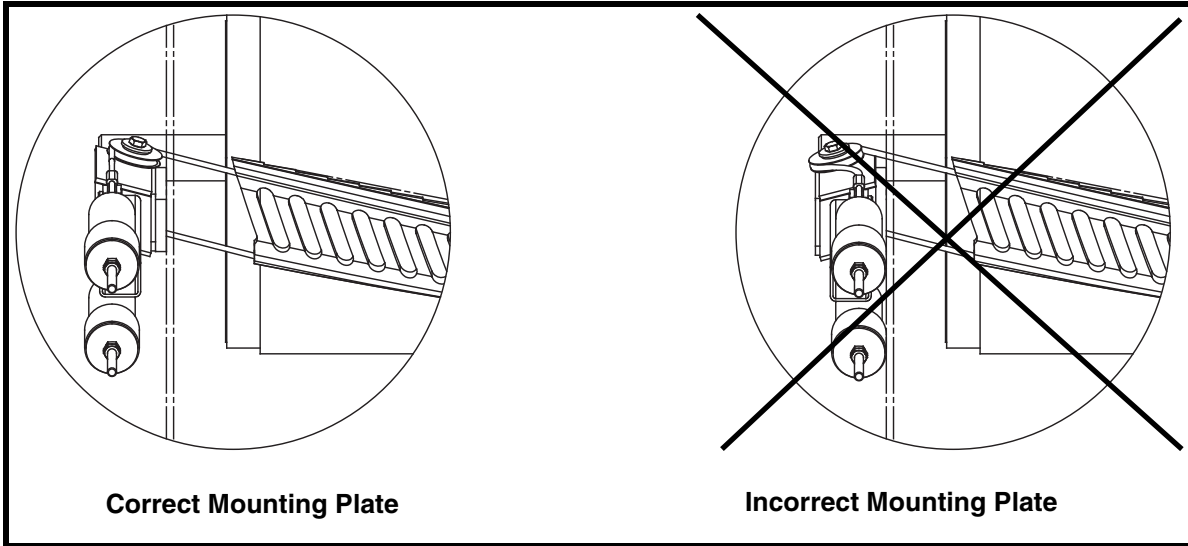
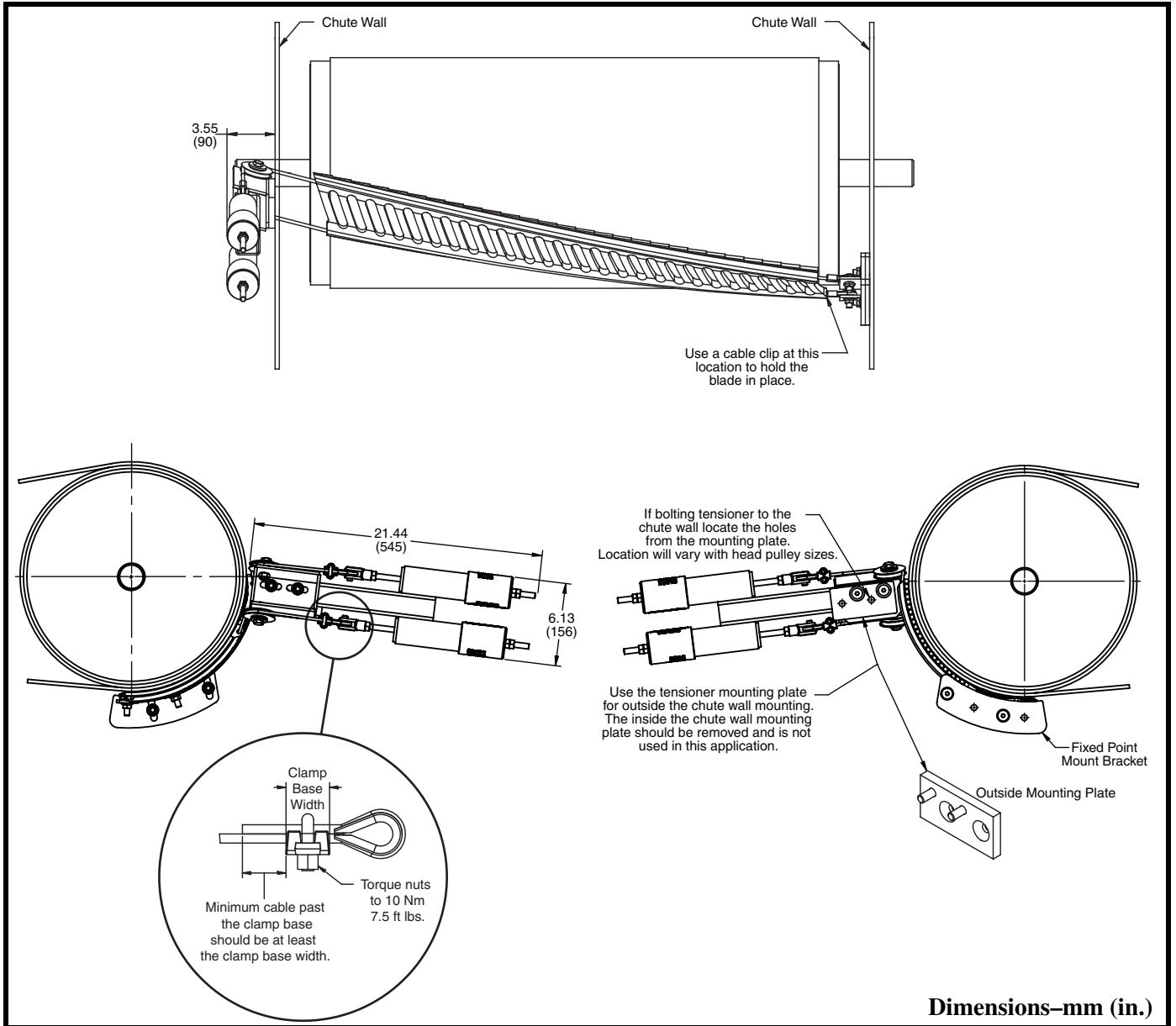

**Figure 8. Tensioner Mount Plate Verification**

**▲ CAUTION**

**The correct mounting plate must be used or damage to cleaner will result. Using the incorrect mounting plate results in cable being cut by roller and ultimately cleaner failure.**





**Figure 9. Installing Tensioner on Outside Chute Wall**

***Installing tensioner on outside chute wall***

1. For installations on the outside of the chute wall:
  - a. Mark chute wall cutouts as shown in Figure 5.
  - b. Cut holes in chute wall. Remove burrs and sharp edges.
  - c. Install outside mounting plate on tensioner. See Figure 7.
    - (1) Remove nuts (F).
    - (2) Remove inside mounting plate (E) from tensioner assembly (A).
    - (3) Install outside mounting plate (C) on tensioner assembly.
    - (4) Install and tighten nuts (F).

- d. Position tensioner in desired location free from obstructions as shown in Figure 9. Make sure cleaner cables will not rub on chute wall cutouts. Reposition tensioner or enlarge cutouts as required.
  - e. Mark location of tensioner mounting plate.
  - f. Remove mounting plate from tensioner.
  - g. Bolt or weld mounting plate in location marked in Step 1.e.
  - h. Install tensioner onto mount plate.
2. Measure approximate cable length required and cut cable.
  3. Assemble cable eyelet and clamp as shown in Figure 9.
  4. Torque nuts on clamp to 10 Nm (7.5 ft lbs).
  5. Attach each cable to tensioner.
  6. Tighten tensioner adjustment nuts until cleaner is held firmly to belt.
  7. Center cleaner on belt and install a cable clamp on the far side upper cleaner cable. This clamp keeps the cleaner centered on the belt.
  8. Adjust fixed point bracket and tensioner bracket, so outer two elements on each side are away from the belt. Increase the number of elements off the belt as necessary in order to ensure the mechanical splices will pass.
  9. Tighten all fasteners on fixed point brackets and tensioner mounts.
  10. Tension cleaner according instructions in *Tensioning cleaner*.

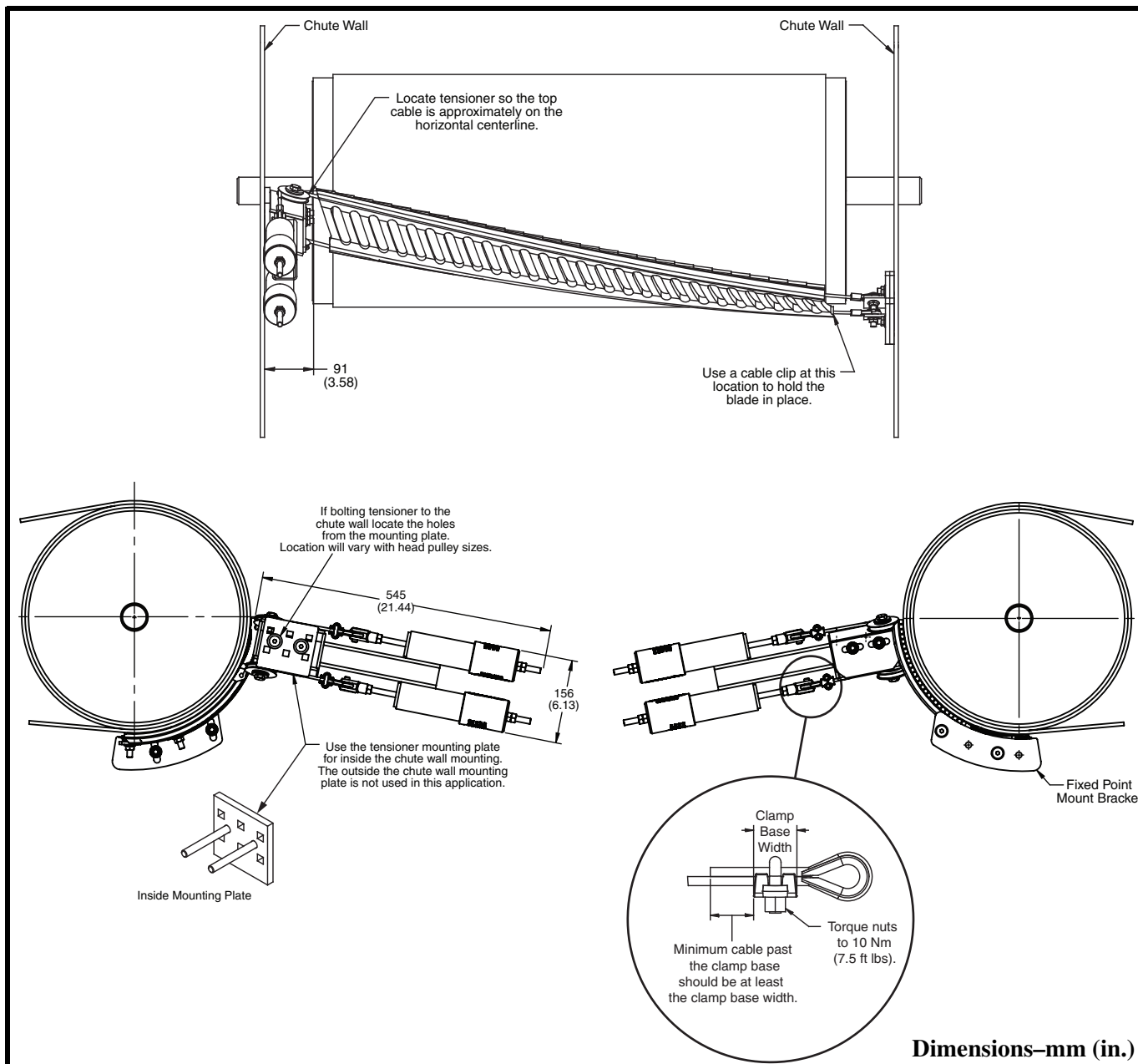

Figure 10. Installing Tensioner on Inside Chute Wall

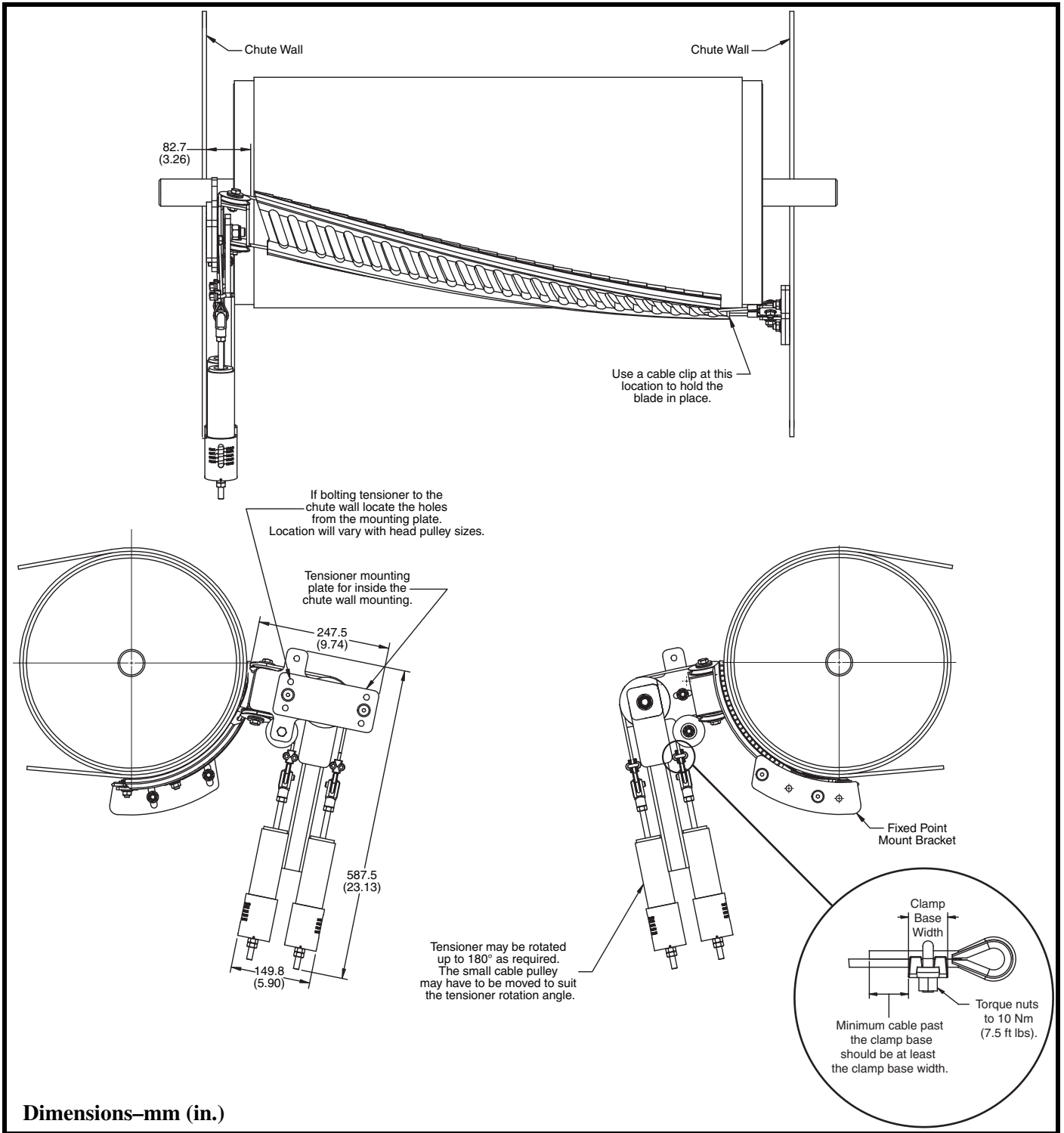
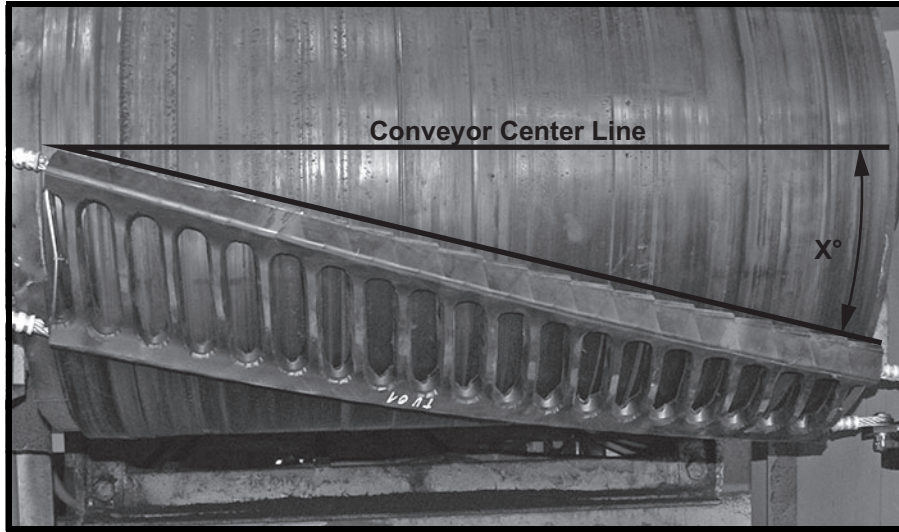

Figure 11. Installing Multi-Functional Tensioner on Inside Chute Wall

## ***Installing tensioner on inside chute wall***

1. For installations on the inside of the chute wall:
  - a. The top cleaner cable should be located at approximately this line when installation is complete.
  - b. The inside mounting plate is factory installed on the tensioner.
  - c. Position tensioner in desired location free from obstructions as shown in Figure 10 or 11.
  - d. Mark location of tensioner mounting plate.
  - e. Remove mounting plate from tensioner.
  - f. Bolt or weld mounting plate in location marked in Step 1.e.
  - g. Install tensioner onto mount plate.
2. Measure approximate cable length required and cut cable.
3. Assemble cable eyelet and clamp as shown in Figure 10 or 11.
4. Torque nuts on clamp to 10 Nm (7.5 ft lbs).
5. Attach each cable to tensioner.
6. Tighten tensioner adjustment nuts until cleaner is held firmly to belt.
7. Center cleaner on belt and install a cable clamp on the far side upper cleaner cable. This clamp keeps the cleaner centered on the belt.
8. Adjust fixed point bracket and tensioner bracket, so outer two elements on each side are away from the belt. Increase the number of elements off the belt as necessary in order to ensure the mechanical splices will pass.
9. Tighten all fasteners on fixed point brackets and tensioner mounts.
10. Tension cleaner according instructions in *Tensioning cleaner*.



**Figure 12. Measure Cleaner Angle**

***Tensioning cleaner***

1. Measure angle of cleaner.
2. Determine tension required according to tensioning chart.
3. Tighten tensioners. Install and tighten jam nut against tensioning nut on each tensioner.
4. Make sure outer two elements on each side are away from belt.

**Table II. CleanScrape® Small Cleaner Tensioning Chart**

CSP Size	Belt Width		Upper Rope Force Required	Lower Rope Force Required*
	mm	(in.)		
Small	500	18	1.00 kN	0.85 kN
	501–650	24	1.20 kN	1.00 kN
	651–800	30	1.40 kN	1.20 kN
	801–900	36	1.50 kN	1.30 kN
	901–1000	42	1.60 kN	1.40 kN

\*Lower rope should have 10% to 15% less force than upper rope.

# After Installing Belt Cleaner



1. Thoroughly wipe chute wall clean above tensioner.
2. Place Conveyor Products Warning Label (P/N 23395) on outside chute wall visible to belt cleaner operator.
3. Additional safety labels are available from CEMA. For more information regarding CEMA safety labels visit [www.cemanet.org](http://www.cemanet.org).

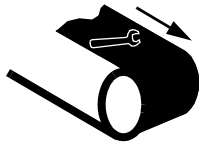

## **⚠ WARNING**

**Failure to remove tools from installation area and conveyor belt before turning on energy source can cause serious injury to personnel and damage to belt.**



## **⚠ DANGER**

**Do not touch or go near conveyor belt or conveyor accessories when conveyor belt is running. Body or clothing can get caught and pull body into conveyor belt, causing severe injury or death.**

4. Start conveyor belt. Observe belt cleaner operation for several revolutions of the belt. Properly shutdown belt and make appropriate adjustments. Return belt to service.
5. Run conveyor belt for one hour, adjust belt cleaner as necessary.



## **⚠ DANGER**

**Before installing, servicing, or adjusting the belt cleaner, turn off and lockout / tagout / blockout / testout all energy sources to the conveyor and conveyor accessories according to ANSI standards or country specific safety standards (DIN, ISO, etc.). Failure to do so could result in serious injury or death.**

- a. Make sure all fasteners are tight. Tighten if necessary.
- b. Inspect belt cleaner for the following:
  - (1) Wear. (A small amount of “break-in” wear may be found. This will stop once blades wear to conveyor belt contour.)
  - (2) Material buildup. (No material between blades and return side of conveyor belt should be found.)
- c. If wear, material buildup, or some other problem exists, see “Troubleshooting.”
- d. Monitor cleaner and after 7–10 days re-tension cleaner to overcome and thimble bedding in.

## Weekly Maintenance

---

### IMPORTANT

Read entire section before beginning work.

### NOTE

Maintenance inspection should be performed no less than weekly. Some applications may require more frequent maintenance inspections.



### ⚠ DANGER

Before installing, servicing, or adjusting the belt cleaner, turn off and lockout / tagout / blockout / testout all energy sources to the conveyor and conveyor accessories according to ANSI standards or country specific safety standards (DIN, ISO, etc.). Failure to do so could result in serious injury or death.

1. Remove any material from belt cleaner.
2. Make sure all fasteners are tight. Tighten if necessary.
3. Check tension on cleaner. Re-tension if necessary.
4. Wipe all labels clean. If labels are not readable, contact Martin Engineering or a representative for replacements.
5. Check blades for excessive wear. Replace blade if carbide metal wear is greater than 5 mm (3/16 in.).
6. Monitor cleaner and after 7-10 days re-tension cleaner to overcome any thimble bedding-in.
7. Remove equipment from service if there is any indication it is not functioning properly. Call Martin Engineering or a representative for assistance. Do NOT return equipment to operation until the cause of the problem has been identified and corrected.

### ⚠ WARNING

Failure to remove tools from maintenance area and conveyor belt before turning on energy source can cause serious injury to personnel and damage to belt.

8. Remove all tools from maintenance area.

### ⚠ DANGER

Do not touch or go near conveyor belt or conveyor accessories when conveyor belt is running. Body or clothing can get caught and pull body into conveyor belt, causing severe injury or death.

9. Start conveyor belt. Observe belt cleaner operation for several revolutions of the belt. Service or adjust belt cleaner as necessary to ensure proper belt cleaner operation.

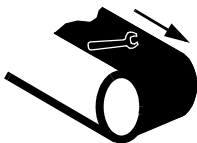



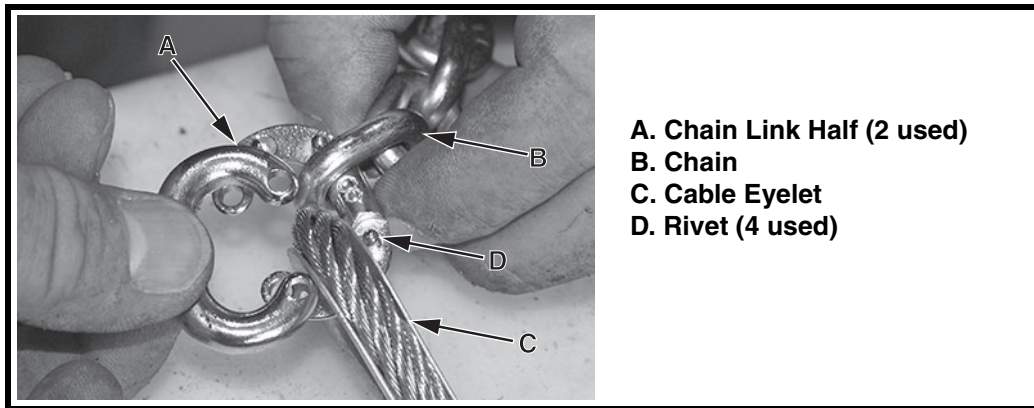

Figure 13. Replacing Breakaway Link

### NOTE

#### *Replacing Breakaway Link*

The CleanScrape<sup>®</sup> Cleaner is equipped with two breakaway links that are designed to let the operator side of the cleaner breakaway from the tensioners and fall away from the belt. The cleaner remains attached to the far side bracket to prevent damage to the cleaner or conveyor components.

1. If breakaway links break, install new links as follows:
  - a. Install one half of chain link (A) onto chain (B) and cable eyelet (C).
  - b. Install second half of chain link onto first half.
  - c. Place link on solid surface and peen rivets (D) to lock chain link halves together.

# Troubleshooting



**⚠ DANGER**

Before installing, servicing, or adjusting the belt cleaner, turn off and lockout / tagout / blockout / testout all energy sources to the conveyor and conveyor accessories according to ANSI standards or country specific safety standards (DIN, ISO, etc.). Failure to do so could result in serious injury or death.

Symptom	Corrective Action
Insufficient cleaning and carryback.	Check to see that cleaner is contacting the belt across the front edge of the cleaner. Recheck mounting dimensions and adjust as necessary. Gradually increase tension in 5-10% increments, maintaining 15% less tension on bottom rope, until cleaning is sufficient. Ensure tensioner spring is not totally collapsed and watch for chute flex.
Belt is cleaner on one side than the other.	Check installation, ensure cleaner is properly mounted and make any adjustments. Cleaner is likely out on one side and needs to be moved closer to the belt, re-tension cleaner (see Figure 9).
Blade dancing or vibration.	Check installation, ensure cleaner is properly mounted and make any adjustments. Cleaner is likely out on one side and needs to be moved closer to the belt, re-tension cleaner as described above (see Figure 9). Check tension on tensioner gauge to be sure of proper tension. Reset tension according to tensioning charts. Ensure blade is installed at proper angle. Ensure cleaner is centered on the belt and excess cable on either side of belt does not exceed 150 mm (6 in.).  Ensure chute wall is not flexing. Increase support as necessary.
Cleaner is catching on mechanical splice.	Check that outer 3–4 elements are off the belt by at least 3–6 mm (1/8–1/4 in.) to allow for the splice to flow through the cleaner without catching. Increase gap as necessary to allow splice to pass.
Material builds up in gaps.	Remove any excess material and check to ensure cleaner is properly located. Ensure bottom rope is properly positioned, adjust bottom rope on bottom side away from conveyor slightly by rotating bottom bracket. This will increase gap and allow material to be discharged more easily. Add more tension. Increase difference between tension on top and bottom rope to 15%.

**NOTE**

Conveyor equipment such as conveyor belt cleaners are subject to a wide variety of bulk materials characteristics and often have to perform under extreme operating or environmental conditions. It is not possible to predict all circumstances that may require troubleshooting. Contact Martin Engineering or a representative if you are experiencing problems other than those listed in the “Troubleshooting” chart above. Do not return the equipment to operation until the problem has been identified and corrected.

***Installation checklist***

If after taking the corrective actions suggested under “Troubleshooting” you are still experiencing problems, check for the following:

<b>Installation Checklist</b>
✓ Pre-Cleaner blade is proper distance from belt surface on both sides of head pulley.
✓ Pre-Cleaner blade tip does not lie in path of material flow.
✓ Blade is centered on belt.

# Part Numbers

This section provides product names and corresponding part numbers for CleanScrape® Cleaners and related equipment. Please reference part numbers when ordering parts:

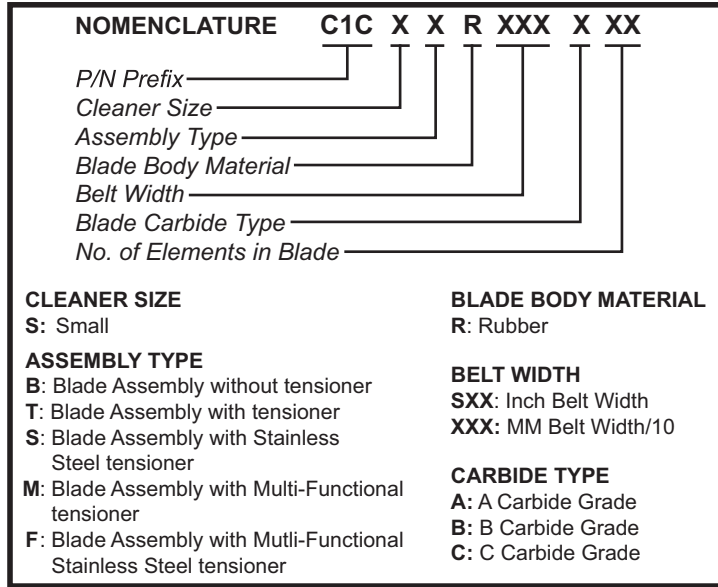

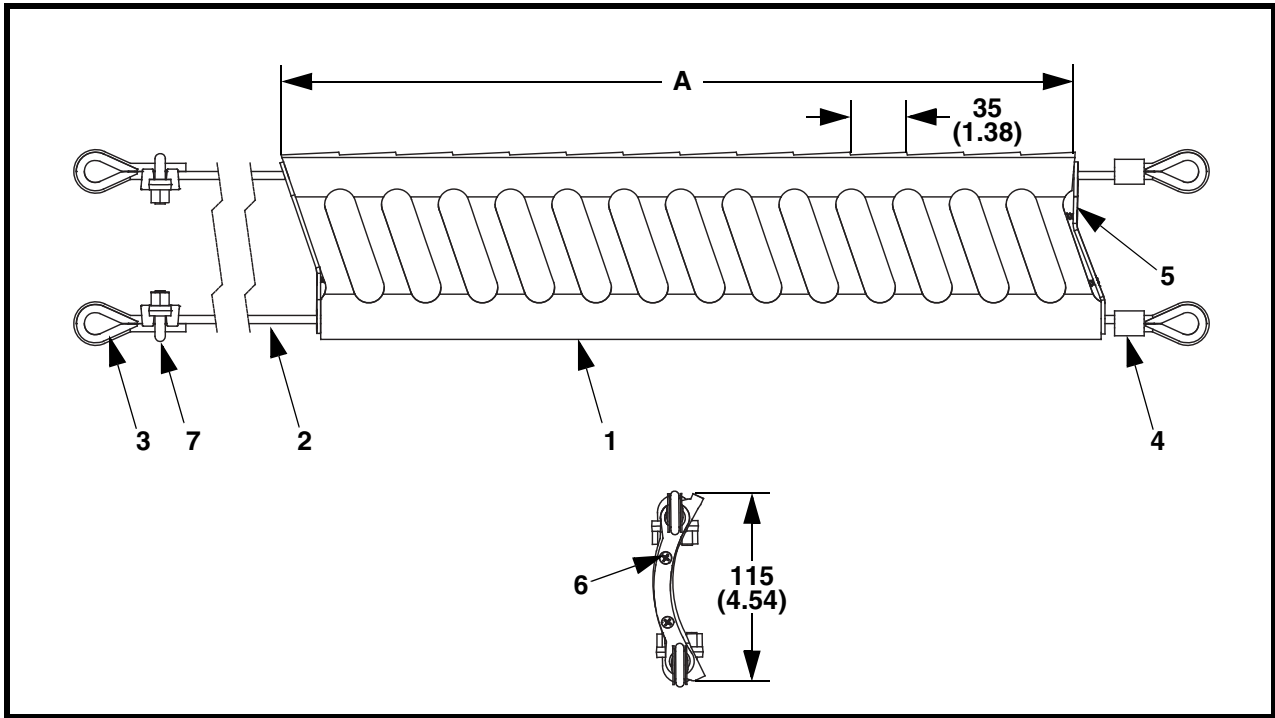

**Figure 14. CleanScape® Small Cleaner, P/N C1CSXRXXXXXX**

Item	Description	Part No.	Qty.
1	Blade 35mm LG Element	Table III	—
2	Wire Rope 5mm SS	C1CP51003S	—
3	Wire Rope Thimble for 5mm Cable	C1CP51005S	4
4	Swage Sleeve for 5mm Cable	C1CP51004C	2
5	End Safety Plate – Small	C1CP50001S	2
6	Screw Wood #6 x 3/4 316 SS	39367	4
7	Wire Rope Clip 3/16 Galv	32264-02	3
8 (NS)	Installation Kit	Table III	1
9 (NS)	Label Conveyor Products Warning	23395	2
10 (NS)	Operator's Manual	M4082	1
11 (NS)	CleanScape® Tag	39495	1
12 (NS)	Tie Nylon Cable	30916	1

NS = Not Shown

**Table III. Part Numbers for CleanScape® Small Cleaner, P/N C1CSXRXXXXXX**

Assembly Part No.	Part No. Item 1	Assembly Part No.	Part No. Item 3
C1CSXRXXXAXX	C1CBCSA	C1CSTRXXXXXX	C1CT1ST
C1CSXRXXXBXX	C1CBCSB	C1CSSRXXXXXX	C1CT1SS
C1CSXRXXXCXX	C1CBCSC	C1CSMRXXXXXX	C1CT2ST
		C1CSFRXXXXXX	C1CT2SS

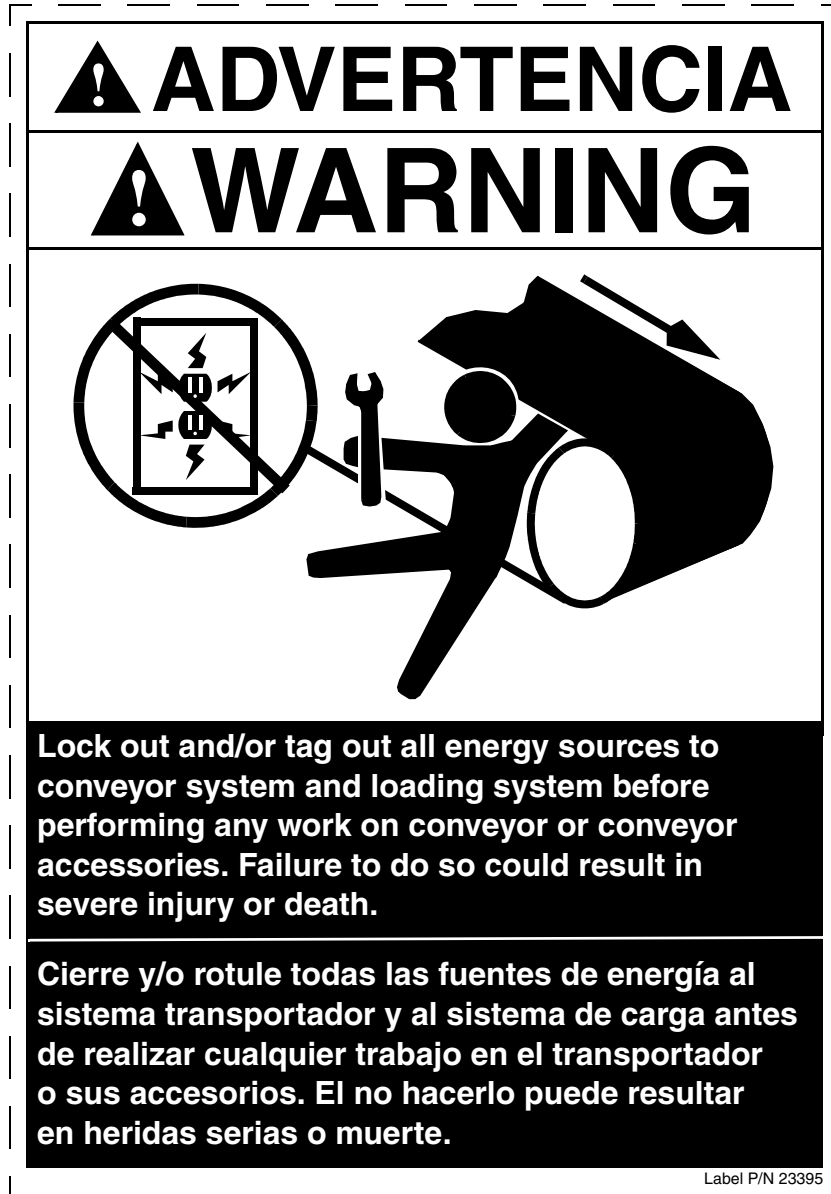
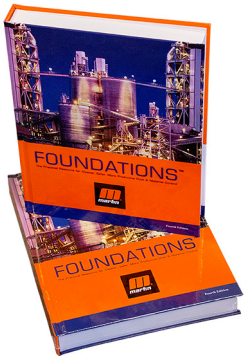

Figure 15. Martin® Conveyor Products Warning Label, P/N 23395

*Any product, process, or technology described here may be the subject of intellectual property rights reserved by Martin Engineering Company. Trademarks or service marks designated with the ® symbol are registered with the U.S. Patent and Trademark Office and may be proprietary in one or more countries or regions. Other trademarks and service marks belonging to Martin Engineering Company in the United States and/or other countries or regions may be designated with the “TM” and “SM” symbols. Brands, trademarks, and names of other parties, who may or may not be affiliated with, connected to, or endorsed by Martin Engineering Company, are identified wherever possible. Additional information regarding Martin Engineering Company’s intellectual property can be obtained at [www.martin-eng.com/trademarks](http://www.martin-eng.com/trademarks).*

# Problem Solved™ GUARANTEED!



*For nearly 30 years, Martin Engineering's Foundations™ Books have taught industry personnel to operate and maintain clean and safe belt conveyors. The Foundations™ Book, fourth edition, focuses on improving belt conveyors by controlling fugitive material. "The Practical Resource for Total Dust and Material Control," is a 576-page hard cover volume that provides information of value to industries where the efficient handling of bulk materials is a key to productivity and profitability.*

*Expanding upon the book, our Foundations™ Training Program addresses the design and development of more productive belt conveyors, and is offered in three customizable seminars. Attendees gain a better understanding of conveyor safety and performance, helping to justify upgrade investments and increase profitability.*



**Martin Engineering Australia Pty Ltd.**  
20 Ern Harley Dr - Burleigh Heads, QLD, 4220 - Australia  
1300 627 364  
[www.martin-eng.com.au](http://www.martin-eng.com.au)

