

2026 PRODUCT CATALOGUE

L4203

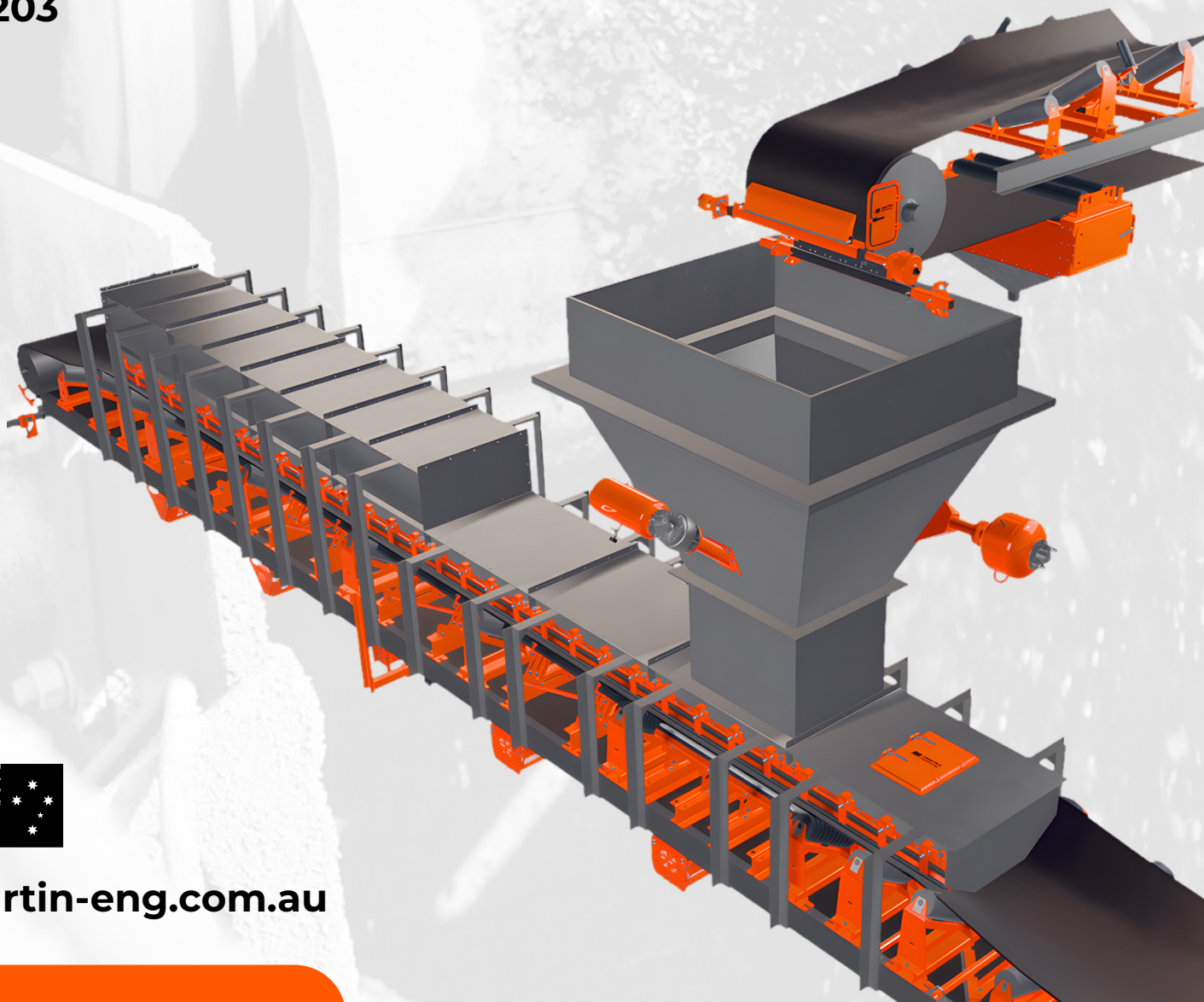



Cleaner, Safer, More Productive Bulk Material Handling Since 1944

Founded in 1944, Martin Engineering has grown from a modest family-owned entrepreneurial operation in the United States to the global leader in bulk material handling solutions. With an emphasis on innovation and customer satisfaction, we've developed cutting-edge technologies that improve efficiency, safety, and productivity across various industries. Over the years, we've expanded our reach to every corner of the globe, delivering high-quality products, services, and training to sectors including mining, processing, energy, and transportation.

With over 80 years of experience and proven results, we continue to set industry standards through our ongoing commitment to research and development. Our dedication to solving complex material handling challenges has earned us a trusted reputation with operations worldwide. Whether we're providing solutions to keep conveyor belts clean and aligned, control airborne dust and material spillage, or maintain proper material flow and throughput, our solutions are known for their reliability and performance, enhancing safety and fostering long-term partnerships with our customers across the globe.



Martin Engineering products, sales, service, and training are available from factory-owned facilities worldwide, supplemented by a strategic network of partners.

- Australia
- United States
- Brazil
- Central Asia
- Chile
- China
- Colombia
- France
- Germany
- India
- Indonesia
- Italy
- Kazakhstan
- Malaysia
- Mexico
- Middle East
- North & West Africa
- Peru
- Scandinavia & Baltic States
- Spain
- South Africa
- Turkey
- United Kingdom

BELT CLEANERS

Primary Belt Cleaners

CleanScape® Primary Cleaner 4
 QC1+™ Primary Belt Cleaners 5
 QC1+™ STS™ Primary Belt Cleaners . . . 5
 H1 Primary Belt Cleaner HD 6
 SHD Series Primary Belt Cleaners . . . 6
 ECOSAFE™ Primary Belt Cleaner 6
 Compact Primary Cleaner 7
 Tensioners 7
 Hanger Mounts & Mount Plates 8
 N2® Position Indicator 8
 Replacement Blades 9

Secondary Belt Cleaners

CleanScape® Secondary Cleaner 10
 Durt Hawg® DH2 Cleaner 10
 SQC2S™ Secondary Belt Cleaners 11
 SQC2S™ Cleaner STS™ 11
 SQC2S™ Reduced Mini Cleaner 11
 P2 & R2 Secondary Cleaners HD 12
 DT2 Reversing Cleaners 12
 ECOSAFE™ Secondary Cleaner 12
 UBX Secondary Cleaner 13
 Square Mainframe Tensioner 13
 Far Side Tensioner 13
 SQC2S™ Quick Access Door 13
 Pressure Roller Bracket 13
 Vibrating Dribble Chute 13

Specialty Belt Cleaners

Brush Cleaners 14
 Washbox™ Belt Cleaning System 15
 Torsion Arm Chevron Cleaner 15
 Food Grade Cleaner 15

Pulley Protection Plows

VPlow 16
 Torsion VPlow Plus 17
 Diagonal Plow 17

Services & Training

Walk The Belt™ 43
 Foundations™ Training 43

CONVEYOR PRODUCTS

Belt Alignment

Tracker™ 18
 Tracker™ Monster 19
 Tracker™ Reversing 19
 Roller Tracker™ 19

Belt Sealing

ApronSeal™ Skirting 20
 GravitySeal™ Self-Adjusting Skirting HD . 21
 Skirtboard Liner 21
 ApronSeal™ Urethane Skirting 21
 External Wear Liner 21

Belt Support

Impact Cradles 22
 High Speed Impact Cradle 23
 Combination Cradle 23
 Slider Cradle 24
 Trac-Mount™ Idlers 24
 Return Roller 24

Dust Management

Air Cleaner 25
 Dust Bag 25

Load Zone Containment

A.I.R. Control™ Dust Curtains 26
 Transfer Point Kits 27

Safety Accessories

Inspection Doors 28
 Conveyor Guard 29
 Return Roller Guard 29
 Return Roller Basket 29
 Urethane Chute Patch 29

FLOW AIDS

Air Cannons

Hurricane Air Cannon 30
 Typhoon Air Cannon 31
 Tornado Air Cannon 31
 Passport Air Cannon 31
 N2® Air Cannon Intelligence System . . 31
 Blow Pipes 32
 SMART™ Series Nozzles 32
 SMART™ Series Retractable Nozzle 360° . 32
 Thermo Safety Shield 32
 Nozzles 33
 Air Cannon Controller 33
 Mount Plates 33
 Air Cannon X-Stand 33
 Six Pack Program 33

Vibration Solutions

Ball Vibrators 34
 Roller Vibrators 35
 Turbine Vibrators 35
 Vibrotor™ CCR Vibrator 35
 Whirlwind Vibrator 35
 AP5 Series Piston Vibrators 36
 PV Series Piston Vibrators 36
 Thumper™ Timed Impactors 36
 2000 Series Piston Vibrators 37
 Brute® Vibrators 37
 MM & MC Series Electric Vibrators . . . 38
 Vertical Electric Vibrators 38
 Hydraulic Screen Vibrators 38
 Electric Screen Vibrators 38
 Cougar® DC Truck Vibrators 39
 Cougar® MDC Truck Vibrators 39
 Cougar® SDC Truck Vibrators 39
 THD Hydraulic Vibrators 39

Railcar Unloading

Boot-Lift® Railcar Connectors 40
 Railcar Opener 41
 Impacting Railcar Opener 41
 Gate Jack Railcar Opener 41
 Vibrotor™ CCR Railcar Vibrator 42
 3-in. Impacting Railcar Vibrator 42
 4-in. Impacting Railcar Vibrator 42
 Impacting Railcar Vibrator 42
 Non-Impacting Railcar Vibrator 42
 Vibrator Storage Stand & Cart 42

QR codes in this catalog provide direct links to product pages on Martin Engineering's website where technical documentation can be found.



PRIMARY BELT CLEANERS

Martin Engineering belt cleaners are the original standard in engineered belt cleaning. World class manufacturing, robust construction, and the highest-quality urethane on the market deliver unrivaled cleaning performance, durability, and reliability.

Multiple blade, tensioner, and mainframe options available to meet the unique demands of application requirements.



Scan code for more info and resources.

QC1+™ Primary Belt Cleaners

Patented constant angle radial pressure (CARP) blades ensure continuous and consistent cleaning performance across all stages of blade life and are available in six specialised urethane formulations to best suit the material being conveyed.

Patented blade holders allow blades to be cut to any length to perfectly match the material path.

Available with 1- or 3-piece mainframe* and Twist™ or Spring tensioner. Suitable for temperatures ranging from -30° to 180° F (-34° to 82° C).



Model	Max Belt Width in. (mm)	Max Belt Speed fpm (m/s)	Pulley Diameter in. (mm)
QC1+™ PV	72 (2000)	500 (2.5)	12-16 (300-400)
QC1+™ PD*	72 (2000)	900 (4.6)	16-22 (400-500)
QC1+™ HD	108 (2800)	900 (4.6)	16-22 (400-500)
QC1+™ HD Max	120 (3048)	1200 (6.0)	24-30 (610-762)
QC1+™ XHD	120 (3048)	1200 (6.0)	24-30 (610-762)

* PD model available in 1-piece mainframe only.

7 >> See page 7 for details about tensioner options.



Martin Engineering's patented QC1+™ blade design features a unique mounting interface that takes advantage of blade holders that allow blades to be cut to any length and mounted to the mainframe to perfectly match the material path.

Blades that match the material path of the conveyor system provide the most effective cleaning by ensuring the proper contact with the belt and reducing uneven blade wear and unnecessary wear of the belt surface, extending equipment life.

CleanScrape® Primary Cleaner

CleanScrape® provides unmatched cleaning performance and is guaranteed to last up to four times longer than any other belt cleaner with periodic re-tensioning or adjustment required over the life of the blade. CleanScrape® provides the lowest operating cost with the greatest return on investment over the life of the cleaner. Covered by our industry-best *Absolutely No Excuses Money-Back Guarantee!*

Installed at a 3-dimensional helix angle across the face of the discharge pulley, this revolutionary cleaner requires minimal space for installation. Because it's equipped with tungsten carbide tips and applies minimal pressure to the belt, CleanScrape® is safe for use on mechanical splices, making it the most versatile belt cleaner on the market.



Max Belt Width in. (mm)	Max Belt Speed fpm (m/s)	Pulley Diameter in. (mm)
120 (3000)	1500 (7.5)	12-78 (300-2000)

10 >> See page 10 for CleanScrape® Secondary Cleaner.



>> See CleanScrape® Cleaners in action.

CleanScrape® Heated Primary Cleaner

Features internal heating elements throughout the body of the blade to prevent material buildup on the blade itself. Available for medium and large blade sizes with B-carbide cleaning element.

Max Belt Width in. (mm)	Max Belt Speed fpm (m/s)	Pulley Diameter in. (mm)
96 (2400)	1500 (7.5)	22-50 (560-1270)

QC1+™ Safe-To-Service (STS™) Primary Belt Cleaners

Designed for rugged conditions, this sturdy cleaner's stainless steel mandrel allows the blade cartridge to be safely serviced from outside the chute wall or conveyor structure without confined space entry or breaking the safety plane. Changing the blade is a simple one-pin operation, making replacement of a worn blade safe and simple.

Available with original patented CARP blades in six specialised urethane formulations to best suit the material being conveyed and ensure continuous and consistent cleaning performance across all stages of blade life.

Available with spring or air tensioners and suitable for temperatures ranging from -30° to 300° F (-34° to 149° C).

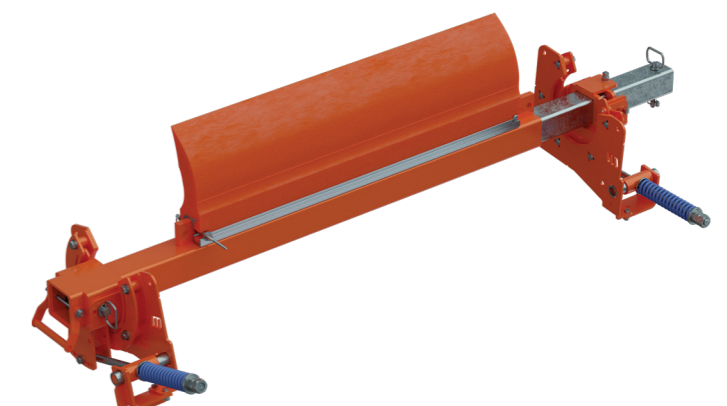

Model	Max Belt Width in. (mm)	Max Belt Speed fpm (m/s)	Pulley Diameter in. (mm)
QC1+™ HD STS™	72 (2000)	900 (4.6)	16-22 (400-500)
QC1+™ XHD STS™	72 (2000)	1200 (6.1)	24-30 (600-760)

11 >> See page 11 for STS™ Secondary Cleaner.

H1 Primary Belt Cleaner HD

Martin Engineering's H1 Primary Belt Cleaner HD is a robust, durable, and highly effective conveyor belt cleaning system. Built with precision-cast stainless steel components and abrasion-resistant tungsten carbide tips, it offers one of the most cost-efficient cleaning solutions in the industry.

Designed to efficiently remove carryback, it is suitable for most material types, with tungsten carbide tips delivering exceptional performance, particularly when cleaning abrasive materials or operating on high-speed conveyor belts.

However, tungsten carbide tips are not recommended for conveyor belts equipped with mechanical fasteners or belts with significant cover damage.

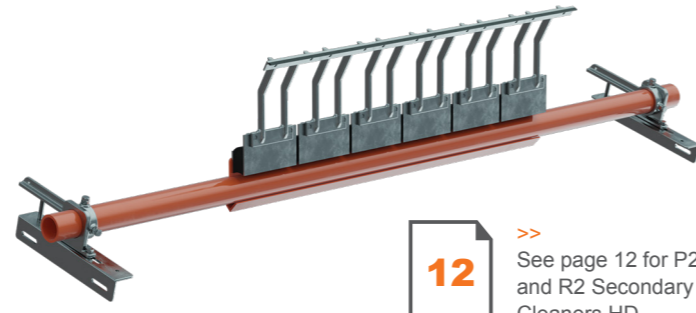

12 >> See page 12 for P2 and R2 Secondary Cleaners HD.

Max Belt Width in. (mm)	Max Belt Speed fpm (m/s)	Pulley Diameter in. (mm)
102 (2500)	1500 (7.5)	10-66 (250-1700)

SHD Series Primary Belt Cleaners

Designed and engineered specifically for the punishing demands of super heavy-duty mine-grade applications, SHD Series Cleaners offer rugged structural steel mainframes, robust turnbuckle tensioners, and massive high-performance urethane blades providing up to 12 full inches (305 mm) of wear life without need for re-tensioning or adjustment for the life of the blade.

Available with patented CARP blades in two specialised urethane formulations, including an MSHA (USA)-approved (IC-95/6) formula for underground applications, to ensure continuous and consistent cleaning performance across all stages of blade life.



Model	Max Belt Width in. (mm)	Max Belt Speed fpm (m/s)	Pulley Diameter in. (mm)
SHD 600 Series	120 (3000)	1500 (7.5)	24-48 (600-1200)
SHD 1200 Series	120 (3000)	1500 (7.5)	48+ (1200+)

ECOSAFE™ Primary Belt Cleaner

Designed for heavy-duty applications, the innovative ECOSAFE™ Primary Cleaner features a unique split track blade cartridge design that significantly reduces urethane waste, simplifies blade replacement, and improves safety.

The interface between the blade and the cartridge has been completely redesigned to require 26% less urethane in the base of the blade, resulting in lighter, easier-to-handle blades and 60% less discarded urethane from a used blade.

Blade changes require standard tools, and the cartridge slides out from the mainframe to allow maintenance to be performed outside of the chute, reducing downtime and improving safety.

Available with either air or spring tensioners and suitable for use on reversing belts.



12 >> See page 12 for ECOSAFE™ Secondary Cleaner.

Belt Width in. (mm)	Max Belt Speed fpm (m/s)	Pulley Diameter in. (mm)
18-96 (450-2400)	1200 (6)	24 (600) and up

Compact Primary Cleaner

Designed for applications on small pulleys, the Compact Cleaner offers a low-profile blade mounted on an internal square mainframe for effective belt cleaning in tight spaces.

Available with patented CARP blades in five specialised urethane formulations to best suit the material being conveyed and ensure continuous and consistent cleaning performance across all stages of blade life.



Max Belt Width in. (mm)	Max Belt Speed fpm (m/s)	Pulley Diameter in. (mm)
55 (1400)	350 (1.8)	6-10 (152-250)



Visit our online **Foundations™ Learning Centre** for free articles, videos, e-books, and blog posts offering a variety of information including selection guides, maintenance checklists, troubleshooting tips and tricks, and much more. >> foundations.martin-eng.com/en/knowledge

Tensioners

Martin® Belt Cleaner Tensioners provide the most robust and rugged construction to maintain reliable and proper blade-to-belt tension to ensure unmatched belt cleaning performance while providing ease-of-service and minimal maintenance.

The patented Martin® Twist™ Tensioner uses energy from a twisted rubber coupling to supply consistent belt cleaning pressure with minimal adjustment and can be used on either primary or secondary cleaners.

The Twist™ Tensioner allows mechanical splices to pass without damage. In the event that the blade pulls through, the tensioner's coupling rolls over, releasing pressure and reducing the risk of harm to personnel or equipment.

A light-weight aluminum housing and the fully-enclosed design keeps the tensioner mechanism clean. Simple adjustment involves twisting the tensioning gear the specified number of notches (determined by belt width). The ratchet will automatically lock in place.

Spring Tensioners maintain efficient belt cleaning with a rugged coil spring providing visibility of the tensioning mechanism. Air Tensioners utilise plant air to deliver and maintain consistent, reliable blade-to-belt pressure without a mechanical device.

Dual tensioning is recommended for belt cleaners installed on belts wider than 48 inches (1200 mm). Mounts and tensioners can be purchased individually or in packages with various belt cleaning systems.



Twist™ Tensioner

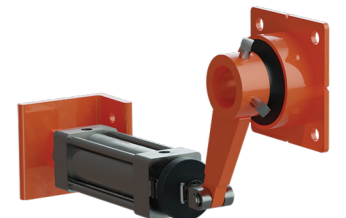

Air Cylinder Tensioner



Spring Tensioner



Spring Tensioner XHD



>> See Martin® Belt Cleaners in action.



Visit Martin Engineering's official **Sketchfab site** to view interactive 3D visualisations of our entire portfolio of products, offering a unique and immersive digital experience in which to explore key products features and construction. >> sketchfab.com/martinengineering

Hanger Mounts & Mount Plates



Hanger Mount for XHD Spring Tensioner P/N: 27382-SL
 Hanger Mount for Twist™ Tensioners P/N: 27382
 Heavy Duty Hanger Mount for Secondary Cleaners P/N: 34233-HD

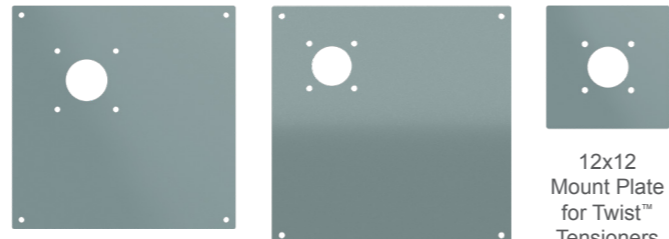

Mount Plate for XHD Spring Tensioners P/N: 39456-PXH02
 Mount Plate for Twist™ Tensioners P/N: 39456-P2
 12x12 Mount Plate for Twist™ Tensioners P/N: 39487-P

Martin® Hanger Mounts provide the framework to install a conveyor belt cleaner and tensioner assembly on open head-pulley belt conveyors without an enclosed chute, providing the necessary support to achieve and maintain proper and effective cleaning position.

Mount Plates provide the necessary surface with predrilled and cut holes to mount tensioners when adequate chutewall is not available.



Visit our **On-Demand Webinar Library** for dozens of free on-demand video recordings covering a wide variety of topics including belt conveyor optimisation, carryback and belt cleaning, material flow, dust control, and safety and culture. >> foundations.martin-eng.com/webinars-on-demand

N2® Position Indicator



The intuitive N2® Position Indicator allows for remote monitoring of the belt cleaner blade via Martin's proprietary mobile app and desktop dashboard, indicating remaining blade life, notifying when re-tensioning or replacement is required, and warning in the event that the blade is no longer in contact with the belt.

The N2® Position Indicator is capable of collecting data and providing insights for any belt cleaner utilising a Martin® blade.

Insights gained from remote monitoring makes maintenance more efficient, takes the guesswork out of replacement blade ordering and inventorying, and reduces worker exposure to belt conveyor hazards.

The N2® Gateway receives information from up to 200 N2® Position Indicators and transmits information to the cloud for monitoring via the Martin® Smart Device Manager mobile application.

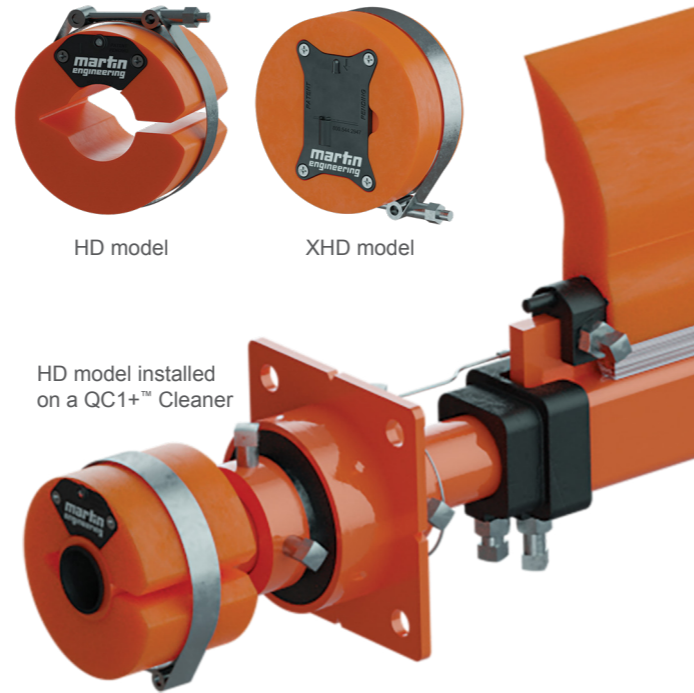

HD model installed on a QC1+™ Cleaner



HD model



XHD model

Genuine Martin® Belt Cleaner Replacement Blades

One of Martin Engineering's defining characteristics and core strengths is our expertise in urethane formulation and production.

Martin Engineering is the original and industry-leading manufacturer of specialty urethanes for heavy-duty, high-performance belt conveyor components, including belt cleaner blades, chute liners, and impact and support bars. We offer the highest-quality urethane products, formulated in Neponset, Illinois, USA, and manufactured in Australia.

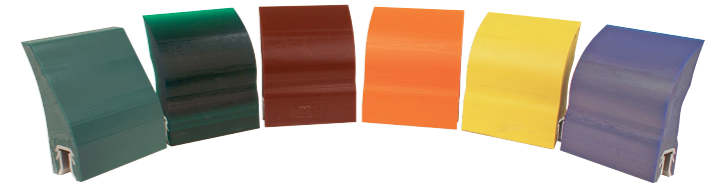

Urethane	Color	Duro-meter	Application Conditions	Temperature Range
Standard	Orange	83	Suitable for most applications, including abrasive conditions and exposure to solvents or oil. For use with materials such as coal, ore, bauxite, coke, refuse.	-20° to 180°F (-30° to 80°C)
High-Temp	Green	83	For use with high temperature materials such as clinker. Can handle intermittent temperatures of 350°F (177°C).	-40° to 300°F (-40° to 150°C)
Chemical Resistant	Brown	86	Improved resistance to chemicals and reduces water absorption for high moisture environments such as limestone. Best choice for applications exposed to chemicals with pH as high as 11 and as low as 4.	-40° to 180°F (-40° to 80°C)
Low Rigidity	Tan	87	For use with dry products such as sand and gravel.	-20° to 180°F (-30° to 80°C)
Low Adhesion	Navy Blue	91	For use with sticky or tacky products such as cement, glass, and wood chips.	-20° to 180°F (-30° to 80°C)

Our unrivaled product quality is informed by decades of research and development and ensured by our state-of-the-art production process completed start-to-finish under one roof by the industry's foremost experts.

Martin Engineering's unique CARP blade design provides Constant Angle Radial Pressure to ensure consistent cleaning throughout the entire wear life of the blade, maximising return on your investment and delivering unrivaled reliability without degradation in performance. Martin® replacement blades provide up to 53% more wearable urethane than competitive blades for maximum blade life.

Specially-formulated, color-coded urethanes are available to best suit any application. Blades available for all major manufacturers including:

- American Eagle® E4 & E5
- Arch Saber®
- Argonics Eraser™
- ASGCO® Skalper®
- Benetech® BEP1
- Flexco® EZP1 Rockline®
- Flexco® H-Type®
- Flexco® P-Type®
- Flexco® R-Type®
- Flexco® MMP
- Richwood® 1C & 1C-ITC
- Superior Exterra®

American Eagle® is a registered trademark of American Eagle Manufacturing, LLC., New Bern, NC. Saber® is a registered trademark of Arch Environmental Equipment Inc., Paducah, KY. Argonics™ and Eraser™ are trademarks of Argonics Inc., Marquette, MI. ASGCO® and Skalper® are registered trademarks of ASGCO Mfg, Inc., Allentown, PA. BENETECH® are registered trademarks of Benetech Inc., Aurora, IL. Flexco® and Rockline® are registered trademarks of Flexible Steel Lacing Company, Downers Grove, IL. Richwood® is a registered trademark of Richwood Industries, Inc., Huntington, WV. Exterra® is a registered trademark of Superior Industries Inc., Morris, MN.



Visit our website to download our **Foundations™ Books**, industry-standard textbooks for cleaner, safer, and more productive conveyor operation and maintenance, along with e-books covering a variety of specific bulk material handling and material flow topics. >> foundations.martin-eng.com/book-options



SECONDARY BELT CLEANERS

Secondary cleaners are installed with the cleaning edge at a scraping angle with high blade-to-belt pressure behind the head pulley where the belt is at its flattest, providing an ideal surface to effectively clean.

Secondary cleaners are much better suited to scrape off the remaining smaller particles and higher-moisture carryback that primary cleaners can't remove. A properly specified, installed, and maintained multiple-cleaner system can reliably achieve 90 to 95% carryback removal from the conveyor belt.



Scan code for more info and resources.

CleanScrape® Secondary Cleaner

The CleanScrape® Secondary Cleaner is an all stainless steel assembly featuring independent 6-inch wide blades with carbide tips. Each tip is supported on spring-loaded arms at both ends. The load springs allow independent blade rotation back and forward as well as up and down.

This range of motion provides equal load pressure across each blade, absorbs obstructions, conforms to ever-changing belt undulations, and arcs safely in the event of belt rollback.



>> See CleanScrape® Secondary in action.

Belt Width in. (mm)	Max Belt Speed fpm (m/s)
18-96 (450-2400)	900 (5.0) for vulcanised splices 600 (3.0) for mechanical splices

Durt Hawg® DH2 Cleaner

The original engineered secondary belt cleaner, the Durt Hawg® is an established industry workhorse. High-volume blades provide improved cleaning efficiency and longer wear life while a sturdy mainframe withstands tough conditions.

Simple design requires only a hammer to mount the steel cleaning blades which are set into rugged, one-piece molded urethane arms that absorb impact and allow splices to pass without damage.

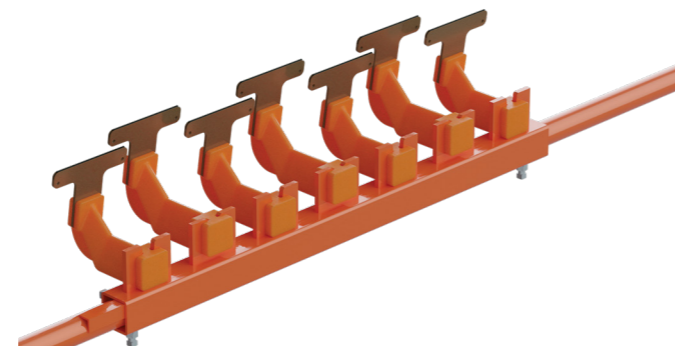

Belt Width in. (mm)	Max Belt Speed fpm (m/s)	Temperature °F (°C)
18-96 (450-2400)	750 (3.8)	-30° to 180° (-34° to 82°)

SQC2S™ Secondary Belt Cleaners

The most versatile and best-selling secondary cleaner on the market, SQC2S™ is a reliable and proven solution for a broad range of demanding applications across virtually every industry. Its rugged construction withstands harsh environments, high-speed belts, and high-tonnage loads.

The SQC2S™ Secondary Belt Cleaner offers five unique, easy-to-service blade cartridge options to match the needs of your application.

Available with acid-resistant blades for belts with clips and suitable for use with reversing belts.

Belt Width in. (mm)	Max Belt Speed fpm (m/s)	Temperature °F (°C)
18-96 (450-2400)	1500 (7.5)	-30° to 300° (-34° to 149°)



>> See SQC2S™ Belt Cleaners in action.



>> See page 5 for Safe-To-Service™ Primary Cleaners.

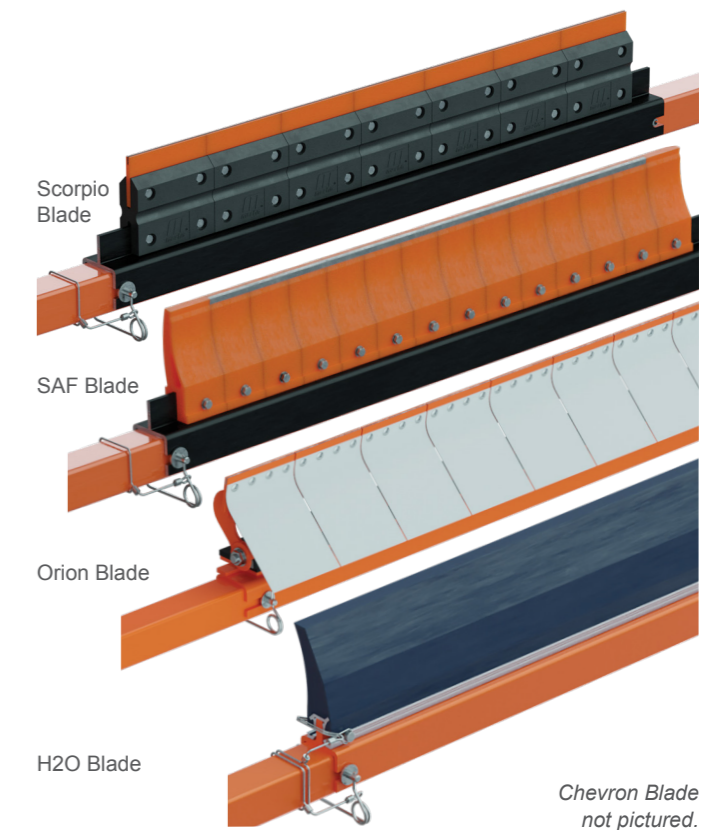

Chevron Blade not pictured.

SQC2S™ Cleaner STS™

The Safe-To-Service (STS™) version of the industry-leading SQC2S™ Cleaner features an extended cartridge, allowing the blade cartridge to be serviced without confined space entry or breaking the safety plane. A Farside Tension Adjuster allows all adjustments to be made from the operator's side of the belt.

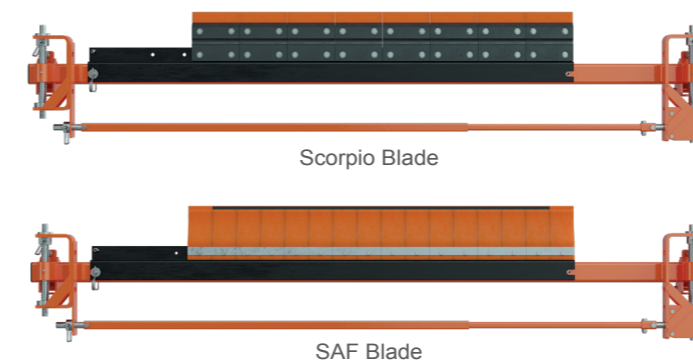

Belt Width in. (mm)	Max Belt Speed fpm (m/s)	Temperature °F (°C)
18-96 (450-2400)	1500 (7.5)	-30° to 300° (-34° to 149°)

SQC2S™ Reduced Mini Cleaner

Compact design allows installation in close quarters while the narrow profile resists material buildup.

Individually-cushioned tungsten carbide blades deliver effective and reliable cleaning performance while cushioning impact and accommodating reversing belt direction, eliminating risk to the belt, splice, or blade.



Belt Width in. (mm)	Max Belt Speed fpm (m/s)	Temperature °F (°C)
18-96 (450-2400)	750 (3.8)	-30° to 300° (-34° to 149°)

P2 & R2 Secondary Belt Cleaners HD

The P2 Secondary Cleaner HD and R2 Secondary Cleaner HD are robust, durable, and highly effective cleaning systems. Built with precision-cast stainless steel components and abrasion-resistant tungsten carbide tips, they deliver reliable performance while remaining amongst the most cost-effective belt cleaning options available.

Designed for versatility, these cleaners are suitable for most material types. Tungsten carbide-tipped secondary cleaners offer consistently high performance and are especially effective in removing abrasive materials from high-speed conveyor belts.

R2 Secondary Cleaner HD is also suitable for reversing belts, trippers, and shuttles.



6 >> See page 6 for H1 Primary Cleaner HD.

Max Belt Width in. (mm)	Max Belt Speed fpm (m/s)
102 (2500)	1500 (7.5)

DT2 Reversing Secondary Cleaners

DT2 Reversing Cleaners feature a split-track blade cartridge that slides in and out on a rugged stainless steel mandrel, making service fast and easy to reduce conveyor downtime.

DT2S features a lean profile, allowing installation in spaces as narrow as seven inches (178 mm).

DT2H features massive extra-heavy duty blades ideal for challenging conditions, including heavy loads and high belt speeds.

Model	Belt Width in. (mm)	Max Belt Speed fpm (m/s)	Temperature °F (°C)
DT2S	24-120 (500-3048)	900 (4.6)	-30° to 300° (-34° to 149°)
DT2H XHD	18-120 (450-3048)	1200 (6.1)	-30° to 300° (-34° to 149°)



ECOSAFE™ Secondary Cleaner

Designed for heavy-duty applications, the innovative ECOSAFE™ Secondary Cleaner features a unique split track blade cartridge design that significantly reduces urethane waste, simplifies blade replacement, and improves safety.

The interface between the blade and the cartridge has been completely redesigned to require 36% less urethane in the base of the blade, resulting in lighter, easier-to-handle blades and 56% less discarded urethane from a used blade.

Blade changes require standard tools, and the cartridge slides out from the mainframe to allow maintenance to be performed outside of the chute, reducing downtime and improving safety.

Available with either air or spring tensioners and suitable for use on reversing belts and operating temperatures up to 300°F (150°C).



6 >> See page 6 for ECOSAFE™ Primary Cleaner.

Belt Width in. (mm)	Max Belt Speed fpm (m/s)
18-96 (450-2400)	1200 (6)

UBX Secondary Cleaner

Solid, one-piece urethane blade—with or without embedded metal cleaning element—provides highly wear-resistant cleaning performance for long wear life on high-speed, high-tonnage, mine-duty belts. Mechanical spring tensioners require minimal maintenance while providing reliable cleaning performance. Air tensioners also available.

Belt Width in. (mm)	Max Belt Speed fpm (m/s)
24-96 (610-2400)	1200 (6) and up

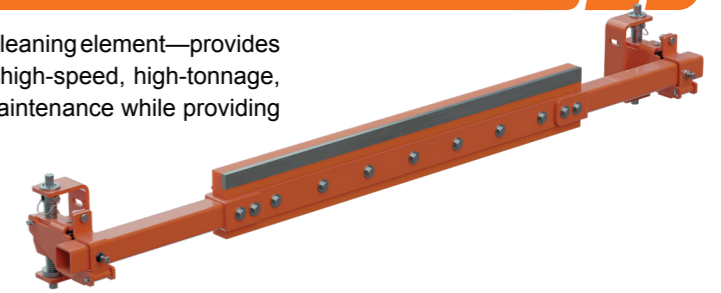

Square Mainframe Tensioner

Provides uniform tension for square mainframe secondary belt cleaners to deliver reliable, high-performance cleaning while requiring minimal adjustment over the life of the blade.

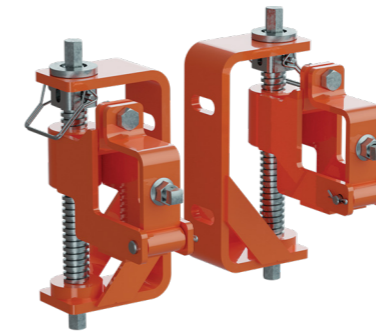

Far Side Tensioner

Provides a simple, hand-operated way to evenly tension both sides of a conveyor belt cleaning system from one side. This unique mechanical device allows for quick adjustment of secondary belt cleaners in tight spaces, improving maintenance safety by eliminating the need to climb over belts or use unsafe methods.

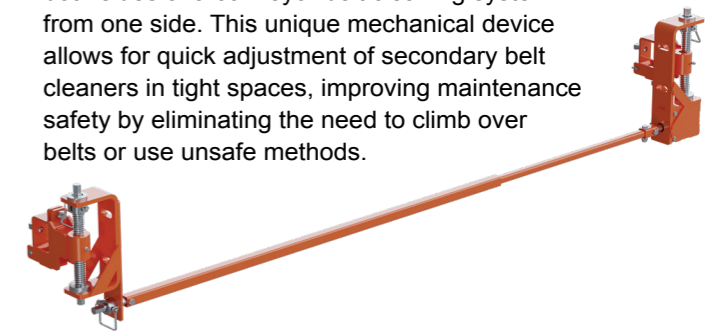

SQC2S™ Quick Access Door

Split cover urethane door held securely in place on chute structure or mount plates with embedded magnets to provide a durable and reliable shield around SQC2S™ Secondary Cleaner mainframes while allowing easy, no-tool access for inspection and maintenance. Integrated tether secures top and bottom halves together during removal. Max application temp 300° F.



28 >> See Inspection Doors in action.

28 >> See page 28 for additional door models.

Pressure Roller Bracket

The Pressure Roller Bracket stabilises the conveyor belt, providing proper pressure for multiple conveyor belt scraper installations or where space limitations prevent installation on head pulley so the cleaner(s) can be tensioned without lifting the belt.

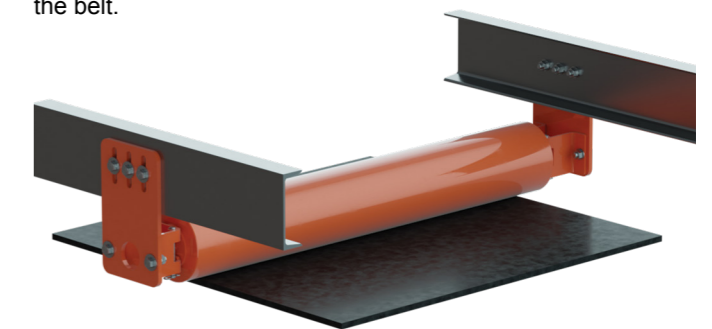

Designed with slotted bolt holes to simplify installation on conveyor structure. Supplied with a roller or can be used with existing conveyor equipment. Available for either "arm-and-blade" or vertically-tensioned secondary cleaner systems.

Vibrating Dribble Chute

The Martin® Vibrating Dribble Chute uses an electric vibrator and a low adhesion plastic liner to keep material from clogging chutes and burying belt cleaners. Low-friction plastic lining promotes material flow without accumulation while the rubber-lined bracket transfers vibration to liner without metal fatigue.



34 >> See page 34 for our full range of vibration solutions.



SPECIALTY BELT CLEANERS

Installed mainly as secondary belt cleaners, Martin Engineering's specialty belt cleaners include products engineered to perform under the most challenging conditions, such as extreme temperatures, as well as suited for food grade applications. Products are also available that perform with varying types of belts, including ribbed, flighted, grooved, or chevron conveyor belts.



Scan code for more info and resources.

Brush Cleaners

Effective cleaning performance on difficult applications, including belts with ribs, cleats, grooves, or chevrons, or belts carrying sticky materials or stringy fibers.

Efficient electric motor provides effective cleaning with powered rotary action without excessive power consumption. Durable angle iron and stainless steel components provide long service in tough conditions.

Strip Brush Cleaner uses 12 brush strips assembled on a series of hubs mounted on a shaft to form a 10-inch diameter brush. Strip brush design allows material to fall off the brush rather than settle into the bottom of the bristles. Design allows simple replacement of individual brush strips.

Spiral Brush Cleaner features bristles wrapped in a continuous spiral around brush shaft to deliver effective cleaning performance on dry fines clinging to belts with cleats, chevrons, or ribs.

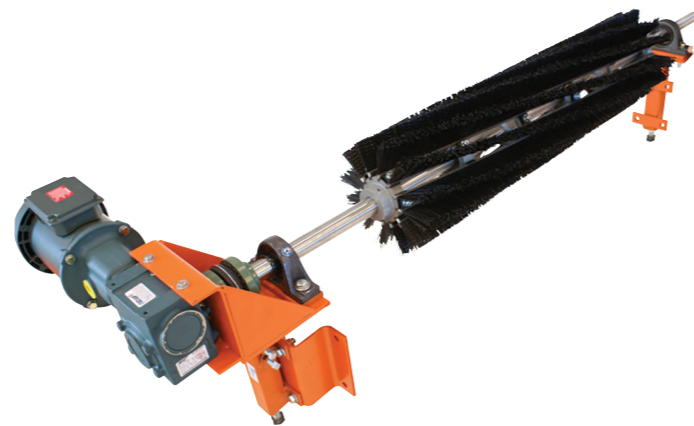

Model	Max Belt Width in. (mm)	Max Belt Speed fpm (m/s)	Temperature °F (°C)
Strip Brush	60 (1800)	500 (2.5)	-30° to 180° (-34° to 82°)
Spiral Brush	72 (2000)	500 (2.5)	-30° to 180° (-34° to 82°)

Washbox™ Belt Cleaning System

Installed as a secondary cleaner along the conveyor's return run, the Martin® Washbox™ Cleaning System provides the ultimate in belt cleaning technology. The Washbox™ gently spray-applies water for superior belt cleaning.

Single-cleaner system consists of a powder-coated steel enclosure equipped with one roller, one spray bar, two inspection doors, and one secondary cleaner.

Dual-cleaner system consists of a powder-coated steel enclosure equipped with three rollers, four spray bars, four inspection doors, and two secondary cleaners.

Single-cleaner and stainless steel washbox options available, as well as Martin Engineering's full range of high-performance urethanes. Belt cleaners are also available with tungsten carbide, stainless steel, or urethane blades.

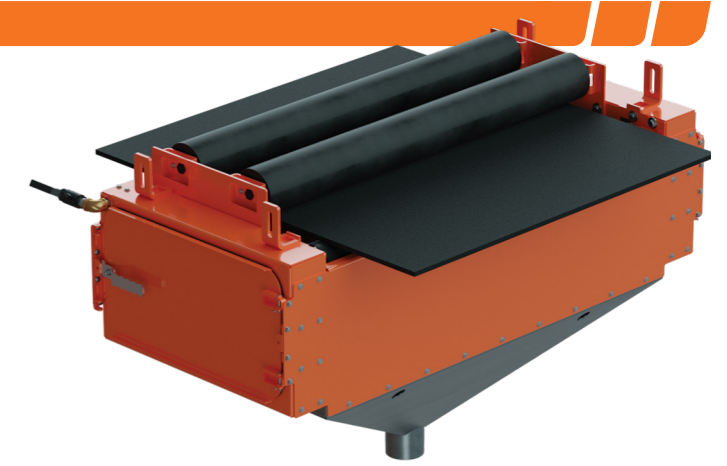

Belt Width in. (mm)	Max Belt Speed fpm (m/s)
18-84 (400-2200)	750 (3.8)



Visit Martin Engineering's official **YouTube channel** to view a selection of hundreds of long- and short-form videos offering a range of content from expert insights and webinar excerpts to product highlights and case studies, and much more. >> youtube.com/@martinengineering

Torsion Arm Chevron Cleaner

The Martin® Torsion Arm Chevron Cleaner features 30° offset arms with either rubber or urethane blades to effectively remove carryback while gently stepping over belts with ribs, chevrons, and cleats.



Belt Width in. (mm)	Max Belt Speed fpm (m/s)	Temperature °F (°C)
18-96 (400-2400)	500 (2.5)	-30° to 180° (-34° to 82°)

Food Grade Cleaner

Martin® Food Grade Belt Cleaner fits requirements of belt conveyors in food processing and packaging. Available as either a primary or secondary cleaner with high-density polyethylene or nylon blades on stainless steel mainframes with either an air, spring, or hub mount tensioner.



Belt Width in. (mm)	Max Belt Speed fpm (m/s)	Temperature °F (°C)
4-48 (100-1200)	350 (1.8)	-40° to 380° (-40° to 193°)



Visit Martin Engineering's official **Sketchfab site** to view interactive 3D visualisations of our entire portfolio of products, offering a unique and immersive digital experience in which to explore key products features and construction. >> sketchfab.com/martinengineering



PULLEY PROTECTION PLOWS

Martin Engineering's pulley protection products are designed to prevent material that has landed on the inside of the belt during the return from being pulled into the tail pulley. If it isn't removed, the material can cause extensive damage to the entire conveyor system, especially the tail pulley and the belt.

Our pulley protection products, which are designed to plow discharge material to the side of the belt for easy control and cleanup, are available for standard and reversing belts, with self-adjusting models that rise and fall with fluctuations in belt tension. We also offer products designed for varying speeds and belt widths.



Scan code for more info and resources.

VPlow

The VPlow is an effective and economical solution for belt and pulley protection from medium- to heavy-duty applications. The VPlow floats on the inside surface of a conveyor belt to reliably remove stray material. The self-adjusting design provides effective cleaning through all stages of blade wear.

Low-profile rugged steel frame construction bolts together for easy installation and stands up to the toughest applications.

Easily replaceable blades are available in 60 Shore A Durometer Nitrile rubber or a variety of long-wearing 90 Shore A Durometer urethanes to match application and material requirements. Tough one-piece urethane bull nose provides long-lasting life and easy replacement.



Model	Belt Width in. (mm)	Max Belt Speed fpm (m/s)	Wearable Blade in. (mm)
Modular	18-120 (450-2800)	900 (4.6)	2 (51)
Heavy Duty	18-120 (450-2800)	900 (4.6)	2 (51)
Extra Heavy Duty	42-120 (1000-2800)	1000+ (5.0)	3 (76)



Visit our online **Foundations™ Learning Centre** for free articles, videos, e-books, and blog posts offering a variety of information including selection guides, maintenance checklists, troubleshooting tips and tricks, and much more. >> foundations.martin-eng.com/en/knowledge

Torsion VPlow Plus

The Martin® Torsion VPlow Plus is mounted with a unique yet simple two-point centre mount suspension that provides both constant positive pressure and maximum flexibility to allow the plow to rise and fall with fluctuations in belt tension and travel. This self-adjusting function provides the most effective and reliable cleaning through all stages of blade wear.

Low-profile rugged steel frame construction bolts together for easy installation and stands up to the toughest applications.

Easily replaceable blades are available in 60 Shore A Durometer Nitrile rubber or a variety of long-wearing 90 Shore A Durometer urethanes to match application and material requirements. Tough one-piece urethane bull nose provides long-lasting life and easy replacement.

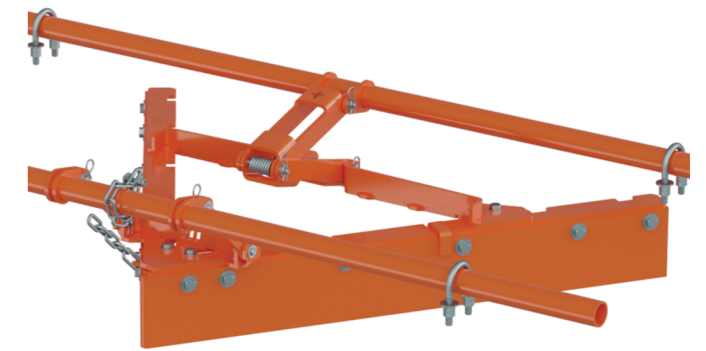

Belt Width in. (mm)	Max Belt Speed fpm (m/s)	Wearable Blade in. (mm)
18-120 (450-2800)	900 (4.6)	2 (51)



Visit our **On-Demand Webinar Library** for dozens of free on-demand video recordings covering a wide variety of topics including belt conveyor optimisation, carryback and belt cleaning, material flow, dust control, and safety and culture. >> foundations.martin-eng.com/webinars-on-demand

Diagonal Plow

Hung from brackets on both sides of the conveyor, the Martin® Diagonal Plow's durable 60 shore A durometer nitrile rubber blade floats on the belt surface to remove material in either direction of belt travel without needing adjustment.

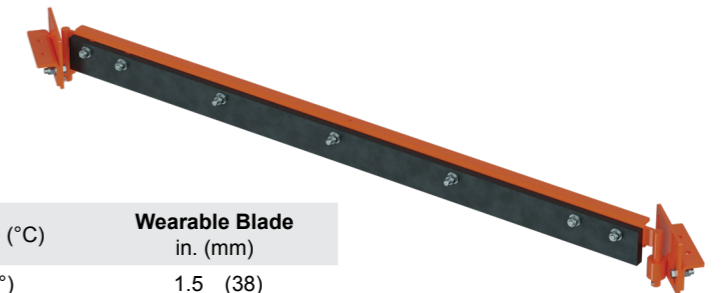

Belt Width in. (mm)	Max Belt Speed fpm (m/s)	Max Temp °F (°C)	Wearable Blade in. (mm)
18-120 (400-3000)	900 (4.6)	250° (21°)	1.5 (38)



Visit our website to download our **Foundations™ Books**, industry-standard textbooks for cleaner, safer, and more productive conveyor operation and maintenance, along with e-books covering a variety of specific bulk material handling and material flow topics. >> foundations.martin-eng.com/book-options



BELT ALIGNMENT

By keeping belts tracked correctly, you can keep material in the flow stream and eliminate runaway dust. Martin Engineering's belt alignment products provide immediate, continuous precision adjustment that keeps conveyor belts perfectly aligned, even withstanding the stress caused by wider, thicker belts carrying heavier loads at high speeds.

Our belt tracking products prevent edge damage, extend belt life, reduce spillage, and minimise wear and tear on equipment. Plus, we manufacture trackers that can sense the direction of the belt's movement and make the adjustments needed to keep reversing conveyors correctly centred.



Scan code for more info and resources.

Tracker™

The Martin® Tracker™ is the most reliable and effective solution to provide immediate and continuous precision adjustment for wandering conveyor belts.

Unlike other belt training devices, the Tracker™ excels in reducing edge damage, preventing spillage, and extending belt life. Its automatic, continuous adjustments keep the belt in consistent alignment, ensuring improved tracking that significantly reduces maintenance expenses.

The Tracker™ features a patented parallel steering/training system for precise, ongoing adjustment, maintaining optimal belt alignment and operational efficiency at all times.

Model	Belt Width in. (mm)	Max Belt Thickness in. (mm)	Max Belt Speed fpm (m/s)
Standard Duty	24-54 (500-1600)	0.5625 (14.3)	400 (2.0)
Heavy Duty	36-72 (800-2000)	1.125 (28.5)	800 (4.0)



Visit our website to download our **Foundations™ Books**, industry-standard textbooks for cleaner, safer, and more productive conveyor operation and maintenance, along with e-books covering a variety of specific bulk material handling and material flow topics. >> foundations.martin-eng.com/book-options

Tracker™ Monster

The Martin® Tracker™ Monster is specially designed to provide reliable and effective tracking on wider, thicker, and faster belts to provide immediate and continuous precision adjustment to counter misalignment.

The Tracker™ Monster features a patented parallel steering/training system for precise, ongoing adjustment, maintaining optimal belt alignment and operational efficiency at all times.

Belt Width in. (mm)	Max Belt Thickness in. (mm)	Max Belt Speed fpm (m/s)
54-96 (1400-2400)	≥1.125 (28.5)	1000 (5.0)

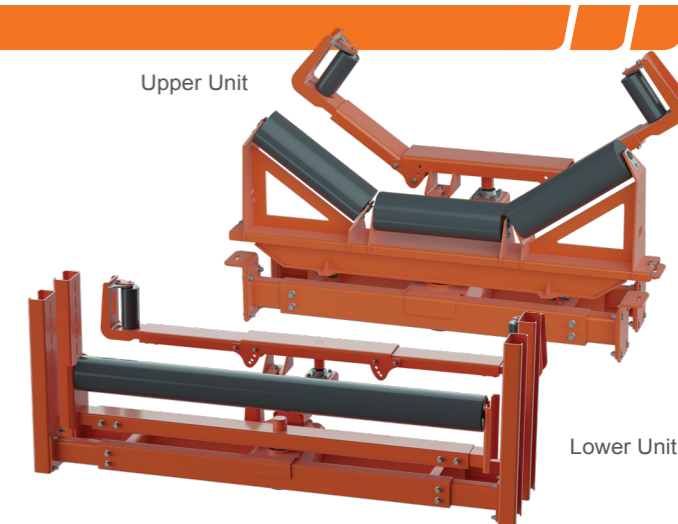

Tracker™ Reversing

The Martin® Tracker™ Reversing is a state-of-the-art solution offering immediate and continuous precision adjustment for reversing conveyors that are challenging to track. This innovative system ensures the belt stays perfectly centred regardless of its direction of travel.

The Tracker™ Reversing is equipped with sensing rollers and lever arms at both ends and utilises a stainless steel lamella, or paddle wheel, to accurately detect the belt's direction and activate the appropriate sensing rollers.

This advanced technology guarantees optimal belt alignment, enhancing operational efficiency and reducing maintenance needs for reversing conveyor systems.

Belt Width in. (mm)	Max Belt Thickness in. (mm)	Max Belt Speed fpm (m/s)
24-84 (600-2200)	0.5625 (14.3)	700 (3.5)



Roller Tracker™

The Martin® Roller Tracker™ is engineered to meet the rigorous demands of conveyor belt tracking with unparalleled precision and reliability.

Designed for ease of installation and minimal maintenance, it ensures a smooth, vibration-free rolling action that enhances operational efficiency. Featuring superior bearings for exceptional quality, the Roller Tracker™ guarantees reliable performance tailored to customer needs on belt widths from 20-72 inches (500-1650 mm).

Its innovative design eliminates contact with the belt edge, preventing wear and extending belt life. With polyurethane lagging enhancing durability, this tracker delivers long-lasting reliability and optimal belt alignment. Suitable for reversing belts.

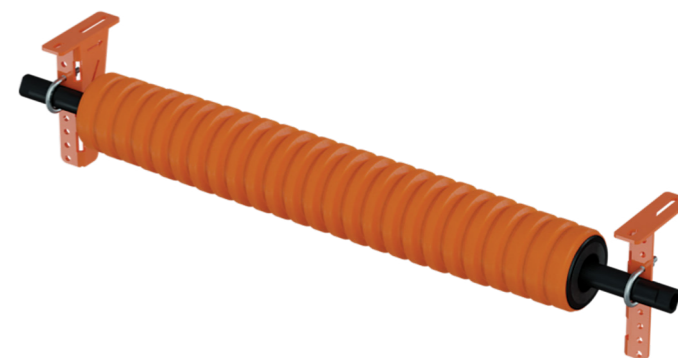



BELT SEALING

Martin Engineering's ApronSeal™ Skirting products are engineered for superior performance in demanding material handling environments. Featuring an innovative dual-sealing design, ApronSeal™ effectively contains airborne dust and mitigates material spillage along conveyor belts. This innovative system requires minimal maintenance and maximises operational efficiency, safeguarding both workers and equipment. Ideal for applications requiring stringent dust control, ApronSeal™ sets a new standard in conveyor belt skirt sealing, delivering unparalleled reliability and performance.



Scan code for more info and resources.

ApronSeal™ Skirting

Martin® ApronSeal™ Skirting provides dual-seal efficiency with a single, one-piece sealing strip for any troughing angle to prevent the escape of fines and dust. The primary seal is clamped to the chute wall with the self-adjusting secondary seal laying outward to create an effective dust seal that is out of the material flow. ApronSeal™ Skirting requires minimal service to maintain an effective seal.

ApronSeal™ Double Skirting uses a patented design that features a reversible elastomer strip to provide a second wear life. Optional quick-release clamps are available. Suitable for application temperatures from -20° to 250°F (-29° to 121°C).

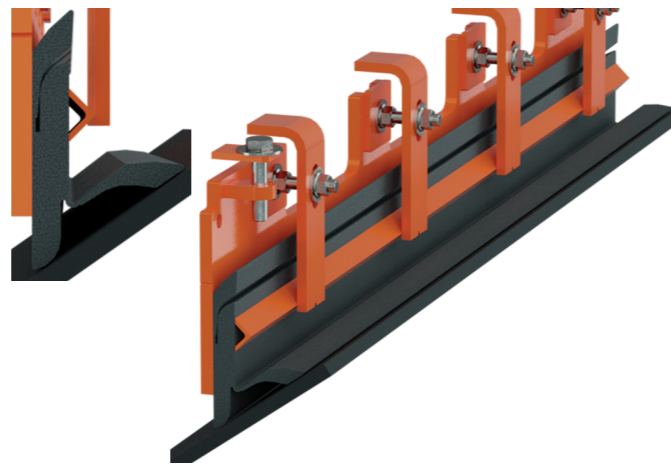

Model	Max Belt Speed fpm (m/s)	Minimum Free Belt Area – in (mm)					
		Trough Angle	Single	Single HD	Single XHD	Double	Double HD
Single	600 (3.0)	0°	2.14 (54)	2.97 (76)	3.50 (89)	2.14 (54)	2.97 (76)
Single HD	750 (3.8)	20°	2.58 (66)	3.74 (95)	4.25 (108)	2.58 (66)	3.74 (95)
Single XHD	750 (3.8)	35°	2.87 (73)	4.18 (106)	4.75 (121)	2.87 (73)	4.18 (106)
Double	600 (3.0)	45°	3.01 (77)	4.38 (111)	5.00 (127)	3.01 (77)	4.38 (111)
Double HD	750 (3.8)						

GravitySeal™ Self-Adjusting Skirting

Martin® GravitySeal™ Self-Adjusting Skirting delivers a reliable skirtboard seal that prevents spillage and reduces issues caused by fugitive material. The system automatically adjusts to maintain an effective seal, eliminating the need for skirtboard maintenance.

Designed for conveyors with minimal free belt edge and featuring a seal and clamp assembly that can be installed in spaces with low clearance to the belt, GravitySeal™ Self-Adjusting Skirting is an ideal choice for tight-fit applications.

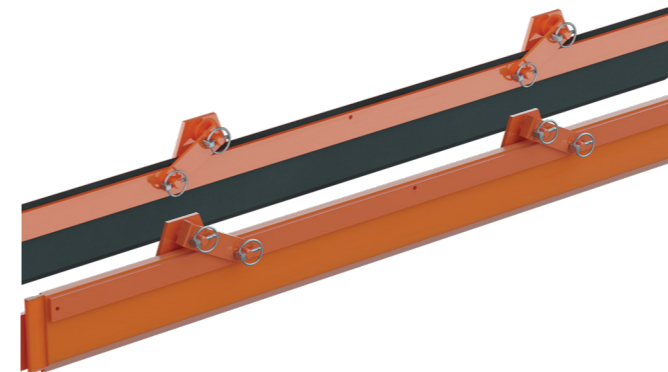

Model	Max Belt Speed fpm (m/s)	Temp Range °F (°C)
Rubber HD	600 (3.0)	-20° to 250° (-29° to 121°)
Urethane HD Max	1300 (6.5)	-40° to 300° (-40° to 149°)

ApronSeal™ Urethane Skirting

Provides reliable containment of material fines with a durable 1-piece or 2-piece seal assembly. The dual-seal system pairs a primary urethane seal with a self-adjusting secondary seal that lays outward to block dust while staying clear of the material flow.

Engineered for minimal maintenance, it performs effectively at belt speeds up to 900 fpm (4.5 m/s) while requiring only two inches (50 mm) of free belt area. The multiple-leg secondary can be trimmed to fit varying belt edges, and the 90-durometer urethane delivers excellent chemical resistance and low abrasion for long service life.

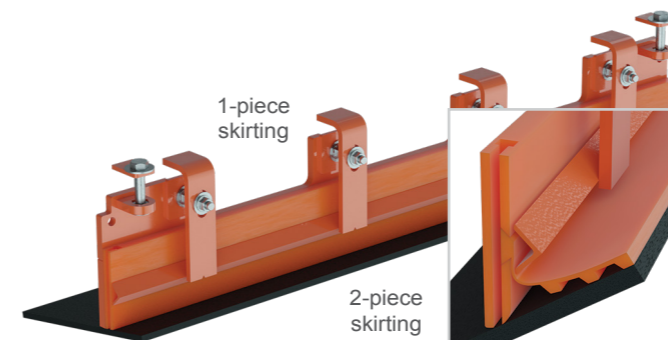

Supplied in 60 in. (1524 mm) strips with convenient T-slot end connections, this skirting is also available in a high-temperature urethane option.

Skirtboard Liner

Installed inside conveyor transfer point skirtboards, Martin® Skirtboard Liners absorb impact and abrasion by creating a dam to shield the sealing system from the weight of the material load, prolonging the life of the seal.

Skirtboard Liners feature a steel plate molded inside the urethane to prevent bond issues. The unique T-slot mounting interface allows the liner to be adjusted from outside the chute wall, eliminating the need for confined space entry. Liners are also stackable to line higher drop chutes.



Trough Angle	Height – in. (mm)	
	1.3 in. (33 mm) thick	2.0 in. (51 mm) thick
20°	6.75 (172)	9.88 (251)
35°	6.75 (172)	10.75 (273)
45°	6.75 (172)	11.50 (292)

External Wear Liner

External Wear Liner is installed on the outside of the chute wall, simplifying wear liner inspection and replacement — both without confined-space entry. Improves liner and skirtboard sealing system performance without adding additional conveyor construction cost. The chute wall can be trimmed to avoid material buildup.

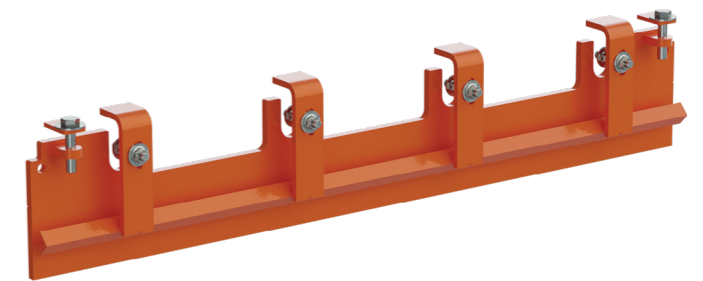

Available in a variety of materials and thicknesses. Fits conveyors with trough angles from flat to 35°. Standard lengths are 48 in. (1219 mm) and 72 in. (1829 mm). Internal Wear Liner also available.



BELT SUPPORT

By providing reliable belt support, especially at transfer points, our products effectively minimise damage and extend the lifespan of your equipment. Martin Engineering's belt support solutions absorb the impact of material falling at transfer points, reducing wear on belts and structures. This proactive approach also prevents belt sag and reduces fugitive material and airborne dust, which pose significant health and safety risks.

Martin Engineering's belt support products are versatile, available for various belt widths, and can be customised to meet specific requirements as needed.



Scan code for more info and resources.

Impact Cradles

Our robust conveyor belt support cradles are engineered to safeguard your conveyor system with unparalleled durability. These cradles ensure stable belt support, effectively preventing damage and minimising airborne dust and material spillage. Ideal for enhancing operational efficiency and safety, our cradles maintain a consistent belt line, reducing maintenance costs and optimising productivity in industrial environments.

Available in standard and wide base.



Model	Belt Width in. (mm)	CEMA Idler Class	Bar Length ft.	Temp Range °F (°C)
Light Duty	24-72 (500-2000)	C5 & C6	4	-20° to 180° (-29° to 82°)
Medium Duty	24-72 (500-2000)	C5, C6, D5, D6	4 or 5	-20° to 180° (-29° to 82°)
Trac-Mount™	24-96 (500-2400)	C5, C6, D5, D6	4	-20° to 180° (-29° to 82°)
Heavy Duty	36-72 (800-2000)	E6 & E7	2	-20° to 140° (-29° to 60°)



Visit Martin Engineering's official **Sketchfab** site to view interactive 3D visualisations of our entire portfolio of products, offering a unique and immersive digital experience in which to explore key products features and construction. >> sketchfab.com/martinengineering

High Speed Impact Cradle

Designed and engineered for high speed / high tonnage belts, Martin® High Speed Impact Cradles provide belt support in transfer points where belt speeds exceed the operating limits of ordinary impact bar belt support cradles.

Innovative patent-pending upper connector brackets link idlers together throughout the load zone, allowing them to work together as a unified structure. Elastomer bar suspension absorbs shock from impact, maximising the life of the belt support structure and rolling component while Trac-Mount™ Idler design (see following page) provides ease of service.

Idler Diameter in. (mm)	CEMA Idler Class	Belt Width in. (mm)	Max Belt Speed fpm (m/s)
5 (127)	D5, D6	30-72 (760-1800)	700 (3.5)
5 (127)	E6, E7	36-96 (900-2400)	700 (3.5)
6 (152)	D5, D6	30-72 (760-1800)	870 (4.4)
6 (152)	E6, E7	36-96 (900-2400)	870 (4.4)
7 (178)	D5, D6	30-72 (760-1800)	870 (4.4)
7 (178)	E6, E7	36-96 (900-2400)	870 (4.4)



Visit our online **Foundations™ Learning Centre** for free articles, videos, e-books, and blog posts offering a variety of information including selection guides, maintenance checklists, troubleshooting tips and tricks, and much more. >> foundations.martin-eng.com/en/knowledge

Combination Cradle

Centre bars are set slightly below the unloaded belt's line of travel to absorb impact while avoiding continuous friction and wear if the belt is running empty. The wing bars on the sides of the cradle are installed in line with the idlers to allow effective sealing of the transfer point. Eccentrics in wing supports allow outer bars five degrees of wear adjustment. Impact bars are each secured with two bolts making replacement simple.

Optional centre rolls reduce friction and require less conveyor drive horsepower than bars.



Belt Width in. (mm)	Max Belt Speed fpm (m/s)	CEMA Idler Class	Bar Length ft	Temp Range °F (°C)
24-72 (500-2000)	1000 (5.0)	C5, C6, D5, D6	2	-20° to 160° (-29° to 70°)



Visit our **On-Demand Webinar Library** for dozens of free on-demand video recordings covering a wide variety of topics including belt conveyor optimisation, carryback and belt cleaning, material flow, dust control, and safety and culture. >> foundations.martin-eng.com/webinars-on-demand

Slider Cradle

Installed under the skirtboard of a transfer point, Martin® Slider Cradles support the edges of the belt to eliminate sag. These cradles prevent transfer point spillage by stabilising the belt's path and allow effective sealing of the belt edge. Cradles are available with single or double adjustable high-performance UHMW or Stainless Steel Bars to match application requirements.



Belt Width in. (mm)	Max Belt Speed fpm (m/s)	Bar Length ft	Temp Range °F (°C)
18-42 (450-1100)	500 (2.5)	4	-20° to 140 (-29° to 60°)
48-96 (1200-2400)	700 (3.5)	4	-20° to 140 (-29° to 60°)



Visit our website to download our **Foundations™ Books**, industry-standard textbooks for cleaner, safer, and more productive conveyor operation and maintenance, along with e-books covering a variety of specific bulk material handling and material flow topics. >> foundations.martin-eng.com/book-options

Trac-Mount™ Idlers

Trac-Mount™ Idlers utilise sliding frames on a stationary base to provide an idler set that will fit in tight spaces between belt support cradles and allow easy installation and service. Available with standard or wide base frames and utilise either impact or steel rolls in CEMA class C, D, or E on belt widths 18-96 inches (450-2400 mm).



Slide-out/slide-in roller frames allows idler service without need to raise belt or remove adjacent idlers.

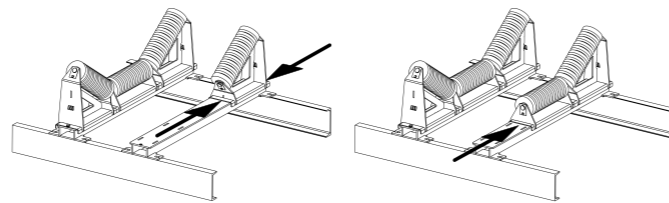

Return Roller

The Martin® Return Roller is a pivoting track-mounted return idler that allows for safe, quick, and simple one-sided serviceability and roll replacement.

Three-piece hanger frame adjusts to accommodate different belt widths from 24-72 inches (500-2000 mm). Universal bracket fits most major idler manufacturers' idlers and sizes.



DUST MANAGEMENT

In bulk material handling operations, one of the most significant sources of dust is the belt conveyor transfer point. Dust is generated as bulk material is transferred from one belt to another. When material is in free fall, it is exposed to significant airflow. This airflow, with enough velocity, carries dust until it slows and settles.

The most effective approach to reducing dust at conveyor load zones is to eliminate dust at the source.



Scan code for more info and resources.

Air Cleaner

To overcome the maintenance problems and operating costs of centralised dust control systems, Martin Engineering recommends the use of a Martin® Air Cleaner on conveyor transfer points. Rather than carry dust-laden air to a central collector, insertable systems filter the air locally. There is no large fan, no ductwork, and no central bag house. Insertable filters are integrated into the transfer point enclosure where they can easily return material to the conveying system.

Removes 99.9% by weight of all dry particulate one micron and larger. Effectively handles the heavy concentrations of dust and high volumes of air arising at belt conveyor transfer points.



Dust Bag

A Dust Bag is a passive dust collection system installed above the loading zone to capture dust without an energy-consuming fan. When loading stops, the bag relaxes to return material to the belt. Satin nylon construction withstands positive pressure. Both standard and static-dissipating options are available.

Bag Size in. (mm)	Airflow cfm (l/minute)
12 (300)	Up to 450 (12,750)
24 (600)	Greater than 450 (12,750)





CONVEYOR LOAD ZONE CONTAINMENT

Transfer Point Kits include modular load zone, settling zone, and stilling zone configurations, providing easier installation and a wider variety of chute options while facilitating future upgrades. The kit simplifies the installation process, reducing the amount of labor required for assembly and allowing the system to be pre-built prior to installation for reduced system downtime. The result is faster installation with less labor and shorter shutdowns, increasing the return on investment (ROI).



Scan code for more info and resources.

A.I.R. Control™ Dust Curtains

The A.I.R. Control™ Dust Curtain is an adjustable, replaceable dust-control solution engineered for conveyor transfer points handling bulk materials. Its modular urethane curtain elements can be individually adjusted or replaced from outside the enclosure, eliminating confined-space entry and reducing service time to just minutes.

By positioning narrower-than-enclosure curtain arrays close to the material load, the A.I.R. Control™ Dust Curtain creates controlled recirculation zones that significantly reduce passive dust emissions—achieving up to 90% reduction in respirable and nuisance dust compared to conventional slit-rubber curtains.

Designed for both passive and active dust-control applications, the system improves sealing, lowers air exit velocity, and enhances overall transfer-point performance while reducing maintenance labor and cost.

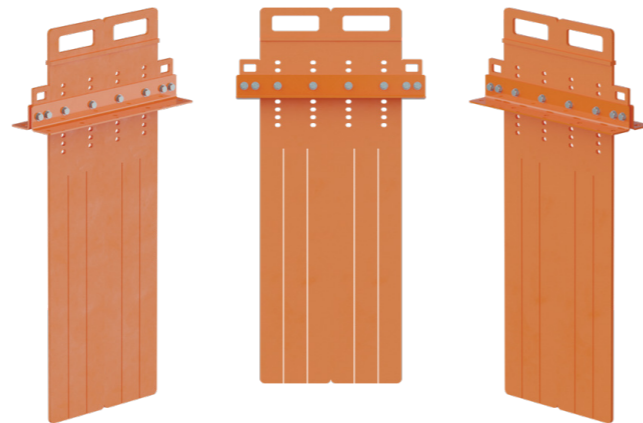

Visit Martin Engineering's official **Sketchfab** site to view interactive 3D visualisations of our entire portfolio of products, offering a unique and immersive digital experience in which to explore key products features and construction. >> sketchfab.com/martinengineering

Transfer Point Kits

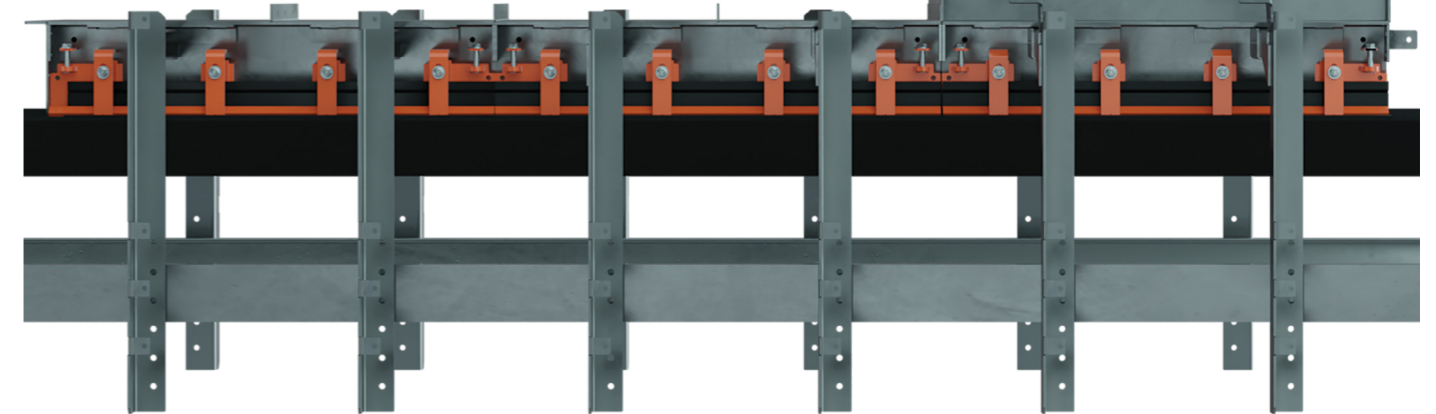

Load Zone

Settling Zone

Stilling Zone

Each kit is delivered in a single package with every component for assembly included. The kits are able to be assembled prior to shutdown and installation, saving time and money. The kits are also fully modular, making future changes easy without expensive construction projects.

Each kit is either ordered as a load zone, settling zone, or stilling zone. The width and length of the kit are determined by the receiving belt's width and speed and the dust characteristics of the material being transferred. Dusty applications may require a longer settling zone.

Component	Load Zone	Settling Zone	Stilling Zone
Chute Wall Weldment	X	X	X
External Wearliner Assembly	X	X	X
Outer Chute Supports	X	X	X
ApronSeal™ Clamps	X	X	X
Owner's Manual	X	X	X
Installation Hardware	X	X	X
Dust Curtains		X	X
Inner Chute Wall Supports		X	X
Internal Wear Liner	X		
Tail Panel, Clamp, & Rubber Sheet	X		



Kits are also available to construct a tailbox.

Skirt seal is sold separately as a single piece that runs the entire length of the loading and settling zones.



>> See page 20 for our full range of sealing solutions.

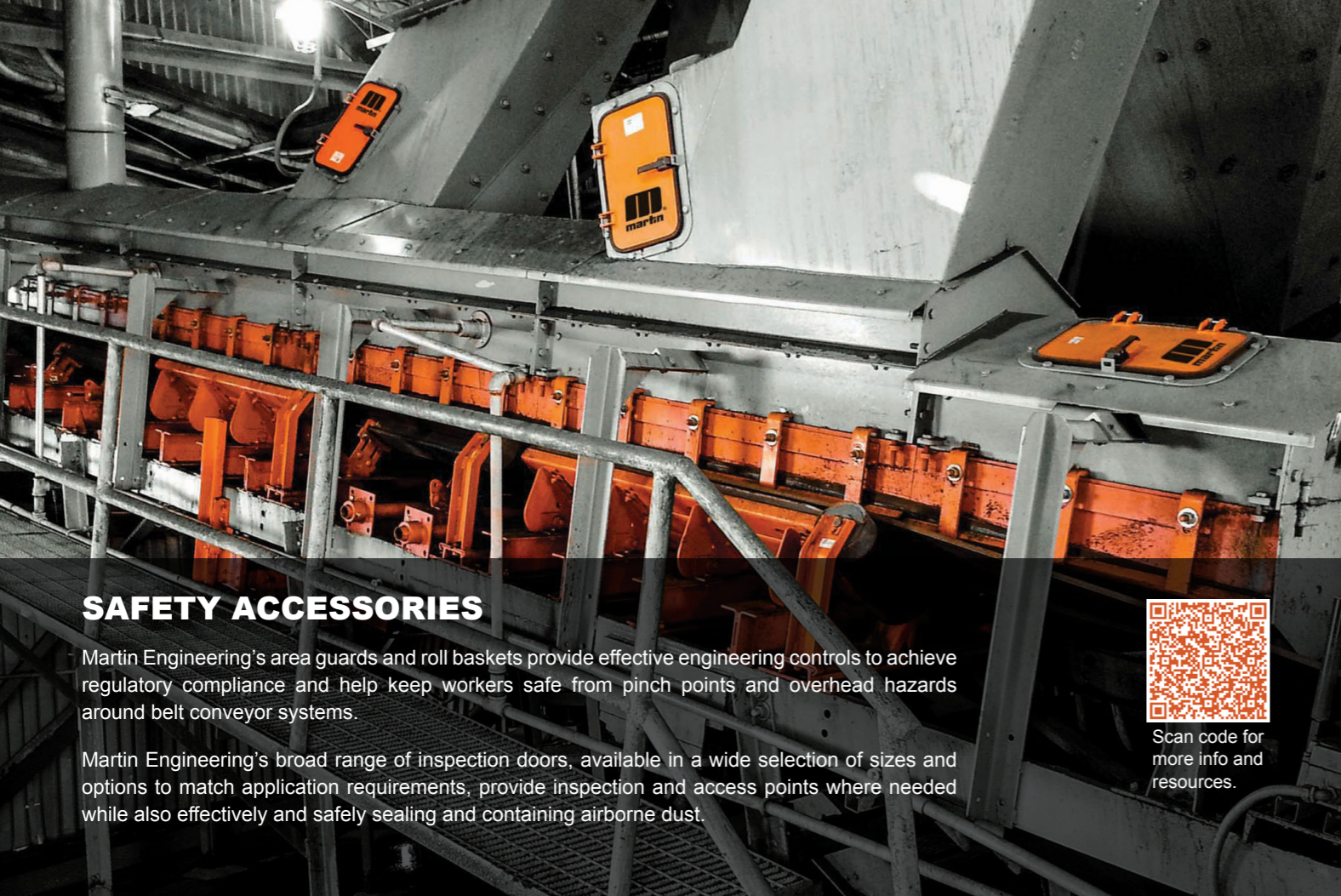

SAFETY ACCESSORIES

Martin Engineering's area guards and roll baskets provide effective engineering controls to achieve regulatory compliance and help keep workers safe from pinch points and overhead hazards around belt conveyor systems.

Martin Engineering's broad range of inspection doors, available in a wide selection of sizes and options to match application requirements, provide inspection and access points where needed while also effectively and safely sealing and containing airborne dust.



Scan code for more info and resources.

Inspection Doors



The Martin® Inspection Door is dust-tight and allows inspection and access in chutes and other enclosures for belt cleaner maintenance or other service requirements.

The sturdy, low-profile design features a dust-tight rubber seal and can withstand typical positive and negative pressure applications. Simple installation allows doors to either be bolted or welded to the enclosure wall. Doors are also available with an internal guard screen to restrict access and prevent workers from breaking the plane.

Doors available in painted steel, 304 or 316 stainless steel, or rubber. Optional features such as lockable latches, AR500 internal wear liners, and high-temperature seals are also available.



  >> Watch a video about Martin® Inspection Doors.

  Visit Martin Engineering's official **YouTube channel** to view a selection of hundreds of long- and short-form videos offering a range of content from expert insights and webinar excerpts to product highlights and case studies, and much more. >> youtube.com/@martinengineering

Conveyor Guard

Martin Engineering's mesh panel guards conform to OSHA and MSHA (USA) standards and prevent worker exposure to conveyor nip points and pinch point hazards.

Laser cut panels don't present the opportunity for broken welds or sharp edges commonly seen with expanded metal guards while rugged 11 gauge steel provides greater strength, durability, and reliability than lighter-weight metals and plastic. Guards are also available in 304 stainless steel.

Single or double wedge clamps allow panels to be removed and reinstalled quickly and the modular design installs on supplied angle iron structure without attaching to conveyor equipment. Wedge bolts are also available.

Guards are available in several sizes and colors and can be used in a variety of combinations to fit almost any application. Systems can be easily expanded or relocated as needed.



Return Roller Guard

The Martin® Return Roller Guard features quick release pins which allow access to the grease fittings within the return roller without the need to remove the guard.



Lightweight metal construction bolts directly to either the side or bottom of the stringer for easy installation with no additional bolts required for assembly. Fits all major roll manufacturers' sizes.

Riveted pins are accessible from both sides and bottom and allow the guard to open quickly and safely for maintenance. Removable end plates provide access to roller bearings.

Return Roller Basket

The Martin® Return Roller Basket is designed to prevent a return roller from falling in case of mechanical failure. Solid steel construction covers all major return roller manufacturers.

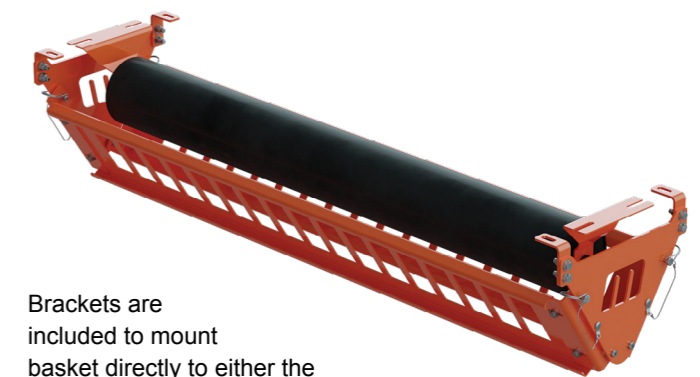

Brackets are included to mount basket directly to either the side or bottom of the stringer and quick-release pins allow easy access.



Open design prevents material buildup in basket while allowing inspection. Baskets are designed to fit all major roll manufacturers' sizes (CEMA B, C, D, & E).

Magnetic Urethane Chute Patch

The Magnetic Urethane Chute Patch is a quick and easy way to repair a hole worn into a chute to prevent material from leaking until a permanent repair can be made. This patch can also be used inside the chute to prevent wear. High-strength embedded magnets securely hold the patch in place, eliminating the need for welding and can easily be removed or repositioned if necessary.

Available in 6x6-inch and 12x12-inch sizes.



  Visit our **On-Demand Webinar Library** for dozens of free on-demand video recordings covering a wide variety of topics including belt conveyor optimisation, carryback and belt cleaning, material flow, dust control, and safety and culture. >> foundations.martin-eng.com/webinars-on-demand



AIR CANNONS

Martin Engineering's air cannons apply precisely timed bursts of compressed air to prevent material buildup on interior container walls and obstructions at discharge ports.

Ensuring proper material flow and mitigating buildup avoids unplanned downtime, lost production, and the time and hazards involved with manual cleaning while helping maximise designed production capacity.



Scan code for more info and resources.

Hurricane Air Cannon

The Hurricane Air Cannon features an advanced positive pressure, positive firing valve concept that provides more force, uses less air, and simplifies installation and maintenance.

Highly effective discharge strength from high velocity output requires half the air volume of standard air cannons, reducing operating costs.

The complete valve assembly can be removed in one easy step, working from one side of the tank. It can be replaced within minutes to keep your process running. There is no need to ever remove the tank from the vessel for service.

Positive-acting valve eliminates the risk of an accidental discharge while allowing the control solenoid to be positioned as far as 200 feet (60 m) from the tank, keeping solenoids away from harsh conditions and difficult-to-service areas.

Available with 35, 70, and 150L tanks.



Visit Martin Engineering's official **Sketchfab** site to view interactive 3D visualisations of our entire portfolio of products, offering a unique and immersive digital experience in which to explore key products features and construction. >> sketchfab.com/martinengineering

Typhoon Air Cannon

The Typhoon Air Cannon features a hybrid valve concept that provides more force, uses less air, and simplifies maintenance in challenging applications with limited budgets.

Highly effective discharge strength from high velocity output requires half the air volume of standard air cannons, reducing operating costs.

The complete valve assembly can be removed in one easy step, working from one side of the tank. It can be replaced within minutes to keep your process running. There is no need to ever remove the tank from the vessel for service.

Negative pressure firing provides effective performance in challenging applications with limited budgets. Upgrades existing older technology air cannons using normally-open solenoids without the need for replumbing the system.

Available with 35, 70, and 150L tanks.



Tornado Air Cannon

The Tornado Air Cannon produces better material flow with greater force, faster cycling, and improved safety, firing when the exhaust valve opens in response to a positive surge of air sent by a tripped solenoid valve.

Available with a 2-inch discharge in two tank sizes, with a retrofit valve also available, the Tornado Air Cannon is a versatile solution suitable for smaller applications.



Passport Air Cannon

The Passport Air Cannon features traditional externally-mounted valves while offering both negative and positive firing options to maintain proper material flow, eliminating manual cleaning and unplanned downtime and ensuring maximum design capacity and throughput.

Available with either Hurricane or Typhoon valves.



N2® Air Cannon Intelligence System

The N2® Air Cannon Intelligence System delivers real-time monitoring of every cannon on your line, detecting misfires, measuring blast efficiency, and tracking pressure and temperature to spot issues before they impact production. A rugged sensor and cellular gateway feed data to a cloud dashboard, giving you instant visibility into system health, performance trends, and alerts—turning air-cannon maintenance from reactive to predictive while reducing manual inspections and improving safety.



Visit Martin Engineering's official **YouTube** channel to view a selection of hundreds of long- and short-form videos offering a range of content from expert insights and webinar excerpts to product highlights and case studies, and much more. >> youtube.com/@martinengineering

Blow Pipes

This simple pipe solution can be installed at 90 degrees or any custom angle to suit your needs. It comes in mild steel for ambient applications and stainless steel for high-temperature environments. Reliable, versatile, and designed to meet various industrial requirements.

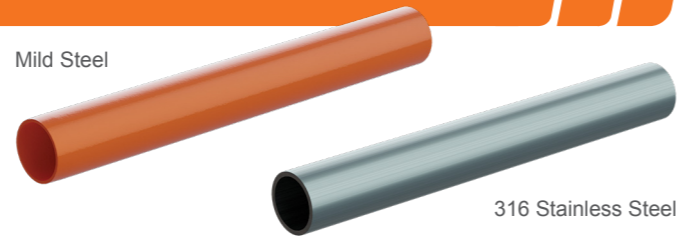

Visit our online **Foundations™ Learning Centre** for free articles, videos, e-books, and blog posts offering a variety of information including selection guides, maintenance checklists, troubleshooting tips and tricks, and much more. >> foundations.martin-eng.com/en/knowledge

SMART™ Series Nozzles

The innovative design of SMART™ Series Nozzles eliminates damage to refractory and makes it possible to maintain nozzles without removing air cannons.

Eliminates improper alignment and the time and cost of cutting holes and breaking refractory to replace worn out nozzles. Replacement is quick and easy; no entry required into the tower or cooler and no need to remove the air cannon tank.

Provides a wider area of influence than a standard fan nozzle. Available in straight or “Y” pipe arrangement.

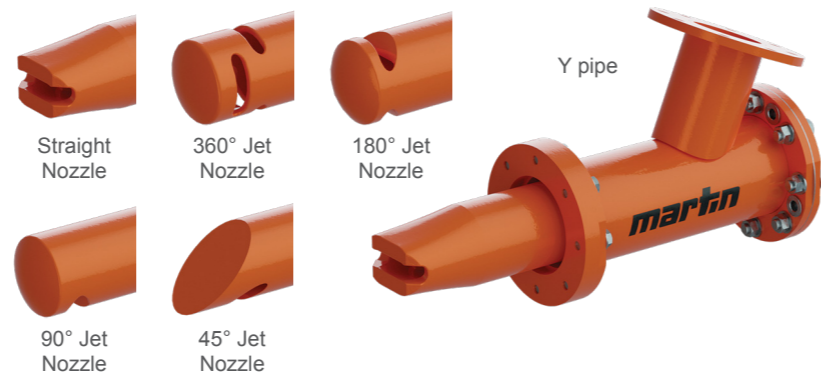

SMART™ Series Retractable Nozzle 360°

The SMART™ Series Retractable Nozzle 360° extends service life in preheater towers and high-temperature/high-dust applications by pulling the discharge inside the vessel.

The nozzle extends to fire then retracts to protect the exposed tip from extreme heat. Provides 360° of effective cleaning area, making cleaning the centre of the wall possible.

Serviceable from the outside of the riser duct, nozzle assembly replacements don't have to wait until the next scheduled outage.



Works with standard air cannons and is controlled by a single solenoid.

Thermo Safety Shield

The Thermo Safety Shield is a slide gate that bolts between an air cannon valve and mounting flange, acting as a safety barrier to allow timely and safe maintenance of air cannon systems. It protects employees from exposure to severe heat, gases, and high temperature material so that maintenance takes place safely and production stays on schedule. The sliding shield operates under tough conditions, yet can be locked out to prevent intrusion.

Available for any air cannon with 4-inch discharge.



Nozzles

Ideal for cleaning flat surfaces on ductwork, chutes, rock boxes, precipitators, and SCRs. They are versatile and can be used wherever material needs to be reintroduced into the process. The design ensures efficient cleaning and material flow. Ideal for maintaining operational efficiency in various industrial settings.

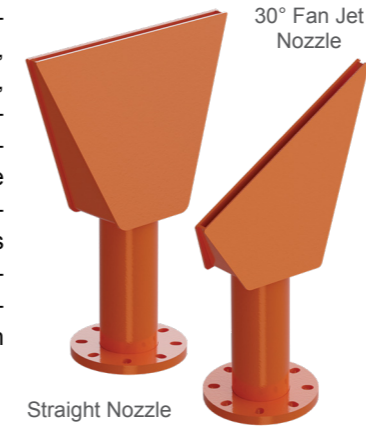

Mount Plates

Ideal for use on bins, hoppers, and silos. The 30-degree angle efficiently directs flow toward the outlet of standard vessels. The Drop Thru version is specifically designed to penetrate liners such as stainless steel or wear plates. This ensures smooth material flow and prevents blockages.

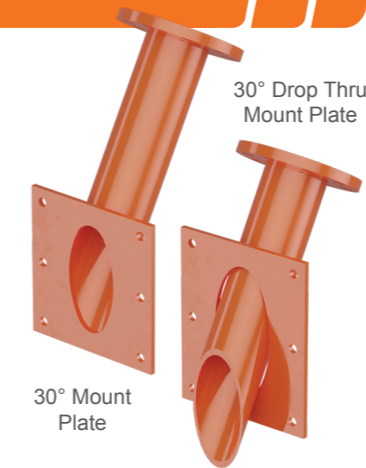

Scan QR code for additional information and resources for air cannon nozzles, blow pipes, and mount plates.

Six Pack Program

Martin Engineering offers a “6 pack” of refurbished Hurricane or Typhoon replacement valves to stock on your shelf. Guaranteed against defects, refurbished valves carry the full factory warranty.

Comes in a standard pallet-sized container to refill with worn-out valves and send back to Martin Engineering to be refilled with refurbished valves and returned to you.

Only one part to stock in your warehouse. 40% lower cost compared to purchasing six individual valves. Eliminates purchasing repair kits & the labor to rebuild them.

Air Cannon Controller

Energizes solenoid valves to control the automatic sequencing and discharge for a system of up to ten

Martin® Air Cannons.

Firing schedule adjustable from one second to 18 hours. Remote dry contact allows timer to be actuated by motor control, flow switch, or manual switch. Available as single circuit and multiple circuit units.



Air Cannon X-Stand

The X-Stand is the perfect solution for mounting your air cannon in challenging environments. Designed to fit 35L, 70L, and 150L air cannons, it allows you to position cannons outside high-heat areas or in smaller, hard-to-reach spaces.

Stackable both horizontally and vertically, the X-Stand keeps the cannon safely out of the way, providing easy access to your vessel's walls for maintenance and inspection. Durable and versatile, it's the ideal mount for optimising your air cannon's performance.

Retrofits existing Hurricane and Typhoon models.

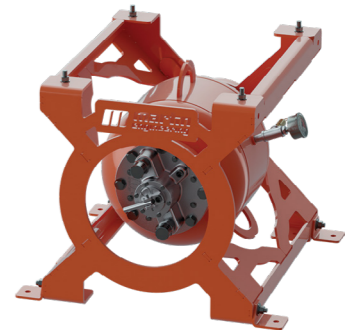

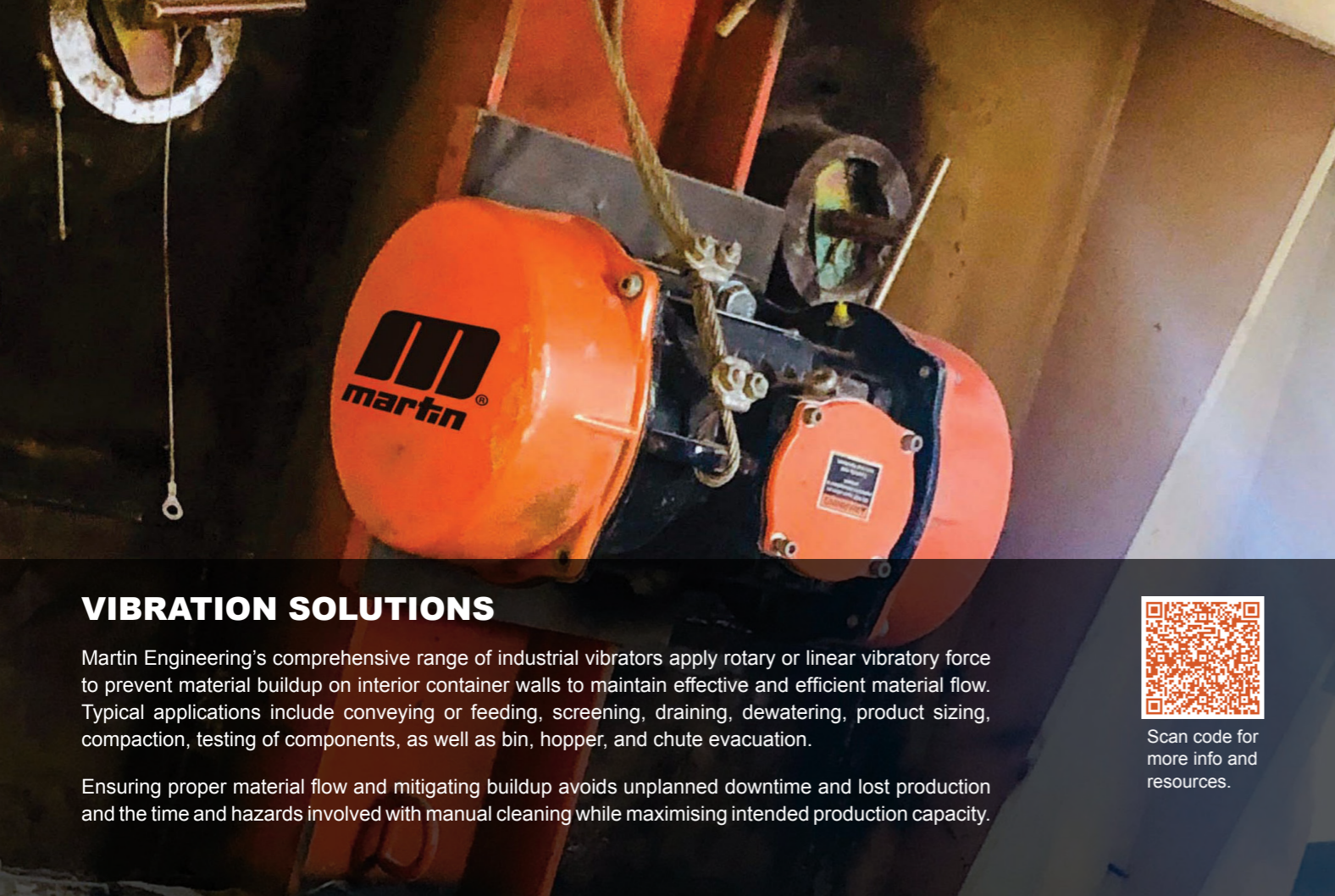

VIBRATION SOLUTIONS

Martin Engineering's comprehensive range of industrial vibrators apply rotary or linear vibratory force to prevent material buildup on interior container walls to maintain effective and efficient material flow. Typical applications include conveying or feeding, screening, draining, dewatering, product sizing, compaction, testing of components, as well as bin, hopper, and chute evacuation.

Ensuring proper material flow and mitigating buildup avoids unplanned downtime and lost production and the time and hazards involved with manual cleaning while maximising intended production capacity.



Scan code for more info and resources.

Ball Vibrators

Powered by compressed air, these long-lasting ball vibrators contain a chrome ball bearing that spins along a circular track inside the housing. The rapid rotational movement of the ball bearing applies centrifugal force to the casing, causing it to vibrate. Ball vibrators are an economical vibration solution that contains only one moving part, which means they require zero ongoing maintenance.

Available in a wide range of sizes, porting, and mounting options, ball vibrators deliver a high ratio of force relative to their weight, so they are powerful enough for large jobs such as eliminating material blockages from rigid bins, chutes, and hoppers. They are also ideal for small jobs such as moving small parts in assembly processes.

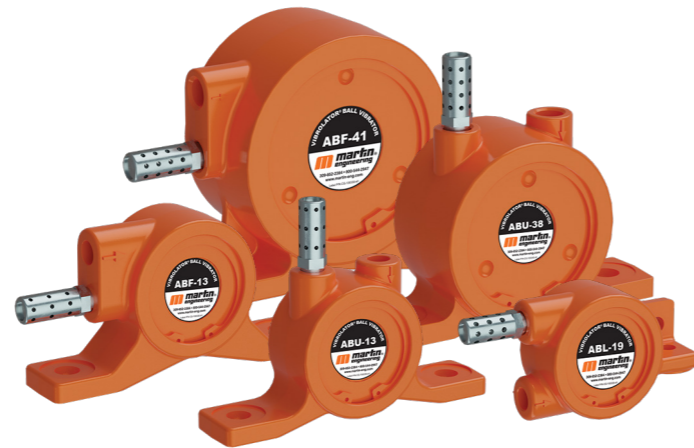

Visit our **On-Demand Webinar Library** for dozens of free on-demand video recordings covering a wide variety of topics including belt conveyor optimisation, carryback and belt cleaning, material flow, dust control, and safety and culture. >> foundations.martin-eng.com/webinars-on-demand

Roller Vibrators

Martin Engineering's long-lasting roller vibrators contain a steel, ring-shaped roller that spins around a steel shaft, powered by compressed air. The rapid rotational movement of the roller produces multiple vibrations with each rotation. Roller vibrators are an economical vibration solution for applications that require high force-to-weight ratios.



Available in a variety of sizes and strengths, roller vibrators deliver a high level of vibratory force and are ideal for unloading railcars and compacting both concrete and refractory. Roller vibrators are the only pneumatic option that delivers both high frequency and high amplitude. The rugged epoxy-coated cast design makes them perfect for continuous operation, even in dusty, wet, and harsh environments.

Vibrator™ CCR Vibrator

This simple, long-lasting portable pneumatic vibrator provides effective high-frequency vibration at an economical price. Apply to railcars, chutes, screens, and compaction tables to prevent material buildup.

Generates multiple vibrations on each orbit while bearing-free design eliminates wear problems and extends service life.



Mount options include weldable cradle-lug bracket, cradle-lug wedge bracket, or cradle-lug clamp mount.



Visit our website to download our **Foundations™ Books**, industry-standard textbooks for cleaner, safer, and more productive conveyor operation and maintenance, along with e-books covering a variety of specific bulk material handling and material flow topics. >> foundations.martin-eng.com/book-options

Turbine Vibrators

Martin Engineering's pneumatic turbine vibrators contain an unbalanced turbine wheel that spins inside the casing. The rapid, unbalanced rotational movement of the turbine applies centrifugal force to the casing, producing the vibratory force. These vibrators use very little compressed air relative to the force they deliver, so the long-term cost of ownership is low.

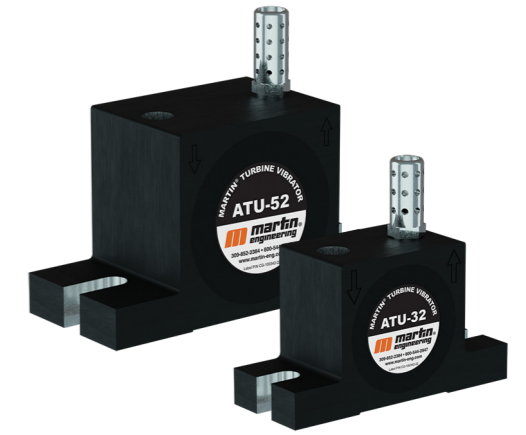

Turbine vibrators produce noise levels well below OSHA (USA) requirements, so they are an effective solution for noise-sensitive areas. They are ideal for applications such as portioning ingredients in food processing plants and feeding small parts made of plastic or metal onto a feeding tray, as well as conveying materials or loose items in the chemical and pharmaceutical industries.

Whirlwind High-Frequency Vibrator

Great for concrete consolidation and railcar unloading, the Whirlwind High-Frequency Turbine Vibrator is a urethane-encapsulated vibrator that mounts easily with cradle lug brackets.



Larger unbalance creates greater force output to move your material while long-life, high-speed sealed bearings need no lubrication.

AP5 Series Piston Vibrators

An economical solution to eliminate the pounding, poking, and hammering of hoppers, the AP5 Series Piston Vibrators help maintain material flow and reduce bottlenecks.

Limited maintenance required for life of the vibrator when used with filtered and lubricated air supply.

Variable control of force and frequency to meet a variety of material conditions.

Can be a bolt-in direct replacement for nearly all piston vibrators on the market.

Comes standard with exhaust mufflers to attenuate the exhaust noise and aid in preventing dust and dirt from entering the vibrator.



Visit Martin Engineering's official **YouTube channel** to view a selection of hundreds of long- and short-form videos offering a range of content from expert insights and webinar excerpts to product highlights and case studies, and much more. >> youtube.com/@martinengineering

PV Series Piston Vibrators

PV Piston Vibrators deliver powerful linear force to keep stubborn materials flowing from bins, hoppers, chutes, and railcars. Five sizes available to suit material, storage system, and air supply. Use with permanent or portable mounts.

For increased durability, consider the Lempcoloy sleeve option for longer working life in severe-duty applications like high-temp environments and continuous operation. Once worn, just replace the sleeve instead of the entire vibrator assembly.



Visit Martin Engineering's official **Sketchfab site** to view interactive 3D visualisations of our entire portfolio of products, offering a unique and immersive digital experience in which to explore key products features and construction. >> sketchfab.com/martinengineering

Thumper™ Timed Impactors

Thumper™ Series Timed Impactors deliver powerful blows at controlled intervals, producing a sledge hammer effect without hopper damage or manual labor.

This pneumatic impactor is controlled by a timer to deliver powerful industrial vibration to keep production flowing and reduce material buildups.

Controls noise and prevents vessel damage while handling heavy work loads with limited air supply. Optional timers control the number of blows per minute.

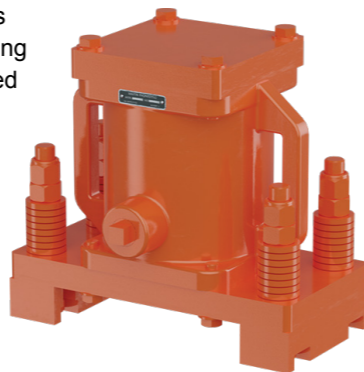

2000 Series Piston Vibrators

The 2000 Series Piston Vibrator provides high frequency and high impact energy to reduce bottlenecks and material buildups. Alloy steel bodies with hardened pistons require low air consumption to produce uniform directional force.

Options include internal spring for positive starting, manifold/muffler for quiet operation, air cushioning for non-impacting operation, universal mount, and high-temperature models for applications up to 400°F.

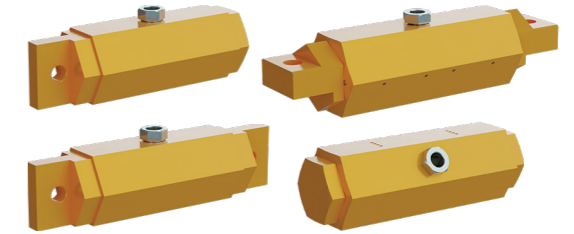

Visit our online **Foundations™ Learning Centre** for free articles, videos, e-books, and blog posts offering a variety of information including selection guides, maintenance checklists, troubleshooting tips and tricks, and much more. >> foundations.martin-eng.com/en/knowledge

Brute® Vibrators

Brute® Vibrators are equipped with motor-driven rotary eccentric weights that can be powered by a hydraulic or pneumatic motor and deliver rotary vibration through a complete range of frequencies. The motor is attached to the separate head or case assembly containing the eccentric weights, bearings, and shaft.

Powerful, efficient motor for long service life with minimal power consumption and high-grade ductile iron case to provide maximum durability.

Adjustable eccentrics allow tuning of force output of most models to match application and a tapped exhaust port allows muffler installation to reduce operating noise.

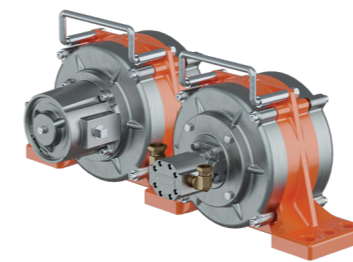

DV Series

For permanent installation on large vessels, these vibrators come with four- or six-bolt-hole mount bases.

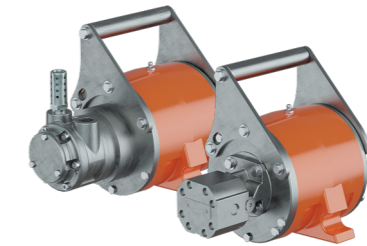

CC Series

With its cradle lug bracket, the CC Series is suited for applications requiring portability and position changes.

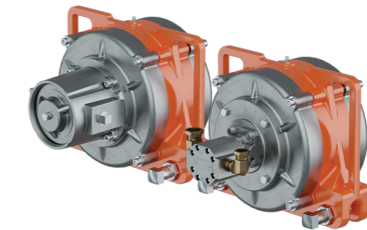

CCV Series

With an integral clamp foot, these powerful vibrators suit portable applications like railcar unloading.



CV Series

CV Series Vibrators incorporate two bolt-holes for permanent mounting on hoppers, bins, or chutes.



Visit our **On-Demand Webinar Library** for dozens of free on-demand video recordings covering a wide variety of topics including belt conveyor optimisation, carryback and belt cleaning, material flow, dust control, and safety and culture. >> foundations.martin-eng.com/webinars-on-demand

MM & MC Series Electric Vibrators

Martin Engineering supplies the only USA-manufactured continuous-duty, high-output/low-frequency industrial vibrators guaranteed for 3 years.

MM and MC Series Electric Vibrators are engineered for continuous duty and feature C4 clearance roller bearings. Dust-tight, water-tight, O-ring seals and machined surfaces provide an IP 66 enclosure rating to protect against the entry of dust and water.

Drives are fully interchangeable with other major manufacturers.



Vertical Electric Vibrators

Martin Engineering MFS and MFD Series vibrators are typically used in medium and large sieves and circular screens. They are rated at 1/3, 1/2, and 2 1/2 hp and are capable of producing forces up to 4,535 kgs.

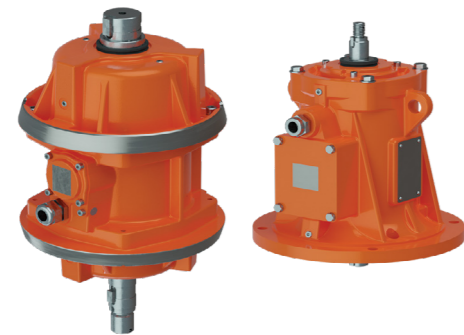

Manufactured in the Australia, models are available in any electrical rating, inverter-duty rated, and guaranteed for 3 years.

Single-flanged MFS Series models are suitable for 609 mm and 762 mm separators. Double-flanged MFD Series models are suitable for 1,219.2 mm and 1,524 mm separators.

Electric Screen Vibrators

Martin® Screen Vibrators are the preferred replacement for Derrick® shaker motors and are designed to serve as a direct retrofit for Derrick® shaker screens, requiring no modifications or adapters. Sturdy construction is designed for long performance life and serviceability and carries an industry-leading 3-year warranty.

Units provide up to 7,484 kilograms of centrifugal force and high-strength cast aluminum cases are IP 66 dust-tight/water-tight. Low-maintenance units require only periodic lubrication of the long-life cylindrical roller bearings. Provided with adjustable eccentric weights to match specific performance requirements. Explosion-proof models bear the ETL, cETL, ATEX, and IECex marks for use in hazardous locations.



Hydraulic Screen Vibrators

Hydraulic Screen Vibrator provides efficient power to sort or separate material. These units offer improved pricing, delivery from stock, and an unmatched 3-year warranty.



This industrial vibrator provides hydraulic vibration for efficient material separation on screen and compaction tables or portable screen applications where no electricity is available.

Units provide up to 3,764 kilograms of centrifugal force. Only service required is bearing lubrication with a grease gun every 2,000 operating hours. Utilises the same mounting bolt patterns as electric vibrators.

Cougar® DC Truck Vibrators

Rugged and economical, Cougar® DC Truck Vibrators provide power to improve the speed and efficiency of unloading dump trucks, concrete pumps, fertiliser, gravel, sand and salt-spreaders, and other mobile equipment. Models are available to suit your truck and your typical load.

Weather-proof aluminum housing provides high output to weight ratio, delivering up to 1,678 kilograms of vibratory force to improve the unloading of wet, sticky, fibrous, or even frozen material. Small, lightweight units require minimal space while sealed ball bearings eliminate lubrication requirements.

Choose from 12- or 24-volt motor; models match force to output requirements. Supplied with mounting hardware and electrical connections.



Cougar® MDC Truck Vibrators

Available with weights set at either 181 or 317 kilograms of vibratory force to improve the unloading of wet, sticky, fibrous, or even frozen material. New high-efficiency motor design with oversized permanent magnet requires less current to operate, putting less stress on your electrical system and allowing the vibrator to run cooler.

O-ring seals and machined surfaces provide protection against the entry of water and dust for an IP 66 rating while smooth external surfaces eliminate material buildup. Small, lightweight units require minimal space while sealed ball bearings eliminate lubrication requirements.

Choose from 12- or 24-volt motor; models match force to output requirements. Supplied with mounting hardware and electrical connections.



Cougar® SDC Truck Vibrators

Cougar® SDC Small Truck Vibrators deliver from 18 up to 90 kilograms of vibratory force to improve the unloading of wet, sticky, fibrous, or even frozen material.



Weather-proof and corrosion resistant nylon housing provides high-output-to-weight ratio. Features 12-volt motor and permanently lubricated sealed ball bearings.

THD Hydraulic Vibrators

Built from high-strength aluminum for maximum durability. Efficient motor designed for minimal power consumption and maintenance requirements. Designed to create more force per size/weight. Provides variable speed and continuous duty operation.

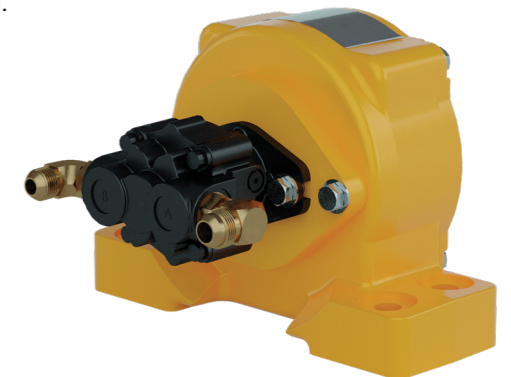

Visit Martin Engineering's official **Sketchfab** site to view interactive 3D visualisations of our entire portfolio of products, offering a unique and immersive digital experience in which to explore key products features and construction. >> sketchfab.com/martinengineering

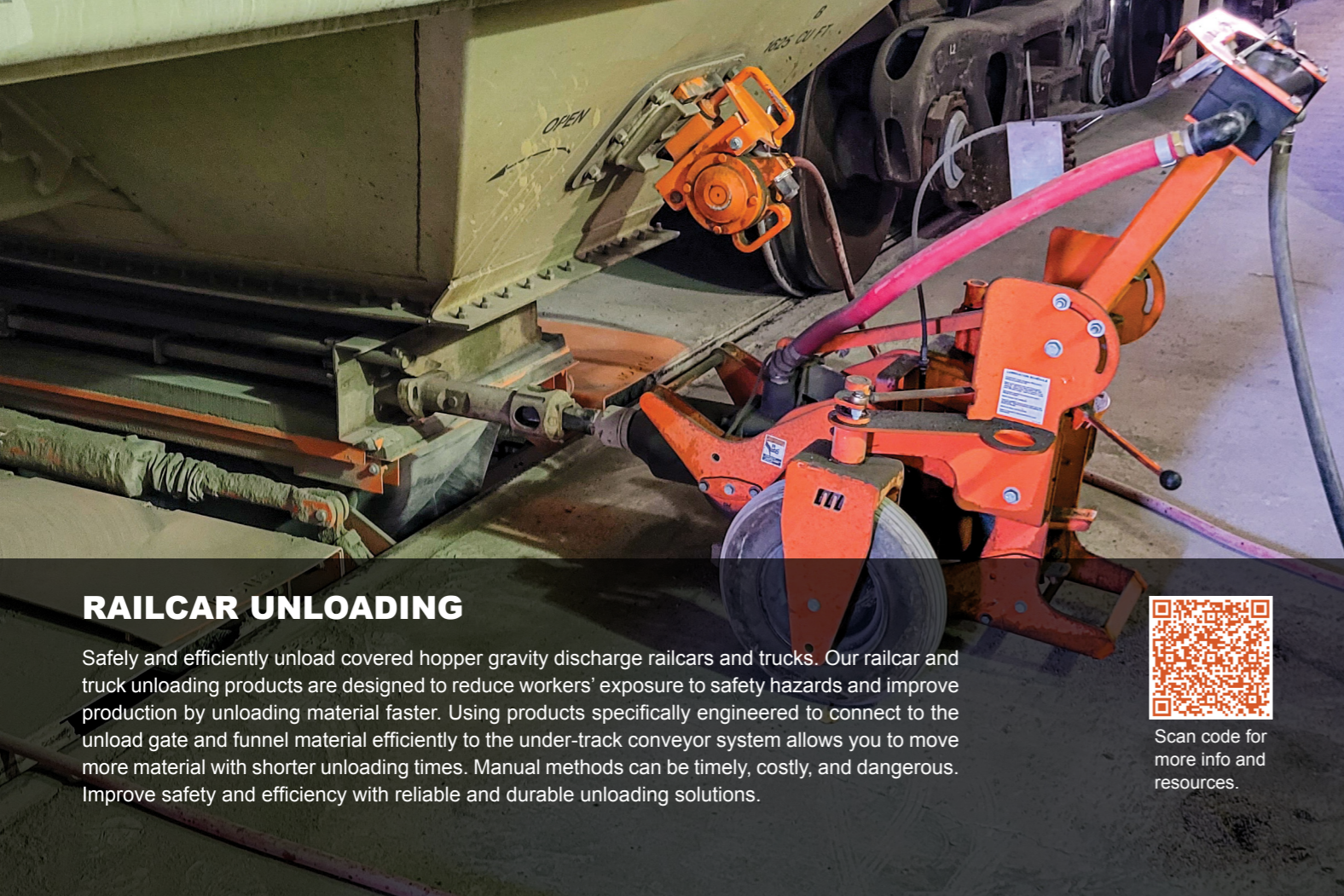

RAILCAR UNLOADING

Safely and efficiently unload covered hopper gravity discharge railcars and trucks. Our railcar and truck unloading products are designed to reduce workers' exposure to safety hazards and improve production by unloading material faster. Using products specifically engineered to connect to the unload gate and funnel material efficiently to the under-track conveyor system allows you to move more material with shorter unloading times. Manual methods can be timely, costly, and dangerous. Improve safety and efficiency with reliable and durable unloading solutions.



Scan code for more info and resources.

Boot-Lift® Railcar Connectors

Boot-Lift® Railcar Connectors improve the speed and safety of connecting a hopper car to under-track systems, without requiring workers to crawl under the car.

Boot-Lift® Railcar Connectors install directly onto the track flanges. Sponge seals fit securely to the hopper car unloading gates for a clean, reliable, and efficient transfer of material to the under-track conveying system, eliminating spillage and contamination.

Multiple opening configurations and seal materials are available to perfectly match your railcar unloading gates and cargo requirements.

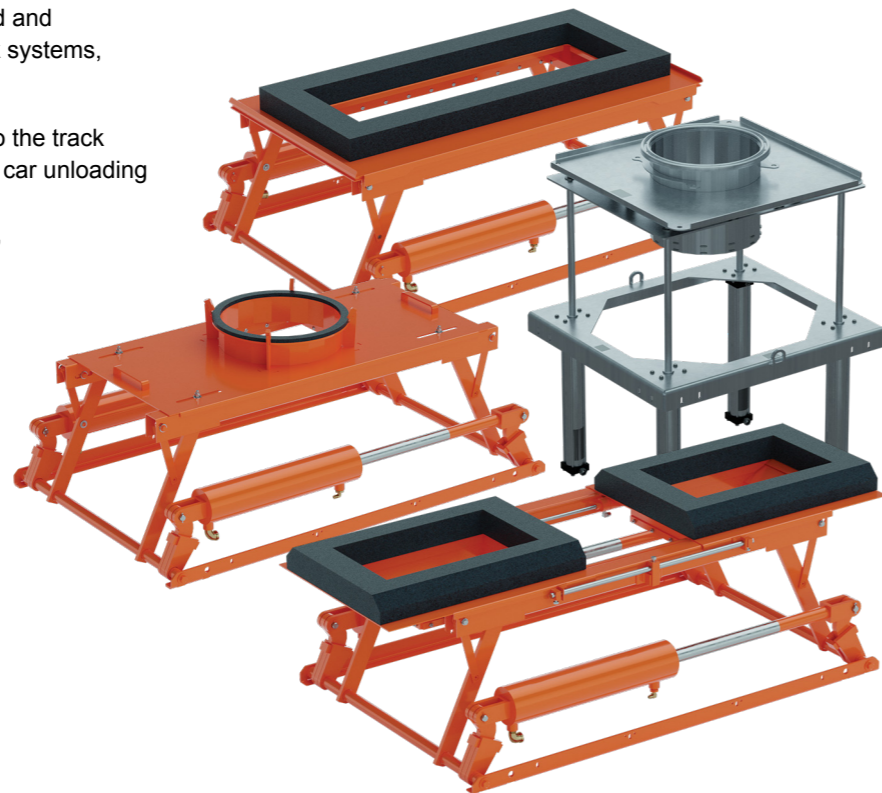

Railcar Opener

The Martin® Gen 4 Railcar Opener is an air-powered opener that maneuvers easily on two wheels to open hopper car gates and start efficient unloading.

Powers open the most stubborn hopper car gate with smooth, non-impacting force, delivering up to 3,750 ft-lb (5084 N-m) of torque at 100 psi (6.2 bar).

One lever rotates wheels 90 degrees, keeping the opener in contact with traveling capstan while the capstan drive height can be adjusted to fit various car gates and compensate for variations in unloading platforms. Ergonomic balanced wheeled cart can be positioned by one worker and the handle easily adjusts to suit operator preference. Equipped with "flat free" tires.



>> See the Railcar Opener in action.

Gen 4 conversion kit available for Gen 3 Railcar Openers.

Impacting Railcar Opener

The Martin® Impacting Railcar Opener is a high-speed/high-torque pneumatic opener that delivers up to 1382 kg-m (10,000 ft-lbs) of impacting torque at 90 psi to quickly and easily open and close hopper car gates, eliminating stalled operations, excess labor, and back injuries caused by stubborn gates.

One lever rotates wheels 90 degrees, keeping the opener in contact with traveling capstan while the capstan drive height can be adjusted to fit various car gates and compensate for variations in unloading platforms. Ergonomic balanced wheeled cart can be positioned by one worker and the handle easily adjusts to suit operator preference. Equipped with "flat free" tires.

Rugged steel tube frame construction provides long life in "real world" conditions. Impacting tool can be greased to extend the life of internal wear parts.



Visit our website to download our **Foundations™ Books**, industry-standard textbooks for cleaner, safer, and more productive conveyor operation and maintenance, along with e-books covering a variety of specific bulk material handling and material flow topics. >> foundations.martin-eng.com/book-options

Gate Jack Railcar Opener

Martin® Gate Jack Opener is a single-worker, portable, air-operated system that opens stubborn railcar gates quickly, without risking back injury or needing extra personnel. Capstan extension reaches even "hard-to-get-at" recessed railcar capstans.

Operates from an efficient air supply. Unit is readily portable for easy positioning and use by one worker and comes supplied with hoses and hand-held control valve. Customer must supply own steel "lever" bar.

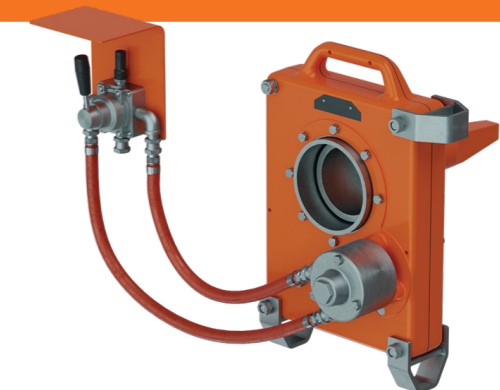

Vibrotor™ CCR Railcar Vibrator

This simple, long-lasting Vibrotor™ CCR Railcar Vibrator provides effective high-frequency vibration of both the hopper section and vertical wall at an economical price.

Bearing-free design eliminates wear problems and extends service life while the rugged wedge bracket is built for long life and durability.

Ergonomic handle makes placement and removal easier.



3-in. Impacting Railcar Vibrator

Compact vibrator and mount assembly provides up to 918 kg (2,024 lbs) of linear force to unload stubborn materials.

Vibrator and wedge system weighs only 22 kg (49 lb). Lightweight vibrator with handle makes mounting/ dismantling a “no-strain” procedure.

Air-efficient design operates on air supply from 40 to 80 psi (2.8 to 5.5 bar); consumes 30.5 cfm at 80 psi (425 L/min at 5.5 bar).



4-in. Impacting Railcar Vibrator

Compact vibrator and mount assembly provides up to 998 kg (2,200 lbs) of linear force to unload stubborn materials.

Unique handle provides operators several grip options.

Air-efficient design operates on air supply from 40 to 80 psi (2.8 to 5.5 bar); consumes 30.5 cfm at 80 psi (425 L/min at 5.5 bar).



Impacting Railcar Vibrator

Martin® Impacting Railcar Vibrator delivers a powerful force output of 1,542 kgs at 80 psi while only weighing 21 kgs, making it the highest-force, lowest-weight portable railcar vibrator available.

Easy-to-handle, lightweight vibrator and shoe make mounting/dismounting a “no-strain” procedure. Provides the necessary linear force required to activate the free flow of tough materials that are sticky, coarse, and high in moisture.



Non-Impacting Railcar Vibrator

This lightweight, low-noise system combines a non-impacting linear vibrator with a urethane mounting shoe to provide up to 454 kg (1000 lbs) of force. Non-impacting vibrator and urethane mounting shoe eliminate metal-to-metal noise, producing only 80-85 db.

Compact vibrator and mount assembly weighs only 15 kg (33 lb) while providing plenty of power to unload the most stubborn materials. Air-efficient design operates on air supply from 40 to 80 psi (2.8 to 5.5 bar) and consumes only 15 cfm at 80 psi (425 L/min at 5.5 bar).

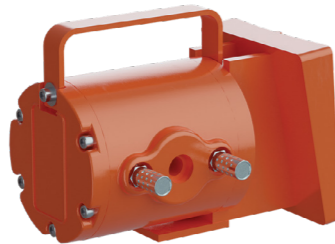

Vibrator Storage Stand & Cart

The Railcar Vibrator Stand and Cart is designed to reduce operator strain and streamline vibrator handling. This mobile stand keeps the vibrator elevated off the ground, eliminating the need for bending and minimising lifting and carrying during setup and storage.

With built-in wheels, it doubles as a cart—allowing operators to roll the vibrator into position, lift it a few inches, and place it into the railcar with ease. Once the job is done, the vibrator can be simply returned to the stand and rolled out of the way.



SERVICES AND TRAINING

At Martin Engineering, we offer a variety of services and training to enhance the efficiency, safety, and lifespan of your bulk material handling systems. From conveyor inspections and maintenance program like Walk the Belt™ to addressing issues such as dust control and belt tracking, our goal is to optimise your operations. We also provide comprehensive training—whether on-site or online—to equip your team with the knowledge they need for maintaining equipment and following best practices.

Walk The Belt™

This program offers free, customised conveyor system inspections to identify and address issues like carryback, mistracking, and dust. These inspections are conducted by highly-trained technicians, who then provide a detailed report with recommendations to improve performance and extend equipment life. This proactive maintenance approach reduces unscheduled downtime and enhances safety, allowing plant managers to focus on core operations.

Foundations™ Training

Martin Engineering's Foundations™ training program was conceived as a way to package our accumulated knowledge and deliver it in an impactful, engaging way. Classes are based on our two highly-regarded books, *Foundations™* and *Foundations™ for Conveyor Safety*. The program addresses many key topics to improve safety and productivity.



Visit Martin Engineering's official **YouTube channel** to view a selection of hundreds of long- and short-form videos offering a range of content from expert insights and webinar excerpts to product highlights and case studies, and much more.

>> youtube.com/@martinengineering

visit martin-eng.com.au



We freely share our 80+ years of global knowledge and experience with everyone to help make bulk materials handling cleaner, safer, and more productive.

Access our free resources at the following locations:



**Foundations™
Learning Centre**

>> foundations.martin-eng.com/en/knowledge



**Martin Engineering
E-Books**

>> foundations.martin-eng.com/book-options



**Martin Engineering
YouTube Channel**

>> youtube.com/@martinengineering



**Foundations™
On-Demand Webinars**

>> foundations.martin-eng.com/webinars-on-demand

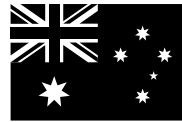

Questions? Contact our team at company headquarters in Stapylton, Queensland:



+ 61 1300 627 364



salesau@martin-eng.com



martin-eng.com.au

Stay up-to-date with our latest news, events, and resources by following us on social media.



Martin Engineering Australia | 102 Christensen Road South Stapylton QLD 4207

L4203-02/26

Patents and patents pending. ® Registered trademark of Martin Engineering Company in the US and other select locations. © 2026 Martin Engineering Company.