

MARTIN® HYDRAULIC VIBRATORS

Founded in 1944 on vibration technologies, Martin has a long history of producing high quality, innovative products that make bulk material handling cleaner, safer and more productive.

With the experience and expertise to produce and manufacture vibration products of the highest quality, all backed by our *Absolutely No Excuses Guarantee*, Martin is the clear choice in electric vibrators for all industrial and OEM vibration applications.

Martin offers a comprehensive and expansive selection of vibration products—all designed, engineered and manufactured in the USA and by other Martin companies worldwide.*

* Price and delivery subject to country of origin.

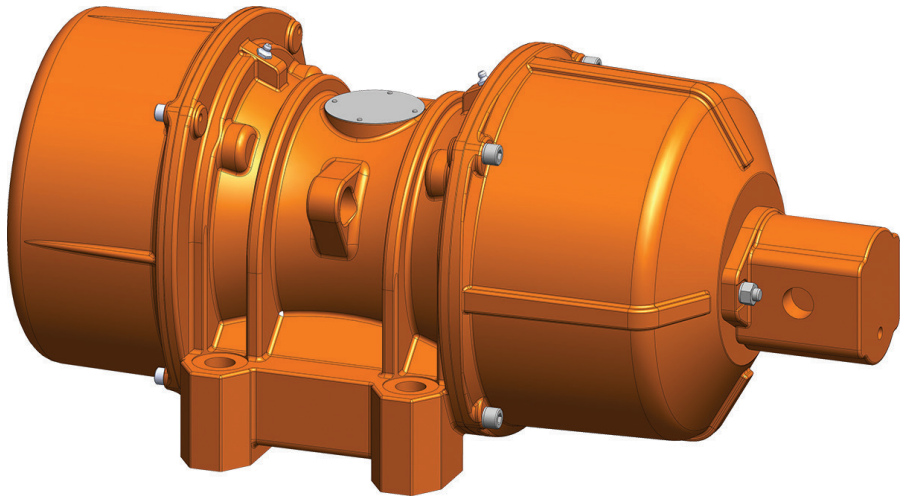

- Up to 8300 pounds of centrifugal force
- Bearing lubrication needed only every 2000 operating hours
- Quiet operation
- Works in portable screen applications where no electricity is available
- Same mounting bolt patterns as Martin® Electric Vibrators
- Worldwide tech support and service
- Unsurpassed 3-year warranty

MARTIN® HYDRAULIC VIBRATORS

Model	Weight Setting	Unbalance in-lb (kg-cm)	Centrifugal Force lbs (kg)	Weight lbs (kg)	RPM	GPM
HSV12-6050	100%	148 (170)	6050 (2744)	195 (88)	1200	5.0
HSV18-5900	100%	64 (73)	5900 (2676)	165 (75)	1800	7.5
HSV18-8300	100%	90 (103)	8300 (3765)	182 (83)	1800	7.5



Martin Engineering Australia Pty Ltd.
20 Ern Harley Dr - Burleigh Heads, QLD, 4220 - Australia
1300 627 364
www.martin-eng.com.au

